



WESTERN PRODUCTS  
P.O. BOX 245038  
MILWAUKEE, WISCONSIN 53224-9538

UniMount™

dd A DIVISION OF DOUGLAS DYNAMICS, INC.

Vehicle Installation Instructions and  
Parts List

Model 1525  
Mount Assembly Box No. 61975  
Chevrolet /GMC 2WD  
C & R 20/2500 - 30/3500 1981 - 1991  
Headlamp Kit No. 61540  
Hydraulics Box No. 56365  
Harness Kit No. 61545 or 61565  
October 31, 2003

Mount Assembly Box No. 61975  
PARTS DIAGRAM & LIST

MINIMUM VEHICLE RECOMMENDATIONS
HD Alternator HD Battery FRT Aux Air Bag Springs - (GAWR less than 4,000 lbs.)
<b>REAR BALLAST -</b> 500 lbs. when plow is attached. <b>SECURE WEIGHT BEHIND REAR WHEELS.</b>

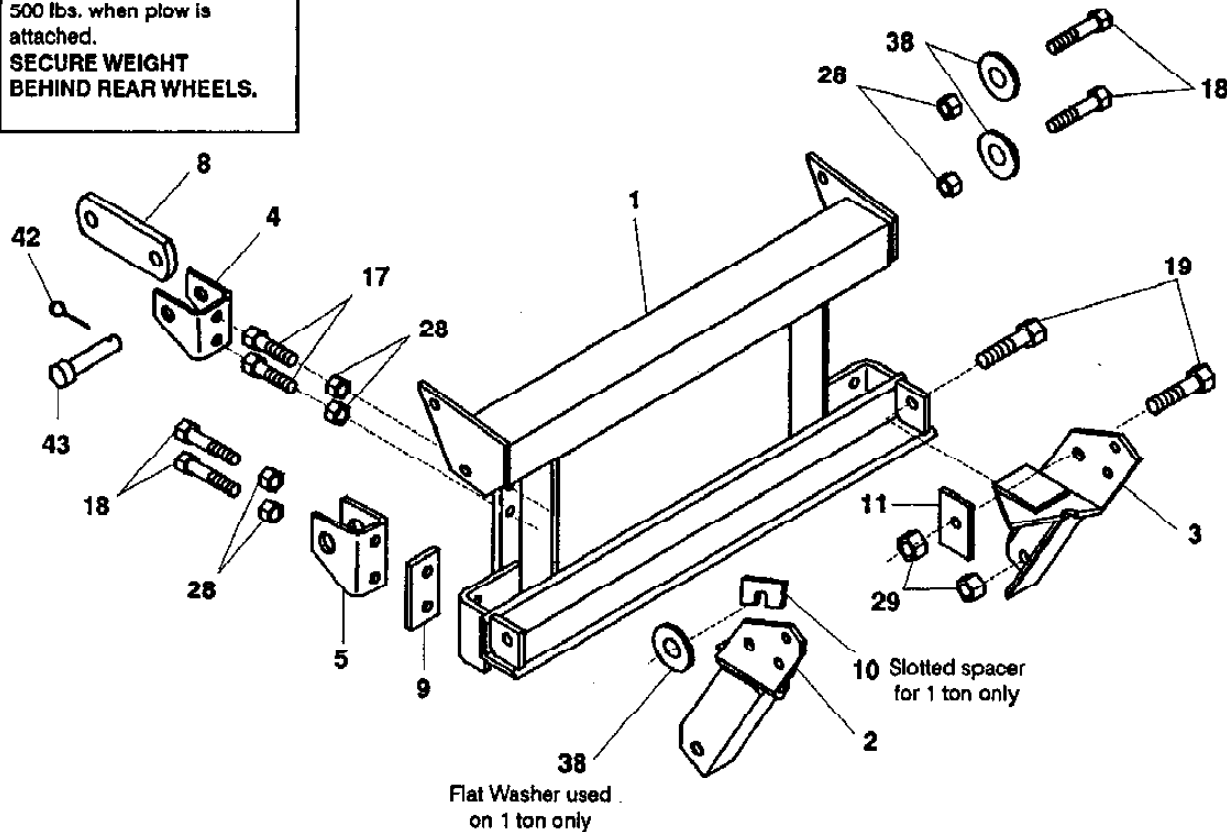

ITEM	PART NO.	QTY	DESCRIPTION
1	61955	1	MOUNT FRAME 1525
2	61959	1	THRUST ARM DR
3	61960	1	THRUST ARM CU
4	61916	2	LINK ARM LUG
5	61917	2	COUPLING LUG
8	61412	2	LINK ARM
9	61970	2	LUG SPACER
10	61974	2	SLOTTED SPACER
11	61967	2	RETAINER
17	90100	4	1/2-13X1-1/2 HX CS G5 ZP
18	90101	8	1/2-13X1-3/4 HX CS G5 ZP
19	90128	4	5/8-11X1-3/4 HX CS G5 ZP
28	91335	12	1/2-13 PT HX LK NUT NYIS ZP
29	91337	4	5/8-11 PT HX LK NUT NYIS ZP
38	91105	6	1/2 PLAIN WASHER TY A STD ZP
42	91911	2	5/32X1-1/2 COTTER PIN ZP
43	93062	2	RIVET 3/4" X 3-1/4" G5 ZP

ITEM	PART NO.	QTY	DESCRIPTION
<b>NOT SHOWN</b>			
	22381	1	BATTERY ADAPTERS, SIDE TERMINAL
	61536	2	CABLE TIE - LONG
	56080	1	DASH BRACKET

Parts listed above may be found in the following assembly

61976	1	BOLT BAG ASSY (61975)
-------	---	-----------------------

Abbreviations	
CS	Capscrew
CU	Curb-Side
DR	Driver-Side
G	Grade
HX	Hex
LK	Lock
NYIS	Nylon Insert
PT	Prevailing Torque
STD	Standard
TY	Type
ZP	Zinc Plate

**AS VIEWED FROM DRIVER SIDE**

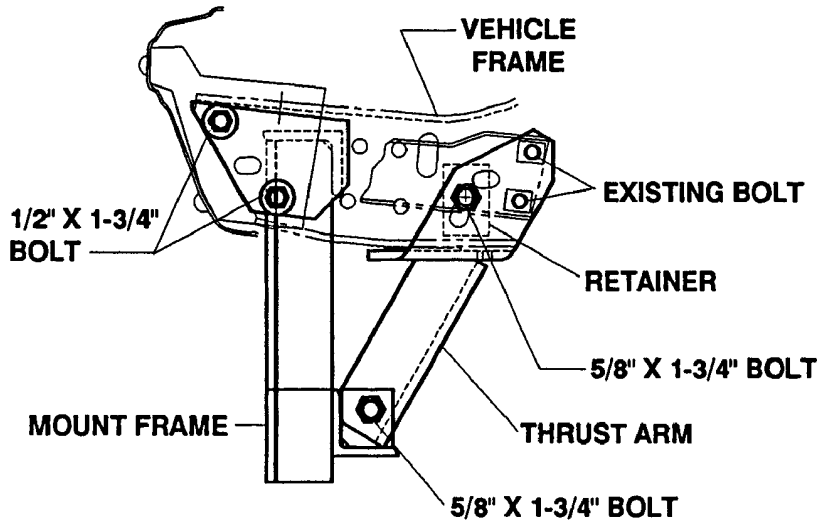

Recommended Fastener Torque Chart (Ft.-Lbs.)			
Size	SAE	SAE	SAE
	Grade 2	Grade 5	Grade 8
1/4-20	6	9	13
5/16-18	11	18	28
3/8-16	19	31	46
3/8-24	24	46	68
7/16-14	30	50	75
1/2-13	45	75	115
9/16-12	68	110	165
5/8-11	93	150	225
3/4-10	150	250	370
7/8-9	202	378	591
1-8	300	583	589

Metric Grade 8.8 (Ft.-Lbs.)			
Size	Torque	Size	Torque
M 6	7	M 12	60
M 8	17	M 14	95
M 10	35	M 16	155

These torque values apply to mount assembly fasteners except those noted in the instruction.

**IMPORTANT:** Read instructions before assembling. Bolts should be finger tight until instructed to tighten to torque shown in torque chart. Use standard methods and practices when attaching snowplow including wearing safety glasses during drilling.

**SNOWPLOW MOUNT ASSEMBLY:**

**NOTE:** Some models have an air dam mounted below the front bumper that interferes with the snowplow mount installation and must be removed. The air dam should be retained and reinstalled whenever the snowplow mount is removed from the vehicle.

Disconnect park/turn lamps from bumper. Remove bumper from vehicle and bumper brackets from frame horn. Remove diagonal bumper braces. Loosely reinstall bumper brackets to bumper.

**NOTE: 1 TON TRUCKS -** The diagonal frame brace bars must be loosened and shifted out of the way to remove the diagonal bumper brace bolts.

**THRUST ARMS**

1. Position each thrust arm tight against outside and bottom of vehicle frame aligning holes in thrust arms with slots and diagonal bumper brace holes in vehicle frame.
2. Insert a 5/8" x 1-3/4" bolt in forward hole of thrust arm and retain with retainer and locknut inside vehicle frame. (NOTE - Retainer hole is offset to allow best placement of retainer bar to hold thrust arm up tight to bottom of frame.)

On 1 TON TRUCKS, trim retainer bars as required for clearance to diagonal frame brace bars.

3. Reattach diagonal bumper braces with existing fasteners through the two rear holes of thrust arms.

**MOUNT FRAME**

1. Slide mount into frame horns, aligning holes to bumper bracket mounting holes, and attach thrust arms to inside of mount tabs with a 5/8" x 1-3/4" bolt and locknut on each side.
2. Install bumper, with brackets to outside of frame horns, using two 1/2" x 1-3/4" bolts, flat washers and locknuts on each side of vehicle. Install flat washers against bumper bracket slots.
3. Reattach diagonal bumper braces to bumper with existing fasteners.
4. Starting with the thrust arm to frame 5/8" bolts:

**TIGHTEN ALL FASTENERS TO CORRESPONDING TORQUE CHART VALUES.**

On 1 TON TRUCKS, reattach the diagonal frame brace bars with existing fasteners, placing the slotted spacer and 1/2" flat washer under fastener on outside of vehicle frame.

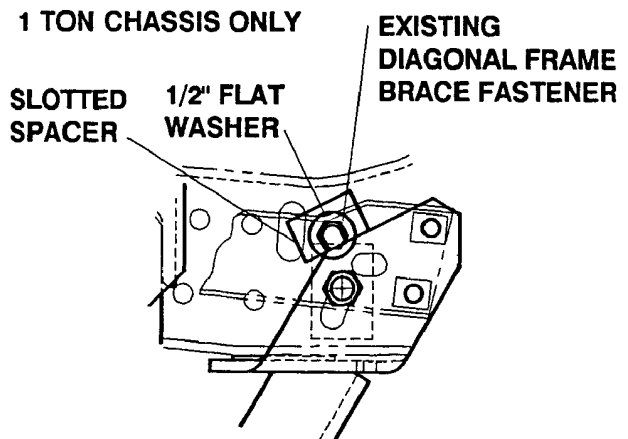

## COUPLING LUGS

1. During coupling lug installation, allow for drop in vehicle height when weight of plow is added. Final coupling lug hole center to level surface distance should be 9-1/2" to 10-1/2" with plow attached and resting on the level surface. (Turning coupling lugs upside down changes height by 1")

Position a coupling lug (1" diameter holes) with a lug spacer against each lower pair of holes in mount frame.

2. Secure with two 1/2" x 1-3/4 bolts and locknuts for each coupling lug.

## LINK ARM LUGS

1. Install link arm lugs (3/4" diameter holes) so angled side is in the same position as the angled side of the coupling lugs. Position the link arm lugs to the upper pairs of holes on the mount angle.

NOTE: Centers of coupling lug holes to centers of link arm lug holes should be 5-1/2".

2. Secure each link arm lug with two 1/2" x 1-1/2" bolts and locknuts.

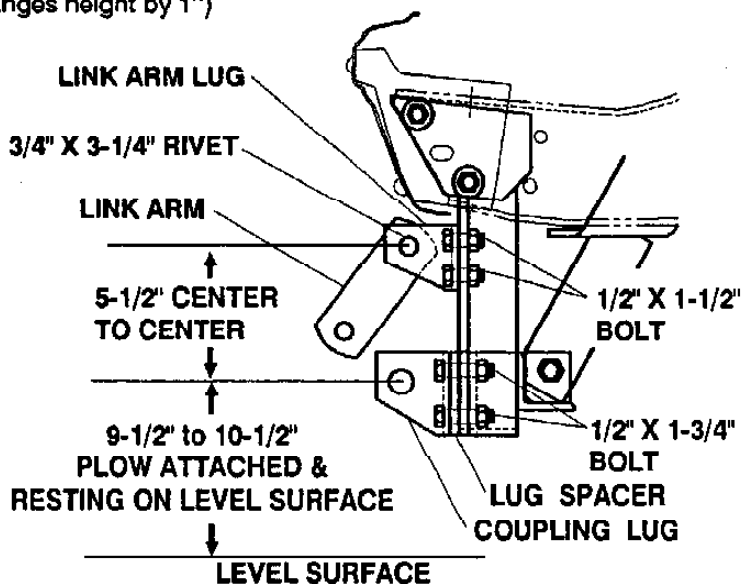

**TIGHTEN ALL FASTENERS TO CORRESPONDING TORQUE CHART VALUES.**

## LINK ARMS

Fasten one link arm between the legs of each link arm lug with a 3/4" x 3-1/4" grade 5 rivet and cotter pin.

**NOTE:** After 5 to 10 hours of snowplow usage, retorque all mount assembly fasteners.

**NOTE:** During electrical installation, THE LONG BATTERY GROUND CABLE (no stripe) MUST BE GROUNDED TO THE NEGATIVE BATTERY TERMINAL.

## HARNESS KIT SELECTION

For DUAL Type 2B/2D headlamps, use Box No. 61540 Headlamp Kit 9-Pin and 61545 Harness Kit 2B/2D 9-Pin-A.  
For QUAD Type 1A & 2A headlamps, use Box No. 61540 Headlamp Kit 9-Pin and 61565 Harness Kit 1A & 2A 9-Pin-A.

## Solenoid Control and Dash Bracket INSTALLATION INSTRUCTIONS

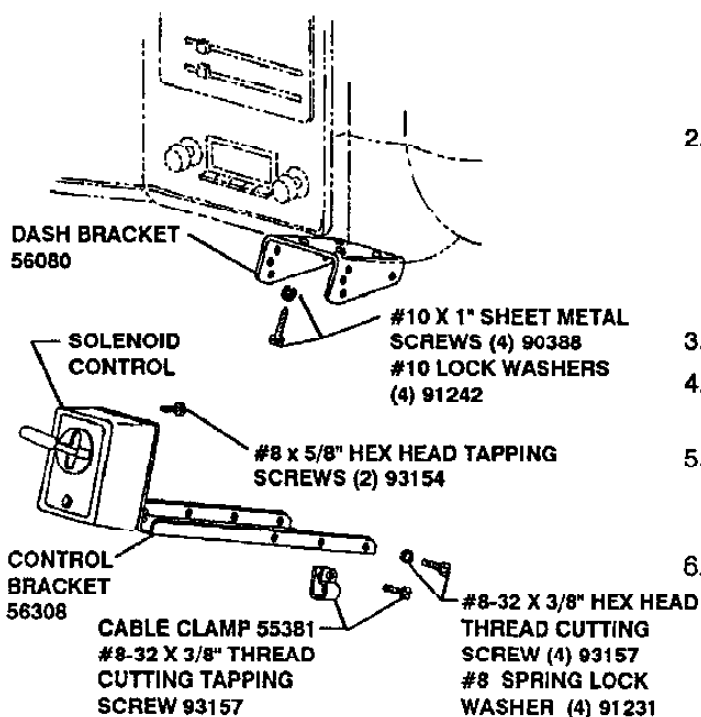

1. Secure solenoid control to control bracket using two #8 x 5/8" hex head tapping screws, and control bracket to dash bracket using four #8 x 3/8" hex head thread cutting screws. Secure control cable to control bracket with cable clamp using one #8 x 3/8" hex head thread cutting screw.
  2. Locate assembly to the dash as shown, below and to the right of the radio, or wherever is most convenient. The dash bracket should fit fairly flat against the bottom surface of the dash. Verify that control will clear vehicle components in all positions. Check for clearance before drilling holes.
  3. Mark this location.
  4. Remove the dash bracket. Place dash bracket in selected location and mark four holes.
  5. Drill 1/8" holes in marked locations. Secure dash bracket using four #10 x 1" sheet metal screws and lock washers.
  6. Place control into dash bracket and fasten in desired position reusing fasteners from paragraph 1 above.
- NOTE:** Bend top flange of control bracket to desired position.

**9-Pin Vehicle Harness And Motor Relay**

Except as noted, parts to be installed are found in the hydraulics box.

**NOTE:** To prevent corrosion on all underhood electrical connections, use dielectric grease to fill receptacles and lightly coat ring terminals and blades before assembly or lightly coat connections after assembly.

**HARNESS, SOLENOID CONTROL  
& MOTOR RELAY  
INSTALLATION**

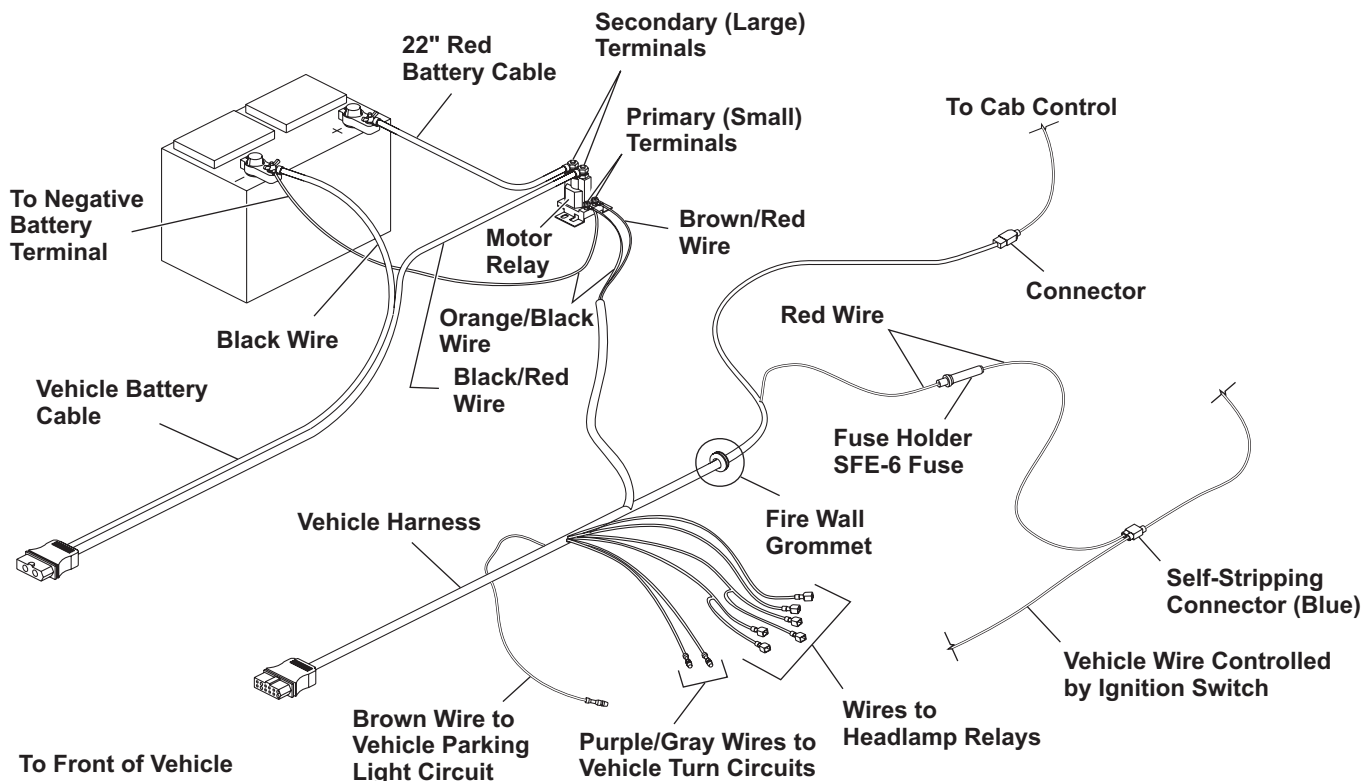

1. Identify wires for the parking lamp on the driver-side and the turn signals on both sides. Attach a black self-striping bullet receptacle connector (found in harness kit) to each of these three wires.
2. Remove negative battery cable from battery.

**WARNING: Electrical shock hazard. Disconnect battery before beginning electrical installation.**

3. Find a location for the motor relay where it will be protected from road splash and will be within 18" of the vehicle primary battery. Note: Motor relay terminals must be up or horizontal. Using the motor relay mounting plate as a template, drill two 9/32" holes, and mount motor relay to holes using 1/4" x 3/4" bolts, flat washers, and locknuts.
4. Route 22" red battery cable between a large motor relay terminal and the POSITIVE (+) battery terminal, taking care to avoid sharp edges and hot or moving parts. Attach cable to motor relay terminal with a lock washer and 5/16"-24 jam nut. Attach cable to the battery POSITIVE (+) terminal with the furnished battery adapter. (Adapters found in mount box.) Tighten battery adapter to 124–178 in-lb. Attach OEM battery cable to adapter with original bolt. Hold adapter while tightening original bolt to 124–178 in-lb.

5. Stretch rectangular openings of plug cover straps (found in harness kit) over grill connector ends of long battery cable assembly (found in hydraulics box) and 9 pin vehicle harness (found in harness kit). Place plug covers over molds on harnesses.

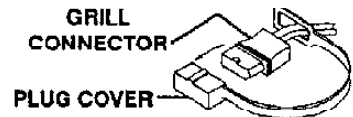

6. Find a location in the vehicle grill on the battery side for mounting the battery cable grill connector. The best location is at least 10-1/2" from the center of the grill and at a convenient height for connecting the plow plugs.

**Grill openings less than 3/4" high:**

Allow grill connector of each harness to hang out in front of grill. Allow enough cable so it is easy to mate and remove connectors.

**Grill openings more than 3/4" high:**

Use panel mount plates (found in mount box) to mount grill connectors to grill. For openings 3/4" to 1-1/4" mount the plates in front of the grill. For openings larger than 1-1/4", mount plates behind the grill (this will conceal the connector when not in use), making sure connectors can be easily mated.

If using mount plates, slide grooves of grill connectors into the large rectangular openings of the panel mount plates. Route the plug cover strap through the opening of the panel mount plates.

7. Route battery cable through the grill at the selected location and through or around the radiator bulkhead to motor relay taking care to avoid sharp edges and hot or moving parts.  
If using mounting plate, make sure the center key is up and secure the mount plate to the grill using four long cable ties (found in harness kit). Hide cable latch behind grill.
8. Attach cable with red stripe to the unused large terminal on the motor relay, and secure it with a lock washer and 5/16"-24 jam nut.
9. Route cable without stripe directly to the negative battery terminal (separate the two cables as needed to reach the battery DO NOT attach cable to battery at this time).
10. Find a location in grill on driver-side for mounting 9 pin vehicle harness (similar position to battery cable mount). See Step #6 & 7 above for how to mount. Route 9 pin vehicle harness through grill and around or through radiator bulkhead (drill 5/8" hole if needed) into engine compartment.
11. Route the wires that break out of the 9 pin vehicle harness to the area behind the driver-side headlamp. Route rest of harness to the firewall. Drill a 5/8" hole through the firewall in any convenient location away from hot or moving engine parts. Feed fuse holder through hole first and then feed the plastic connector and harness through to the cab.
12. Route brown/red and black/orange wire loom to motor relay. Attach each ring terminal to a separate small terminal on motor relay using a lock washer and #10-32 nut for each terminal.
13. Attach the hydraulic unit black battery cable and orange/black wire terminal to the negative terminal with the furnished battery cable adapter. (Adapters found in mount box.) Tighten battery adapter to 124–178 in-lb. Attach OEM battery cable to adapter with original bolt. Hold adapter while tightening original bolt to 124–178 in-lb.
14. **Inside the cab, route 9 pin vehicle harness connector to solenoid control and couple the connectors together.**
15. Locate an accessory wire or unused fuse box terminal capable of carrying 7 amps and controlled by the ignition (key) switch. Route the vehicle harness SFE-6 fuse holder red wire to this location and trim off any excess length of wire (keep fuse holder in system).

**Fuse block terminal as source:** Attach a terminal (not furnished) to the vehicle harness red wire and plug on to fuse box terminal. If DRL wire is used, crimp pink wire into the same terminal with the red wire.

**Accessory wire as source:** Open blue self-stripping connector and place the end of the red wire against the inner groove stop (end of wire must not extend from the connector) and the accessory wire in the outer groove. Close connector over the wires using a pair of pliers and snap the locking tab in place. Repeat with DRL pink wire.

Continued on next page.

# PLUG-IN HARNESS & HEADLAMP RELAY INSTALLATION

## PLUG-IN HARNESS INSTALLATION DIAGRAM

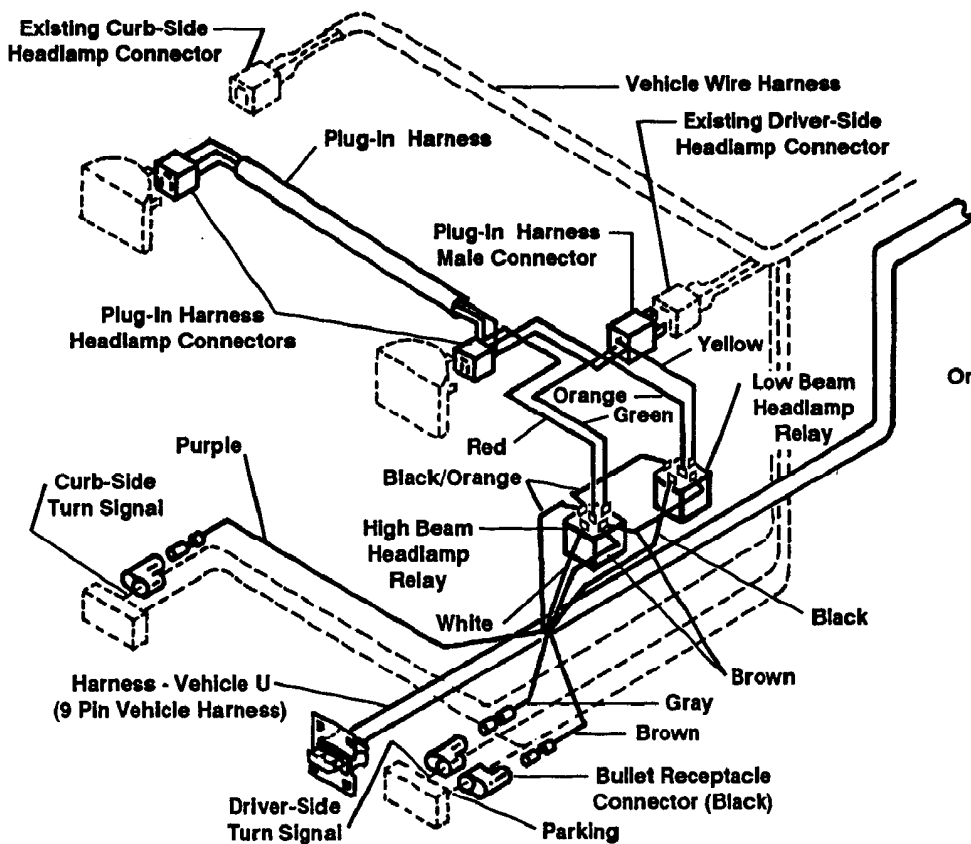

## HEADLAMP RELAY WIRING DIAGRAM Type - A

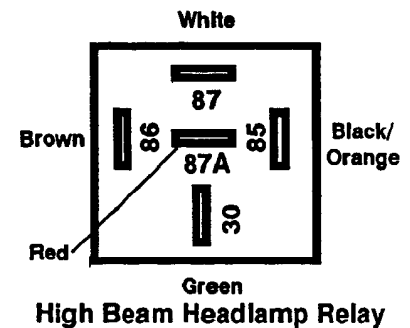
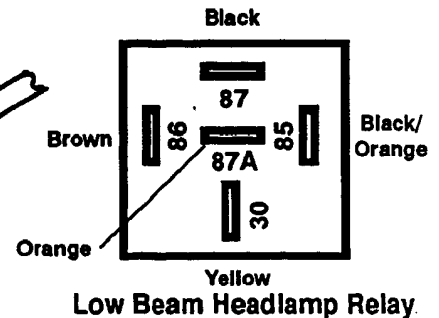

### Plug-in Harness & Headlamp Relay

- In the engine compartment behind the driver-side headlamp, insert wire bullets from 9 pin vehicle harness into black bullet connectors (installed in step #1 of previous section) as follows:  
Brown wire to parking lamp wire on driver-side.  
Gray wire to turn signal wire on driver-side.
- At the vehicle driver-side headlamp, remove the connector(s) from the headlamp(s) and couple matching connector with plug-in harness 3-wire male plug (found in harness kit). Attach plug-in harness headlamp connector(s) to headlamp terminals.
- Route other end of plug-in harness along radiator bulkhead or over radiator shroud to curb-side headlamp(s). Remove headlamp connector(s) and secure connector(s) with a cable tie (found in harness kit). Attach plug-in harness headlamp connector(s) to headlamp terminals.
- On the curb-side, insert purple wire bullet from plug-in harness into vehicle turn signal black bullet connector installed in step # 1 of the previous section.
- At the driver-side headlamp(s), insert the purple wire bullet from the vehicle harness into the purple wire receptacle on the plug-in harness.
- At driver-side headlamp, connect 9 pin vehicle and plug-in harness wires with receptacle to the two headlamp relays (found in harness kit) as shown in the above diagram. Use cable ties (found in harness kit) to secure relays and prevent accidental grounding of connections.
- Place grommet around 9 pin vehicle harness and insert into firewall hole (also put a grommet in the hole in the radiator bulkhead if one was drilled). Use cable ties to secure harnesses and wires away from hot or moving engine parts.
- Unless noted in Harness Kit Selection paragraph on page 3 of these instructions, replace vehicle turn signal flasher with the flasher furnished in the harness kit.
- Lubricate terminal cavities of both grill connectors with dielectric grease. Furnish dielectric grease tube to vehicle owner for future lubrication of grill connectors.

**OPERATIONAL TESTS AND ADJUSTMENTS**

Mount plow assembly to vehicle. (See label on back of blade or owner's manual for mounting instructions.)

**Filling Hydraulic Unit**

1. Push lift channel all the way down.
2. Remove fill plug and fluid level plug.
3. Fill unit with automatic transmission fluid (ATF) through fill plug hole until fluid runs out of fluid level hole. Replace both plugs. **NOTE:** For low temperature operation you can use Mobil One or Texaco 1537 Aircraft Hydraulic Oil.

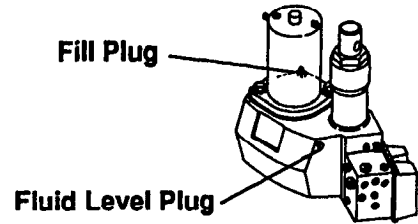

**Alternate method: (Systems without fluid level plug.)** Remove plow from vehicle. With stand lock pin in place, refill unit through fill plug opening. Unit is full when fluid reaches fill hole threads. Replace fill plug.

4. Turn ignition (key) switch to ON or ACCESSORY position.
5. Turn the control ON/OFF switch ON.
6. Move control lever to angle left and angle right several times to remove air from Hydra-Turn® rams. **DO NOT raise blade as this may cause pump cavitation.**
7. Refill unit with fluid following procedure in paragraph 3 of this section.
8. Move the control lever as indicated on label to control the plow. Raise and lower plow several times to remove air. Recheck fluid level per paragraph 3 of this section.

Capacity: Solenoid ISARMATIC® Mark IIIa reservoir      1-3/4 quarts  
 Equipped with 10" Hydra-Turn® rams                      2-3/8 quarts

**WARNING:** Always return lever to the neutral position. To prevent accidental movement of plow, always turn the solenoid control to OFF when the mounted plow is not in use.

**Blade Drop Speed Adjustment**

The quill on the top rear of the valve manifold (see diagram) adjusts blade drop speed.

- Turn quill IN (clockwise) to slow drop speed.
- Turn quill OUT (counterclockwise) to increase drop speed.

**NOTE:** Turning quill too far IN can slow raise time.

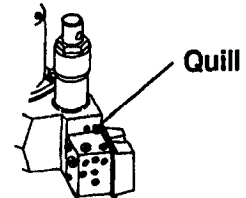

**COUPLING LUG HEIGHT CHECK**

**Coupling Lug Height Check:**

1. Mount plow to vehicle (see label on back of blade or owner's manual for mounting instructions).
2. Lift plow and move vehicle. Travel a minimum of 10 feet. Lower blade.
3. After step 2, with: blade on level surface, slack in lift chain, rear ballast located behind rear wheels,

center of coupling lug holes (hitch pin shaft) to level surface should measure 9-1/2" to 10-1/2". To obtain height,

1. Both coupling lugs and link arm lugs may be turned over to change height 1".
2. Install front Auxillary Air Bag Springs.

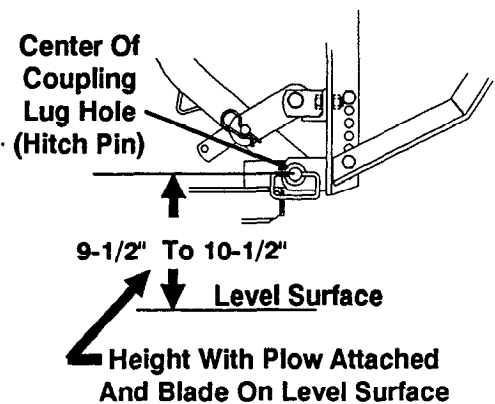

**NOTE:** Coupling height must be 9-1/2" minimum to allow stand to be pinned to lift frame.

4. Adjust chain slack with plow mounted to vehicle and lift channel pushed all the way down. To adjust, remove chain from hook. Straighten chain and pull tight. Rehook it to lift channel. After it is hooked, it will have the correct amount of slack for blade "float". **DO NOT** remove chain from lift channel when removing plow from vehicle.

Continued on next page.

**Final Hydraulic Inspection**

1. Make sure all fasteners and hydraulic and electrical connections are tight.
2. Check ram packing nuts for oil leakage. If any leakage is observed, tighten the packing nut 1/4 turn after you feel the nut contact the packing. Do not overtighten – overtightening affects cylinder operation and shortens the life of the packing. A short period of normal operation will allow chevron packings to become saturated, and leakage will normally stop.

---

**VEHICLE LIGHTING CHECK**

---

**Vehicle Lighting Check**

1. Check the operation of vehicle and plow lights.

Turn signals and parking lamps:

Parking lamps ON	Both vehicle and plow lamps should be on at the same time.
Right Turn Signal ON	Both vehicle and plow lamps should flash at the same time.
Left Turn Signal ON	Both vehicle and plow lamps should flash at the same time.

Headlamps:

Move vehicle headlamp switch to the ON position. Connecting and disconnecting the 9 or 12 pin plow plug from the grill connector should switch between vehicle and plow headlamps as follows:

9 or 12 pin plow plug DISCONNECTED	Vehicle headlamps should be on
9 or 12 pin plow plug CONNECTED	Plow headlamps should be on

Dimmer switch should dim whichever headlamps are operating. Likewise, the high beam indicator on the dash should light when either set of headlamps is on high beam.

Solenoid Control

The control indicator light should light whenever the control ON/OFF switch and the ignition (key) switches are both turned ON and the plow plugs are connected to the grill connectors.

The indicator light will also light when the control and ignition (key) switches are on and the plow plugs are disconnected. If the parking lights are turned on (with plow plugs disconnected), the indicator light will go out.

2. Connect plow plug to grill connector. Raise plow and aim plow headlamps according to SAE J599 Lighting Inspection Code (See Service Bulletin SP 608) and any applicable federal, state, or local regulations.
3. Check aim of vehicle headlamps with plow removed.
4. When plow is removed from the vehicle, install plug covers on grill connectors and insert the plow plugs into the boot on the hydraulic unit.

**NOTE:** After 5 to 10 hours of snowplow usage, retorque all mount assembly fasteners.

Mount Assembly Box No. 61975  
 Harness Kit Box No. 61545 or 61565  
 Hydraulics Box No. 56365

**PARTS DIAGRAM & LIST**

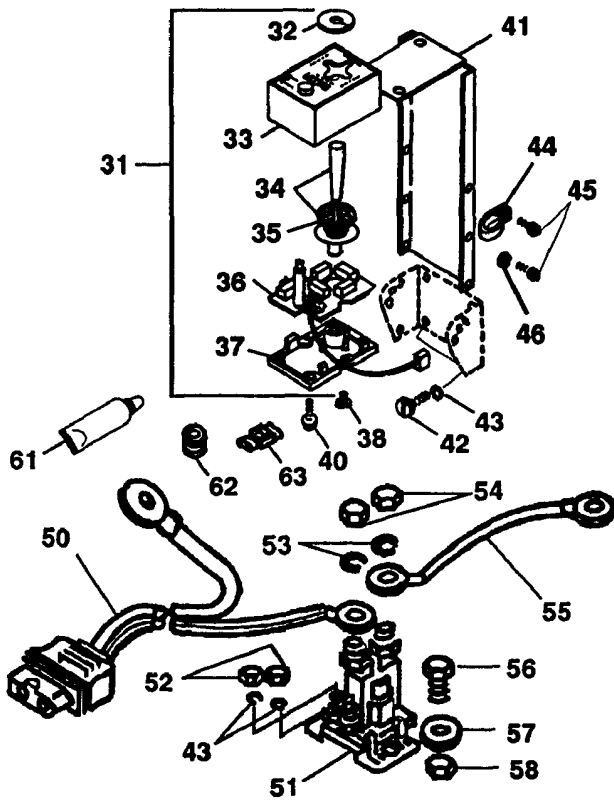

**ITEM PART NO. QTY. DESCRIPTION**

Found in Hydraulics Box No. 56365

31	56369	1	SOLENOID CONTROL (Style 2)
32	56283	1	SHIELD
33	49286	1	BODY W/LABEL & LENS (Style 2)
34	49287	1	LEVER, SPRING & ACTUATOR KIT (Style 2)
35	55923	1	SPRING - CONICAL
36	49283	1	PC BOARD ASSY MOLEX (Style 2)
37	56199	1	BASE
38	93153	2	#6-19X3/8 SL HXW TFTS HILO
40	93154	2	#8-18X5/8 SL HXW TFTS HILO
41	56308	1	CONTROL BRACKET
42	90388	4	#10X1 SL PN TFTS TY AB BZP
43	91242	4	#10 SP LK WASHER BPO
44	55381	1	CABLE CLAMP
45	93157	5	#8-32X3/8 SL HXW TCTS TY T BP
46	91231	4	#8 SP LK WASHER BP
50	61169	1	CABLE ASSEMBLY - VEHICLE
51	56134K	1	RELAY - SOLENOID HYDRAULIC SYS
43	91242	2	#10 SP LK WASHER BPO
52	91402	2	#10-32 HX NUT ZP
53	91202	2	5/16 SP LK WASHER ZP
54	92842	2	5/16-24 HX JAM NUT
55	22511	1	BATTERY CABLE 22" RED
56	90002	2	1/4-20X3/4 HX CS G2 ZP
57	91101	2	1/4 PLAIN WASHER TY A STD ZP
58	91331	2	1/4-20 PT HX LK NUT NYIS ZP
61	56099	1	DIELECTRIC GREASE TUBE
62	66130	2	RUBBER GROMMET
63	59114	1	SELF STRIP WIRE CONNECTOR

Parts listed above may be found in one of these assemblies.

56368	1	CARTON ASSY LOOSE PARTS U
56367	1	BOLT BAG ASSY LARGE U
56358	1	BOLT BAG SMALL U

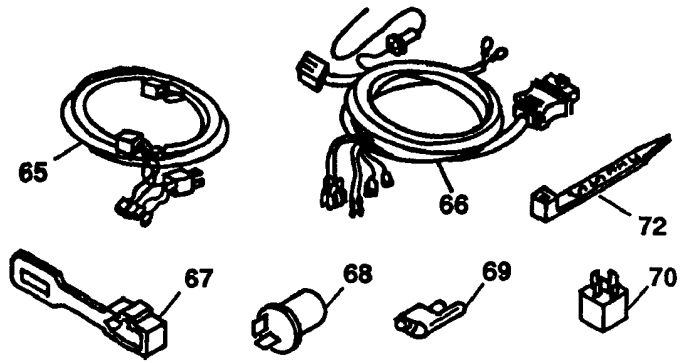

**ITEM PART NO. QTY. DESCRIPTION**

Found in Harness Kit Box No. 61545 OR 61565

65	61546	1	PLUG-IN HARNESS 2B/2D U -A (For Harness Kit No. 61545)
	61566	1	PLUG-IN HARNESS 1A & 2A U -A (For Harness Kit No 61565)
66	61437	1	VEHICLE HARNESS 9-PIN U
67	61548	2	PLUG COVER U
68	60109	1	FLASHER HD
69	59224	3	BULLET RECEPTACLE CONNECTOR
70	61535	2	HEADLAMP RELAY SPDT
72	59223	8	CABLE TIE

Parts listed above may be found in the following assembly.

61547	1	PARTS BAG
-------	---	-----------



**ITEM PART NO. QTY. DESCRIPTION**

Found in Mount Box No. 61975

85	61536	2	CABLE TIE - LONG
90	56080	1	DASH BRACKET

Parts listed above may be found in the following assembly.

61976	1	BOLT BAG ASSEMBLY
-------	---	-------------------

Abbreviations			
ASSY	Assembly	SL	Slotted
BP	Black Phosphate	SP	Spring
BPO	Black Phosphate & Oil	SPDT	Single Pole Double Throw
BZP	Black Zinc Plate	STD	Standard
CS	Capscrew	SYS	System
G	Grade	TCTS	Thread Cutting Tapping
HD	Heavy Duty		Screw
HX	Hex	TFTS	Thread Forming Tapping
HXW	Hex Washer		Screw
LK	Lock	TY	Type
NYIS	Nylon Insert	U	UniMount® System
PC	Printed Circuit	W/	With
PN	Pan	ZP	Zinc Plate
PT	Prevailing Torque		

Indented part numbers are included in the assembly under which they are listed. Quantities shown are included with the assembly.

## Wiring Diagram Harness Type - A

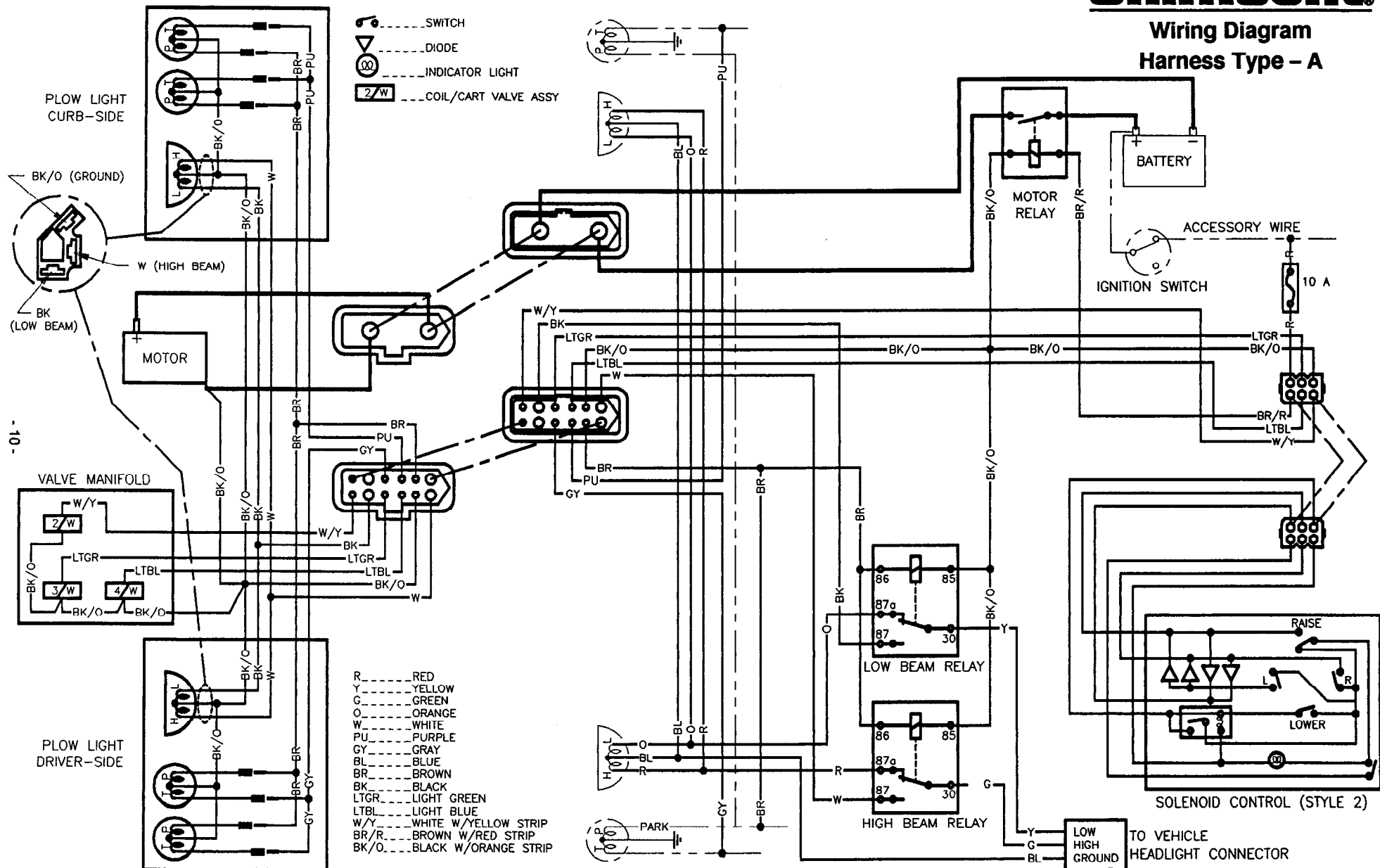

- 10 -

**Solenoid Control** – The control indicator light should light whenever the control ON/OFF switch and the ignition (key) switch are both turned ON and the plow plugs are connected to the grill connector.

The indicator light will also be on when the control and ignition (key) switches are ON and the plow plugs are disconnected. If the parking lights are turned on (with plow plugs disconnected), the indicator light will go out.

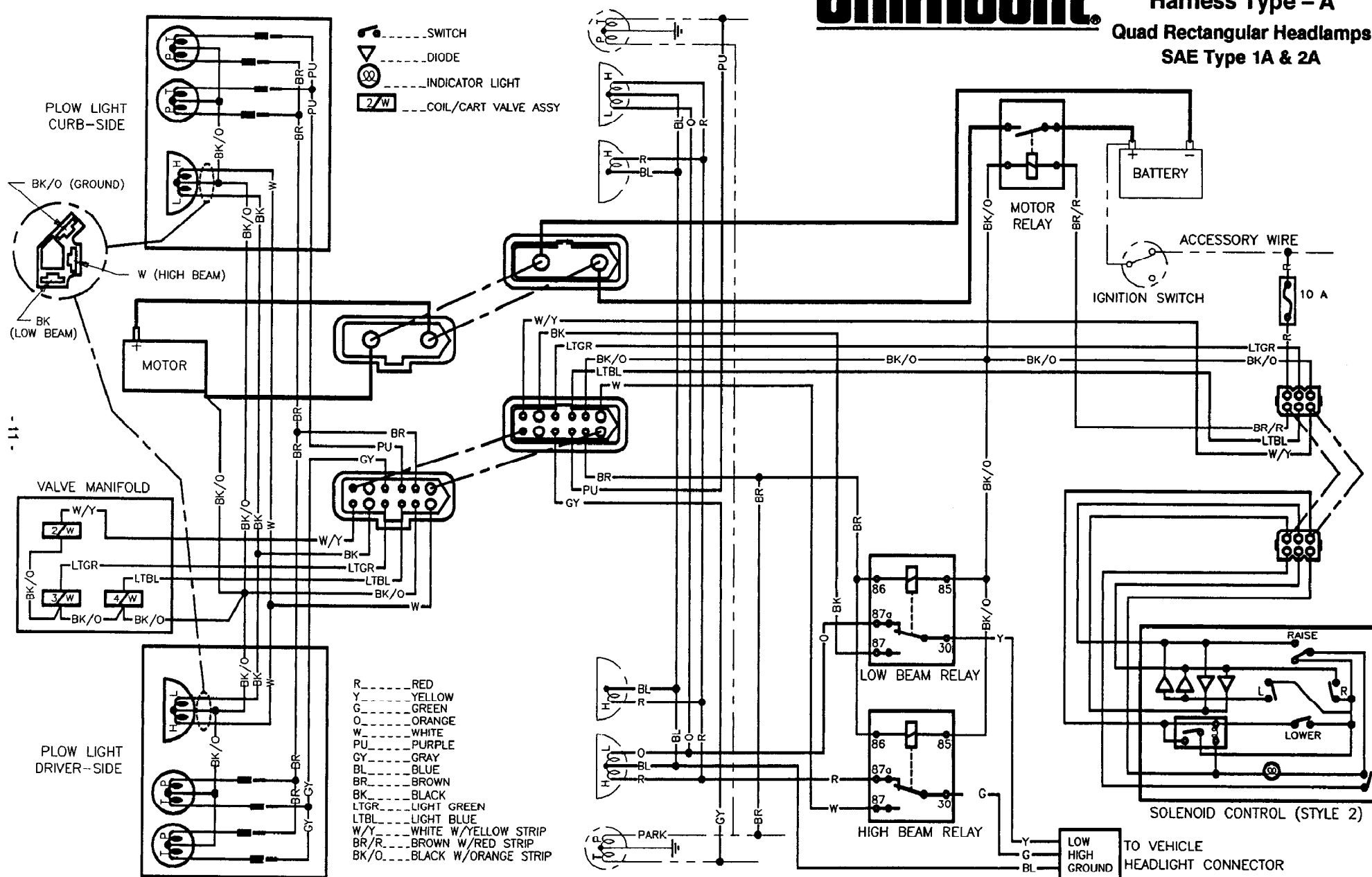

Solenoid Control - The control indicator light should light whenever the control ON/OFF switch and the ignition (key) switch are both turned ON and the plow plugs are disconnected.

The indicator light will also be on when the control and ignition (key) switches are ON and the plow plugs are disconnected. If the parking lights are turned on (with plow plugs disconnected), the indicator light will go out.

---

The following are registered® and unregistered™ Trade Marks of Douglas Dynamics, Inc.

WESTERN® ISARMATIC® Hydra-Turn® UniMount® Roll-Action™ PRO-GUARD™

Western reserves the right under its Product Improvement Policy to change construction details and furnish equipment when so altered without reference to illustrations or specifications used herein.