

1999 - FORD F 450 - F550 4 x 4

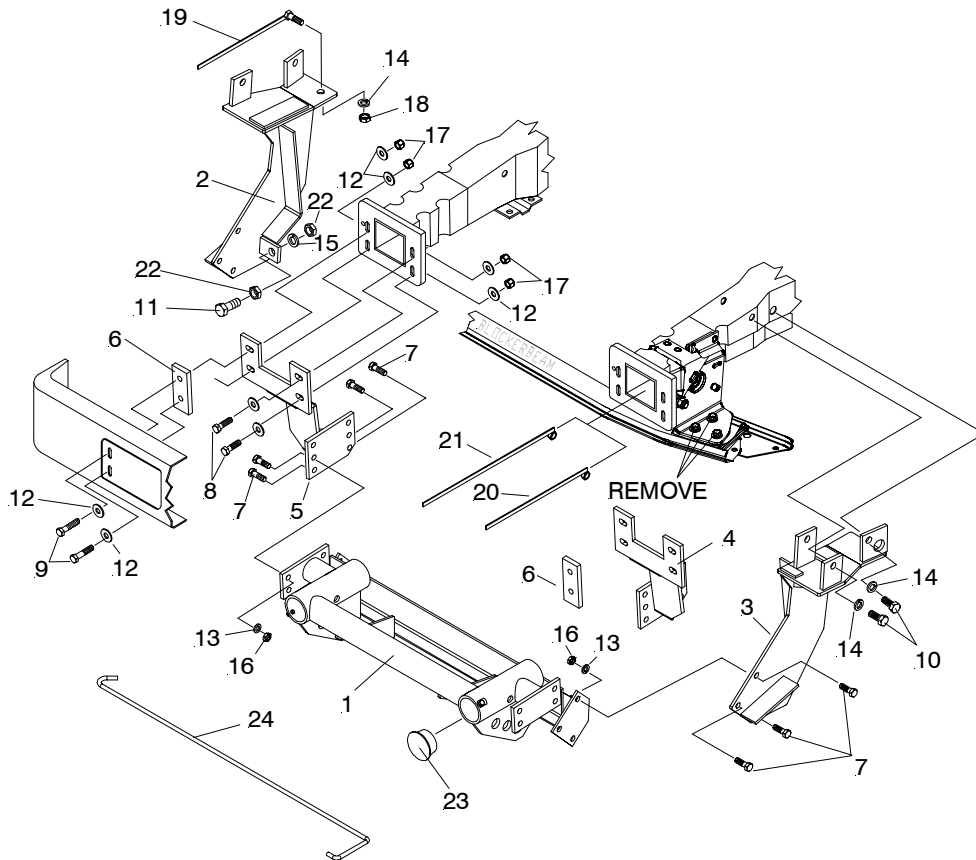

PARTS LIST

ITEM	PART NO.	QTY.	DESCRIPTION
	81022	1	FRAME ATTACHING KIT
1	80363	1	FRONT MOUNTING FRAME
2	80266	1	PUSH ARM, PS. SIDE
3	80267	1	PUSH ARM, DR. SIDE
4	80361	1	FRONT HANGER, DR. SIDE
5	80362	1	FRONT HANGER, PS. SIDE
6	* 11968	2	SPACER
7	* 20095	14	1/2-13 x 1 1/2" CAPSCREW
8	* 20096	4	1/2-13 x 1-3/4" CAP SCREW
9	* 20098	4	1/2-13 x 2-1/4" CAP SCREW
10	* 20139	5	5/8-11 x 1-1/2" CAPSCREW
11	* 20164	2	3/4-10 X 2" CAPSCREW
12	* 20355	16	1/2" FLATWASHER
13	* 20329	14	1/2 LOCKWASHER
14	* 20331	6	5/8 LOCKWASHER
15	* 20333	2	3/4 LOCKWASHER
16	* 8501001 009	14	1/2-13 NUT
17	* 20307	8	1/2-13 LOCKNUT ESNA
18	* 20530	1	5/8-11 NUT
19	80270	1	5/8-11 x 2" BOLT/HANDLE
20	80268	3	5/8-11 NUT/HANDLE (short)
21	80269	2	5/8-11 NUT/HANDLE (long)
22	* 8501003 015	4	3/4-10 JAM NUT
23	815000 146	2	REC. TUBE END CAP
24	819000 013	1	RELEASE HOOK

* ITEMS PACKED IN 80365 BOLT BAG

IMPORTANT NOTICE

End user must be given this instruction sheet prior to delivery of this Snow Plow.

The equipment you have just purchased should only be used on vehicles equipped with the Manufacturer's Snow Plow Preparation Packages. Snow Plowing without the original Snow Plow Preparation Package may damage your vehicle and the added weight to the equipment may impair the operation and control of the vehicle. Snow Plowing with a vehicle that the manufacturer does not recommend for that purpose may void your new vehicle warranty. If your vehicle is not originally equipped with the Snow Plow Package, additional parts may be necessary before snow plowing. Owners of these vehicles should consult their dealers before purchase or installation of such parts. **CAUTION:** the installation, on any vehicle, of these parts is not a full substitute for the original equipment Snow Plow Preparation Package.

Warning: Lift Arm extends beyond bumper of vehicle. To minimize damage from a front-end collision, Lift Arm should be removed from vehicle when Snow Plow is removed.

GENERAL INSTRUCTIONS:

Disconnect the vehicle battery or batteries before beginning installation. (Reconnect after installation is complete.) Do not burn holes into or weld pieces onto the vehicle frame. Use extreme caution when drilling any holes in the vehicle to prevent damage to brake lines, fuel lines, wiring, or any other vehicle components. Assemble parts and fasteners "finger tight" until instructions indicate final tightening. After first usage and periodically thereafter, retighten all fasteners to correct torque.

1. **PRELIMINARY:** Temporarily remove the front bumper from the vehicle. Save all fasteners - bumper will be reinstalled after snow plow attachments are installed. Screw a 3/4"-10 jam nut (16) all the way on to each of the 3/4"-10 x 2" capscrews (11). Place each of the 3/4"-10 x 2" capscrews / jam nut assemblies through the hole in the lower front ear of the driver's side and passenger's side push arms (2) & (3), with the heads of the capscrews (11) toward the front of the vehicle. Fasten with a 3/4" lockwasher (15) and 3/4"-10 jam nut (22) on each capscrow (11).
2. **FRONT HANGERS:** Once bumper is removed from the vehicle, attach the L.H. & R.H. Mount Assemblies (4) & (5) to the inside slots on front of vehicle frame horns using 1/2-13 x 1-3/4" bolts (8), flatwasher (12) and locknuts (17).
3. **FRONT MOUNTING FRAME** Place the mounting frame (1) front cross tube end plates onto the outside surface of the front hangers (4) & (5). Line up the four holes in each upper cross tube end plate with the lower four of holes in its respective front hanger (4) & (5). Attach using two 1/2"-13 x 1-1/2" capscrews (7), 1/2" lockwashers (13), and 1/2"-13 nuts (16) on each side.

4. **DRIVER'S SIDE PUSH ARM:** Temporarily remove the lower steering box bolt and washer from the driver's side frame rail. Save the bolt and washer - they have to be reinstalled after the driver's side push arm is installed. Place the upper rear section of the driver's side push arm (2) up and out through the space between the top surface of the driver's side leaf spring and the bottom surface of the frame rail. Line up hole in the inner bolting ear on the upper section of the push arm with the hole in the inner surface of the frame rail. Insert a 5/8"-11 x 1-1/2" capscrow (10) and 5/8" lockwasher (14) through the hole in the bolting ear and the frame rail. Fasten using a short 5/8-11 nut/handle (20) placed inside the frame rail from the open front end. Line up the three holes in the lower front section of the push arm (2) with the holes in the driver's side lower cross tube end plate of the mounting frame (1). Attach using three 1/2"-13 x 1-1/2" capscrews (7), 1/2" lockwashers (13), and 1/2-13 nuts (16). Reinstall and tighten the lower steering box bolt and washer back through the driver's side frame rail into the steering box.
5. **PASSENGER'S SIDE PUSH ARM** Place the upper rear section of the passenger's side push arm (3) up and out through the space between the top surface of the passenger's side leaf spring and the bottom surface of the frame rail. Place 5/8"-11 x 2" bolt/handle (19) inside the passenger's side frame rail from the open front end. Insert the bolt on the bolt/handle (19) down through the hole in the bottom surface of the frame rail and through the hole in the horizontal frame plate of the passenger's side push arm (3). Fasten using 5/8" lockwasher (14) and a 5/8-11 nut (18). Line up the three holes in the lower front section of the push arm (3) with the holes in the passenger's side lower cross tube end plate of the mounting frame (1). Attach using three 1/2"-13 x 1-1/2" capscrews (7), 1/2" lockwashers (12), and 1/2"-13 nuts (16).
6. **FASTENERS:** Tighten the tow hook bolts and 1/2" fasteners installed into the push arms (2) & (3), mounting frame (1), front hangers (4) & (5) and vehicle frame to the specified torques. Adjust the 3/4" capscrews (11) with the 3/4" jam nuts (22) so that the heads of the capscrews are tight against the lower cross tube of the mounting frame. Lock the 3/4" capscrews (11) in place using the rear jam nuts (22). Using the holes in each of the two outer vertical bolting ears on the push arms (2) & (3), as guides, drill two 5/8" diameter holes through the outer surface of each frame rail. Insert a 5/8"-11 x 1-1/2" capscrow (10) with a 5/8" lockwasher (14) through each hole in the vertical bolting ears of the push arms (2) & (3) and the drilled holes in the frame rails. Fasten and tighten the 5/8"-11 x 1-1/2" capscrews (10) using a short 5/8"-11 nut/handle (20) and a long 5/8"-11 nut/handle (21) placed inside each frame rail from the open front ends.
7. **BUMPER:** Reinstall the bumper using 1/2-13 x 2-1/4" bolts (9), flatwashers (12), Spacers (6) and locknuts (17). **Note: Spacer (6) is to be added between the bumper and clevis frame (1) as per illustration.**
8. **LIFT FRAME:** Clean paint and burrs from the outside tube ends of the lift frame and the inside surfaces of the receiver tubes of the front mounting frame (1).

SPECIAL NOTE: Liberally coat the entire tube ends of the lift frame, the inside surfaces of the receiver tubes and threads of the slack adjusting bolts on the receiver tubes with chassis or anti-seize lubricant.

Back off the slack adjusting bolts on the receiver tubes until they no longer protrude inside the tubes. Slide the lift frame into the receiver tubes of the front mounting frame (1) until the fastening holes line up. Tighten the slack adjusting bolts on the receiver tubes until the lift frame will just slide in and out of the receiver tubes. Secure the lift frame to the front mounting frame using 5/8" hinge pins (26) and hairpin cotters (27). Found in the 81500 carton.

Items found in the Common Attachment Kit 81500:

9. **LIFT ARM:** Install the lift arm (24) and lift cylinder or electric hydraulic unit onto the lift frame using the 5/8"-11 x 5- 1/2" capscrew (25) through the upper lift frame ears and the rear lift arm hole. Place a 5/8"-11 x 4-3/4" capscrew through the front lift arm hole and the ram end of the lift cylinder or electric hydraulic unit. Place a 5/8"-11 x 3-1/4" capscrew through the lower lift frame ears and stationary end of the lift cylinder or electric hydraulic unit. Fasten the three 5/8"-11 capscrews using three 5/8"-11 locknuts (32). See Hardware hydraulic carton.
10. **LIFT CHAIN:** Attach each end of the lift chain (40) to the two holes in each of the diagonal braces of the push frame using 7/16" -14 "U" bolts (41), 7/16" lockwashers (43), and 7/16"-14 nuts (42).
11. **PUSH FRAME:** Install the push frame onto the plow blade with the upper and lower pivot holes lined up with the pivot holes in the back of the plow blade. Insert the shorter pivot pin (36) down through the upper pivot holes. Insert the longer pivot pin (39) down through the lower pivot holes. Secure the pivot pins (36) & (39) using 1/4" x 2" cotter pins (23).
12. **ANGLE CYLINDERS:** Install the angle cylinders between the push frame and the ears on the back side of the plow blade with the rod end of the cylinders toward the plow blade. The elbows in the ports of the angle cylinders should be between the angle cylinders and the push frame. **NOTE: When installing the angle cylinders on 8' and 8-1/2' plow blades, place four 1-1/4" flatwashers (30) between each lower push frame ear and the stationary end of each angle cylinder.** Attach the stationary end of the angle cylinders to the push frame using the two shorter cylinder pins (22). Attach the rod ends of the angle cylinders to the back side of the plow blade using the two longer cylinder pins (44). Secure the cylinder pins using 1/4" x 2" cotter pins (23).
13. **PLOW MARKERS:** Attach each plow marker (33) to the two holes in the upper outer surface of each end rib of the plow blade using two 5/16"-18 x 11" capscrews (35), 5/16" lockwashers (37), and 5/16"-18 nuts (38).
14. **HOOK UP PINS:** Compress each hook up pin spring (50) slightly and place them between the inner most ear and the center ear on each side of the push frame with the hole through the center of each spring lined up with the pin holes in the push frame ears. Insert each hook up pin (48) through the pin hole in each inner most ear of the push frame , through the center of the springs (50), and out through the center and outside ears on each side of the push frame. Compress the hook up pin springs (50) slightly and secure the hook up pins (48) using a 1" snap ring (49) in the snap ring groove of each hook up pin (48). (The snap rings should be between the end of the spring and the inner surface of each of the center ears on the push frame.)



15. **PLOW TO VEHICLE ATTACHING:** Pull back and lock the spring loaded hook up pins (48) on each side of the push frame . Attach the lift chain to the lift arm hooks and lift the back end of the push frame up level using the vehicle hydraulics. Line up the spring loaded hook up pins with the corresponding set of holes in the lower part of the mounting frame. Unlock the spring loaded hook up pins so that they go completely through the holes in the mounting frame and the push frame ears. Adjust the lift chain at the lift chain hooks on the lift arm so that the plow blade will lift fully and also be able to follow the ground contour while plowing. **NOTE: If the lift chain does not pull evenly, shorten the longer side by attaching at a different link or at half a link where the chain is attached to the push frame with the 7/16" "U" bolts.**
16. **PUSH FRAME STOP BOLTS:** Screw a 5/8"-11 jam nut (29) all the way onto each of the 5/8"-11 x 3" full thread capscrews (28). Place the capscrew / jam nut assemblies up through the ears on each side of the lower lift frame with the heads of the capscrews down. Fasten with a 5/8" lockwasher (31) and jam nut (29). Adjust the 5/8"-11 x 3" full thread capscrews (28) with the jam nuts (29) so that the heads of the capscrews (28) contact the push frame before the upper pivot section of the push frame contacts the lift arm or the lift cylinder / out front electric hydraulic unit while lifting plow or stacking snow. **NOTE: If the push frame is attached to a different set of connecting holes on the mounting frame, the push frame stop bolts should be checked and may need to be readjusted to prevent the push frame from contacting the lift arm, or the lift cylinder / out front electric hydraulic unit while lifting plow or stacking snow.**

CAUTION: CHECK THE TRIPEDGE ADJUSTMENT AT THIS TIME.

- A. **THE SPRINGS ARE PROPERLY ADJUSTED WHEN A PIECE OF PAPER CAN BE PLACED BETWEEN EACH COIL.**
- B. **IF THE TRIPEDGE SPRINGS NEED ADJUSTMENT, LOOSEN THE BOTTOM LOCK NUT ON BOTH SPRING ASSEMBLIES. ROTATE THE TOP NUT UNTIL THE SPRINGS ARE PROPERLY ADJUSTED.**
- C. **BE SURE TO TIGHTEN THE BOTTOM LOCK NUT SECURELY ON BOTH ASSEMBLIES TO THE TOP NUT TO PREVENT LOOSENING OF THE ASSEMBLIES.**

INSTRUCTIONS ARE SUBJECT TO CHANGE WITHOUT NOTICE.

TORQUE CHART FOOT LBS.

Bolt Nut Size	Gr. 2 	Gr. 5 	Gr. 8 
1/4 - 20	4 - 5		
5/16 - 18	9 - 11		
3/8 - 16	17 - 20		
7/16 - 14		26 - 29	60 - 66
1/2 -13		42 - 46	90 - 100
5/8 - 11		64 - 72	179 - 198
3/4 - 10		127 - 141	
		227 - 251	

Meyer Products or Diamond Equipment assumes no responsibility for installations not made in accordance with these instructions.