



**WESTERN PRODUCTS**  
 7777 NORTH 73RD STREET  
 P.O. BOX 23045  
 MILWAUKEE, WISCONSIN 53223

Box No. 59950  
 Model No. 1510  
 Chevrolet and GMC  
 1973 and Later  
 Light Truck 4x4  
 Front Frame Lift-Mount  
**INSTALLATION INSTRUCTIONS**

SIZE	RECOMMENDED FASTENER TORQUE CHART		
	TORQUE IN FOOT POUNDS		
	GRADE 2	GRADE 5	GRADE 8
1/4 - 20	6	9	13
5/16 - 18	11	18	28
3/8 - 16	19	31	46
3/8 - 24	24	46	68
7/16 - 14	30	50	75
1/2 - 13	45	75	115
9/16 - 12	66	110	165
5/8 - 11	93	150	225
3/4 - 10	150	250	370
7/8 - 9	202	378	591
1 - 8	300	583	893

These torque values apply to lift mount fasteners except those noted in the instructions where motion is desired

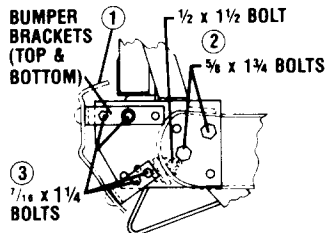

1973 THRU 1980

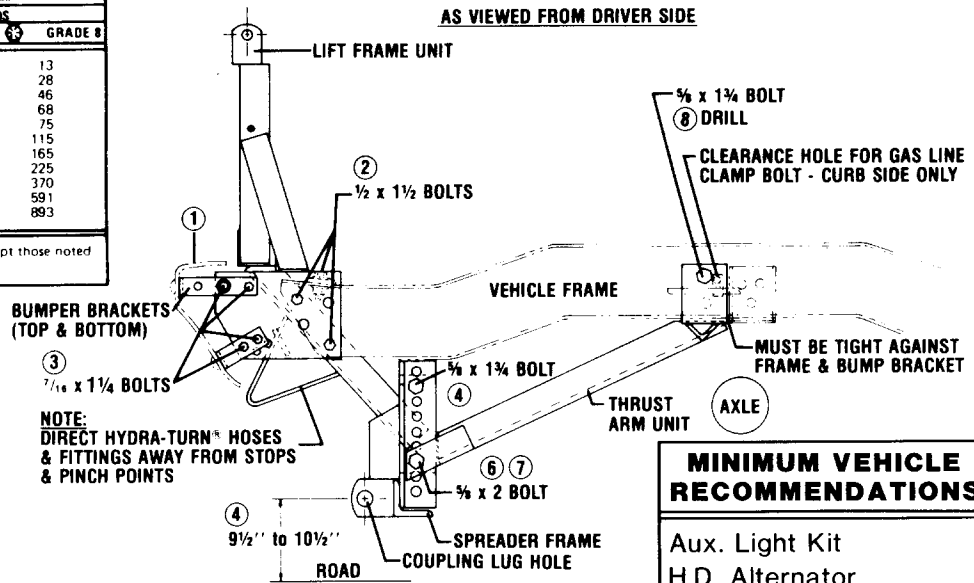

**MINIMUM VEHICLE RECOMMENDATIONS**

Aux. Light Kit  
 H.D. Alternator  
 H.D. Battery  
 H.D. Frt. Springs  
 Manual Locking Front Hubs

**IMPORTANT:** Read instructions before assembling. Bolts should be finger tight until the installation is completed to allow sufficient adjustment for aligning holes and locating parts to vehicle frame. Preventive maintenance can prevent accidents. Regularly inspect all components and repair or replace any worn, loose or damaged parts immediately. Remember to use standard methods and practices when attaching snowplow including wearing safety glasses during drilling. Install snowplow as follows:

**LIFT ASSEMBLY:**

**IMPORTANT:** Some models of Chevrolet/GMC light truck class vehicles have an Air Dam mounted under the front bumper. This Air Dam interferes with the installation of Lift-Mounts and must be removed to facilitate installation of this snowplow mounting. The Air Dam must be retained and replaced whenever the snowplow Lift-Mount is removed from the vehicle.

**1981 AND LATER**

1. Disconnect park/turn lights from bumper. Remove bumper from vehicle and bumper brackets from frame horn.
2. Align the two 9/16" holes in the lift frame side plates to the vehicle frame bumper bracket holes and top tab of lift frame to vehicle frame, secure with fasteners shown above placing flat washers to inside of frame and top tab on lift frame.
3. Install top and bottom bumper brackets with furnished fasteners, as shown in diagram above. When replacing bumper use existing fasteners through bumper brackets and secure with existing flat washers and nuts. Attach outboard top and bottom bumper brace extensions to bumper using existing fasteners through the large hole in extensions. Fasten other ends of bumper brace extensions to the diagonal bumper braces using existing 1/2" bolts, flat washers to slots, hex nuts and furnished lock washers. Replace park/turn lights to bumper.

**1973 THRU 1980**

1. Remove the bumper from the vehicle, also remove bumper clips from top of vehicle frame.
2. Align the two 11/16" holes in lift frame side plates to the slots in the vehicle frame, and slot in frame end to lower lift frame tab. Secure with furnished fasteners shown in inset above. Install bumper brackets as shown in inset.
3. Install top and bottom bumper brackets with furnished fasteners, as shown in inset above. When replacing bumper, use existing fasteners through the bumper brackets and secure with existing flat washers and nuts. Fasten outboard diagonal bumper braces to the bumper using furnished pipe spacers, 1/2" x 5" carriage bolts, flat washers and locknuts.

**MOUNT ASSEMBLY:**

4. Attach the spreader frame to lift frame with center of coupling lug holes between 9-1/2" and 10-1/2" from road. Use 5/8" x 1-3/4" bolts in top hole.
5. On curb side, thrust arm attaching bar has clearance holes for rivets in bottom frame flange and for gas line clamp bolt in frame side member located in front of axle bump bracket. Drill top hole only for 5/8" bolt. See **CAUTION** note in para. 8.
6. Attach front of thrust arm as shown with 5/8" x 2" bolts and locknuts.
7. Driver side, attach bottom of thrust arm as shown. Hold top of both thrust arms against bottom of vehicle frame and mark holes.
8. Drill 5/8" holes both sides, align to top hole in thrust arm bracket. On curb side drill top or bottom hole whichever provides greatest amount of clearance to gas line. (**CAUTION!** Before drilling be sure drill will not damage brake or gas line.) Fasten arms using 5/8" x 1-3/4" bolts and locknuts. Tighten all bolts securely.

**HYDRAULICS:** Mount the Hydraulic System using the instructions furnished in the Hydraulic Carton.

Box No. 59950  
 Model No. 1510  
 Chevrolet and GMC  
 1973 and Later  
 Light Truck 4x4  
 Front Frame Lift-Mount

**PARTS DIAGRAM & LIST**

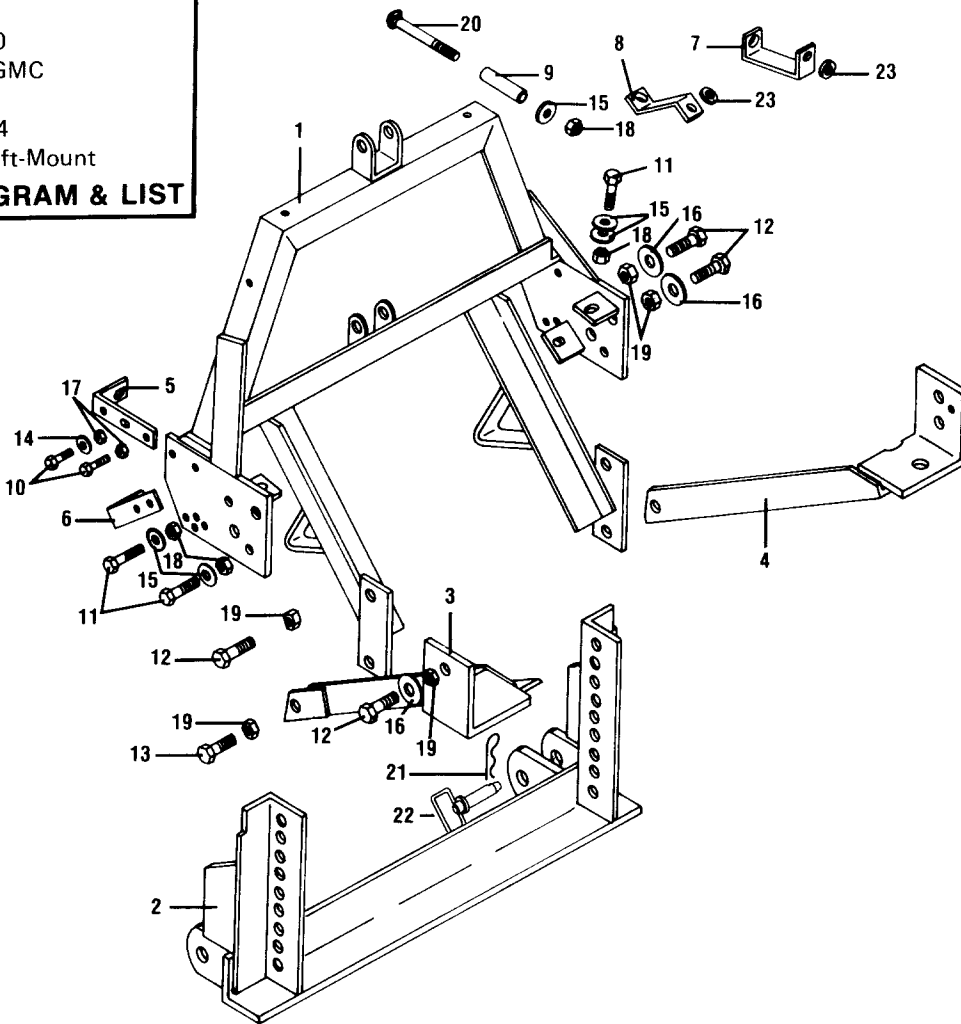

3146-8312  
 3147-8312

Item	Part No.	Quantity	Description
1	60080	1	Lift-Frame Unit
2	59595	1	Spreader Frame Unit
3	59553	1	Thrust Arm Unit – Driver Side
4	59655	1	Thrust Arm Unit – Curb Side
5	60047	2	Top Bumper Bracket
6	60048	2	Bottom Bumper Bracket
7	60051	2	Top Bumper Brace Extension – 1981
8	60052	2	Bottom Bumper Brace Extension – 1981
9	59067	2	Pipe Spacer – 1973-'80
10	90066	8	Capscrew – 7/16"-14 x 1-1/4" Long – Grade 5
11	90100	6	Capscrew – 1/2"-13 x 1-1/2" Long – Grade 5
12	90128	8	Capscrew – 5/8"-11 x 1-3/4" Long – Grade 5
13	90129	2	Capscrew – 5/8"-11 x 2" Long – Grade 5
14		2	Flat Washer – 7/16"
15		8	Flat Washer – 1/2"
16	91139	6	Flat Washer – 5/8" – SAE
17	91334	8	Locknut – 7/16"-14 – Nylon Insert Type
18	91335	6	Locknut – 1/2"-13 – Nylon Insert Type
19	91337	10	Locknut – 5/8"-11 – Nylon Insert Type
20	90253	2	Carriage Bolt – 1/2"-13 x 5" Long
21	91965	2	Hairpin Cotter – 5/32" x 2-15/16" O/A Length
22	93028	2	Hitch Pin – 1" x 3-1/2" Long
23	91205	4	Lock Washer – 1/2"
	Parts Not Shown 55928	1	Battery Cable Adaptor

**NOTE:** Only those items indicated with a **Part Number** are available for Service.

**INSTALLATION INSTRUCTIONS  
FOR — IIIa CONTROL  
TO VEHICLE INSTRUMENT PANEL  
CHEVROLET & GMC**

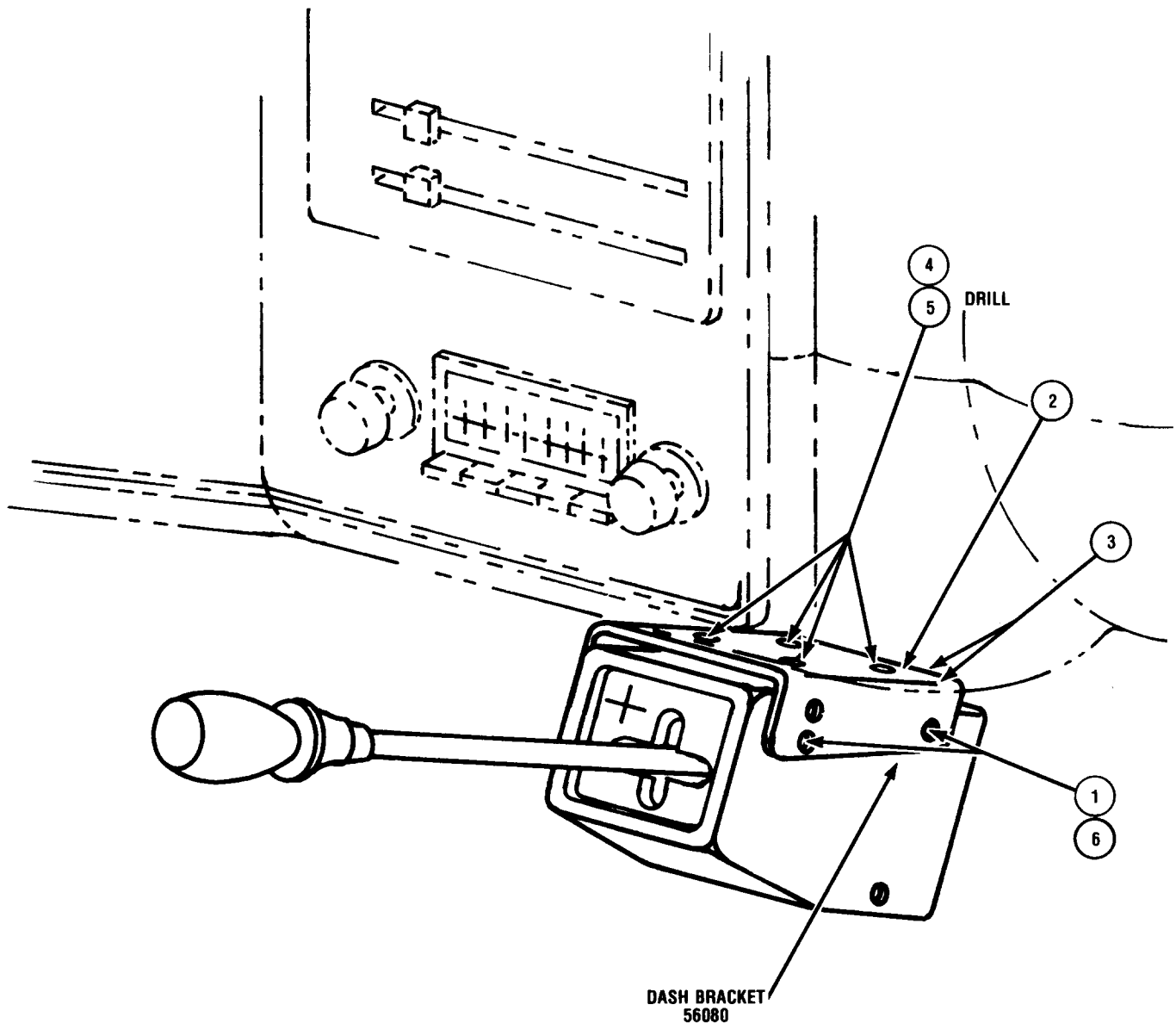

1. Secure the dash bracket to the IIIa Control using 4-No. 8 x 5/8" long hex head screws.
2. Locate IIIa Control to the dash as shown, below and to the right of the radio, or whatever is most convenient. The bracket should fit fairly flat against the bottom surface of the dash. Verify that IIIa Control lever will clear vehicle components in all positions and for adequate drill clearance before drilling holes.
3. Mark this location.
4. Remove the bracket from the IIIa Control. Place the bracket in the selected location under the dash and mark all 4 holes.
5. Drill 1/8" diameter holes into the dash to align to the holes in the bracket. Secure using No. 10 sheet metal screws and lock washers.
6. Place IIIa Control into bracket and fasten in desired position.

## A-FRAME STOP MODIFICATION INSTRUCTIONS

With snowplows mounted to vehicles having small tire size options, the blade lift may be less than desirable. If this condition exists on any installation, the height of blade lift can be increased by cutting and rewelding the A-frame stops on the mount as shown in the sketch below.

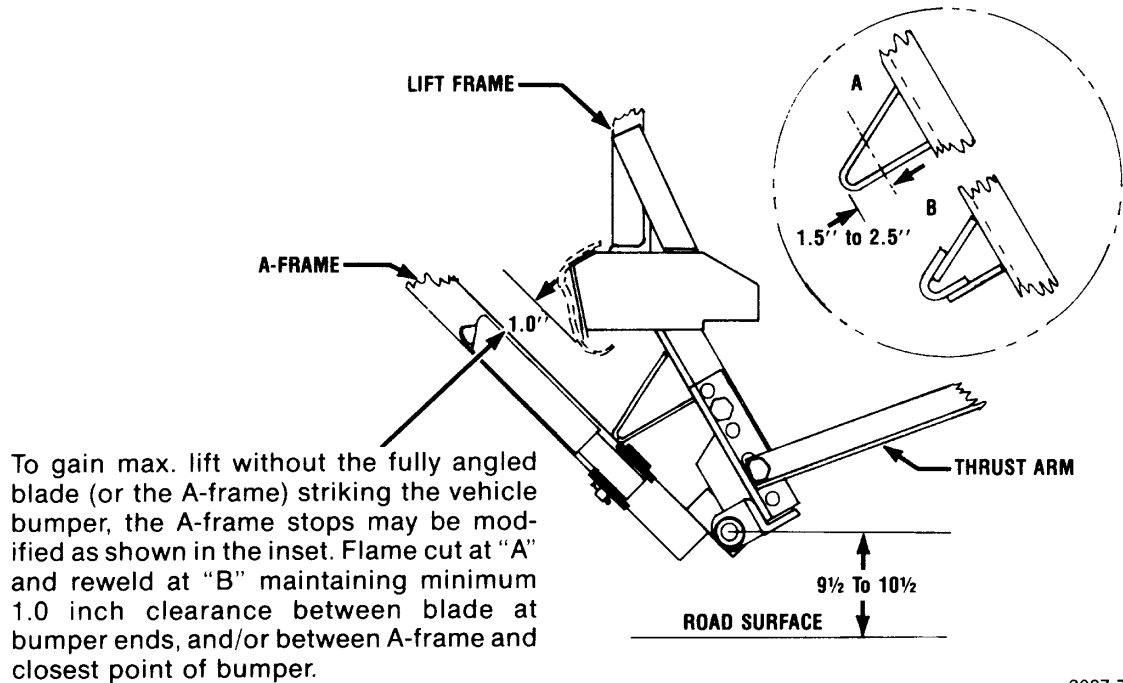

3027-7707

## INSTALLATION INSTRUCTIONS FOR 59700 BLADE GUIDE ASSEMBLY

The following instructions simply outline the attachment of this blade guide assembly.

- Step 1. Lower blade to ground level.
- Step 2. If hole is not pre-drilled, drill one 11/32" hole, 1-3/16" down and 1" out on the outside rib of blade. See diagram below.
- Step 3. Insert pointed end of clamp into coil of guide. Attach guide to rib using top hole of clamp. Secure assembly using supplied 5/16" x 1" bolt and locknut. Tighten until guide will stand alone perpendicular to road surface.
- Step 4. If hole is not pre-drilled, use lower hole of clamp as locator, drill bottom hole 11/32".
- Step 5. Bolt lower hole in place. Finish securing top bolt.
- Step 6. Attach other side following above steps.

Pictorial view supplied below. Remember to use standard methods and practices in attaching blade guides including wearing safety glasses during drilling.

### PARTS LIST

#### 59700 - BLADE GUIDE ASSEMBLY

ITEM	PART NO.	QUAN.	DESCRIPTION
1	59697	2	Blade Guide Rod, S-Hook & Flag
2	59694	1	Flag
3	59696	1	S-Hook
4	59691	1	Blade Guide Rod
5	59946	2	Clamp
6		4	Capscrew 5/16 - 18 x 1 Gr 2
7		4	Locknut 5/16 - 18 Nylon Insert

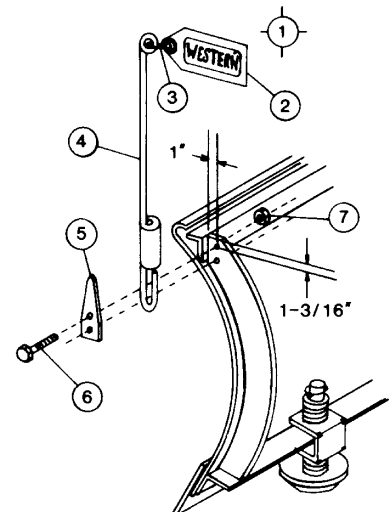

3009-7911

The following are registered® or unregistered™ Trade Marks of Douglas Dynamics, Inc.  
WESTERN® ISARMATIC® Hydra-Turn® Roll-Action™

Western reserves the right under its Product Improvement Policy to change construction or design details and furnish equipment when so altered without reference to illustrations or specifications used herein.