

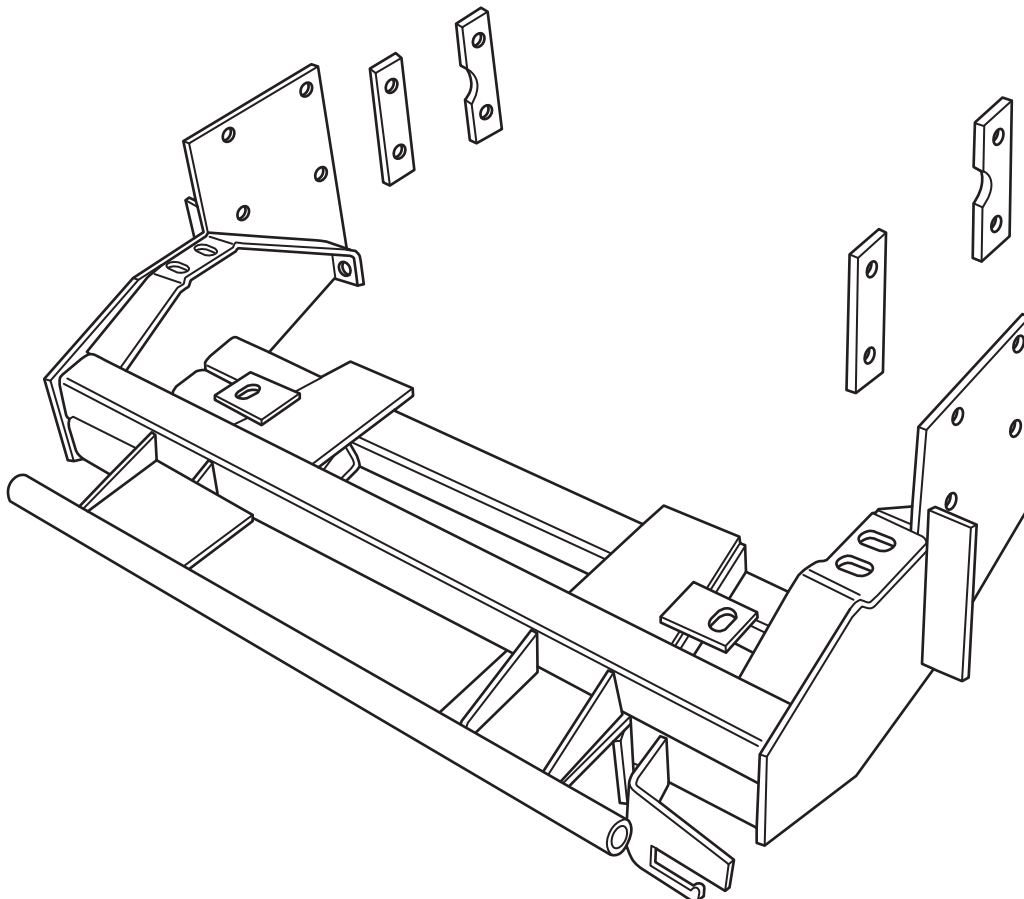

HOME-PRO[®] 3000

**1998 – Toyota Tacoma
(With Max. GVWR & Max. FGAWR ONLY)**

Vehicle Mounting Kit: 1FK22



Curtis Industries Inc. LLC, 111 Higgins St., Worcester, MA 01606 TEL: (800) 343-7676 FAX: (508) 854-3377 For Parts and information visit us at www.Curtisindustries.net
Curtis Industries Inc. LLC, reserves the right to change product design or specifications without notice or liability.
Curtis Snow Plows are protected by the following U.S. Patent Numbers: 6,145,222 and 6,209,231 Licensed under U.S. Patent Number 5,568,694 & Canadian Patent Number 2,137,853.
Other patents pending.

1FK22 Vehicle Mount Kit Parts List

Item #	Description	Qty.
1	Mounting Frame	1
2	Skid / Splash Pan	1
3	Long Bolting Bar	2
4	Short Bolting Bar	2
Hardware Bag Components Included In This Kit		
5	M12-1.25 x 35MM Bolt, Plated, Gr. 10.9	4
6	M12 Lock Washer, Plated	4
7	M12 Flat Washer, Plated	4
8	1/2"-13 x 3-1/2" Bolt, Gr.5, Plated	4
9	1/2"-13 x 4" Bolt, Gr.5, Plated	4
10	1/2" Lock Washer, High Strength, Plated	8
11	1/2"-13 Hex Nut, Plated	8
12	5/8"-11 x 2-1/2" Carriage Bolt, Plated, Gr. 5	2
13	5/8" Lock Washer, Plated	2
14	5/8"-11 Hex Jam Nut, Plated	4



WARNING

It is highly recommended that front "helper springs", "airshocks", or other similar devices be installed onto this vehicle to prevent the front suspension from "bottoming out" while carrying a snow plow.

Vehicle must be properly "ballasted" by placing ballast weight behind the centerline of Rear Axle so that no more than 62% of the total weight of the Vehicle, Snow Plow, Driver, Ballast weight, (and any cargo) is placed on the Front Axle while at the same time not exceeding the Gross Vehicle Weight Rating and Front or Rear Gross Axle Weight Ratings.

1FK22 Mounting

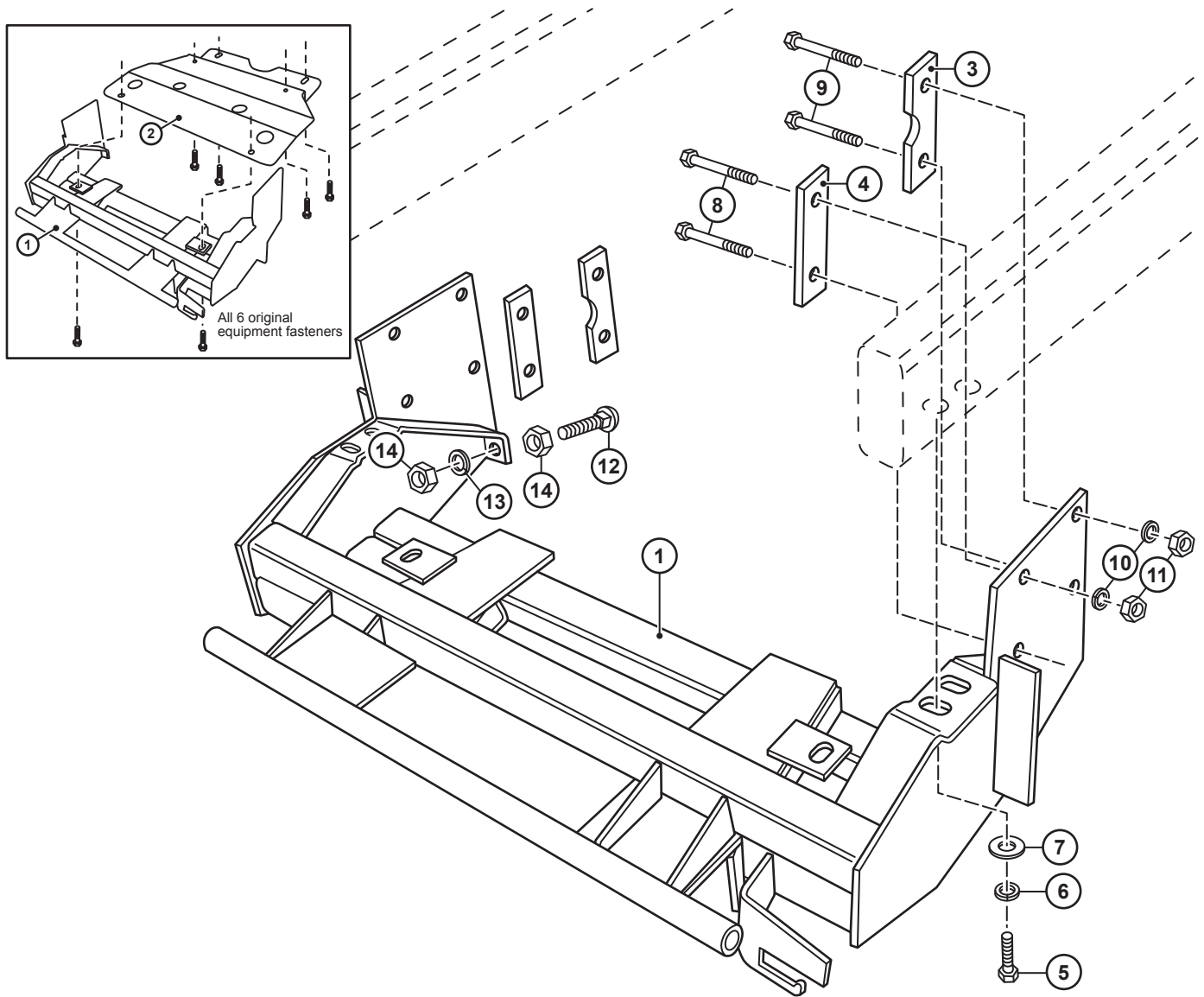

Curtis Industries, LLC. reserves the right to change product design or specifications without notice or liability. Curtis Snow Plows and Truck equipment should only be used on vehicles equipped with the manufacturer's Snow Plow preparation package. Snow Plowing without the original snow plow preparation package may damage your vehicle and the added weight of the equipment may impair the operation and control of the vehicle.

1FK22: 1998 – Toyota Tacoma

Mounting Kit Installation Instructions

1. VEHICLE PREPARATION

- (1a.) Remove and store the original equipment front skid / splash pan. Save the original equipment fasteners. Remove and store the tow hook and tie down brackets at the front of the frame rails (if the vehicle is so equipped). The tow hook and tie down brackets will not be re-installed with the mounting frame (1) attached. Remove and discard the front plastic rivet holding the rubber filler to the outside of each frame rail.
- (1b.) Screw a 5/8"-11 hex jamb nut (14) all the way onto each of the 5/8"-11 x 2-1/2" carriage bolts (12). Place each carriage bolt / jamb nut assembly into the push ears at the rear of the mounting frame (1) with the heads of the carriage bolts toward the rear of the vehicle. Fasten loosely using a 5/8"-11 jamb nut (14), and 5/8" lock washer (13) on each carriage bolt / jamb nut assembly.



NOTE

All fasteners should remain loose or "finger tight" until all components have been attached to vehicle or installation instructions specify tightening.

2. MOUNTING FRAME

- (2a.) Lift the mounting frame (1) up under the front of the vehicle with the rear vertical plates between the vertical outer surfaces of the frame rails and with the holes in the front horizontal brackets lined up with the threaded holes in the lower horizontal surfaces that the tow hook and tie down bracket bolts were removed from.
- (2b.) Loosely fasten the mounting frame (1) to the frame rails (at the threaded holes) using four M12-1.25 x 35mm bolts (5), M12 flat washers (7), and M12 lock washers (6).
- (2c.) From inside the engine compartment, insert 1/2"-13 x 3 1/2" bolts (8) through the holes in the short bolting bars (4) and into the front two holes in the vertical plates on each side of the mounting frame (1).
- (2d.) Insert 1/2"-13 x 4" bolts (9) through the holes in the long bolting bars (3) and into the rear holes in the vertical plates on each side of the mounting frame (1). Fasten using 1/2" lock washers (10) and 1/2"-13 nuts (11).
- (2e.) Tighten the four M12-1.25 x 35mm bolts (5) and all 1/2" fasteners holding the mounting frame (1) to the vehicle frame rails.
- (2f.) Adjust the 5/8"-11 x 2-1/2" carriage bolts (12) using the rear 5/8"-11 jamb nuts (14) so that the heads of the carriage bolts are tight against the front of the vehicle front suspension cross member. Lock the 5/8"-11 x 2-1/2" carriage bolts (12) in place by tightening the front 5/8"-11 jamb nuts (14).

3. SKID / SPLASH PAN

Install the new skid / splash pan (2), (included with the 1FK 22 mounting frame kit) from under and behind the previously installed mounting frame (1) with the two middle holes and two rear holes lined up with the original skid / splash pan threaded mounting bolt holes on the vehicle and with the two threaded front holes lined up with the slotted holes in the brackets on the mounting frame (1). Fasten and tighten using six of the original equipment fasteners.

IMPORTANT

If mounting frame (1) and new skid / splash pan (2) are ever removed from the vehicle, the original equipment skid / splash pan must be reinstalled before the vehicle is put back into service.

4. FINAL ADJUSTMENT AND INSPECTION

Inspect the mounting and skid / splash pan attachment bolts to be certain that they are all in place and that they are all tight.

