

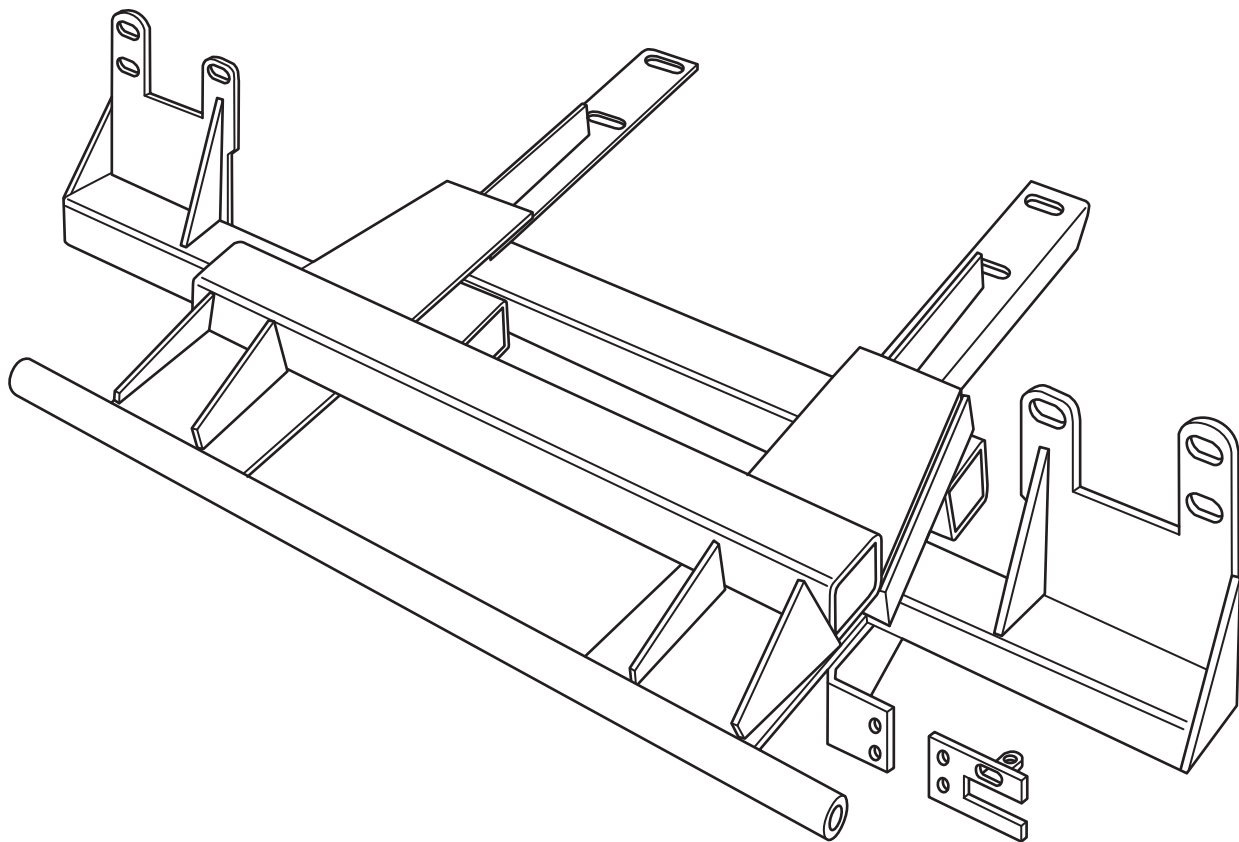

HOME-PRO[®] 3000

**2005 - Toyota Tacoma, Reg. Cab, 4Cyl.
Manual Transmission (With Max. GVWR & Max. FGAWR ONLY)**

Vehicle Mounting Kit: 1FK33



Curtis Industries Inc. LLC, 111 Higgins St., Worcester, MA 01606 TEL: (800) 343-7676 FAX: (508) 854-3377 For Parts and information visit us at www.Curtisindustries.net
Curtis Industries Inc. LLC, reserves the right to change product design or specifications without notice or liability.
Curtis Snow Plows are protected by the following U.S. Patent Numbers: 6,145,222 and 6,209,231 Licensed under U.S. Patent Number 5,568,694 & Canadian Patent Number 2,137,853.
Other patents pending.

1FK33 Vehicle Mount Kit Parts List

Item #	Description	Qty.
1	Mounting Frame	1
Hardware Components Included In Plow Light Harness Kit P/N: 1TBP51E1		
1a	Dual Plug Harness Bracket	1
-	10-32 x 3/4" Hex Head Screw, Plated	2
-	10-32 Nylock Lock Nut, Plated	2
-	8-32 x 1" Hex Head Screw, Plated	1
-	8-32 Nylock Lock Nut, Plated	1
-	#8 Nylon Flat Washer, 3/4" O.D.	1
-	#8 Flat Washer, SAE, Plated	1



WARNING

It is highly recommended that front "helper springs", "airshocks", or other similar devices be installed onto this vehicle to prevent the front suspension from "bottoming out" while carrying a snow plow.

Vehicle must be properly "ballasted" by placing ballast weight behind the centerline of Rear Axle so that no more than 62% of the total weight of the Vehicle, Snow Plow, Driver, Ballast weight, (and any cargo) is placed on the Front Axle while at the same time not exceeding the Gross Vehicle Weight Rating and Front or Rear Gross Axle Weight Ratings.

1FK33 Mounting

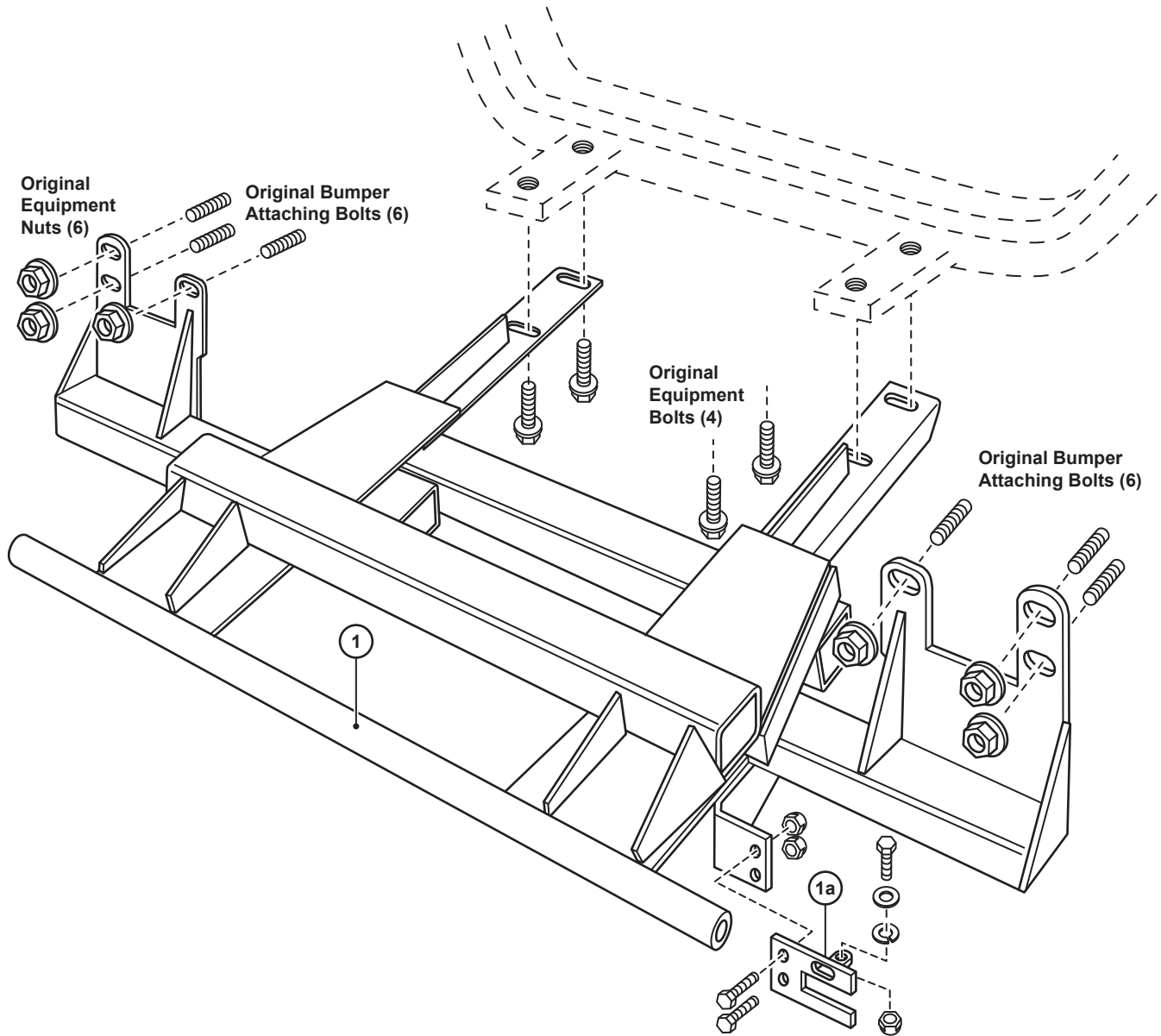

Curtis Industries, LLC. reserves the right to change product design or specifications without notice or liability. Curtis Snow Plows and Truck equipment should only be used on vehicles equipped with the manufacturer's Snow Plow preparation package. Snow Plowing without the original snow plow preparation package may damage your vehicle and the added weight of the equipment may impair the operation and control of the vehicle.

1FK33: 2005 - Toyota Tacoma, Regular Cab, 4Cyl., Manual Transmission

Mounting Kit Installation Instructions

1. VEHICLE PREPARATION

(1a.) Remove and store the original equipment front skid / splash pan and the two longitudinal channel struts bolted between the blocker beam (just behind the front bumper) and the front suspension cross member. Remove the three nuts from the bumper attaching bolts at the front of each frame rail. Save all the original equipment fasteners, some will be used to attach the plow mounting, save the remainder for possible reinstallation if the plow mounting is removed. The skid / splash pan and longitudinal channel struts will not be re-installed with the mounting frame (1) attached.



NOTE

All fasteners should remain loose or "finger tight" until all components have been attached to Vehicle or installation instructions specify tightening.

IMPORTANT

If the plow mounting frame (1) is ever removed from the vehicle, the original equipment skid / splash pan and longitudinal channel struts must be reinstalled before the vehicle is put back into service.

2. MOUNTING FRAME

Lift the mounting frame (1) up under the front of the vehicle with the slotted holes in the front brackets over the six bumper attaching bolts at the front of the frame rails. Fasten using the six original equipment nuts removed previously. Fasten the rear push angles of the mounting frame (1) to the threaded holes (that the rear of the longitudinal struts were attached to) in the front suspension cross member using four of the original equipment fasteners. Tighten all fasteners fully.

3. FINAL ASSEMBLY AND INSPECTION

Inspect the mounting attachment bolts to be certain that they are all in place and that they are all tight.

4. OPTIONAL PLUG MOUNT BRACKET INSTALL



NOTE

Install the Plug Mount Bracket if the harness will be mounted on the frame kit, otherwise, the harness may be routed through the grill, bumper, etc.

Using (2) 10-32 x 3/4" hex bolts and nylon locknuts, fasten the Plug Mount Bracket to the Plug Mount Bracket Mounting Tab located on the drivers side of the frame kit receiver. The included 8-32 hardware is used for mounting the hi-amp battery leads to the Plug Mount Bracket, if used.

