

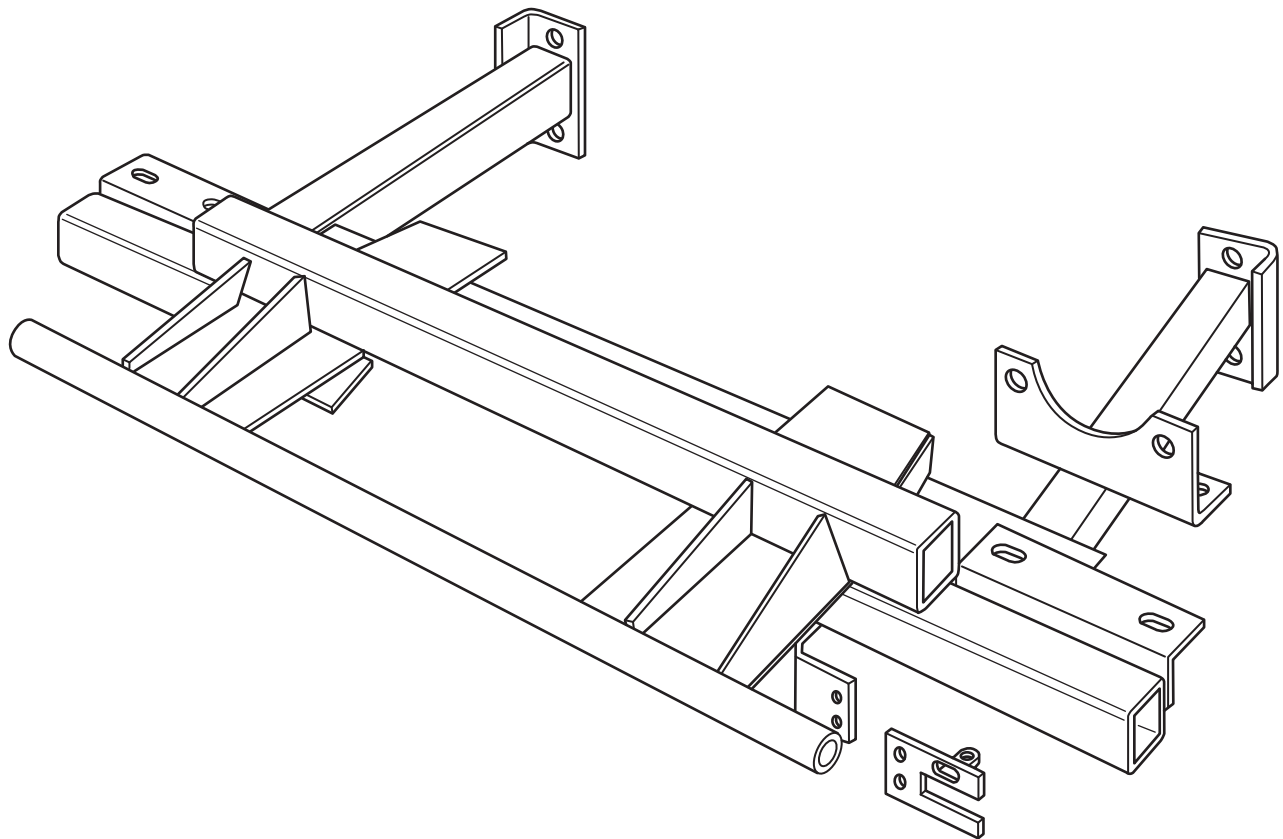

# HOME-PRO<sup>®</sup> 3000

**2005 - Dodge Dakota  
(With Max. GVWR & Max. FGAWR ONLY)**

**Vehicle Mounting Kit: 1FK35**



Curtis Industries Inc. LLC, 111 Higgins St., Worcester, MA 01606 TEL: (800) 343-7676 FAX: (508) 854-3377 For Parts and information visit us at [www.Curtisindustries.net](http://www.Curtisindustries.net)  
Curtis Industries Inc. LLC, reserves the right to change product design or specifications without notice or liability.  
Curtis Snow Plows are protected by the following U.S. Patent Numbers: 6,145,222 and 6,209,231 Licensed under U.S. Patent Number 5,568,694 & Canadian Patent Number 2,137,853.  
Other patents pending.

## 1FK35 Vehicle Mount Kit Parts List

| Item #  | Description  | Qty. |
|---|--|------|
| 1   | Mounting Frame                                     | 1    |
| 2   | Dual Plug Harness Bracket                          | 1    |
| 3   | Bumper Mounting Bracket                            | 2    |
| <b>Hardware Bag Components Included In This Kit</b>                         |  |      |
| 4   | Pipe Spacer  | 4    |
| 5   | 1/2"-13 x 1-1/2" Hex Head Bolt, Gr. 5, Plated      | 4    |
| 6   | 1/2" Flat Washer, Plated                           | 4    |
| 7   | 1/2" Lock Washer, Plated                           | 4    |
| 8   | 1/2"-13 Hex Nut, Plated                            | 4    |
| 9   | 10mm x 1.5mm x 95mm Hex Head Bolt, Gr. 9.8, Plated | 4    |
| 10  | 10mm Flat Washer, Plated                           | 4    |
| 11  | 10mm Lock Washer, High Strength, Plated            | 4    |
| <b>Hardware Components Included In Plow Light Harness Kit P/N: 1TBP134B</b> |  |      |
| 2   | Dual Plug Harness Bracket                          | 1    |
| -   | 10-32 x 3/4" Hex Head Screw, Plated                | 2    |
| -   | 10-32 Nylock Lock Nut, Plated                      | 2    |
| -   | 8-32 x 1" Hex Head Screw, Plated                   | 1    |
| -   | 8-32 Nylock Lock Nut, Plated                       | 1    |
| -   | #8 Nylon Flat Washer, 3/4" O.D.                    | 1    |
| -   | #8 Flat Washer, SAE, Plated                        | 1    |



### WARNING

It is highly recommended that front "helper springs", "airshocks", or other similar devices be installed onto this vehicle to prevent the front suspension from "bottoming out" while carrying a snow plow.

Vehicle must be properly "ballasted" by placing ballast weight behind the centerline of Rear Axle so that no more than 62% of the total weight of the Vehicle, Snow Plow, Driver, Ballast weight, (and any cargo) is placed on the Front Axle while at the same time not exceeding the Gross Vehicle Weight Rating and Front or Rear Gross Axle Weight Ratings.

# 1FK35 Mounting

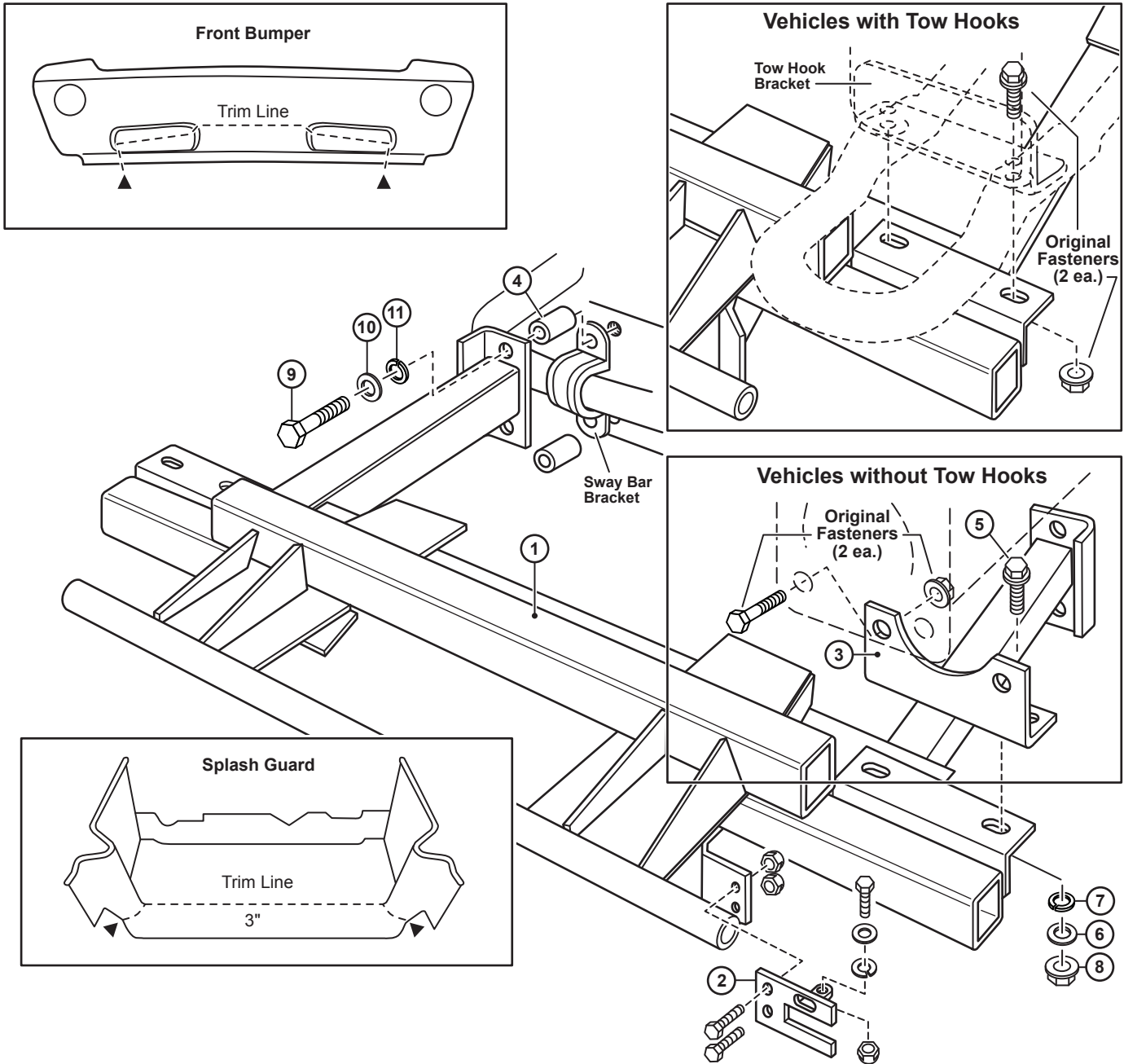

**Curtis Industries, LLC. reserves the right to change product design or specifications without notice or liability. Curtis Snow Plows and Truck equipment should only be used on vehicles equipped with the manufacturer's Snow Plow preparation package. Snow Plowing without the original snow plow preparation package may damage your vehicle and the added weight of the equipment may impair the operation and control of the vehicle.**

# 1FK35: 2005 - Dodge Dakota

## Mounting Kit Installation Instructions

### 1. VEHICLE PREPARATION

- (1a.) Disconnect the fog light wiring if the vehicle is equipped with them. Remove the vehicle front bumper, grill, and headlight assemblies. If the vehicle is equipped with tow hooks, remove the front two 12mm bolts holding each hook to it's bracket. (Do not remove the remaining bolt from the tow hooks.)
- (1b.) Remove and discard the two 10mm bolts holding each sway bar bracket to the front suspension cross member. Leave the sway bar in place against the front suspension cross member. Save all the 12mm original equipment fasteners, they will be reused to attach the bumper and plow mounting frame.
- (1c.) Cut out and discard a section of the plastic lower bumper and air dam 38" wide and up to the bottom edge of the inner steel bumper frame work. Cut out and discard a 3" wide section from the front edge of the black plastic box between the bottom of the radiator and the back of the bumper.



**NOTE**

All fasteners should remain loose or "finger tight" until all components have been attached to Vehicle or installation instructions specify tightening.



**NOTE**

This vehicle may or may not have tow hooks depending on model and/or option packages.

### 2. MOUNTING FRAME

- (2a.) **VEHICLES WITHOUT TOW HOOKS:** Reinstall the front bumper back onto the vehicle. Fasten loosely with the top original equipment nuts only. Place the holes in the vertical flange of a bumper mounting bracket (3) onto the bumper mounting studs on the back side of each frame rail bracket. Fasten using the original equipment nuts. Lift the mounting frame (1) up under the front of the vehicle with the slotted holes in the front brackets lined up with the holes in each bumper mounting bracket (3). Fasten loosely using 1/2"-13 x 1-1/2" bolts (5), 1/2" flat washers (6), 1/2" lock washers (7), and 1/2"-13 nuts (8).
- (2b.) **VEHICLES WITH TOW HOOKS:** Reinstall the front bumper back onto the vehicle. Fasten loosely with the original equipment nuts. Lift the mounting frame (1) up under the the front of the vehicle with the slotted holes in the front brackets lined up with the holes in the bottom surface of the tow hooks. Fasten loosely using the original equipment 12mm fasteners removed previously.
- (2c.) **ALL VEHICLES:** Place pipe spacers (4) between the back side of the mounting frame (1) rear mounting brackets and the front side of the sway bar brackets lined up with the holes in the brackets and the threaded holes in the front suspension cross member. Fasten using 10mm x 1.5mm x 95mm bolts (9), 10mm flat washers (10), and 10mm lock washers (11) through the mounting frame (1) rear mounting brackets, through the pipe spacers (4), through the sway bar brackets, threaded into the front suspension cross member. Align and center the vehicle bumper and plow mounting frame (1) then fully tighten all original equipment and any additional installed fasteners. Reconnect the fog light wiring if the vehicle is equipped with them.

- (2d.) Reinstall the vehicle grill and head light assemblies after the vehicle side plow wiring harness and plow head light wiring adapters are completely connected.

### 3. FINAL ASSEMBLY AND INSPECTION

Inspect the mounting attachment bolts to be certain that they are all in place and that they are all tight.

### 4. OPTIONAL PLUG MOUNT BRACKET INSTALL



**NOTE**

Install the Plug Mount Bracket if the harness will be mounted on the frame kit, otherwise, the harness may be routed through the grill, bumper, etc.

Using (2) 10-32 x 3/4" hex bolts and nylon locknuts, fasten the Plug Mount Bracket to the Plug Mount Bracket Mounting Tab located on the drivers side of the frame kit receiver. The included 8-32 hardware is used for mounting the hi-amp battery leads to the Plug Mount Bracket, if used.

