

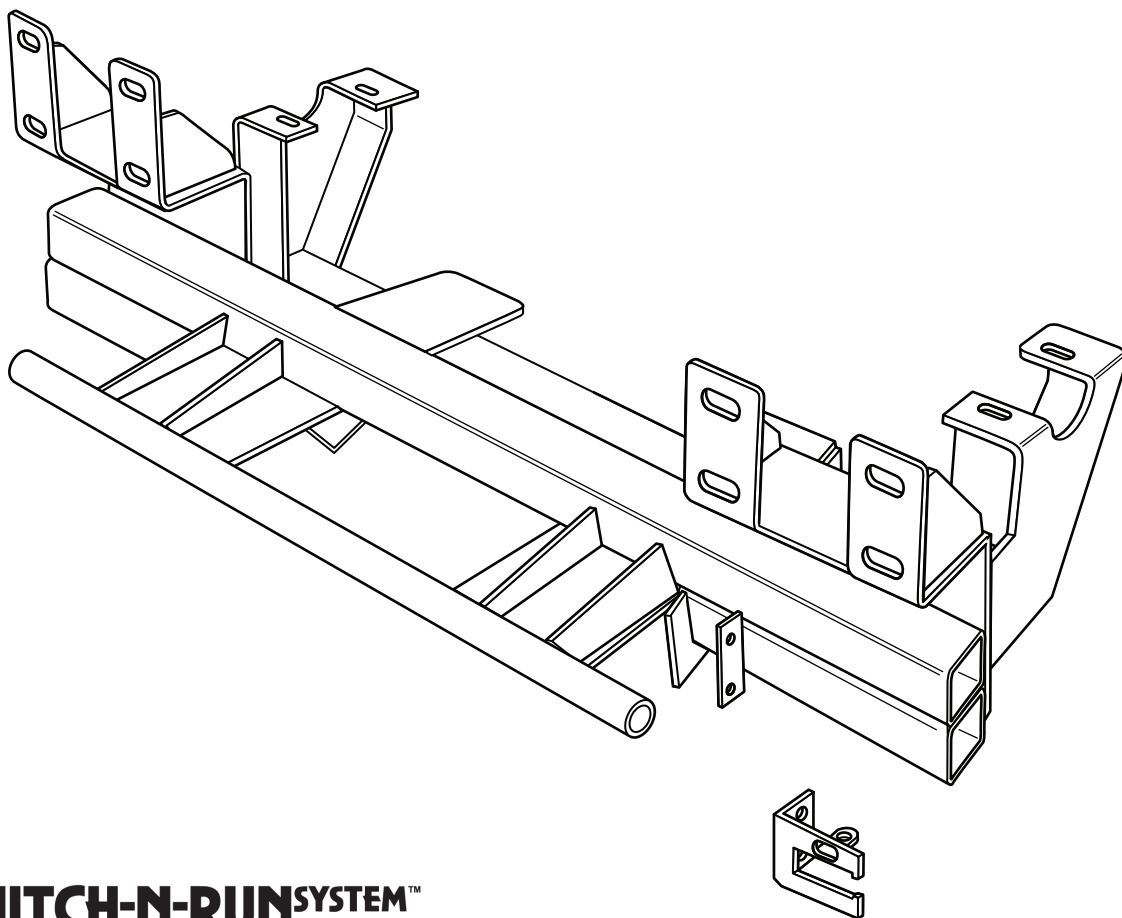

HOME-PRO[®] 3000

**2007 - Jeep Wrangler 4x4
(With Max. FGAWR. & GVWR. ONLY)**

Vehicle Mounting Kit: 1FK41



Curtis Industries Inc. LLC, 111 Higgins St., Worcester, MA 01606 TEL: (800) 343-7676 FAX: (508) 854-3377 For Parts and information visit us at www.Curtisindustries.net
Curtis Industries Inc. LLC, reserves the right to change product design or specifications without notice or liability.
Curtis Snow Plows are protected by the following U.S. Patent Numbers: 6,145,222 and 6,209,231 Licensed under U.S. Patent Number 5,568,694 & Canadian Patent Number 2,137,853.
Other patents pending.

1FK41 Vehicle Mount Kit Parts List

Item #	Description	Qty.
1	Mounting Frame	1
2	3/4" O.D. x 1/2" I.D. x 7/8" Long Pipe Spacers	4
Hardware Bag Components Included In This Kit		
4	10mm Flat Washer, Plated	4
5	12mm x 35mm x 1.50 Bolt Grade 8, Plated	8
6	12mm Flat Washer, Plated	16
7	12mm Lock Washer, Plated	8
8	12mm x 1.50 Nut, Plated	8
9	10mm x 50mm x 1.50 Gr. 8 Bolt, Plated	4
10	10mm Lock Washer, Plated	4
Hardware Components Included In Plow Light Harness Kit		
3	Dual Plug Harness Bracket	1
-	10-32 x 3/4" Hex Head Screw, Plated	2
-	10-32 Nylock Lock Nut, Plated	2
-	8-32 x 1" Hex Head Screw, Plated	1
-	8-32 Nylock Lock Nut, Plated	1
-	#8 Nylon Flat Washer, 3/4" O.D.	1
-	#8 Flat Washer, SAE, Plated	1



WARNING

It is highly recommended that front "helper springs", "airshocks", or other similar devices be installed onto this vehicle to prevent the front suspension from "bottoming out" while carrying a snow plow.

Vehicle must be properly "ballasted" by placing ballast weight behind the centerline of Rear Axle so that no more than 62% of the total weight of the Vehicle, Snow Plow, Driver, Ballast weight, (and any cargo) is placed on the Front Axle while at the same time not exceeding the Gross Vehicle Weight Rating and Front or Rear Gross Axle Weight Ratings.

1FK41 Mounting

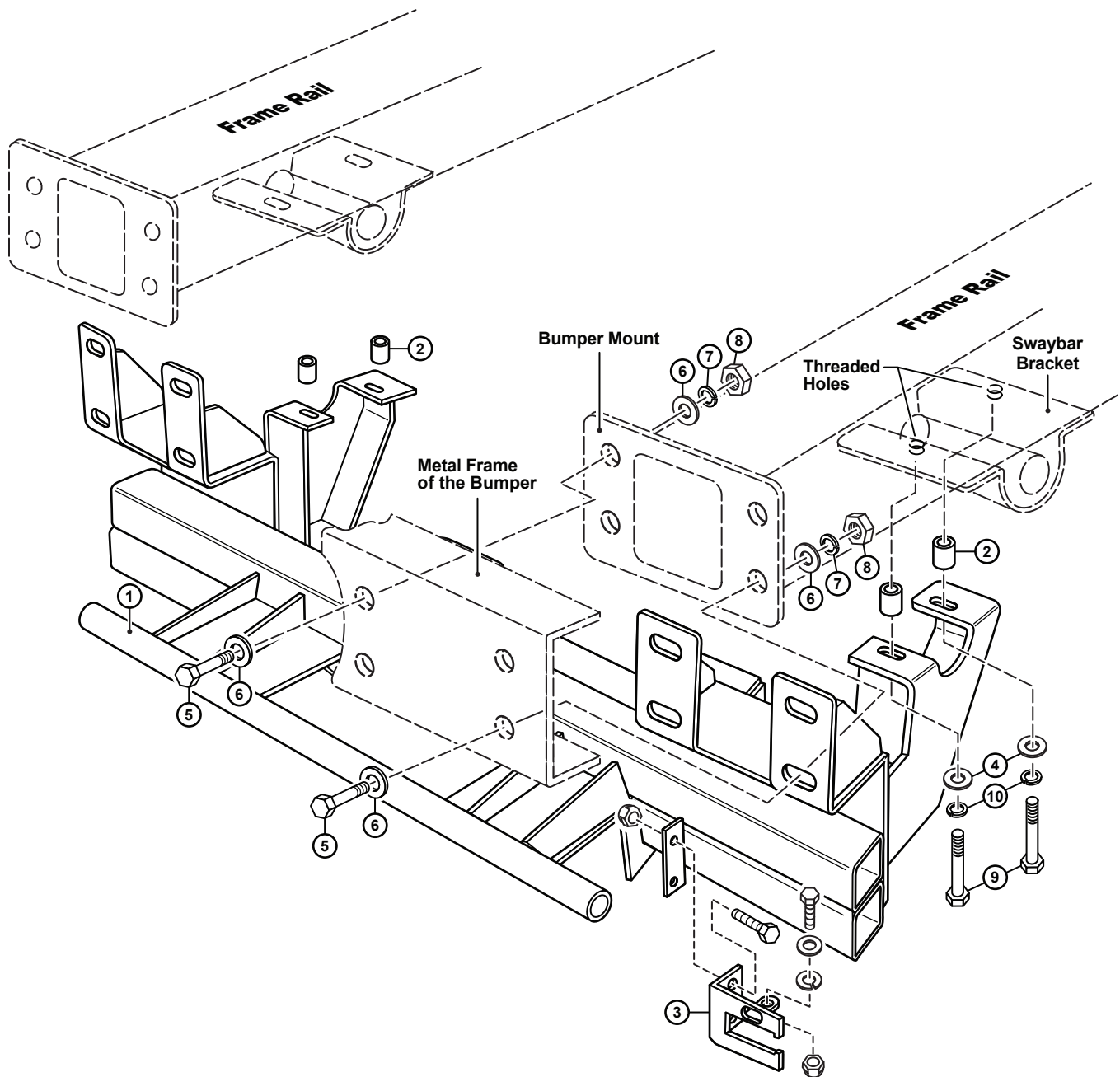

Curtis Industries, LLC. reserves the right to change product design or specifications without notice or liability. Curtis Snow Plows and Truck equipment should only be used on vehicles equipped with the manufacturer's Snow Plow preparation package. Snow Plowing without the original snow plow preparation package may damage your vehicle and the added weight of the equipment may impair the operation and control of the vehicle.

1FK41: 2007 - Jeep Wrangler 4x4

Mounting Kit Installation Instructions

1. VEHICLE PREPARATION

- (1a.) Remove the vehicle front bumper assembly by removing the eight 12mm. nuts located behind the front bumper mounts at the end of the frame rails.
- (1b.) Remove the plastic splash shield. Remove the plastic bumper cover by removing the four 10mm bolts holding it to the metal frame of the bumper.
- (1c.) Remove the four 10mm. bolts holding the sway bar brackets to the bottom of the frame rails.



NOTE

All fasteners should remain loose or "finger tight" until all components have been attached to Vehicle or installation instructions specify tightening.

2. MOUNTING FRAME

- (2a.) Lift the mounting frame (1) up so the front mounting holes are behind the bumper mounts at the end of the frame rails and lined up with the eight bumper mounting holes. The four rear mounting holes should also be lined up with the sway bar bracket holes.
- (2b.) Place the four pipe spacers (2) over each of the rear mounting holes lined up with the sway bar bracket holes in the bottom of the frame rails. Fasten with four 10mm x 50mm x 1.50 bolts (9), flat washers (4), and lock washers (10).
- (2c.) Re-install the metal frame of the front bumper using 12mm x 35mm x 1.50 bolts (5), flat washers (6), and lock washers (7), and 12mm nuts (8). Place a 12mm. flat washer (6) over the end of each bolt before placing them through the metal frame of the bumper.

3. TIGHTENING

- (3a.) Tighten the four 10mm x 50mm rear mounting bolts (9). Tighten the eight 12mm x 35mm x 1.50 bolts (5), and nuts (8) holding the metal frame of the bumper to the bumper brackets.
- (3b.) Re-install the outer plastic cover to the metal frame of the bumper using the original 10mm bolts.

4. FINAL ADJUSTMENT AND INSPECTION

Inspect the mounting attachment bolts to be certain that they are all in place and that they are all tight.

5. OPTIONAL PLUG MOUNT BRACKET INSTALL



NOTE

Install the Plug Mount Bracket if the harness will be mounted on the frame kit, otherwise, the harness may be routed through the grill, bumper, etc.

Using (2) 10-32 x 3/4" hex bolts and nylon locknuts, fasten the Plug Mount Bracket to the Plug Mount Bracket Mounting Tab located on the drivers side of the frame kit receiver. The included 8-32 hardware is used for mounting the hi-amp battery leads to the Plug Mount Bracket, if used.

