

CHEV/GMC 6.2L
DIESEL
W-W/O AC

1984-1987

PECULIAR HYDRAULICS
BELT DRIVE, SLC
UNDERHOOD VALVE

HPS4542
REV C

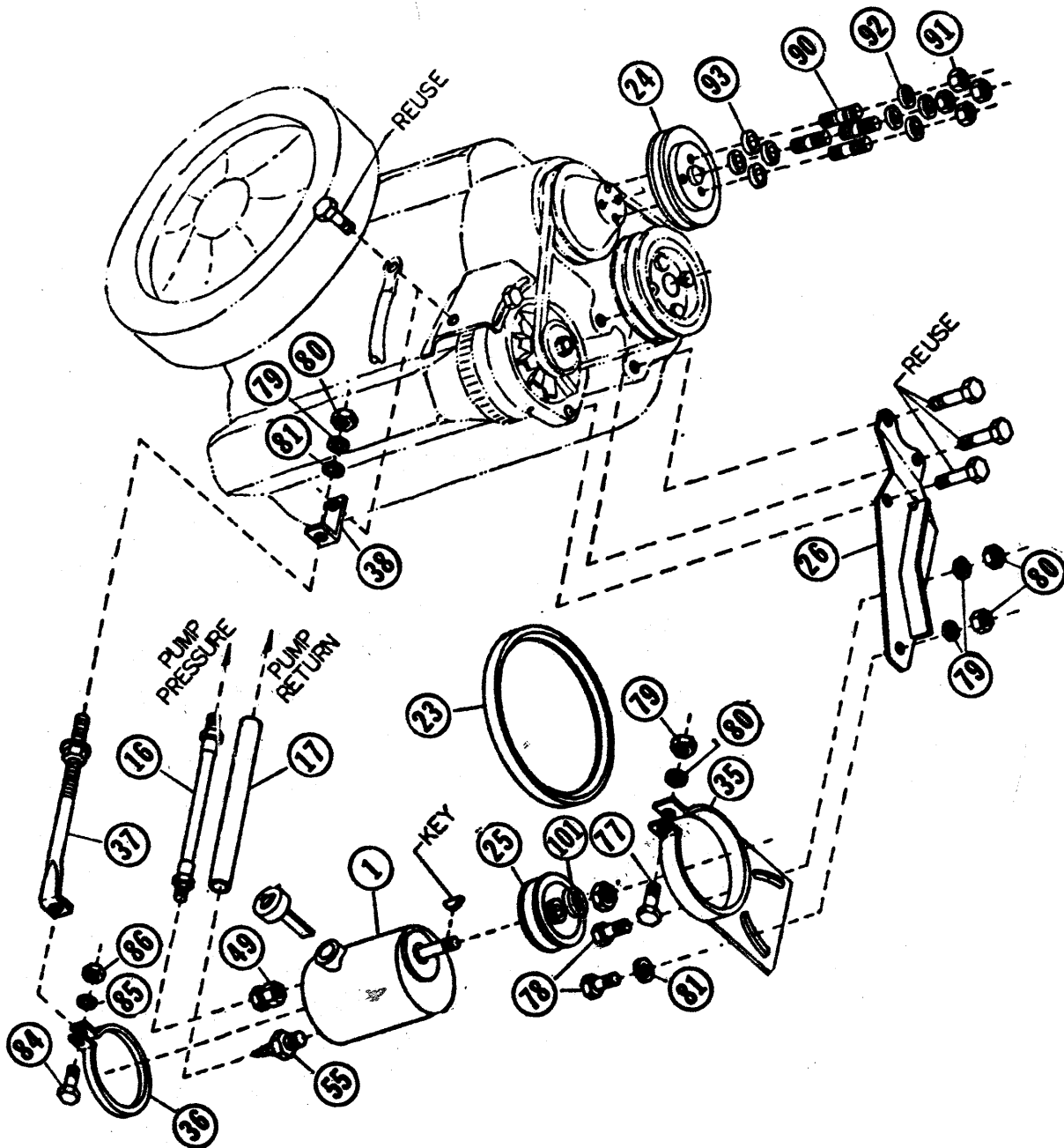

6297

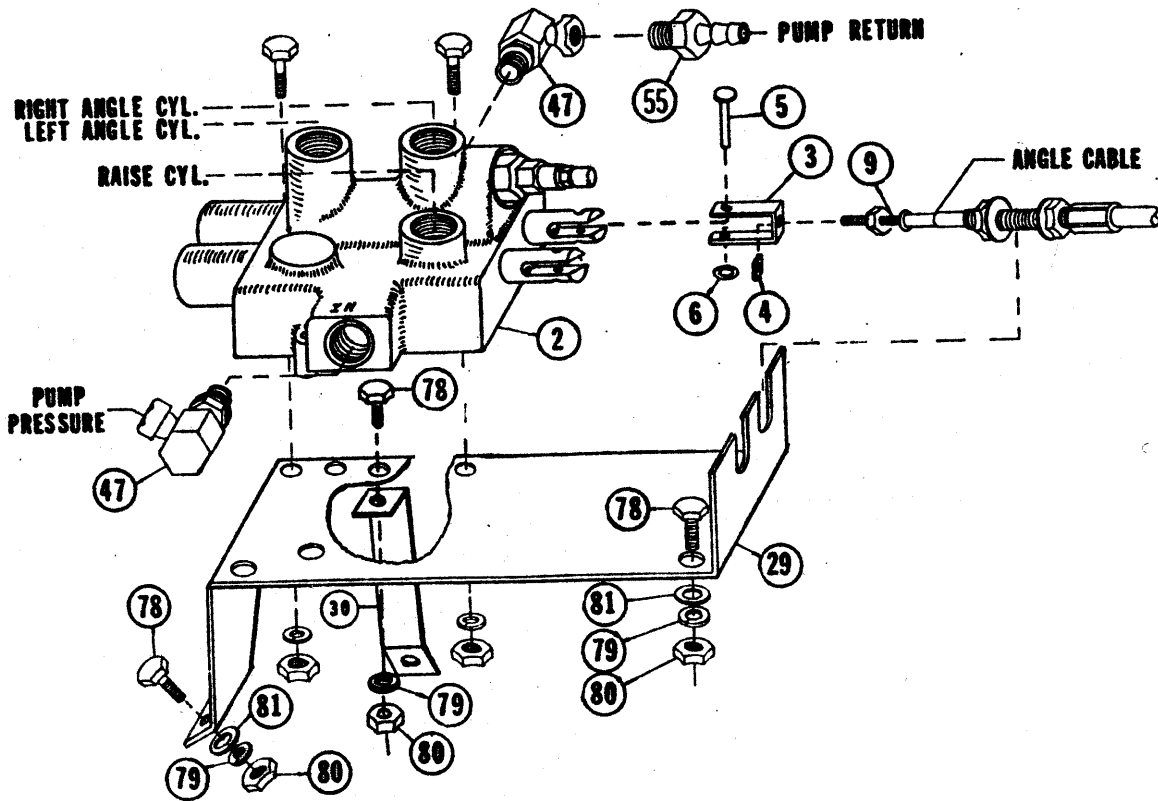
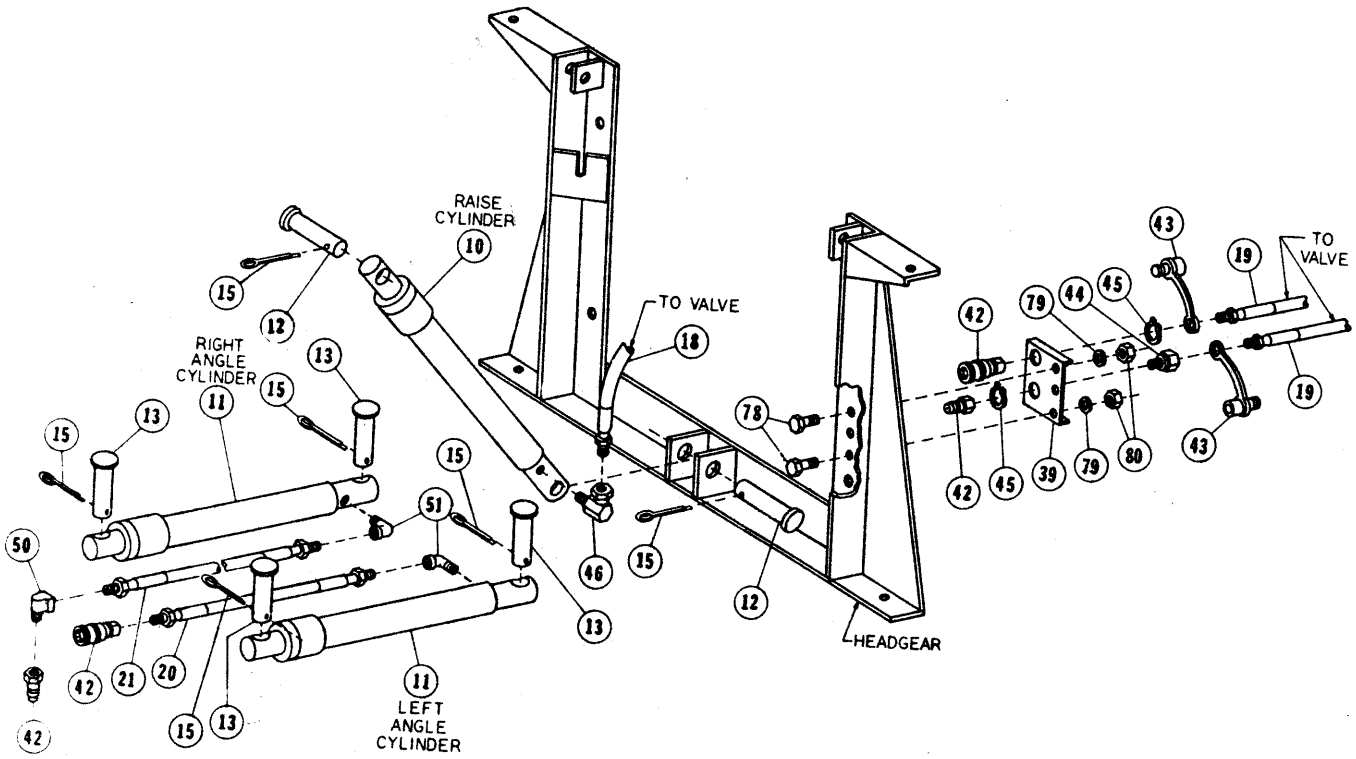

HYDRAULIC PARTS LIST

HPS4542
REV C

REF#	QTY IN KIT A4468-40 HPS4542		PART#	DESCRIPTION * PART OF 6916 BOLT BAG
1	1		A2311	PUMP TANK ASSEMBLY
2	1		A4466	CONTROL VALVE ASSEMBLY
3	2		4483	CLEVIS
4	2		4494	10-32 SQUARE NUT
5	2		4491	CLEVIS PIN - 3/16 X 1
6	2		4493	3/16 PUSH NUT
7	1		8764	FILTER KIT (AT END OF INSTRUCT.)
8		1	4419	SINGLE LEVER CONTROL HEAD
9		2	4488	40" CONTROL CABLE, SLC
10	1		A318	10" LIFT CYLINDER ASSEMBLY
11	2		A3660	12" ANGLE CYLINDER ASSEMBLY
12	2		6814	CLEVIS PIN - 1 X 3-5/16
13	4		6816	ANCHOR PIN - 1 X 4
14				
15	6		90601	1/4 X 1-1/2 COTTER PIN
16		1	2516	72" H.P. HOSE, 1/4P TO 3/8P
17		1	2515	72" L.P. HOSE
18		1	1665	60" H.P. HOSE, 9/16 O-RING TO 1/4P
19		2	166	54" H.P. HOSE, 9/16 O-RING TO 1/4P
20		1	376	32" H.P. HOSE, 1/4P TO 1/4P
21		1	4424	36" H.P. HOSE, 1/4P TO 1/4P
22				
23		1	400	FAN BELT 4L 480
24		1	5933	DRIVE SHEAVE
25		1	7909	PUMP SHEAVE
26		1	5581	PUMP BRACKET
27				
28				
29		1	5780	VALVE PLATE
30		1	5781	VALVE PLATE BRACE
31				
32				
33				
34				
35		1	5495	SADDLE BRACKET
36	1		2036	REAR TANK STRAP
37	1		2116	UNIVERSAL BRACE ROD
38		1	2115	* UNIVERSAL BRACE TAB
39		1	4467	DISCONNECT MOUNTING PLATE
40				
41				
42	2		A1587	DISCONNECT ASSEMBLY
43	2		1588	DUST PLUG
44		1	4486	* BULKHEAD ADAPTER
45		2	4485	* 7/8" SNAP RING
46	1		319	1/4" X 90 SWIVEL ADAPTER
47	2		2315	9/16 O.R. TO 3/8P X 90 SWL.ADPT.
48				
49		1	1659	* ADAPTER UNION, 1/4 F.P.T. BOTH ENDS

REF#	QTY IN KIT A4468-40 HPS4542		PART#	DESCRIPTION * PART OF 6916 BOLT BAG
50		1	765	* 1/4" BRASS BAR STREET ELL
51	2		2780	1/4" BRASS BAR STREET ELL (FORGED)
52				
53				
54				
55	2		1658	QUILL
56				
57				
58				
59				
60				
61				
62				
63				
64				
65				
66				
67				
68				
69				
70				
71				
72		1	5704	SAFETY DECAL
73	2		3042	GROMMET
74	1		4477	SPLIT HOSE GROMMET
75	3		3666	TIE WRAPS 3/16 X 8
76				
77	1		90054	5/16 X 1-1/2 (NC) GR. 5 CAPSCREW
78	4	3	90042	* 5/16 X 1 (NC) GR.5 CAPSCREW
79	6	3	90360	* 5/16 LOCKWASHER
80	7	3	90332	* 5/16 (NC) NUT
81	4	3	90313	* 5/16 FLATWASHER
82				
83				
84	1		90614	1/4 X 1-1/4 (NC) GR.5 CAPSCREW
85	1		90359	1/4 LOCKWASHER
86	1		90330	1/4 (NC) NUT
87				
88				
89				
90		4	5939	* M8 X 50 STUD GR. 10.9
91		4	90423	* M8 X 1.25 NUTS
92		4	90428	* M8 LOCKWASHERS
93		4	5940	* 7/16" O.D. TUBE SPACER
94				
95				
93				
94				
101		1	90319	* 1/2 FLATWASHER

DIAMETER- THREADS PER INCH	GRADE		
	G2	G3	G8
1/4 - 20	6	9	13
5/16 - 18	11	18	28
3/8 - 16	19	31	46
7/16 - 14	30	50	75
1/2 - 13	45	75	115
9/16 - 12	66	110	165
5/8 - 11	93	150	225
9/16 - 12	150	250	370
7/8 - 9	150	378	591
1 - 8	220	583	893

1. CYLINDER AND CYLINDER HOSE ASSEMBLY

- A.** USING BENCH VISE TO HOLD LIFT CYLINDER (10), REMOVE CLOSURE FROM PORT. SCREW 90 DEGREE SWIVEL ADAPTER (46) INTO PORT. PLACE LIFT CYLINDER WITH INSTALLED ADAPTER BETWEEN EARS ON UNDERSIDE OF LIFT ARM AND LOWER HEADGEAR EARS. ATTACH CYLINDER TO EARS USING CLEVIS PINS (12) AND COTTER PINS (15).
- B.** USING BENCH VISE TO HOLD 32" H.P. HOSE (20), INSTALL FEMALE HALF OF HOSE DISCONNECT ASSEMBLY (42) DIRECTLY TO HOSE. THEN, HOLDING 36" H.P. HOSE (21), INSTALL BRASS BAR STREET ELL (50) AND MALE HALF OF HOSE DISCONNECT ASSEMBLY (42) ON THE SAME HOSE END.
- C.** USING BENCH VISE TO HOLD ANGLE CYLINDERS (11), REMOVE CLOSURES FROM PORTS AND SCREW BRASS FORGED STREET ELLS (51) INTO PORTS SO THAT ELLS ARE PARALLEL WITH CYLINDER AND POINT TOWARD LIVE END. INSTALL 32" H.P. HOSE WITH FEMALE DISCONNECT HALF TO DRIVE SIDE ANGLE CYLINDER STREET ELL. INSTALL OTHER H.P. HOSE WITH MALE DISCONNECT HALF TO PASSENGER SIDE ANGLE CYLINDER STREET ELLS. INSTALL ANGLE CYLINDERS TO "A" FRAME ON THEIR RESPECTIVE SIDES SO THAT ELLS ARE BETWEEN CYLINDERS AND "A" FRAME. SECURE CYLINDERS WITH ANCHOR PINS (13) AT PORT END AND RAM END. SECURE ANCHOR PINS WITH COTTER PINS (15).

2. CONTROL HEAD AND CONTROL CABLES

NOTE: DASH BRACKET, HARDWARE, DRILLING GUIDE AND MOUNTING INSTRUCTIONS WILL BE FOUND IN PECULIAR ATTACHING BOX.

- A.** DRILL THREE 5/8" HOLES IN FIREWALL FOR CONTROL CABLES AND WIRING HARNESS USING DRILLING GUIDE AS A REFERENCE ONLY. BE SURE BOTH SIDES OF FIREWALL ARE CLEAR OF OBSTRUCTIONS BEFORE DRILLING. CUT AWAY PADDING FROM AROUND THE HOLES INSIDE OF THE CAB TO ALLOW INSTALLATION OF RUBBER GROMMETS IN STEP C. DRILL A 1/2" HOLE IN THE UNDERSIDE OF DASH AS SHOWN IN DASH ILLUSTRATION.
- B.** INSTALL DASH BRACKET AS PER DASH BRACKET INSTRUCTIONS.
- C.** LOOSEN JAM NUTS ON CONTROL HEAD END OF CABLES (9) AND INSTALL INTO SLOTS IN CONTROL HEAD (8). (RAISE CABLE CENTERS IN BEGINNING OF LOWER SLOT). SNAP CABLE ENDS ONTO BALL STUDS AND TIGHTEN JAM NUTS TO SECURE CABLES TO CONTROL HEAD. REMOVE THE NUTS AND WASHERS FROM THE VALVE END OF THE CABLES. ROUTE THE CABLES OUT THROUGH THE FIREWALL UP TO THE TOP OF THE DRIVER SIDE FENDERWELL. ATTACH CONTROL HEAD TO DASH BRACKET AS PER DASH BRACKET INSTRUCTIONS. INSTALL RUBBER GROMMETS (73) AROUND CABLES WHERE THEY PASS THROUGH FIREWALL.

3. VALVE AND VALVE PLATE

- A.** USING BENCH VISE TO HOLD CONTROL VALVE ASSEMBLY (2) REMOVE CLOSURES FROM VALVE PORTS. SCREW 90 DEGREE SWIVEL ADAPTER UNIONS (47) INTO "IN" AND "OUT" PORTS. SCREW QUILL (55) INTO INSTALLED ADAPTER IN "OUT" PORT. NOTE: VALVE FITTINGS ARE INSTALLED AS DESCRIBED TO INSURE PROPER INSTALLATION. FIRST INDICATION OF INCORRECT INSTALLATION IS FAILURE OF PLOW TO LIFT ALTHOUGH PLOW WILL ANGLE.

B. MOUNT VALVE TO VALVE PLATE (29) USING TWO 1/4 X 1-1/4 CAPSCREWS, LOCKWASHERS AND NUTS FROM VALVE BAG. CONNECT CONTROL CABLES TO VALVE PLATE BEFORE FASTENING VALVE PLATE TO VEHICLE. BEGIN BY REINSTALLING JAM NUTS AND WASHERS ON CABLES. PLACE CONTROL CABLES IN RESPECTIVE SLOTS OF VALVE PLATE BULKHEAD WITH ONE NUT AND ONE WASHER ON EACH SIDE OF BULKHEAD. CENTER CABLES IN SLOTS SO THAT THEY ARE EXACTLY IN LINE WITH VALVE SPOOL CENTERS. ATTACH CABLE CLEVIS (3) TO CABLES USING SQUARE NUTS (4). SLIP CABLE CLEVISES OVER SPOOLS. INSTALL CLEVIS PIN (5) THROUGH CLEVIS AND SPOOL AND SECURE WITH PUSHNUT (6) ON CLEVIS PIN. TEMPORARILY ADJUST CABLES SO THAT CONTROL LEVER IS SOMEWHERE NEAR CENTERED IN CONTROL HEAD.

NOTE: ON VEHICLES EQUIPPED WITH CRUISE CONTROL IT MAY BE NECESSARY TO RELOCATE CONTROL UNIT, ASSOCIATED CABLES AND WIRES BACK TOWARD FIREWALL TO ALLOW ENOUGH SPACE ON FENDERWELL TO MOUNT VALVE PLATE.

C. LOCATE VALVE PLATE, WITH VALVE AND CABLES ATTACHED, ON TOP OF DRIVER'S SIDE INNER FENDERWELL SO THAT VALVE IS NEAR LEVEL AND CABLES RUN IN AS SMOOTH A PATH AS POSSIBLE. USING THE HOLES IN EACH END OF VALVE PLATE AS A GUIDE, DRILL TWO 11/32" HOLES THROUGH THE FENDERWELL. FASTEN THE VALVE PLATE TO THE FENDERWELL WITH TWO 5/16 X 1 CAPSCREWS (78), FLATWASHERS (81), LOCKWASHERS (79) AND NUTS (80). ATTACH 90 DEGREE BENT END OF VALVE PLATE BRACE (30) TO VALVE PLATE AS SHOWN IN ILLUSTRATION WITH A 5/16 X 1 CAPSCREW (78), LOCKWASHER (79) AND NUT (80). USING HOLE IN OTHER END OF BRACE AS A GUIDE, DRILL ANOTHER 11/32" HOLE THROUGH THE FENDERWELL AND FASTEN WITH A 5/16 X 1 CAPSCREW (78), FLATWASHER (81), LOCKWASHER (79) AND NUT (80).

D. WITH VALVE PLATE FASTENED TO INNER FENDER, RE-ADJUST CONTROL CABLES SO THAT CONTROL HEAD LEVER IS CENTERED BETWEEN BOTH ANGLE AND RAISE/LOWER POSITIONS. IF CABLE CLEVIS DOES NOT ALLOW ENOUGH ADJUSTMENT, REPOSITION CABLE AT VALVE PLATE BULKHEAD. AFTER CHECKING TO SEE THAT THE VALVE SPOOLS ARE IN THE CENTERED POSITION, TIGHTEN CABLE CLEVIS NUTS.

CAUTION: VALVE SPOOLS MUST BE FREE AND SELF CENTERING WHEN CABLES AND CONTROL HEAD ARE ATTACHED. FAILURE TO CENTER SPOOLS WILL RESTRICT FLUID FLOW THROUGH VALVE. THIS MAY CAUSE HYDRAULIC FLUID TO OVERHEAT RESULTING IN PUMP DAMAGE AND OR HYDRAULIC HOSE FAILURE. HOSE FAILURES CAN CAUSE ENGINE FIRES.

WHEN ADJUSTED, THE CONTROL LEVER MUST BE IN THE NEUTRAL POSITION TO ALLOW ENOUGH SPOOL TRAVEL EACH WAY FOR PROPER VALVE ACTUATION.

4. DRIVE SHEAVE INSTALLATION

A. LOOSEN & REMOVE ALL BELTS. REMOVE CLUTCH FAN & PULLEYS FROM WATER PUMP SHAFT FLANGE. REMOVE & DISCARD STUDS FROM WATER PUMP SHAFT FLANGE.
1984-85 VEHICLES: INSTALL THE FOUR LONGER 8MM STUDS (90) TO HOLES IN WATER PUMP SHAFT FLANGE THAT ORIGINAL STUDS WERE REMOVED FROM. INSTALL ONE TUBE SPACER (93) OVER EACH STUD. PLACE VEHICLE PULLEYS, DRIVE SHEAVE (24) AND FAN ON OVER STUDS AND SPACERS. SECURE WITH FOUR 8MM LOCKWASHERS (92) AND 8MM NUTS (91) TORQUED TO 18 FT. LBS.

5. PUMP TANK AND PUMP BRACKET

A. REMOVE THE LOWER ALTERNATOR BRACKET FROM THE ENGINE BY REMOVING THE ALTERNATOR PIVOT BOLT AND THE TWO NUTS FROM THE FRONT OF THE ENGINE. DISCARD THE BRACKET BUT SAVE ALL THE BOLTS AND NUTS.

B. INSTALL THE PUMP BRACKET (26) TO THE ENGINE IN THE SAME LOCATION AS THE ALTERNATOR BRACKET. USE THE TWO ORIGINAL NUTS TO HOLD IT IN PLACE. ALIGN THE LOWER HOLE OF THE ALTERNATOR WITH THE TOP CENTER HOLE OF THE PUMP BRACKET AND REINSTALL THE ALTERNATOR PIVOT BOLT.

C. HOLDING PUMP TANK (1) IN BENCH VISE, SCREW 1/4" SWIVEL ADAPTER UNION (49) ONTO TO PRESSURE PORT AND SCREW QUILL (55) INTO RETURN PORT. INSTALL PUMP SHEAVE (25) ON TO PUMP SHAFT USING LOCKNUT SUPPLIED WITH PUMP. WHEN INSTALLING LOCKNUT MAKE SURE THAT THE LOCKNUT TIGHTENS AGAINST THE PUMP SHEAVE, AND NOT AGAINST THE PUMP SHAFT SHOULDER. AN OPTIONAL 1/2 PLAIN WASHER (101) SHOULD BE INSTALLED ONLY IF THE LOCKNUT TIGHTENS AGAINST THE PUMP SHAFT SHOULDER AND NOT THE SHEAVE.

CAUTION: TO AVOID DAMAGE TO THE PUMP SHAFT, MAKE SURE THAT THE 1/2 FLATWASHER FITS ON OVER THE SHAFT SHOULDER BEFORE TIGHTENING LOCKNUT.

REMOVE PUMP FROM VISE & INSTALL SADDLE BRACKET (35) ON OVER FRONT OF PUMP. SECURE WITH A 5/16 X 1-1/2 GR.5 CAPSCREW (77), LOCKWASHER (79) AND (80). ATTACH SADDLE BRACKET & PUMP TO PUMP BRACKET USING TWO 5/16 X 1 CAPSCREWS (78), FLATWASHER (81), LOCKWASHERS (79) AND NUTS (80).

D. INSTALL 48" V-BELT (23) ON OVER INSTALLED DRIVE AND PUMP SHEAVES. ALIGN SHEAVES AND TIGHTEN 1-1/2" SADDLE BRACKET FASTENER. ADJUST FOR PROPER TENSION BY PIVOTING SADDLE BRACKET ON TOP BOLT. INSTALL REAR TANK STRAP (36) ON OVER REAR OF PUMP. INSTALL THE UNIVERSAL BRACE TAB (38) BENEATH THE CABLE ON ALTERNATOR ADJUSTMENT BRACKET. INSTALL ONE 5/16 NUT (80) AND 5/16 FLATWASHER (81) ONTO UNIVERSAL BRACE ROD (37). INSTALL BENT END OF BRACE ROD BETWEEN EARS OF TANK STRAP WHILE INSERTING OTHER END THROUGH BRACE TAB. REBEND THE END OF THE BRACE ROD OR TAB AS NEEDED TO ALIGN THE TWO. FASTEN BRACE ROD TO EARS OF TANK STRAP WITH A 1/4 X 1-1/4 CAPSCREW (84), LOCKWASHER (85) AND NUT (86). FASTEN OTHER END OF BRACE ROD TO LIFT HOOK WITH A 5/16 FLATWASHER (81), 5/16 LOCKWASHER (79) AND NUT (80). USE BRACE ROD TO ADJUST ALIGNMENT OF DRIVE AND PUMP SHEAVES. CHECK BELT FOR PROPER TENSION. TIGHTEN POWER STEERING, ALTERNATOR AND ANY OTHER BELTS.

6. HYDRAULIC HOSE INSTALLATION

A. ATTACH 72" H.P. HOSE (16) TO 1/4" SWIVEL ADAPTER ON PUMP TANK AND PUSH 72" L.P. HOSE (17) ONTO QUILL ON PUMP TANK. ROUTE THESE HOSES TO THE CONTROL VALVE.

CAUTION: KEEP HOSES AWAY FROM HOT OR MOVING ENGINE COMPONENTS. FAILURE TO DO SO MAY CAUSE HOSE TO BURST RESULTING IN A POSSIBLE ENGINE FIRE.

PUSH L.P. HOSE ONTO QUILL AND SCREW H.P. HOSE INTO 90 DEGREE SWIVEL ADAPTER. INSTALL 9/16 O-RING END OF 60" H.P. HOSE (18) TO LIFT CYLINDER PORT OF VALVE (SPOOL #1). INSTALL 9/16 O-RING END OF TWO 54"

HOSES (19) TO ANGLE PORTS OF VALVE (SPOOL #2). REMOVE BATTERY TO ALLOW ROOM TO DRILL A 1-7/8" HOLE IN THE RADIATOR WEB NEAR RADIATOR AND TOP OF BATTERY BOX. INSTALL SPLIT HOSE GROMMET (74) AROUND HOLE. ROUTE 60" AND 54" HOSES OUT THROUGH THIS HOLE AND THROUGH GRILL NEAR CENTER OF VEHICLE. ATTACH 60" HOSE TO PREVIOUSLY INSTALLED 90 DEGREE SWIVEL ADAPTER ON LIFT CYLINDER.

INSTALL INLINE OIL FILTER AS PER FILTER KIT (7) INSTRUCTIONS AT THE END OF THIS DOCUMENT.

7. DISCONNECT ASSEMBLY

A. WITH DISCONNECT MOUNTING PLATE (39) HELD IN BENCH VISE, INSTALL DISCONNECT HALVES AS SHOWN IN ILLUSTRATION. BULKHEAD ADAPTER (44) AND MALE DISCONNECT HALF (42) GO IN BOTTOM HOLE. FEMALE DISCONNECT HALF (42) GOES IN TOP HOLE. SECURE BOTH WITH 7/8" SNAP RINGS (45). ATTACH MOUNTING PLATE TO BACK OF DRIVERS SIDE HEADGEAR POST WITH TWO 5/16 X 1 CAPSCREWS (78), LOCKWASHERS (79) AND NUTS (80). INSTALL DUST PLUGS (43) OVER ENDS OF HOSES ROUTED TO FRONT OF VEHICLE IN THE PREVIOUS STEP. CONNECT 54" RIGHT ANGLE HOSE (SPOOL #2, CYL. B) TO BACK OF FEMALE DISCONNECT INSTALLED IN TOP HOLE OF DISCONNECT BRACKET. CONNECT 54" LEFT ANGLE HOSE (SPOOL #2, CYL. A) TO BOTTOM (MALE) DISCONNECT. TIGHTEN BY HOLDING HOSES AND ROTATING THE DISCONNECT HALVES IN THE BRACKET.

8. OPERATIONS

A. CHECK ALL FITTINGS AND FASTENERS FOR TIGHTNESS. SECURE HOSES WITH NYLON TIE WRAPS (75). PLACE SAFETY DECAL (72) ON DASH BESIDE CONTROL HEAD.

B. FILL RESERVOIR WITH TYPE "A" AUTOMATIC TRANSMISSION FLUID. START ENGINE, LIFT AND ANGLE BLADE.

NOTE: IF BLADE ANGLES OPPOSITE FROM CONTROL LEVER POSITION, REVERSE THE TWO H.P. HOSE CONNECTIONS ON THE BACK OF THE DISCONNECT BRACKET.

RAISE FRONT END OF VEHICLE UNTIL PLOW IS CLEAR OF GROUND WITH THE LIFT CYLINDER FULLY RETRACTED. CHECK RESERVOIR OIL LEVEL. ANGLE BLADE (WITH LIFT CYLINDER RETRACTED) TO REMOVE AIR FROM SYSTEM. RECHECK RESERVOIR OIL LEVEL.