

6287

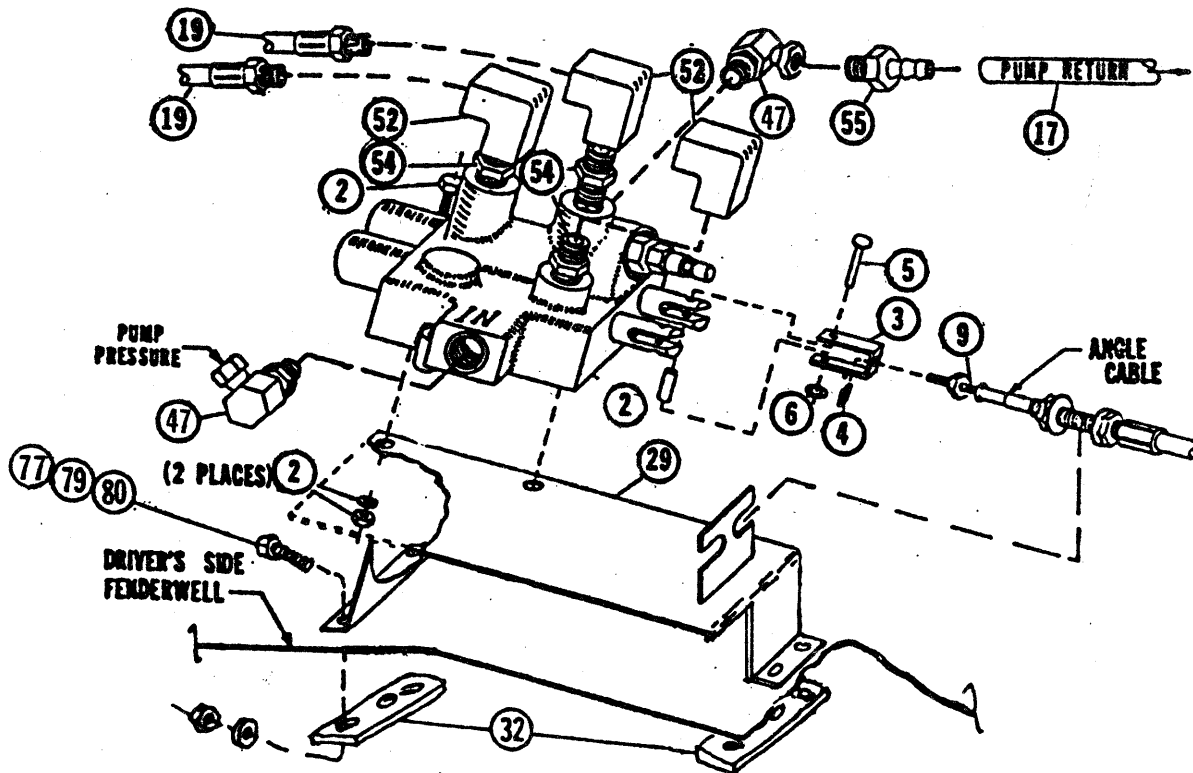

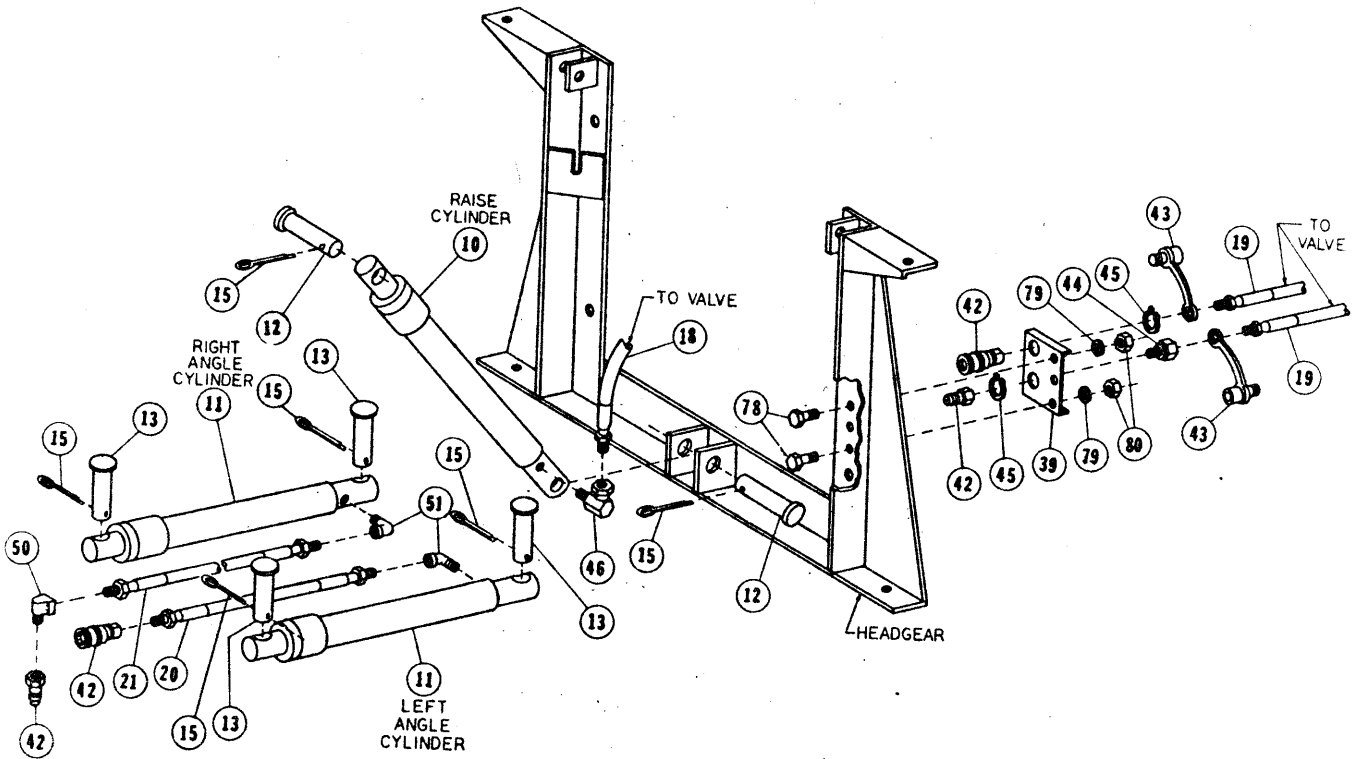

SERIES
G&H

HYDRAULICS PARTS LIST

HPS4585 REV C
A4468

REF#	QTY IN KIT		PART#	DESCRIPTION
	A4468-40	HPS4585		* PART OF 6899 BOLT BAG
1	1		A2311	PUMP TANK ASSEMBLY
2	1		A4466	CONTROL VALVE ASSEMBLY
3	2		4483	CLEVIS
4	2		4494	10-32 SQUARE NUT
5	2		4491	CLEVIS PIN
6	2		4493	3/16 PUSH NUT
7				
8		1	4419	SINGLE LEVER CONTROL HEAD
9		2	4949	30" CONTROL CABLE, SLC
10	1		A318	10" LIFT CYLINDER ASSEMBLY
11	2		A3660	12" ANGLE CYLINDER ASSEMBLY
12	2		6814	CLEVIS PIN
13	4		6816	ANCHOR PIN
14				
15	6		90601	1/4 X 1-1/2 COTTER PIN
16		1	5223	32" H.P. HOSE, 1/4P TO 3/8P
17		1	5653	28" L.P. HOSE
18		1	6066	66" H.P. HOSE, 1/4P TO 1/4P
19		2	5193	54" H.P. HOSE, 1/4P TO 1/4P
20		1	376	32" H.P. HOSE, 1/4P TO 1/4P
21		1	4424	36" H.P. HOSE, 1/4P TO 1/4P
22				
23		1	6067	FAN BELT, 76"
24				
25		1	7909	PUMP SHEAVE
26		1	6068	PUMP BRACKET
27		1	5959	PUMP BRACKET BRACE
28				
29		1	5178	VALVE PLATE
30				
31				
32		2	6031	BACKING PLATE
33		1	6059	CANISTER BRACKET
34				
35		1	5495	SADDLE BRACKET, UNIVERSAL H.D.
36	1		2036	REAR TANK STRAP
37	1		2116	UNIVERSAL BRACE ROD
38		1	6060	* BRACE TAB
39		1	4467	DISCONNECT MOUNTING PLATE
40				
41				
42	2		A1587	DISCONNECT ASSEMBLY
43	2		1588	DUST PLUG
44		1	4486	* BULKHEAD ADAPTER
45		2	4485	* 7/8" SNAP RING
46	1		319	1/4" X 90 SWIVEL ADAPTER
47	2		2315	9/16 O.R. TO 3/8P X 90 SWL.ADPT.
48				
49		1	1659	* ADAPTER UNION

REF#	QTY IN KIT A4468-40 HPS4585		PART#	DESCRIPTION * PART OF 6899 BOLT BAG
50		1	* 765	1/4" BRASS BAR STREET ELL
51	2		2780	1/4" BRASS BAR STREET ELL (FORGED)
52		3	* 2318	1/4" BRASS BAR ELL
53				
54		3	* 3058	1/4 P TO 9/16 O.R. ST.ADPT.
55	2		1658	QUILL
56				
57				
58				
59				
60				
61				
62				
63				
64				
65				
66				
67				
68				
69				
70				
71				
72		1	5704	SAFETY DECAL
73	2		3042	GROMMET
74	1		4477	SPLIT HOSE GROMMET
75	3		3666	TIE WRAPS
76				
77	1	4	90054	5/16 X 1-1/2 (NC) GR. 5 CAPSCREW
78	4		90042	5/16 X 1 (NC) CAPSCREW
79	6	5	* 90360	5/16 LOCKWASHER
80	7	4	* 90332	5/16 (NC) NUT
81	4		90313	5/16 FLATWASHER
82		2	* 90042	5/16 X 1 (NC) GR.5 CAPSCREW
83				
84	1		90614	1/4 X 1-1/4 (NC) GR.5 CAPSCREW
85	1	3	* 90359	1/4 LOCKWASHER
86	1	3	* 90330	1/4 (NC) NUT
87		3	* 90311	1/4 FLATWASHER
88		3	* 90461	1/4 X 3/4 (NC) GR.5 CAPSCREW
89		1	* 90525	7/16 X 6-1/2 (NC) GR.5 CAPSCREW
90		1	* 90362	7/16 LOCKWASHER
91		2	* 90124	3/8 X 2 (NC) GR. 5 CAPSCREW
92		2	* 90361	3/8" LOCKWASHER
93				
94				

FASTENER TORQUE (FT-LB)			
DIAMETER- THREADS PER INCH	GRADE DESIGNATION		
	 GRADE 2	 GRADE 5	 GRADE 8
1/4 - 20	6	9	13
5/16 - 18	11	18	28
3/8 - 16	19	31	46
7/16 - 14	30	50	75
1/2 - 13	45	75	115
9/16 - 12	66	110	165
5/8 - 11	93	150	225
3/4 - 10	150	250	370
7/8 - 9	150	378	591
1 - 8	220	583	893

IMPORTANT NOTICES:

- A.** FISHER ENGINEERING MAKES THE FOLLOWING RESTRICTIONS FOR THIS KIT IN ACCORDANCE WITH FORD MOTOR COMPANY'S MINIMUM RECOMMENDED VEHICLE EQUIPMENT FOR A SNOWPLOW INSTALLATION.

PECULIAR HYDRAULIC KIT HPS4585 IS DESIGNED ONLY FOR USE ON THE FOLLOWING VEHICLES:

1. FORD F350 4WD WITH HEAVY DUTY FRONT SUSPENSION - 5000 LB FRONT GAWR

B. VEHICLE LOADING REQUIREMENTS:

1. THE TOTAL VEHICLE CURB WEIGHT MUST NOT EXCEED THE GROSS VEHICLE WEIGHT (GVW) OR CAUSE EITHER THE FRONT OR REAR GROSS AXLE WEIGHT RATING (GAWR) TO BE EXCEEDED. THE GVW AND GAWRS ARE SPECIFIED ON THE SAFETY COMPLIANCE CERTIFICATION LABEL AFFIXED TO THE VEHICLE. THE VEHICLE CURB WEIGHT INCLUDES ALL AFTER MARKET ACCESSORIES, THE SNOW PLOW SYSTEM INCLUDING THE BLADE, THE VEHICLE OCCUPANTS AND THE CARGO.
2.
 - a. NO MORE THAN 63 PERCENT OF THE TOTAL VEHICLE CURB WEIGHT SHOULD BE SUPPORTED BY THE FRONT AXLE.
 - b. IF NECESSARY, WEIGHT SHOULD BE SECURELY ATTACHED TOWARD THE REAR OF THE VEHICLE TO OBTAIN THIS BALANCE FOR PURPOSES OF COMPLYING WITH FEDERAL MOTOR VEHICLE HYDRAULIC BRAKING STANDARDS.

1. CYLINDER AND CYLINDER HOSE ASSEMBLY

A. USING BENCH VISE TO HOLD LIFT CYLINDER (10), REMOVE CLOSURE FROM PORT. SCREW 90 DEGREE SWIVEL ADAPTOR (46) INTO PORT. PLACE LIFT CYLINDER WITH INSTALLED ADAPTER BETWEEN EARS ON UNDERSIDE OF LIFT ARM AND LOWER HEADGEAR EARS. ATTACH CYLINDER TO EARS USING CLEVIS PINS (12) AND COTTER PINS (15).

B. USING BENCH VISE TO HOLD 32" H.P. HOSE (20), INSTALL FEMALE HALF OF HOSE DISCONNECT ASSEMBLY (42) DIRECTLY TO HOSE. THEN, HOLDING 36" H.P. HOSE (21), INSTALL BRASS BAR STREET ELL (50) AND MALE HALF OF HOSE DISCONNECT ASSEMBLY (42) ON THE SAME HOSE END.

C. USING BENCH VISE TO HOLD ANGLE CYLINDERS (11), REMOVE CLOSURES FROM PORTS AND SCREW BRASS FORGED STREET ELLS (51) INTO PORTS SO THAT ELLS ARE PARALLEL WITH CYLINDER AND POINT TOWARD LIVE END. INSTALL 32" H.P. HOSE WITH FEMALE DISCONNECT HALF TO DRIVER SIDE ANGLE CYLINDER STREET ELL. INSTALL OTHER H.P. HOSE WITH MALE DISCONNECT HALF TO PASSENGER SIDE ANGLE CYLINDER STREET ELL. INSTALL ANGLE CYLINDERS TO "A" FRAME ON THEIR RESPECTIVE SIDES SO THAT ELLS ARE BETWEEN CYLINDERS AND "A" FRAME. SECURE CYLINDERS WITH ANCHOR PINS (13) AT PORT END AND RAM END. SECURE ANCHOR PINS WITH COTTER PINS (15).

2. CONTROL HEAD AND CONTROL CABLES

NOTE: DASH BRACKET, HARDWARE, DRILLING GUIDE AND MOUNTING INSTRUCTIONS WILL BE FOUND IN PECULIAR ATTACHING BOX.

A. DRILL THREE 5/8" HOLES IN FIREWALL FOR CONTROL CABLES AND WIRING HARNESS USING DRILLING GUIDE AS A REFERENCE ONLY. BE SURE BOTH SIDES OF FIREWALL ARE CLEAR OF OBSTRUCTIONS BEFORE DRILLING. DRILL 1/2" HOLE IN UNDERSIDE OF DASH AS SHOWN IN DASH ILLUSTRATION.

B. INSTALL DASH BRACKET AS PER DASH BRACKET INSTRUCTIONS.

C. LOOSEN JAM NUTS ON CONTROL HEAD END OF CABLES (9) AND INSTALL INTO SLOTS IN CONTROL HEAD (8). (RAISE CABLE CENTERS IN BEGINNING OF LOWER SLOT). SNAP CABLE ENDS ONTO BALL STUDS AND TIGHTEN JAM NUTS TO SECURE CABLES TO CONTROL HEAD. REMOVE THE NUTS AND WASHERS FROM THE VALVE END OF THE CABLES. ROUTE THE CABLES OUT THROUGH THE FIREWALL UP TO THE TOP OF THE DRIVER'S SIDE FENDERWELL. ATTACH CONTROL HEAD TO DASH BRACKET AS PER DASH BRACKET INSTRUCTIONS. INSTALL RUBBER GROMMETS (73) AROUND CABLES WHERE THEY PASS THROUGH FIREWALL.

3. VALVE AND VALVE PLATE

A. USING BENCH VISE TO HOLD CONTROL VALVE ASSEMBLY (2) REMOVE CLOSURES FROM VALVE PORTS. SCREW 90 DEGREE SWIVEL ADAPTOR UNIONS (47) INTO "IN" AND "OUT" PORTS. SCREW QUILL (55) INTO INSTALLED ADAPTOR IN "OUT PORT.

NOTE: VALVE FITTINGS ARE INSTALLED AS DESCRIBED TO INSURE PROPER INSTALLATION. FIRST INDICATION OF INCORRECT INSTALLATION IS FAILURE OF PLOW TO LIFT ALTHOUGH PLOW WILL ANGLE.

INSTALL (3) 9/16 O-RING TO 1/4" PIPE ADAPTORS (54) IN LIFT AND ANGLE PORTS. INSTALL ONE 1/4" BRASS BAR ELL (52) TO EACH ADAPTOR. WHEN TIGHT, ELLS SHOULD POINT AWAY FROM CABLE END OF VALVE.

B. MOUNT VALVE TO VALVE PLATE (29) USING TWO 1/4 X 1-1/4 CAPSCREWS, LOCKWASHERS AND NUTS FROM VALVE BAG. CONNECT CONTROL CABLES TO VALVE PLATE BEFORE FASTENING VALVE PLATE TO VEHICLE. BEGIN BY REINSTALLING JAM NUTS AND WASHERS ON CABLES. PLACE CONTROL CABLES IN RESPECTIVE SLOTS OF VALVE PLATE BULKHEAD WITH ONE NUT AND ONE WASHER ON EACH SIDE OF BULKHEAD. CENTER CABLES IN SLOTS SO THAT THEY ARE EXACTLY IN LINE WITH VALVE SPOOL CENTERS. ATTACH CABLE CLEVIS (3) TO CABLES USING SQUARE NUTS (4). SLIP CABLE CLEVISES OVER SPOOLS. INSTALL CLEVIS PIN (5) THROUGH CLEVIS AND SPOOL AND SECURE WITH PUSHNUT (6) ON CLEVIS PIN. TEMPORARILY ADJUST CABLES SO THAT CONTROL LEVER IS SOMEWHERE NEAR CENTERED IN CONTROL HEAD.

C. IF YOUR VEHICLE HAS A BRACKET OVER THE TOP OF THE IGNITION BOX (DRIVER'S SIDE FENDERWELL) IT MUST BE RELOCATED. REMOVE BRACKET, ROTATE 90 DEGREES AND PLACE IT ON THE FENDERWELL. USING MOUNTING HOLES IN BRACKET AS A GUIDE, MARK AND DRILL THREE 9/32" HOLES. FASTEN BRACKET TO INNER FENDER WITH THREE 1/4 X 3/4 CAPSCREWS (88), FLATWASHERS (87), LOCKWASHERS (85) AND NUTS (86).

D. IF YOUR VEHICLE IS EQUIPPED WITH CRUISE CONTROL, TEMPORARILY REMOVE UNIT TO ALLOW INSTALLATION OF VALVE. RETURN UNIT TO ITS ORIGINAL LOCATION AFTER VALVE HAS BEEN INSTALLED. VEHICLES WITH CRUISE CONTROL ARE ALSO EQUIPPED WITH A CANISTER ON THE DRIVER'S SIDE FENDERWELL. THIS CANISTER MUST BE RELOCATED. TO RELOCATE, REMOVE WINDSHIELD WIPER GROUND WIRE FROM THE SELF-TAPPING SCREW IN FIREWALL. REMOVE SCREW FROM FIREWALL AND PLACE THROUGH HOLE IN LEG OF CANISTER BRACKET (33). FASTEN ASSEMBLY TO ORIGINAL HOLE. REMOVE CANISTER FROM FENDERWELL AND FASTEN ONTO BRACKET USING ORIGINAL FASTENERS.

E. ALIGN VALVE PLATE ON PLASTIC INNER FENDER SO THAT CABLES RUN IN AS STRAIGHT AND SMOOTH A PATH AS POSSIBLE. USING THE MOUNTING HOLES IN THE VALVE PLATE AS GUIDES, DRILL (4) 11/32" HOLES THROUGH INNER FENDER. FASTEN VALVE PLATE TO INNER FENDER WITH (4) 5/16 X 1-1/2 (NC) CAPSCREWS (77), (2) BACKING PLATES (32), LOCKWASHERS (79) AND NUTS (80).

F. WITH VALVE PLATE FASTENED TO INNER FENDER, READJUST CONTROL CABLES SO THAT CONTROL HEAD LEVER IS CENTERED BETWEEN BOTH ANGLE AND RAISE/LOWER POSITIONS. IF CABLE CLEVIS DOES NOT ALLOW ENOUGH ADJUSTMENT, REPOSITION CABLE AT VALVE PLATE BULKHEAD. AFTER CHECKING TO SEE THAT THE VALVE SPOOLS ARE IN THE CENTERED POSITION, TIGHTEN CABLE CLEVIS NUTS.

CAUTION: VALVE SPOOLS MUST BE FREE AND SELF CENTERING WHEN CABLES AND CONTROL HEAD ARE ATTACHED. FAILURE TO CENTER SPOOLS WILL RESTRICT FLUID FLOW THROUGH VALVE. THIS MAY CAUSE HYDRAULIC FLUID TO OVERHEAT RESULTING IN PUMP DAMAGE AND OR HYDRAULIC HOSE FAILURE. HOSE FAILURES CAN CAUSE ENGINE FIRES.

WHEN ADJUSTED, THE CONTROL LEVER MUST BE IN THE NEUTRAL POSITION TO ALLOW ENOUGH SPOOL TRAVEL EACH WAY FOR PROPER VALVE ACTUATION.

4. PUMP TANK AND PUMP BRACKET

A. VEHICLES W/O A.C. - LOOSEN POWER STEERING PUMP. REMOVE TWO 3/8" BOLTS HOLDING THE POWER STEERING PUMP BRACKET TO THE WATER PUMP. REMOVE THE POWER STEERING PUMP PIVOT BOLT AND INNER POWER STEERING V-BELT.

VEHICLES W/A.C. - REMOVE AND SAVE AIR CONDITIONER BELT. LOOSEN POWER STEERING PUMP AND REMOVE BELT. REMOVE TWO 3/8" BOLTS HOLDING THE POWER STEERING PUMP BRACKET TO THE WATER PUMP. REMOVE THE POWER STEERING PUMP PIVOT BOLT AND INNER POWER STEERING V-BELT.

B. VEHICLES W/O A.C. - INSTALL LONG END OF BRACE TAB (38) TO THE FORWARD INTAKE MANIFOLD BOLT ON THE DRIVER'S SIDE. REUSE THE EXISTING FASTENER.

VEHICLES W/A.C. - REMOVE NUT FROM ADJUSTING BOLT IN AIR CONDITIONER. PLACE LONG LEG OF BRACE TO ONTO BOLT AND FASTEN WITH ORIGINAL NUT.

C. INSTALL PUMP BRACKET (26) ONTO THE FRONT OF THE POWER STEERING PUMP BRACKET USING TWO 3/8 X 2 (NC) GR. 5 CAPSCREWS (91) AND LOCKWASHERS(92) INTO POWER STEERING BRACKET MOUNTING HOLES. INSTALL A 7/16 X 6-1/2 (NC) GR. 5 CAP (89) AND LOCKWASHER (90) IN PLACE OF THE POWER STEERING PUMP PIVOT BOLT.

D. TO INSTALL PUMP BRACKET BRACE (27), REMOVE AND DISCARD FRONT LOWER DRIVER'S SIDE VALVE COVER BOLT (SAVE SPACER). FASTEN WITH A 5/16 X 1 GR. 5 CAPSCREW (82) AND LOCKWASHER (79) THROUGH HOLE IN BENT END OF BRACE AND VALVE COVER HOLE. ATTACH OTHER END OF THE BRACE TO THE TAB ON THE PUMP BRACKET USING A 5/16 X 1 GR. 5 CAPSCREW (82), LOCKWASHER (79) AND NUT (80).

E. HOLDING PUMP TANK (1) IN BENCH VISE, SCREW ADAPTOR UNION (49) ONTO PRESSURE PORT OF PUMP AND SCREW QUILL (55) INTO RETURN PORT OF PUMP. INSTALL PUMP SHEAVE (25) ONTO PUMP SHAFT USING LOCKNUT AND KEY SUPPLIED WITH PUMP. WHEN INSTALLING LOCKNUT MAKE SURE THAT THE LOCKNUT TIGHTENS AGAINST THE PUMP SHEAVE, AND NOT AGAINST THE PUMP SHAFT SHOULDER. AN OPTIONAL 1/2 PLAIN WASHER (101) SHOULD BE INSTALLED ONLY IF THE LOCKNUT TIGHTENS AGAINST THE PUMP SHAFT SHOULDER AND NOT THE SHEAVE.

CAUTION: TO AVOID DAMAGE TO THE PUMP SHAFT, MAKE SURE THAT THE 1/2 FLATWASHER FITS ON OVER THE SHAFT SHOULDER BEFORE TIGHTENING THE LOCKNUT.

REMOVE PUMP FROM VISE AND INSTALL SADDLE BRACKET (35) ON OVER FRONT OF PUMP. SECURE WITH A 5/16 X 1-1/2 GR. 5 CAPSCREW (77), LOCKWASHER (79) AND NUT (80). ATTACH SADDLE BRACKET AND PUMP TO PUMP BRACKET USING TWO 5/16 X 1 CAPSCREWS (78), FLATWASHER (81), LOCKWASHERS(79) AND NUTS(80).

F. VEHICLES W/O A.C. - INSTALL 76" V-BELT (23) ON OVER CRANKSHAFT PULLEY, WATER PUMP PULLEY, POWER STEERING PULLEY AND PUMP SHEAVE.

VEHICLES W/A.C. - INSTALL 76" V-BELT OVER CRANKSHAFT PULLEY, WATER PUMP PULLEY, AIR CONDITIONER PULLEY AND PUMP SHEAVE.

CAUTION: THE BELT WHICH DRIVES THE FISHER HYDRAULIC SYSTEM DOES NOT MAKE ADEQUATE CONTACT WITH THE AIR CONDITIONING PULLEY TO DRIVE THE COMPRESSOR. BEFORE USING THE AIR CONDITIONING, REMOVE THE FISHER BELT AND REINSTALL THE ORIGINAL VEHICLE BELT.

ALIGN SHEAVES AND TIGHTEN 1-1/2" SADDLE BRACKET FASTENER. TIGHTEN POWER STEERING PUMP FIRST AND THEN FISHER PUMP. ADJUST FOR PROPER TENSION BY PIVOTING SADDLE BRACKET ON TOP BOLT. INSTALL REAR TANK STRAP (36) ON OVER REAR OF PUMP TANK. INSTALL ONE 5/16 NUT (80) AND FLATWASHER (81) ONTO UNIVERSAL BRACE ROD (37) AND INSERT BRACE ROD THROUGH PREVIOUSLY INSTALLED UNIVERSAL BRACE TAB. INSTALL BRACE ROD TO TANK STRAP WITH ONE 1/4 X 1-1/4 CAPSCREW (84), LOCKWASHER (85) AND NUT (86). FASTEN OTHER END OF BRACE ROD TO BRACE TAB WITH A 5/16 FLATWASHER (81), 5/16 LOCKWASHER (79) AND NUT (80). USE BRACE ROD TO ADJUST ALIGNMENT OF DRIVE AND PUMP SHEAVES. CHECK BELT FOR PROPER TENSION. TIGHTEN POWER STEERING AND ALTERNATOR BELTS.

G. REINSTALL AND TIGHTEN ALL VEHICLE BELTS.

5. HYDRAULIC HOSE INSTALLATION

A. ATTACH ONE END OF 32" H.P. HOSE (16) TO THE 1/4" BRASS BAR ELL ON PUMP TANK AND PUSH ONE END OF 28" L.P. HOSE (17) ONTO THE QUILL ON PUMP TANK. ROUTE THESE HOSES TO THE CONTROL VALVE.

CAUTION: KEEP HOSES AWAY FROM HOT OR MOVING ENGINE COMPONENTS. FAILURE TO DO SO MAY CAUSE HOSE TO BURST RESULTING IN A POSSIBLE ENGINE FIRE.

PUSH L.P. HOSE ONTO QUILL AND SCREW H.P. HOSE INTO 90 DEGREE SWIVEL ADAPTOR. INSTALL 66" H.P. HOSE (18) TO BRASS ELL IN LIFT CYLINDER PORT OF VALVE (SPOOL #1). INSTALL TWO 54" H.P. HOSES (19) TO BRASS ELLS IN ANGLE PORTS OF VALVE (SPOOL #2). ROUTE 66" AND 54" HOSES OUT THROUGH RADIATOR WEB AND THROUGH GRILL NEAR CENTER OF VEHICLE. (IF VEHICLE IS EQUIPPED WITH LARGE RADIATOR, THE DRIVER'S SIDE BATTERY MUST BE REMOVED AND AN 1-7/8" HOLE DRILLED THROUGH THE RADIATOR WEB.) INSTALL SPLIT HOSE GROMMET (74) AROUND HOLE TO PROTECT HOSES FROM ANY SHARP EDGES. ATTACH 66" HOSE TO PREVIOUSLY INSTALLED 90 DEGREE SWIVEL ADAPTOR ON LIFT CYLINDER.

6. DISCONNECT ASSEMBLY

A. WITH DISCONNECT MOUNTING PLATE (39) HELD IN BENCH VISE, INSTALL DISCONNECT HALVES AS SHOWN IN ILLUSTRATION. BULKHEAD ADAPTOR (44) AND MALE DISCONNECT HALF (42) GO IN BOTTOM HOLE. FEMALE DISCONNECT HALF (42) GOES IN TOP HOLE. SECURE BOTH WITH 7/8" SNAP RINGS (45). ATTACH MOUNTING PLATE TO BACK OF DRIVERS SIDE HEADGEAR POST WITH TWO 5/16 X 1 CAPSCREWS (78), LOCKWASHERS (79) AND NUTS (80). INSTALL DUST PLUGS (43) OVER ENDS OF HOSES ROUTED TO FRONT OF VEHICLE IN THE PREVIOUS STEP. CONNECT 54" RIGHT ANGLE HOSE (SPOOL #2, CYL. B) TO BACK OF FEMALE DISCONNECT INSTALLED IN TOP HOLE OF DISCONNECT BRACKET. CONNECT 54" LEFT ANGLE HOSE (SPOOL #2, CYL. A) TO BOTTOM (MALE) DISCONNECT. TIGHTEN BY HOLDING HOSES AND ROTATING THE DISCONNECT HALVES IN THE BRACKET.

7. OPERATIONS

A. CHECK ALL FITTINGS AND FASTENERS FOR TIGHTNESS. SECURE HOSES WITH NYLON TIE WRAPS (75). PLACE SAFETY DECAL (72) ON DASH BESIDE CONTROL HEAD.

B. FILL RESERVOIR WITH TYPE "A" AUTOMATIC TRANSMISSION FLUID. START ENGINE, LIFT AND ANGLE BLADE. NOTE: IF BLADE ANGLES OPPOSITE FROM CONTROL LEVER POSITION, REVERSE THE TWO H.P. HOSE CONNECTIONS ON THE BACK OF THE DISCONNECT BRACKET. RAISE FRONT END OF VEHICLE UNTIL PLOW IS CLEAR OF GROUND WITH THE LIFT CYLINDER FULLY RETRACTED. CHECK RESERVOIR OIL LEVEL. ANGLE BLADE (WITH LIFT CYLINDER RETRACTED) TO REMOVE AIR FROM SYSTEM. RECHECK RESERVOIR OIL LEVEL.