

SNOWPLOWS



Models 680LT & 720LT

Installation Instructions & Owner's Manual

⚠ CAUTION

See your BLIZZARD sales outlet/Web site for specific vehicle application recommendations before installation. The Undercarriage Selection Guide has specific vehicle and snowplow requirements.

⚠ CAUTION

Read this document before installing the snowplow.

⚠ CAUTION

Read this document before operating or servicing snowplow.

This manual supersedes all editions with an earlier date.

PREFACE

Congratulations on purchasing the finest straight blade snowplow available! BLIZZARD® straight blades are clearing new trails for innovative design, rugged durability, quality craftsmanship and superior performance. Our innovative products are tested all over the snowbelt.

This manual provides safety, operation and maintenance information for your new BLIZZARD snowplow. To keep your snowplow in good condition, read and understand this manual and follow its recommendations. Failure to do so may affect your warranty coverage.

When service is necessary, your local BLIZZARD distributor knows your snowplow best. Contact your BLIZZARD outlet for maintenance, service or any other assistance you may require.

If you have not already done so, please visit www.blizzardplows.com to register your new BLIZZARD snowplow!

TABLE OF CONTENTS

Preface	2	POWER HITCH™ System Instructions	30
Safety Information	4	Testing Your Snowplow	31
Vehicle Application Information	7	Headlamp Aiming	33
Operation	8	Maintenance	34
Unpacking & Inspection	9	Technical Specifications	35
Torque Specifications	10	Troubleshooting	36
Moldboard & A-Frame Assembly	12	Parts Lists	38
Electrical & Hydraulic Systems	16	Moldboard Parts – All Models	38
Manifold Assembly &		A-Frame & Pivot Beam Parts – All Models	40
Electrical Installation – Snowplow Side	16	Power Unit Parts – All Models	42
General System Schematics	18	Lights & Control Parts – All Models	44
Hydraulic Guide	19	Accessories & Kits – All Models	46
Electrical Schematics – Snowplow Side	20		
Electrical Installation – Vehicle Side	23		
Electrical Schematics – Vehicle Side	26		

SAFETY

SAFETY DEFINITIONS

⚠ WARNING

Indicates a potentially hazardous situation, that if not avoided, could result in death or serious personal injury.

⚠ CAUTION

Indicates a potentially hazardous situation that, if not avoided, may result in minor or moderate injury. It may also be used to alert against unsafe practices.

NOTE: Indicates a situation or action that can lead to damage to your snowplow and vehicle or other property. Other useful information can also be described.

WARNING/CAUTION & INSTRUCTION LABELS

Become familiar with and inform users about the warning and instruction labels on the back of the blade.

NOTE: If labels are missing or cannot be read, see your sales outlet.

MOUNT INSTRUCTIONS		DISMOUNT INSTRUCTIONS	
Read Owner's Manual for Complete Instructions.		Read Owner's Manual for Complete Instructions.	
<p>STEP #1</p> <p>CONNECT/DISCONNECT POWER HITCH SWAY</p> <p>Labels: Pushbeam Receiver, Undercarriage Pushbeam, Kickstand, Adjustable Kickstand, Mount Base, POWER HITCH SWAY, Slowly Move Vehicle Forward.</p> <p>⚠ WARNING: Keep fingers away. POWER HITCH arm raises behind undercarriage pushbeam.</p> <ul style="list-style-type: none"> Kickstand must be lowered, with kickstand pin seated in lower hole on pivot beam. Slowly drive vehicle forward until pushbeam receiver mount points contact A-frame mount bushings. Turn POWER HITCH OPERATION switch (on plow control) to "ON" position. Connect plow and vehicle electrical harnesses. Connect weather caps together. 	<p>STEP #1</p> <p>CONNECT/DISCONNECT POWER HITCH SWAY</p> <p>Labels: Kickstand, Kickstand Pin, POWER HITCH SWAY, Slowly Move Backward.</p> <ul style="list-style-type: none"> Raise plow. Lower kickstand and kickstand pin is seated in lower hole on pivot beam. Lower plow on flat, level surface. Turn vehicle ignition off. Remove hitch pins from A-frame and undercarriage. Turn vehicle ignition on. Turn POWER HITCH OPERATION switch (on plow control) to "ON" position. 		
<p>STEP #2</p> <p>LOWER PLOW</p> <p>Labels: A-Frame Latch, Lock Pin, A-Frame Latch, Lock Pin, Lower Plow, Lower Plow, Lower Plow, Lower Plow.</p> <ul style="list-style-type: none"> Pull A-frame latch lock pin out and lower A-frame latch over draw pin. Push and hold CONNECT/DISCONNECT switch upward. POWER HITCH arm will engage back of pushbeam and pull plow into pushbeam receiver mount points on vehicle. Insert both hitch pins and secure each with hat pin cotter. Lower POWER HITCH arm to relieve tension on A-frame latch. Raise A-frame latch and lock into position with lock pin. Raise plow. Raise kickstand until kickstand pin seats into upper hole on pivot beam. 	<p>STEP #2</p> <p>CONNECT/DISCONNECT POWER HITCH SWAY</p> <p>Labels: Kickstand Pin, Adjustable Kickstand, POWER HITCH SWAY, Slowly Move Backward.</p> <p>⚠ WARNING: Keep fingers away from plow and truck mounting points.</p> <ul style="list-style-type: none"> Push and hold CONNECT/DISCONNECT switch downward. POWER HITCH arm will disengage from behind undercarriage pushbeam and lower. Disconnect plow and vehicle electrical harnesses. Install weather caps. Turn SYSTEM POWER (on plow control) to "OFF" position. Slowly move vehicle backward away from plow. 		

U.S. Patents 5,638,616; 5,889,007; 6,178,669; 6,276,076; 6,393,737; 6,408,549; 6,412,159; 6,442,877; 6,615,513. Canadian and other patents pending.

⚠ WARNING

LOWER BLADE WHEN VEHICLE IS PARKED.

DO NOT EXCEED GVWR OR GAWR INCLUDING BLADE AND BALLAST.

REMOVE BLADE ASSEMBLY BEFORE PLACING VEHICLE ON HOIST.

⚠ CAUTION

READ OWNER'S MANUAL BEFORE OPERATING OR SERVICING SNOWPLOW.

TRANSPORT SPEED SHOULD NOT EXCEED 45 MPH. FURTHER REDUCE SPEED UNDER ADVERSE TRAVEL CONDITIONS.

PLOWING SPEED SHOULD NOT EXCEED 10 MPH.

SEE YOUR SALES OUTLET/WEB SITE FOR SPECIFIC VEHICLE APPLICATION RECOMMENDATIONS.

59900

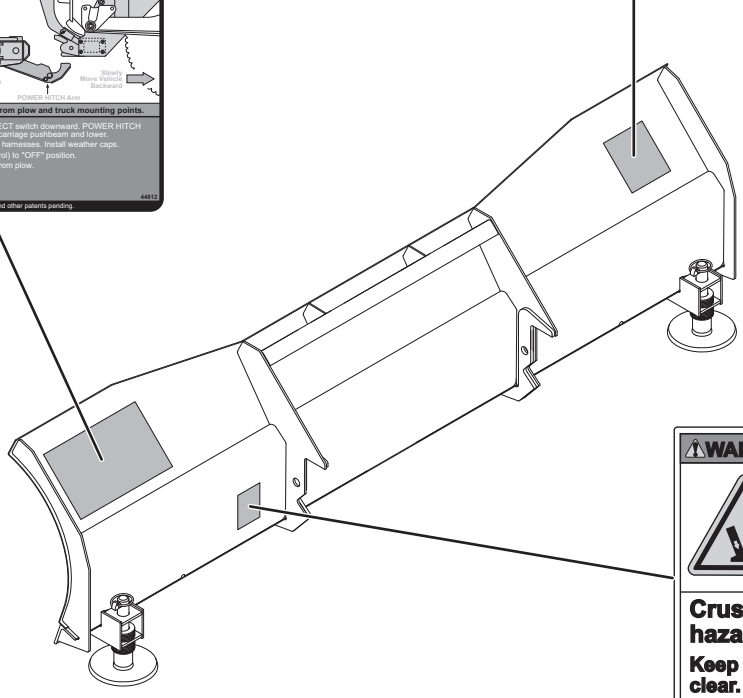

⚠ WARNING

Crush hazard.
Keep feet clear.

SAFETY

SAFETY PRECAUTIONS

Improper installation and operation could cause personal injury, and/or equipment and property damage. Read and understand labels and the Owner's Manual before installing, operating or making adjustments.

⚠ WARNING

Lower blade when vehicle is parked. Temperature changes could change hydraulic pressure, causing the blade to drop unexpectedly or damaging hydraulic components. Failure to do this could result in serious personal injury.

⚠ WARNING

You can die or be seriously injured. Keep hands and feet away from hitch mechanism and snowplow blade when operating the POWER HITCH™ arm. The action of the arm moves the snowplow toward the vehicle and into position for proper attachment.

⚠ WARNING

The driver shall keep bystanders clear of the blade when it is being raised, lowered or angled. Do not stand between the vehicle and the blade or within 8 feet of a moving blade. A moving or falling blade could cause personal injury.

⚠ WARNING

Do not exceed GVWR or GAWR including the blade and ballast. The rating label is found on the driver-side vehicle door cornerpost.

⚠ WARNING

To prevent accidental movement of the blade, always turn the control OFF whenever the snowplow is not in use. The power indicator light will turn OFF.

⚠ WARNING

Remove blade assembly before placing vehicle on hoist.

⚠ CAUTION

Read Owner's Manual before operating or servicing snowplow.

⚠ CAUTION

Transport speed should not exceed 45 mph. Further reduce speed under adverse travel conditions.

⚠ CAUTION

Plowing speed should not exceed 10 mph.

⚠ CAUTION

See your BLIZZARD® outlet for application recommendations.

HYDRAULIC SAFETY

⚠ WARNING

Hydraulic fluid under pressure can cause skin injection injury. If you are injured by hydraulic fluid, get medical attention immediately.

- Always inspect hydraulic components and hoses before using. Replace any damaged or worn parts immediately.
- If you suspect a hose leak, DO NOT use your hand to locate it. Use a piece of cardboard or wood.

FUSES

The snowplow electrical and hydraulic systems contain several blade-style automotive fuses. If a problem should occur and fuse replacement is necessary, the replacement fuse must be of the same type and amperage rating as the original. Installing a fuse with a higher rating can damage the system and could start a fire. Fuse Replacement, including fuse ratings and locations, is located in the Maintenance Section of this Owner's Manual.

SAFETY

PERSONAL SAFETY

- Remove ignition key and put the vehicle in park or in gear to prevent others from starting the vehicle during installation or service.
- Wear only snug-fitting clothing while working on your vehicle or snowplow.
- Do not wear jewelry or a necktie, and secure long hair.
- Wear safety goggles to protect your eyes from battery acid, gasoline, dirt and dust.
- Avoid touching hot surfaces such as the engine, radiator, hoses and exhaust pipes.
- Always have a fire extinguisher rated BC handy, for flammable liquids and electrical fires.

FIRE AND EXPLOSION

⚠ WARNING

Gasoline is highly flammable and gasoline vapor is explosive. Never smoke while working on vehicle. Keep all open flames away from gasoline tank and lines. Wipe up any spilled gasoline immediately.

Be careful when using gasoline. Do not use gasoline to clean parts. Store only in approved containers away from sources of heat or flame.

CELL PHONES

A driver's first responsibility is the safe operation of the vehicle. The most important thing you can do to prevent a crash is to avoid distractions and pay attention to the road. Wait until it is safe to operate Mobile Communication equipment such as cell phones or two-way radios.

VENTILATION

⚠ WARNING

Vehicle exhaust contains lethal fumes. Breathing these fumes, even in low concentrations, can cause death. Never operate a vehicle in an enclosed area without venting exhaust to the outside.

BATTERY SAFETY

⚠ CAUTION

Batteries normally produce explosive gases which can cause personal injury. Therefore, do not allow flames, sparks or lit tobacco to come near the battery. When charging or working near a battery, always cover your face and protect your eyes, and also provide ventilation.

Batteries contain sulfuric acid which burns skin, eyes and clothing.

Disconnect the battery before removing or replacing any electrical components.

NOISE

Airborne noise emission during use is below 70 dB(A) for the snowplow operator.

VEHICLE APPLICATION INFORMATION

⚠ CAUTION

See your BLIZZARD® outlet for specific vehicle application recommendations before installation. The Undercarriage Selection Guide has specific vehicle and snowplow requirements.

Vehicle application recommendations are based on the following:

- The vehicle with the snowplow installed must comply with applicable Federal Motor Vehicle Safety Standards (FMVSS).
- The vehicle with the snowplow installed must comply with the vehicle manufacturer's stated gross vehicle and axle weight ratings (found on the driver-side door cornerpost of the vehicle) and the front and rear weight distribution ratio. In some cases, rear ballast may be required to comply with these requirements.
- BLIZZARD Undercarriage Selection Guide is based on available vehicle capacity for snowplow equipment on a representative vehicle equipped with options commonly used for plowing and with 300 lb of front seat occupant weight.
- Weights of front seat occupants can be adjusted above 300 lb but vehicle with snowplow must not exceed vehicle GVWR or GAWR.
- In some cases there may be additional limitations and requirements.
- Installation, modification and addition of accessories must comply with published BLIZZARD recommendations and instructions. Available capacity decreases as the vehicle is loaded with cargo or other truck equipment or snowplow accessories are installed.
- If there is uncertainty as to whether available capacity exists, the actual vehicle as configured must be weighed.

BALLAST REQUIREMENTS

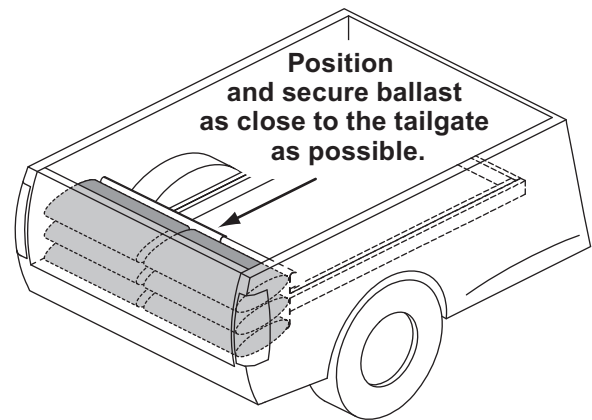

Ballast (additional weight) is an important part of qualifying vehicles for snowplow eligibility. Rear ballast must be used when necessary to remain in compliance with axle ratings and ratios as specified by the vehicle manufacturer.

If ballast is required, it is important that it be secured properly behind the rear axle. A ballast retainer kit is available from your BLIZZARD outlet, PN 62849.

NOTE: The ballast retainer kit is for snowplow vehicles requiring ballast. See your BLIZZARD outlet for the correct amount of ballast required. Include the weight of the retainer as part of the ballast requirement. Sand bags are recommended for use as ballast.

NOTE: Ballast recommended and its weight calculations assume the entire width of the bed is filled as close to tailgate as possible.

OPERATION

Your snowplow is the most advanced and versatile straight blade on the market. The easy-to-use controls allow you to automatically adjust the snowplow blade into an infinite number of plowing positions. Review the illustrations below for instruction on maneuvering your snowplow.

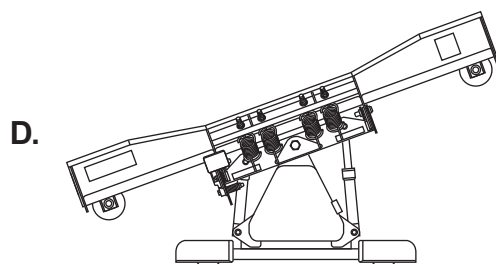
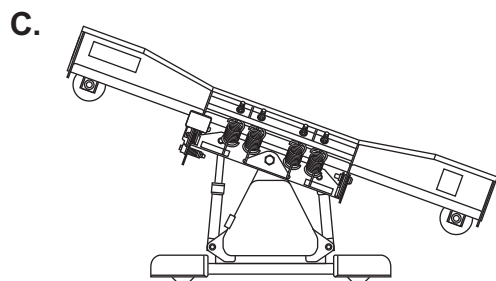
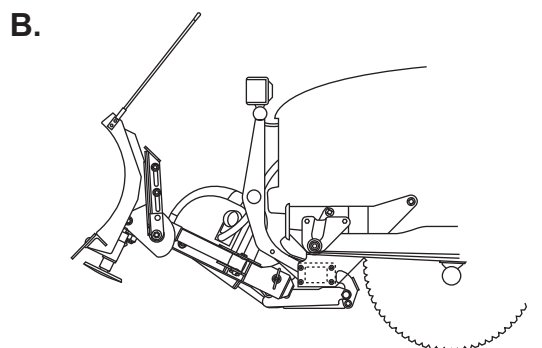
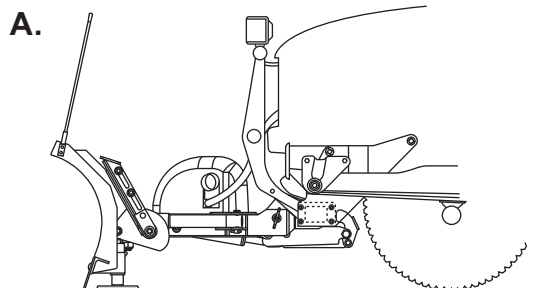

A. Lowered or Float Position

Pushing the joystick forward, toward the "Lower/Float" designation on the label, or pushing the D button on the touchpad will lower your straight blade to the ground. Pushing and momentarily holding the control in this position will allow the snowplow to "float," or follow the contour of the ground when moving forward or backward.

B. Raised Position

Pulling the joystick back, toward the "Raise" designation on the label, or pushing the U button on the touchpad will lift your straight blade off the ground. To stop raising the snowplow, simply return the joystick to its "neutral" or center position or release the touchpad button. The snowplow has reached its maximum raised position when the blade stops lifting.

C. Angled Right Position

To angle your straight blade to the right, position the joystick toward the "R" on the label or push the R button on the touchpad. To stop angling the snowplow, return the joystick to its "neutral" or center position or release the touchpad button. The snowplow has reached its maximum angled position when the blade stops moving to the right side.

D. Angled Left Position

To angle your straight blade to the left, position the joystick toward the "L" on the label or push the L button on the touchpad. To stop angling the snowplow, return the joystick to its "neutral" or center position or release the touchpad button. The snowplow has reached its maximum angled position when the blade stops moving to the left side.

NOTE: To prevent premature failure of the power contactor (solenoid), return the joystick to its neutral (center) position or release the touchpad button immediately after the blade reaches the limit of any position. Continuing to hold the control after the blade has reached the limit of movement in any position will reduce the life of the solenoid.

UNPACKING & INSPECTION

Your BLIZZARD® straight blade has been packaged to withstand transit and weather related damage. Fully inspect all components upon receipt of your snowplow. In the event of shipping damage or missing parts, immediately contact our Customer Service Department at 1-888-680-8600.

Begin unpacking and inspection in the following order:

1. Remove the shipping document from the end panel of the pallet wrap. Retain all documentation for your records.
2. All wood framing and polyethylene material should be removed from the pallet for easy access to the snowplow.
3. Due to the odd shaped components and size of several assembly parts, various cable ties and corrugated material are used for scratch resistance and package orientation. Please remove these items prior to assembly.
4. Place the main blade assembly on a flat, level surface.

Once you have inspected all parts and removed all packaging materials, your snowplow is ready to be fully assembled.

Retain this information for your records.

Date of Purchase: _____

Dealer/Distributor: _____

Dealer Phone Number: _____

Snowplow Serial Number: _____

Hydraulic Pump Serial Number: _____

TORQUE SPECIFICATIONS

TORQUE CHART

⚠ CAUTION

Read instructions before assembling. Fasteners should be finger tight until instructed to tighten according to the torque chart. Use standard methods and practices when attaching snowplow including proper personal protective safety equipment.



Grade Identification for J429–Grade 5 Bolt



Grade Identification for J429–Grade 8 Bolt

SAE J429 Grade 5 Torque Values				SAE J429 Grade 8 Torque Values			
Nominal Thread Size	Clamp Loads (lb)	Tightening Torque		Nominal Thread Size	Clamp Loads (lb)	Tightening Torque	
		"Lubricated"	"Dry"			"Lubricated"	"Dry"
1/4-20	2,000	6 ft-lb	8 ft-lb	1/4-20	2,850	9 ft-lb	12 ft-lb
5/16-18	3,350	13 ft-lb	18 ft-lb	5/16-18	4,700	18 ft-lb	25 ft-lb
3/8-16	4,950	23 ft-lb	31 ft-lb	3/8-16	6,950	32 ft-lb	44 ft-lb
7/16-14	6,800	37 ft-lb	50 ft-lb	7/16-14	9,600	53 ft-lb	70 ft-lb
1/2-13	9,050	57 ft-lb	75 ft-lb	1/2-13	12,800	80 ft-lb	107 ft-lb
9/16-12	11,600	82 ft-lb	109 ft-lb	9/16-12	16,400	115 ft-lb	154 ft-lb
5/8-11	14,500	113 ft-lb	151 ft-lb	5/8-11	20,300	159 ft-lb	211 ft-lb
3/4-10	21,300	200 ft-lb	266 ft-lb	3/4-10	30,100	282 ft-lb	376 ft-lb
7/8-9	29,435	321 ft-lb	430 ft-lb	7/8-9	41,550	454 ft-lb	606 ft-lb
1-8	38,600	482 ft-lb	640 ft-lb	1-8	54,540	680 ft-lb	900 ft-lb



8.8 Grade Identification for Metric–Grade 8.8 Bolt



10.9 Grade Identification for Metric–Grade 10.9 Bolt

Metric Class 8.8 Torque Values				Metric Class 10.9 Torque Values			
Diameter (mm)	Clamp Loads (lb)	Tightening Torque		Diameter (mm)	Clamp Loads (lb)	Tightening Torque	
		"Lubricated"	"Dry"			"Lubricated"	"Dry"
5	1,389	3 ft-lb	5 ft-lb	5	1,987	5 ft-lb	7 ft-lb
6	1,965	6 ft-lb	8 ft-lb	6	2,812	8 ft-lb	11 ft-lb
7	2,826	10 ft-lb	13 ft-lb	7	4,044	14 ft-lb	19 ft-lb
8	3,579	14 ft-lb	19 ft-lb	8	5,121	20 ft-lb	27 ft-lb
10	5,672	28 ft-lb	37 ft-lb	10	8,116	40 ft-lb	53 ft-lb
12	8,243	49 ft-lb	65 ft-lb	12	11,796	70 ft-lb	92 ft-lb
14	11,246	77 ft-lb	103 ft-lb	14	16,092	111 ft-lb	148 ft-lb
16	15,882	125 ft-lb	167 ft-lb	16	21,970	173 ft-lb	231 ft-lb
18	19,423	172 ft-lb	229 ft-lb	18	26,868	238 ft-lb	317 ft-lb
20	24,784	244 ft-lb	325 ft-lb	20	34,284	338 ft-lb	450 ft-lb

TORQUE SPECIFICATIONS

37° JIC Flare Torque Values			
Turns	Size	ft-lb min-max	Assembly Steps
N/A	-02	6-7	<ol style="list-style-type: none"> 1. Make sure the tubing and threads are clean. 2. Lubricate the threads with 10W hydraulic fluid. 3. Hand tighten the nut/sleeve to approximately 30 in-lb. 4. Make alignment marks on the nut and fitting. 5. Tighten to turn or torque specification. 6. When fully tightened, make a second set of alignment marks at the fully tightened position. <p>NOTE: Torque values specified are for threads lubricated with 10W hydraulic fluid. Overtightening will reduce the clamping force resulting in loss of seal and reduction of flow.</p>
N/A	-03	8-9	
2	-04	11-12	
2	-05	14-15	
1-1/2	-06	18-20	
1-1/2	-08	36-39	
1-1/2	-10	57-63	
1-1/4	-12	79-88	
1	-14	94-103	
1	-16	108-113	
1	-20	127-133	
1	-24	158-167	
1	-32	245-258	

O-Ring Boss Torque Values		
Size	ft-lb min-max	Assembly Steps
-02	6-7	<ol style="list-style-type: none"> 1. Verify the port, O-ring, sealing surfaces and threads are clean and free of damage. 2. Lubricate the threads and the O-ring with 10W hydraulic fluid. 3. For an adjustable ORB, completely back off the locknut and washer. 4. Hand tighten the fitting until it contacts the port spotface. Point the elbow or tee in the desired direction and hold. 5. Torque to specification. <p>NOTE: Torque values specified are for threads lubricated with 10W hydraulic fluid.</p>
-03	8-10	
-04	13-15	
-05	17-21	
-06	22-25	
-08	40-43	
-10	43-57	
-12	68-75	
-14	90-99	
-16	112-123	
-20	146-200	
-24	154-215	
-32	218-290	

MOLDBOARD & A-FRAME ASSEMBLY

1. Position the pivot beam and A-frame near the connecting points at the rear of the blade between the two center support ribs. Insert one $\frac{3}{4}$ " x $3\text{-}7/16$ " clevis pin through each mounting hole and secure with $\frac{1}{4}$ " x $1\text{-}1/2$ " cotter pin.

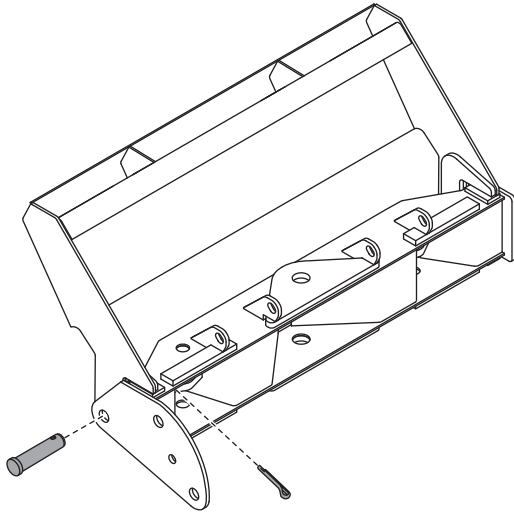

2. Mount the kickstand to the end of the pivot beam (driver's side) using the $\frac{1}{2}$ " x $4\text{-}1/2$ " bolt provided. The spring, bushing and locknut are located on the inside of the pivot beam. Review the diagrams below and to the right. To pivot the kickstand, pull the spring loaded leg out and rotate it until the pin locks into place. Adjust the foot on the stand arm so that the foot is $\frac{1}{8}$ " from the ground when the A-frame is level and the A-frame mount points are $10\text{-}1/2$ " from the ground. Tighten both of the locknuts on the kickstand.

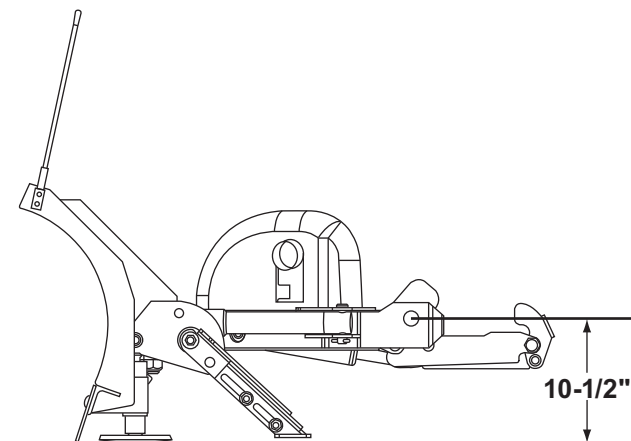
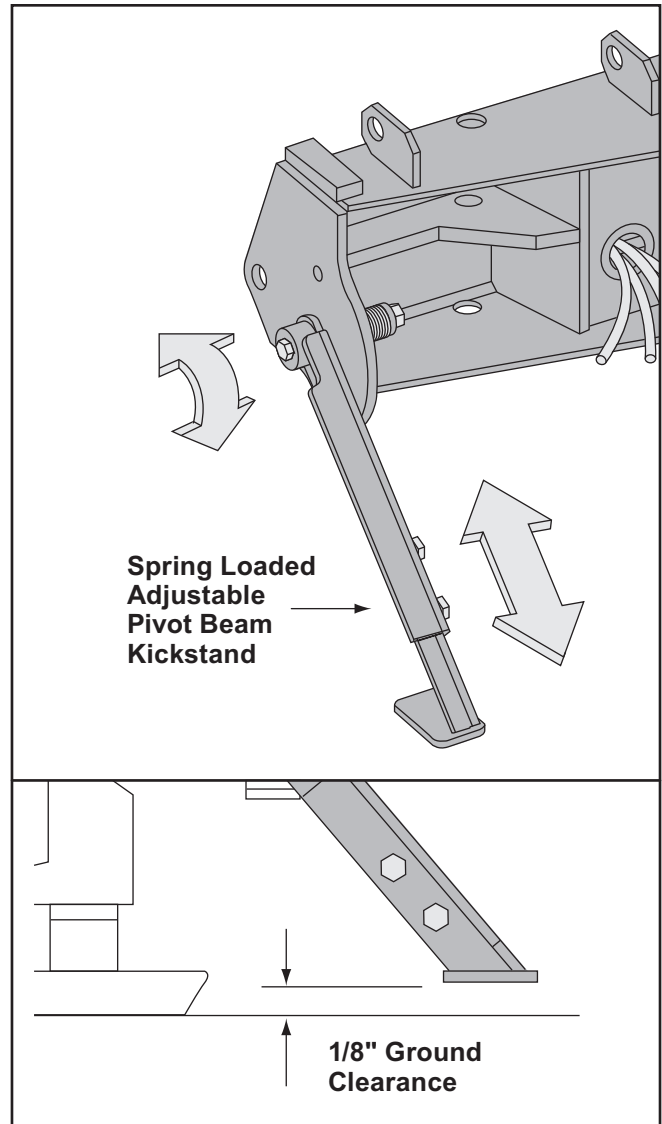

MOLDBOARD & A-FRAME ASSEMBLY

- Hook each extension spring to the receiving holes on the pivot beam and attach the opposite end of the spring to its respective spade bolts. Install the spade bolts through the extension spring mounting angle on the top rear of the blade. Secure each spade bolt by placing one 5/8" flat washer on the bolt and thread one 5/8" locknut. Tighten each locknut until a piece of paper can pass between the 3rd and 4th coils on the spring.

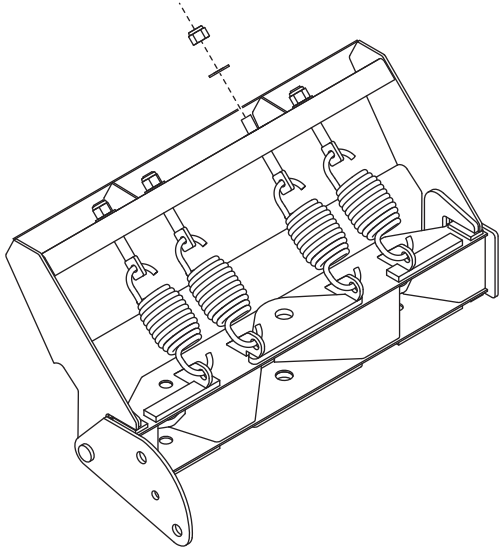

- Install the blade guides at each end of the moldboard. Insert the cap screw through the holes at the top of the wing reinforcement rib. Tighten all screws with locknuts.

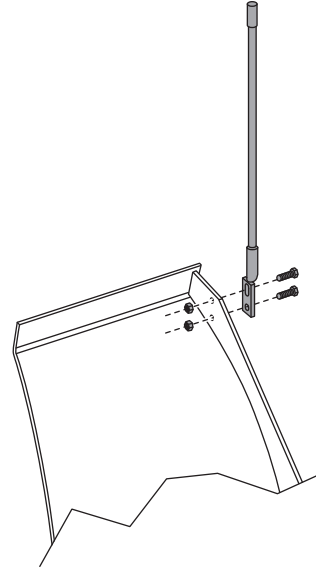

MOLDBOARD & A-FRAME ASSEMBLY

5. Remove the dust cap from both of the hydraulic angle cylinder ports and attach one 7/16" male ORB adapter to each port. Connect the straight end of one 1/4" x 25" hydraulic hose (**B60426**) to each angle cylinder adapter. Be careful not to overtighten the hose connections. Route both hoses through the A-frame access holes, near the angle cylinder mount brackets. Tighten fittings and hoses according to the torque chart.
6. Position each angle cylinder with the rod end of the cylinder in the pivot beam. Secure the cylinders to the pivot beam with a 3/4" x 3-7/16" clevis pin and a 1/4" x 1-1/2" cotter pin. Extend each cylinder rod until the cylinder base mounting hole aligns with the hole on the A-frame angle cylinder bracket. Insert another clevis pin and secure it with a cotter pin.
7. Remove the plastic dust caps from the hydraulic lift cylinder ports. Attach one 7/16" 90° adjustable elbow ORB adapter to the extend port (base end) and one 7/16" male ORB connector adapter to the retract port (rod end). Connect the straight end of the 1/4" x 13-1/2" hydraulic hose (**B60432**) to the rod end adapter. Tighten fittings and hose according to the torque chart.
8. Position the lift cylinder in the channel opening under the A-frame. Route the 13-1/2" rod end hose through the front (closest to the pivot beam) 2" diameter hole in the A-frame. The lift cylinder base end hole should be aligned with the holes on either side of the channel. Secure the lift cylinder to the A-frame using a 5/8" x 5-3/4" clevis pin and one 1/4" x 1-1/2" cotter pin. Use the access hole in the A-frame, located on the driver's side, to install the clevis pin. Connect the 1/4" x 10" hydraulic hose (**B60293**) to the base end adapter. Tighten hose according to the torque chart.

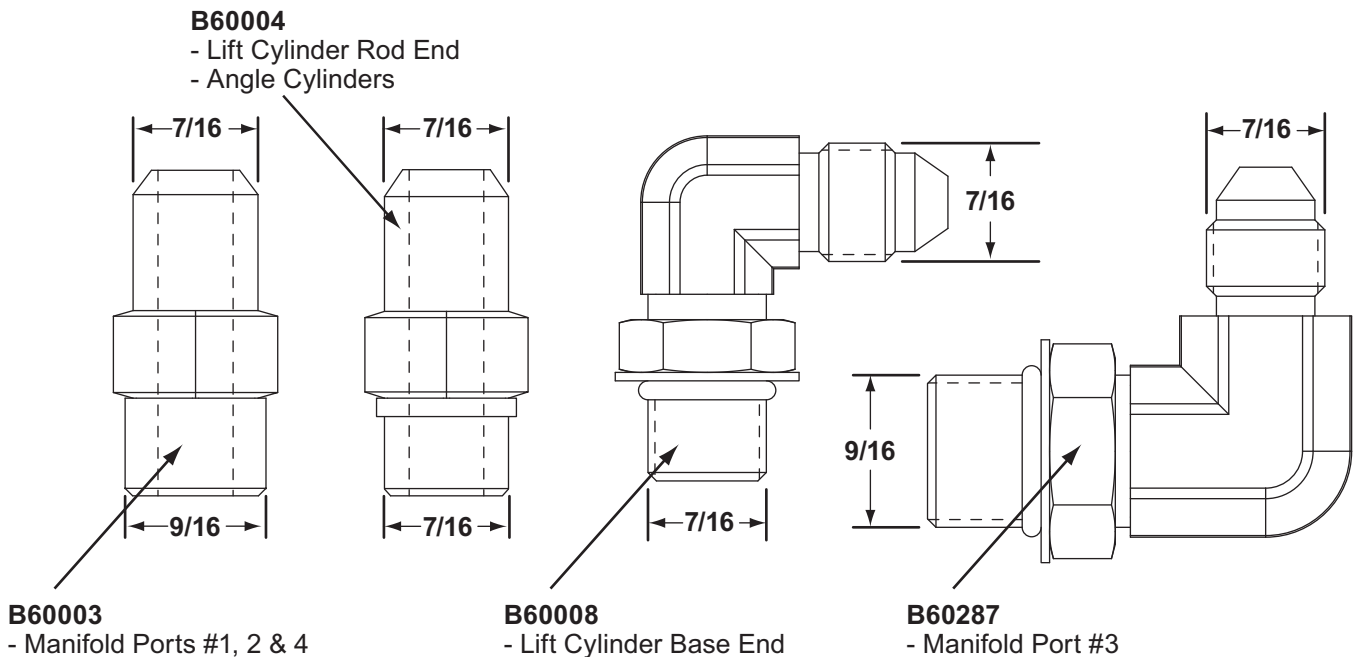

MOLDBOARD & A-FRAME ASSEMBLY

9. Remove the draw latch mount pin, spacer and cotter pin from the draw latch assembly. By removing this pin, the inner draw latch plates can swing free. Remove the inner draw latch plate lift cylinder mount pin. Position the plates on either side of the lift/lower cylinder rod and insert the pin through the plates and cylinder rod. With the cylinder connected to the inner draw latch plates, rotate the draw latch assembly toward the draw latch mount holes on the A-frame. Align the holes in the outer draw latch plate with those of the inner draw latch plates and the A-frame.

NOTE: The A-frame latch, located at the rear/center of the A-frame, should be raised up to insert the draw latch mount pin. Pull the A-frame latch pull pin out and rotate the latch counterclockwise if it is locked into position.

Secure the assembly to the A-frame by replacing the draw latch mount pin, spacer and cotter pin. Reset the A-frame latch so the A-frame latch pull pin locks into place.

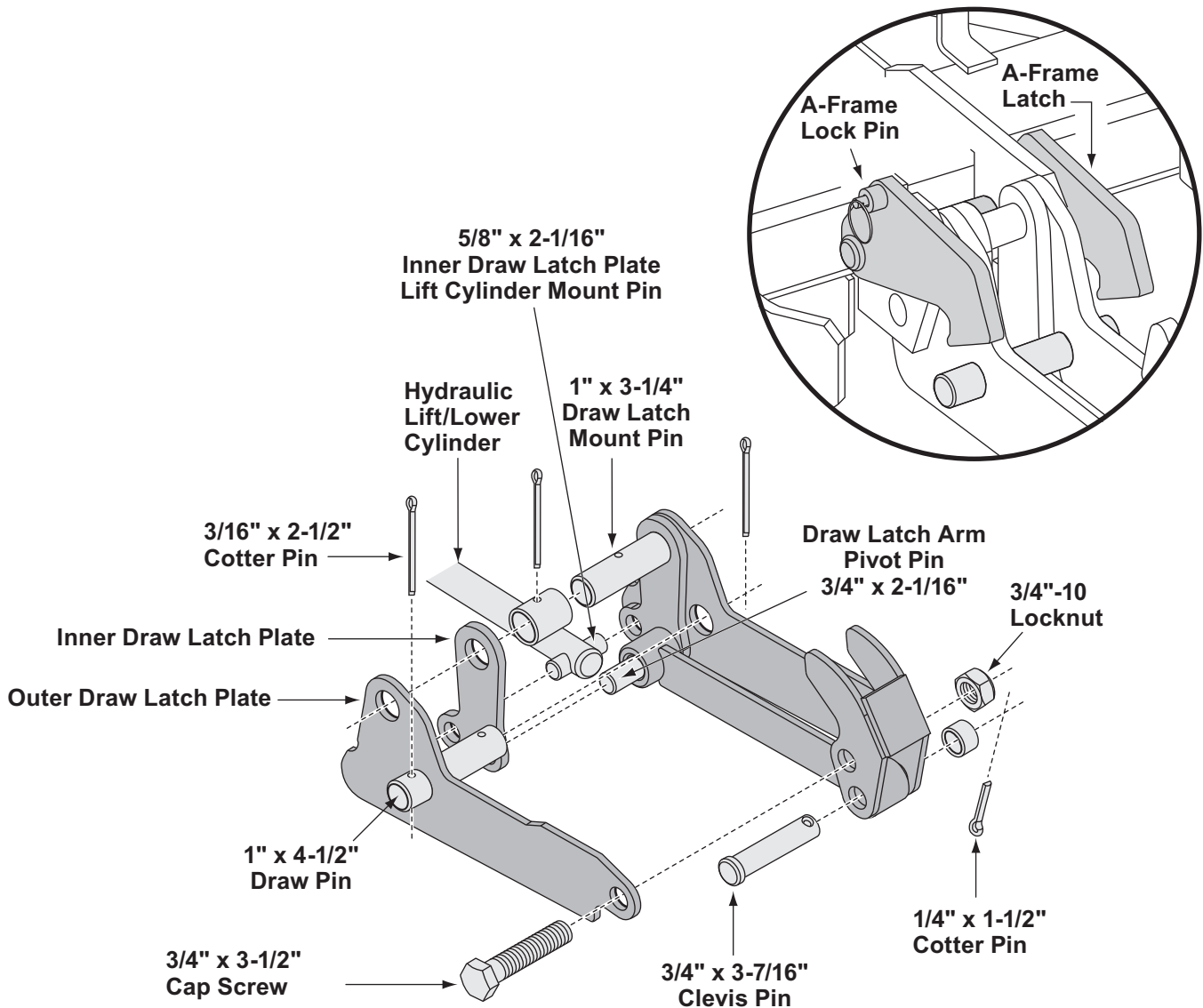

MANIFOLD ASSEMBLY & ELECTRICAL INSTALLATION – SNOWPLOW SIDE

NOTE: The snowplow side electrical harness and connect/disconnect switch must be installed before the manifold is secured.

1. Remove the nut, washer and alignment ring from the POWER HITCH™ connect/disconnect toggle switch and insert it through the back of the mounting bracket on the A-frame. Align the notches on the switch and bracket. Replace the alignment ring, washer and nut and tighten until the switch is firmly in place. Attach the connector on the snowplow harness to the switch.

NOTE: Use caution when connecting, switches can break if done forcefully.

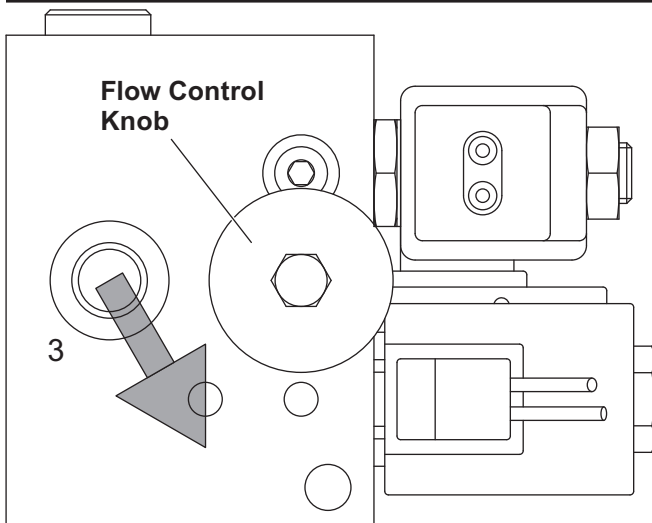

2. Attach the connector on the harness to the connector on the coil harness.
3. Assemble the manifold. The manifold, pump and coil harness have been connected at the factory; however, the manifold contains several components that you will need to install prior to securing the assembly to the A-frame. Each of the hose ports on the manifold is covered with a dust cap. Remove the cap and install the appropriate fitting in its respective port. Tighten fittings and hoses according to the torque chart. Rest the manifold assembly between the mount brackets on the A-frame.

NOTE: The arrow shown on the manifold illustration indicates the direction the 90° adapters should be positioned to receive the hydraulic hoses.

NOTE: The flow control knob will need to be removed to install the fitting into Port #3.

NOTE: DO NOT let any foreign objects enter into the open ports. The valves can become contaminated and greatly hinder the snowplow's performance. Torque to proper specifications.

NOTE: All ports are identified by a stamped number on the manifold. The numbers also identify the hydraulic functions, which can be referenced on the label under the hydraulic pump and manifold cover.

4. Connect the red power wire from the snowplow harness to the pump motor terminal stud. Hardware provided on pump.

NOTE: The red power wire contains an end ring terminal that is too large for the pump motor stud. Remove this terminal and replace it with the 1/4" end ring terminal on the pump motor terminal stud.

5. Align the mount holes in the pump with the holes in the bracket, located on the A-frame. Secure with 3/8" x 1-1/4" cap screw, 3/8" lock washer and 3/8" flat washer through the top mount hole in the bracket and into the pump. Insert 3/8" x 1-1/4" cap screw, 3/8" lock washer and 3/8" flat washer through the bottom mount hole in the bracket and into the pump. This is also the ground location for the snowplow harness.

NOTE: When installing the manifold between the mount brackets on the A-frame, hold the manifold at the sides of the block. Never handle the manifold by the coils. Doing so can cause a solenoid cartridge to bend, causing the cartridge to stick when activated.

MANIFOLD ASSEMBLY & ELECTRICAL INSTALLATION – SNOWPLOW SIDE

6. Remove the bottom bolt, lock washer and flat washer from the rear pump mount bracket. Route the black ground wire (from the harness) under the pump on the driver's side of the A-frame. Align the tooth lock washer and end ring terminal over the hole on the bracket and secure them with the lock washer and bolt.

NOTE: A medium strength thread-locking compound should be used on all of the pump mount fasteners.

7. Secure the manifold to the A-frame. Remove the washers, lock washers and cap screws from the manifold and align the mount holes with the A-frame brackets. Properly replace and tighten all hardware. The passenger-side mount bracket is the ground for the manifold coil harness.

NOTE: A medium strength thread-locking compound should be used to secure the manifold mount fasteners.

8. The manifold contains a red coil wire harness that must be grounded to the A-frame. Secure the 3/8" end ring terminal from this harness to the passenger-side manifold mount bracket with existing manifold mount hardware. The internal/external tooth lock washer provided should install against the mount bracket to provide a solid ground.

**Apply
Thread-Locking
Compound**

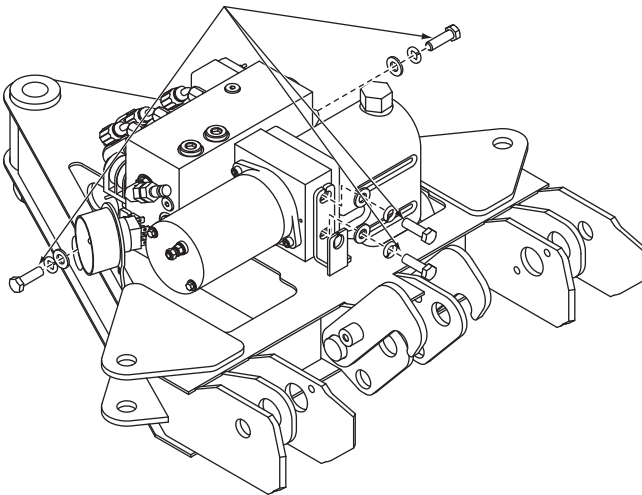

9. Connect the hydraulic hoses to their respective adapters on the manifold. Hose PN B60293 Port #3, Hose PN B60432 Port #4 and Hose PN B60426 Ports #2 and #1. Tighten hoses according to the torque chart.

10. Position the harness braid in the notch on the switch bracket and secure it with a cable tie.

NOTE: The diode loop harness should be inside of the pump cover.

11. Place the power connector, from the harness, through the hole in the pump and manifold cover. Position the cover over the protective toggle switch hood. Align the front and rear holes in the cover with the U-nuts located on the mount tabs. Secure the pump cover with two 3/8" x 1-1/8" knobs.

The pump cover installs over the top of the draw latch switch bracket.

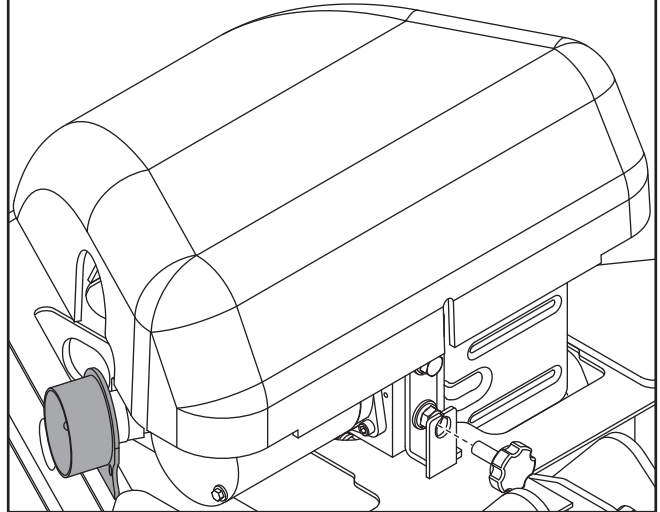

GENERAL SYSTEM SCHEMATICS

B60344 – ELECTRICAL SCHEMATIC

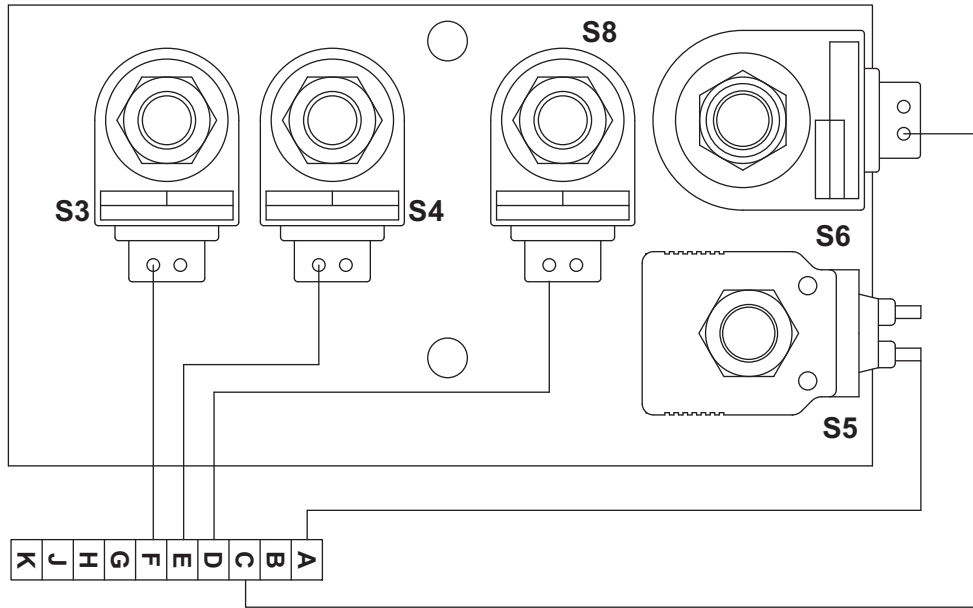

B60344 – HYDRAULIC SCHEMATIC

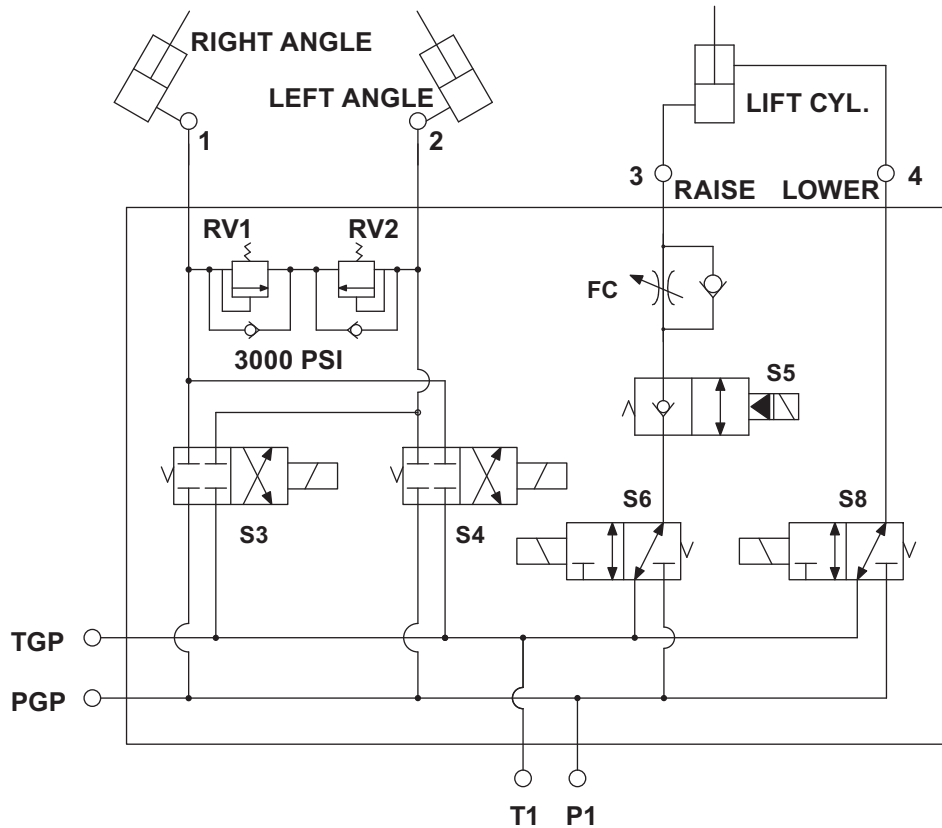

Hydraulic Valve & Hose Port Guide

Models 680LT & 720LT

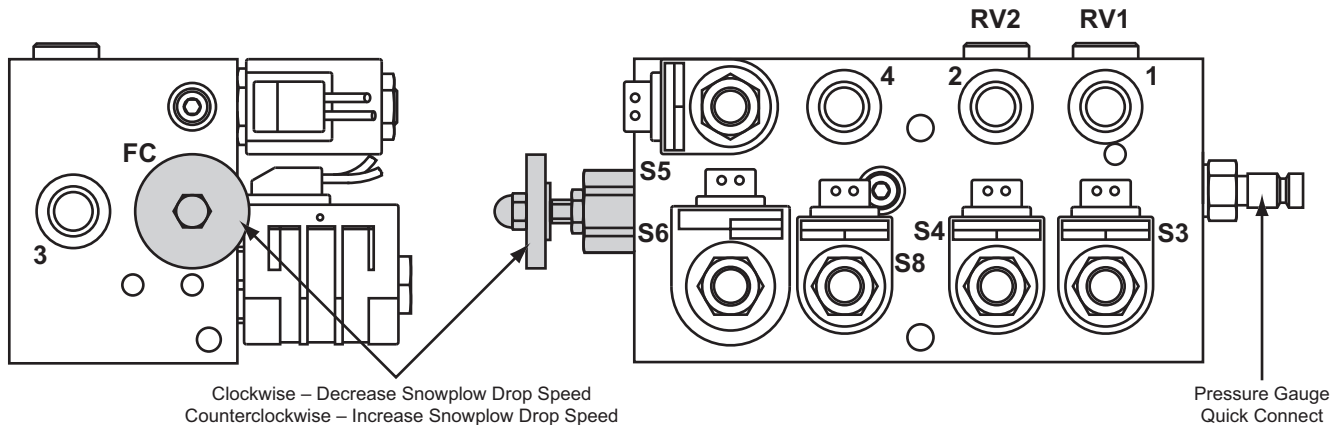

If being used with auxiliary hydraulics, recommended for systems having a flow rated at 4–30 gallons per minute (gpm) and a maximum pressure rating of 3,000psi.

HYDRAULIC HOSES	
Port	Function
1	Angle Right – Driver-Side Cylinder
2	Angle Left – Passenger-Side Cylinder
3	Raise – Lift Cylinder (Base)
4	Lower – Lift Cylinder (Rod)
RELIEF VALVES	
Valve	Function
RV1	Driver-Side Angle Cylinder Relief
RV2	Passenger-Side Angle Cylinder Relief

VARIABLE FLOW CONTROL VALVE	
Valve	Function
FC	Snowplow Drop Speed Adjustment
NOTE: Energize the following solenoids for the functions:	
S3	Angle Left – Passenger-Side Cylinder
S4	Angle Right – Driver-Side Cylinder
S5	Float
S6	Raise – Lift Cylinder (Base)
S5 & S8	Lower – Lift Cylinder (Rod)



Milwaukee, Wisconsin 53224

B63177

ELECTRICAL SCHEMATICS

BLIZZARD® HARNESS PLUG (VEHICLE) UNIVERSAL 14 + 2 MOLD

PIN NO.	COLOR	FUNCTION	AWG
1	BLACK	GROUND	4
	BLACK	GROUND	18
2	RED	12 VOLT DC (+)	4
3	BROWN/WHITE	PUMP SOLENOID TO RING	18
	BROWN	PUMP SOLENOID TO MOLEX	18
4	RED/WHITE	RIGHT SLIDE BOX EXTEND	18
5	RED/BLACK	RIGHT SLIDE BOX RETRACT	18
6	BLUE/WHITE	LEFT SLIDE BOX EXTEND	18
7	BLUE/BLACK	LEFT SLIDE BOX RETRACT	18
8	BLUE	LEFT ANGLE	18
9	LT. GREEN	RIGHT ANGLE	18
10	WHITE	LIFT	18
11	ORANGE	FLOAT	18
12	N/A	N/A	N/A
13	N/A	N/A	N/A
14	N/A	N/A	N/A
15	PINK/BLACK	12 (+) VDC FUSED	18
16	N/A	N/A	18

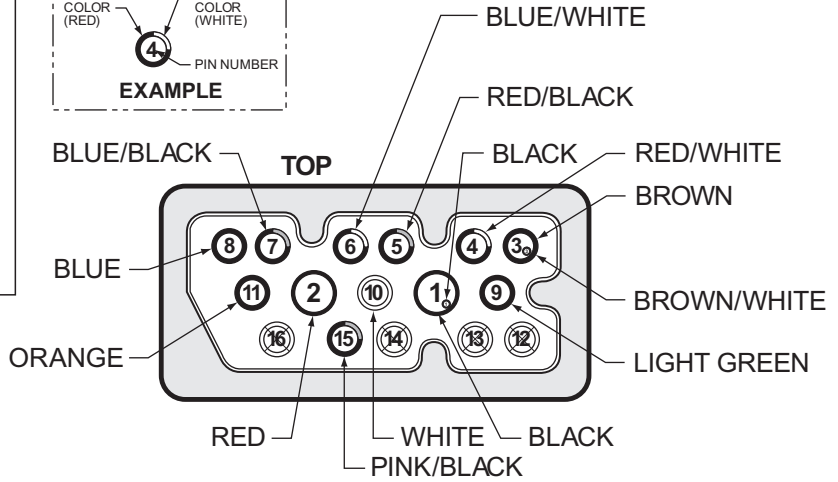
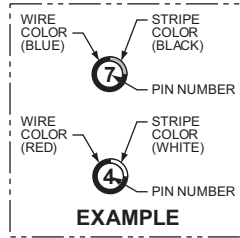
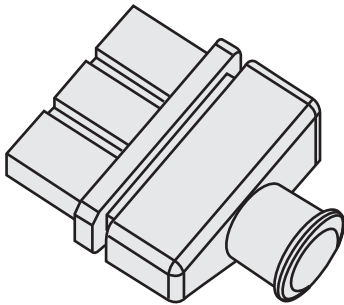

VEHICLE HARNESS PLUG (2005)
FACE VIEW LOOKING AT FEMALE CONNECTOR
FEMALE TERMINALS

BLIZZARD HARNESS PLUG (PLOW)

PIN NO.	COLOR	FUNCTION	AWG
1	BLACK	GROUND	4
	N/A	N/A	N/A
2	RED	12 VOLT DC (+)	4
3	BROWN	PUMP SOLENOID	18
4	RED/WHITE	RIGHT SLIDE BOX EXTEND	18
5	RED/BLACK	RIGHT SLIDE BOX RETRACT	18
6	BLUE/WHITE	LEFT SLIDE BOX EXTEND	18
7	BLUE/BLACK	LEFT SLIDE BOX RETRACT	18
8	BLUE	LEFT ANGLE	18
9	LT. GREEN	RIGHT ANGLE	18
10	WHITE	LIFT	18
	WHITE	LIFT	18
11	ORANGE	FLOAT	18
12	N/A	N/A	N/A
13	N/A	N/A	N/A
14	N/A	N/A	N/A
15	PINK/BLACK	12 (+) VDC FUSED	18
16	N/A	N/A	18

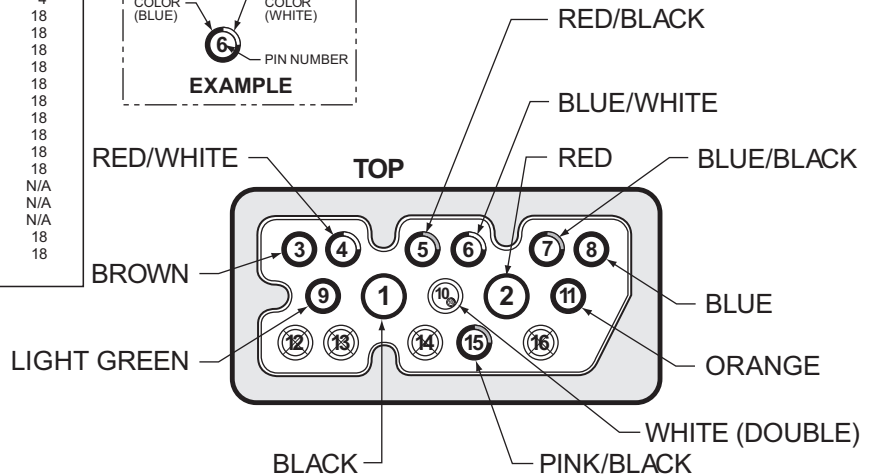
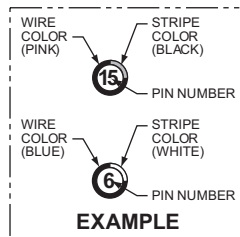
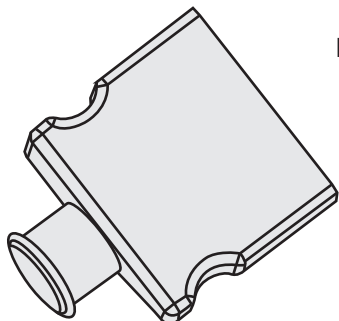

PLOW HARNESS PLUG (2005)
FACE VIEW LOOKING AT MALE CONNECTOR
MALE TERMINALS

ELECTRICAL SCHEMATICS – SNOWPLOW SIDE

PLOW HARNESS (B62039)

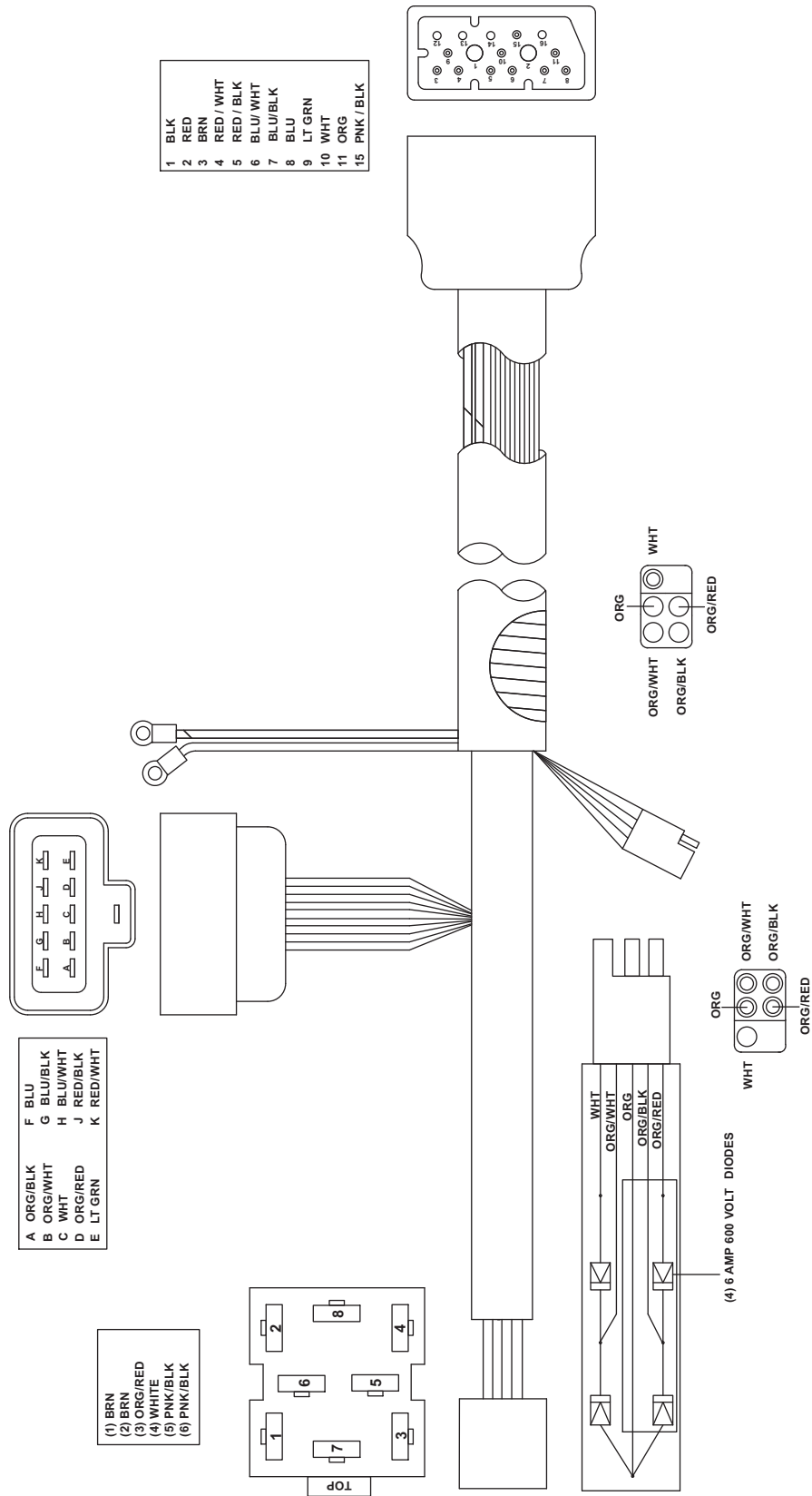

ELECTRICAL SCHEMATICS – SNOWPLOW SIDE

PLOW WIRE HARNESS SCHEMATIC (B62039)

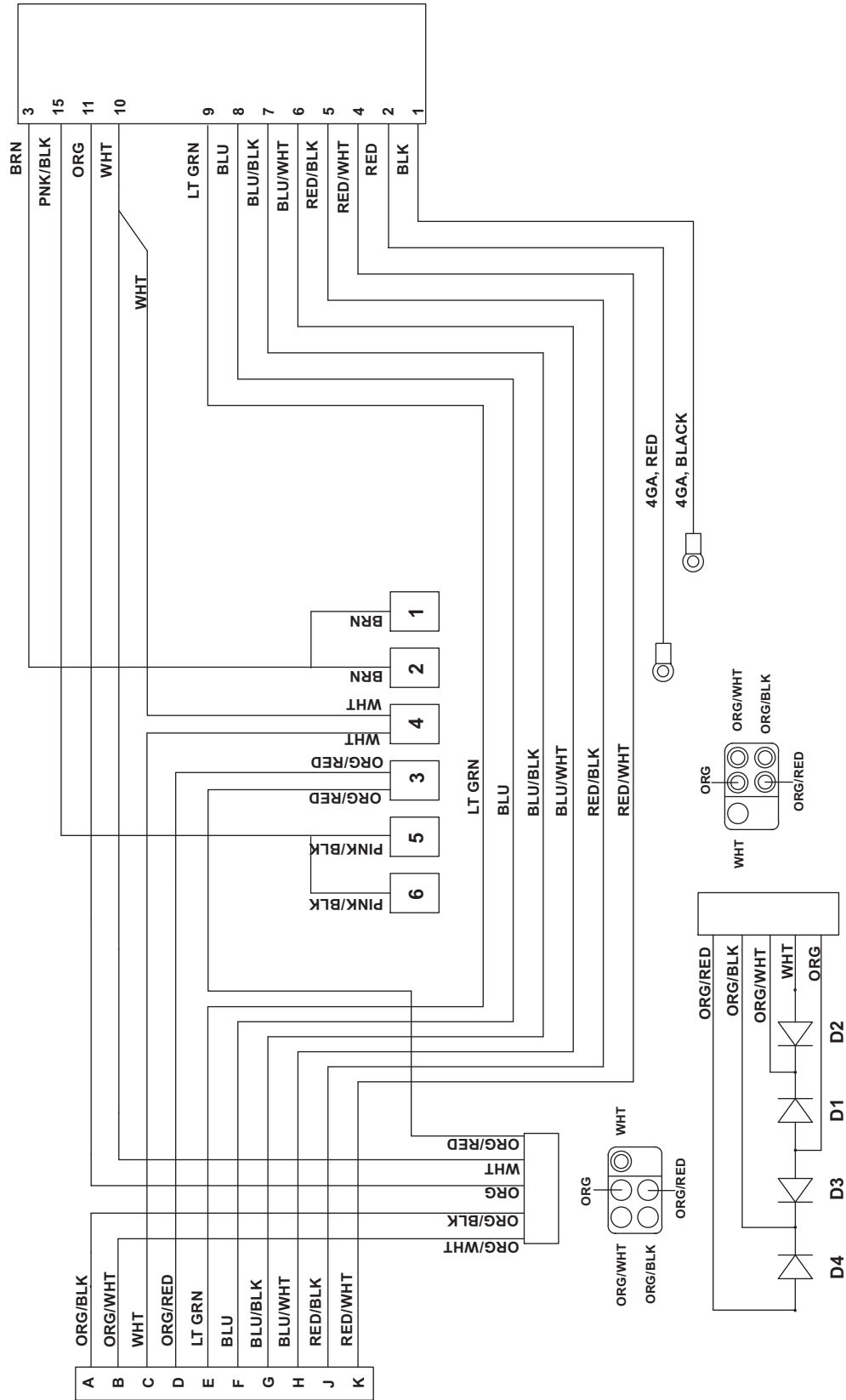

ELECTRICAL INSTALLATION – VEHICLE SIDE

⚠ CAUTION

Before drilling any holes, check the selected area for wires, hoses or other obstructions.

1. With the large plug on the electrical harness placed near the tow hook, under the bumper, route the harness over the driver-side fender well and to the fire wall. Insert the connector end of the harness through an existing hole in the fire wall and into the vehicle cab. If an access hole does not exist, drill an appropriately sized hole through the fire wall in a convenient location away from sharp edges and hot or moving parts.

NOTE: Keep the snowplow plug and vehicle connector pins lubricated with a liberal amount of dielectric grease. Always replace the protective weather caps when the snowplow is disconnected from the vehicle.

2. Attach the power contactor (solenoid) to the driver's side wheel well or engine fan guard using #12 x 3/4" self-drilling screws.

NOTE: Some model vehicles provide mounting locations for accessory components.

Always mount the solenoid with the terminals facing up, for extended solenoid life. Connect the 24" black ground wire to either small terminal on the solenoid and attach the opposite end to the vehicle with a self-drilling screw. Cut the brown/white pump activation wire on the harness to length. Strip the end of the harness, and crimp the eyelet terminal onto it. Attach the eyelet to the remaining small terminal on the contactor. Secure it with the hardware provided on the solenoid.

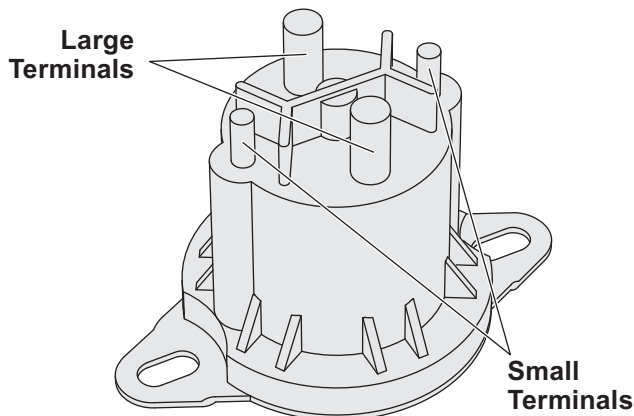

NOTE: Do not fasten the harness to areas that come in contact with moving engine parts or possess extreme heat. The harness could become tangled and/or melt causing electrical failure and vehicle damage.

3. Connect the vehicle harness ground wire to the NEGATIVE (-) terminal on the vehicle's battery. Cut the wire to length, and strip the end of the wire. Crimp and solder a 3/8" ring terminal on the wire.

NOTE: The harness should be secured to the vehicle prior to taking the necessary measurement.

Measure the distance needed for the power wire to reach the solenoid. Strip the wire, then crimp and solder an end ring terminal to it. Connect the power wire to either large terminal on the solenoid.

4. Strip both ends of the remaining length of red wire, then attach and solder an end ring terminal to both. Connect one end of the wire to the open terminal on the solenoid and the remaining end to the POSITIVE (+) terminal on the battery.
5. Position the main lighting harness with both of the truck headlamp connectors near each truck headlamp and the snowplow headlamp connectors near the grille of the vehicle.
6. Plug the headlamp ground/relay connector from the vehicle harness into the connector on the main lighting harness. Securely mount the relay receptacles to the vehicle with the terminal wires facing down and the relays facing up. Installing the relays in this position will allow moisture to drain from the relay.
7. Remove the front signal lamp assembly from both sides of the vehicle. On the driver's side, feed the violet (turn lamp) and gray (run lamp) wires from the main lighting harness through the opening in the signal lamp housing. Use a test light or ohmmeter to determine the proper wires in the vehicle's electrical system to splice into. Position

ELECTRICAL INSTALLATION – VEHICLE SIDE

one end of the turn or run lamp wire into the splice lock connector, and attach the vehicle wire into the opposite side. Complete the splice by pinching both wires together and locking the connector. Repeat the splice procedure for the remaining wire.

8. Repeat Step 7 for the passenger's side using the pink (turn lamp) and gray (run lamp) wires.
9. Connect the vehicle headlamps to the main lighting harness using a light conversion harness kit. Due to differences in the construction of the kits, and the various make and model vehicles BLIZZARD® snowplows are installed on, a light conversion kit is not packaged with your snowplow. Contact your local BLIZZARD dealer to obtain the appropriate conversion harness kit for your vehicle.
10. Secure the braided harness to the vehicle. Safely route all harnesses around the engine components and attach them to the vehicle with cable ties. Extend the snowplow headlamp connectors, from the main lighting harness, through the grille of the vehicle and position the harness power plug and weather cap near the bumper. Cable tie the plug to the vehicle bumper or tow hook to keep the harness from hanging too low.

⚠ CAUTION

Do not alter, modify or install additional components in shaded areas of the following illustration. Failure to comply may interfere with air bag deployment or cause injury to operator in an accident.

11. Install the remainder of the vehicle wire harness to the interior of the cab. Find an accessible location for the snowplow headlamp toggle switch and bracket under the dashboard. When choosing a location for your switch, it should be mounted in easy reach of the vehicle operator and not restricting access to vehicle controls or vehicle

instrumentation. Do not mount the switch in areas prohibited by the vehicle manufacturer for crash worthiness. See the vehicle's body builder's book, owner's manual or service manual for details. The shaded areas in the illustration below show the most commonly restricted areas.

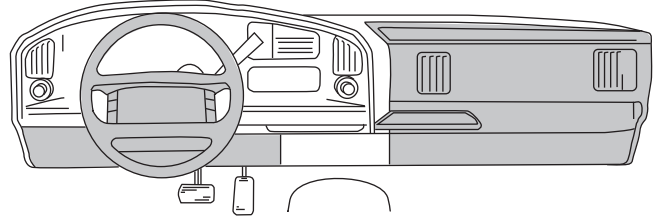

Install the headlamp bracket using two self-drilling screws. Insert the toggle switch through the bracket and secure it with the hardware provided. Plug both of the switch leads into the toggle switch.

NOTE: Both terminals should be inserted into the spades on the same side of the switch. One terminal should be positioned in the middle spade.

Plug both 2-pin connectors together and this will connect the toggle switch to the vehicle wire harness. See illustration below.

12. Connect the power wire (with 15 amp fuse) to a switched power source with a minimum of 15 amps.

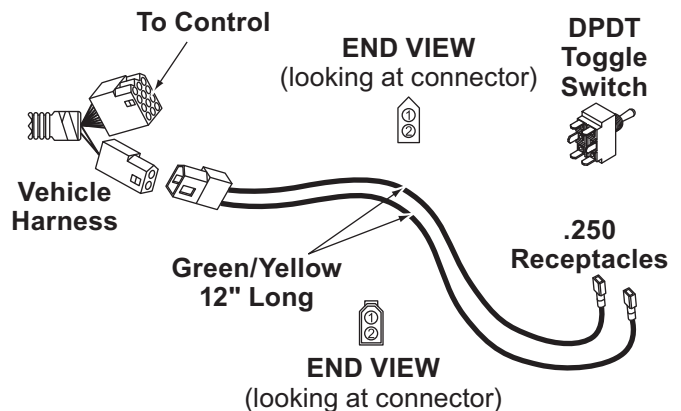

ELECTRICAL INSTALLATION – VEHICLE SIDE

NOTE: The red power wire MUST be fused and switched ON and OFF with ignition.

Secure all loose wires under the dash.

13. Install the light tower. Position the arms into the receiving pockets located on the undercarriage. Each pocket has a lock pin that secures both light tower arms. Pull out and twist each handle to temporarily unlock the pins. Place the light tower into the pockets and re-lock the pins. See your local BLIZZARD® dealer for complete installation instructions for your vehicle undercarriage.
14. Install the snowplow headlamps. Align one headlamp stud on the light tower tube with the mounting hole and insert the threaded stud through each. Secure the headlamp with one 1/2" galvanized washer (neoprene facing up), one 7/16" external tooth lock washer and locknut.

NOTE: All snowplows are shipped with two caps that install on the ends of the light tower.

After adding a liberal amount of dielectric grease, connect the terminals from the snowplow headlamps to the terminals on the main lighting harness.

15. **If using a joystick control**, align the mount holes on the joystick control with the holes located on the mount pedestal.

NOTE: The radius on the pedestal should face the dashboard.

Secure the joystick to the pedestal with the 8 x 3/4" machine screws provided. Slide the hook-and-loop fastener strap through the slots cut in the pedestal. The D-ring should be located on the side opposite of the radius. Wrap the strap around the bench and fasten.

16. Connect the white power connector from the vehicle wire harness to the connector on the control station. The power switch should be in the "OFF" position.

NOTE: The operation of the draw latch can only be controlled when the switch on the control is in the "POWER HITCH™" position and the "RAISE/LOWER" rocker switch on the A-frame is in the neutral (center) position.

17. After completing the mechanical and electrical installations, test all snowplow and lighting functions before attempting to drive or plow.

Joystick Control

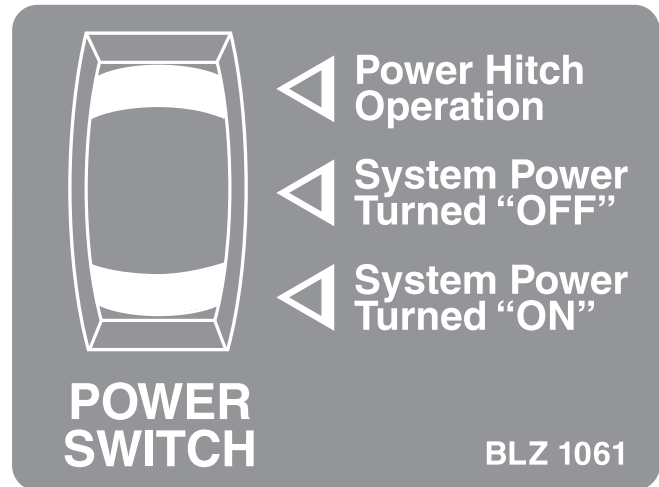

Touchpad Control

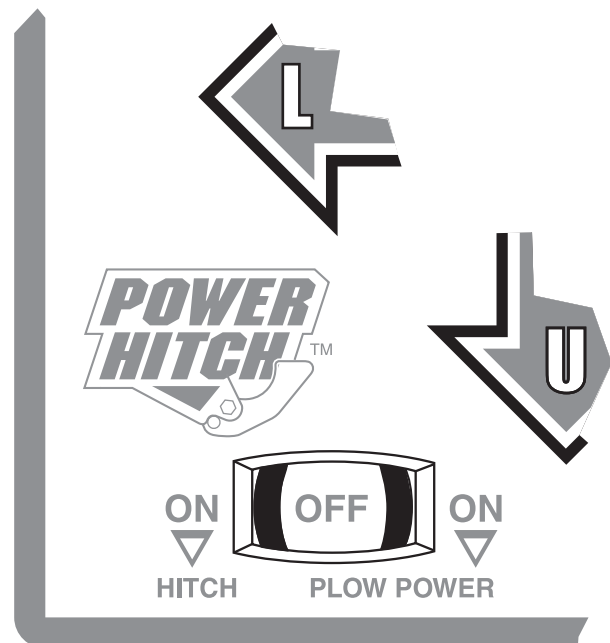

ELECTRICAL SCHEMATICS – VEHICLE SIDE

VEHICLE HARNESS (2005)

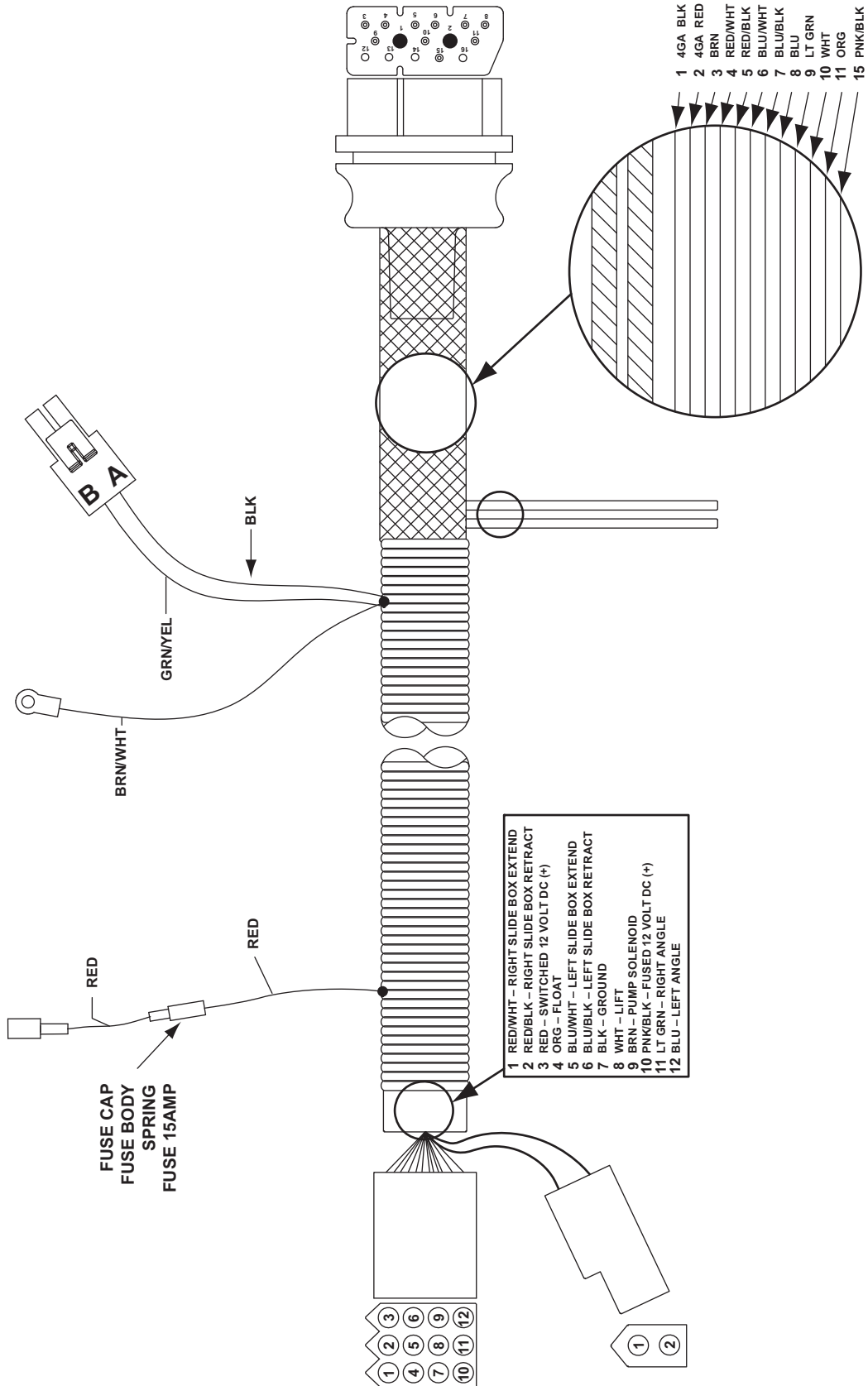

ELECTRICAL SCHEMATICS – VEHICLE SIDE

VEHICLE HARNESS SCHEMATIC (2005)

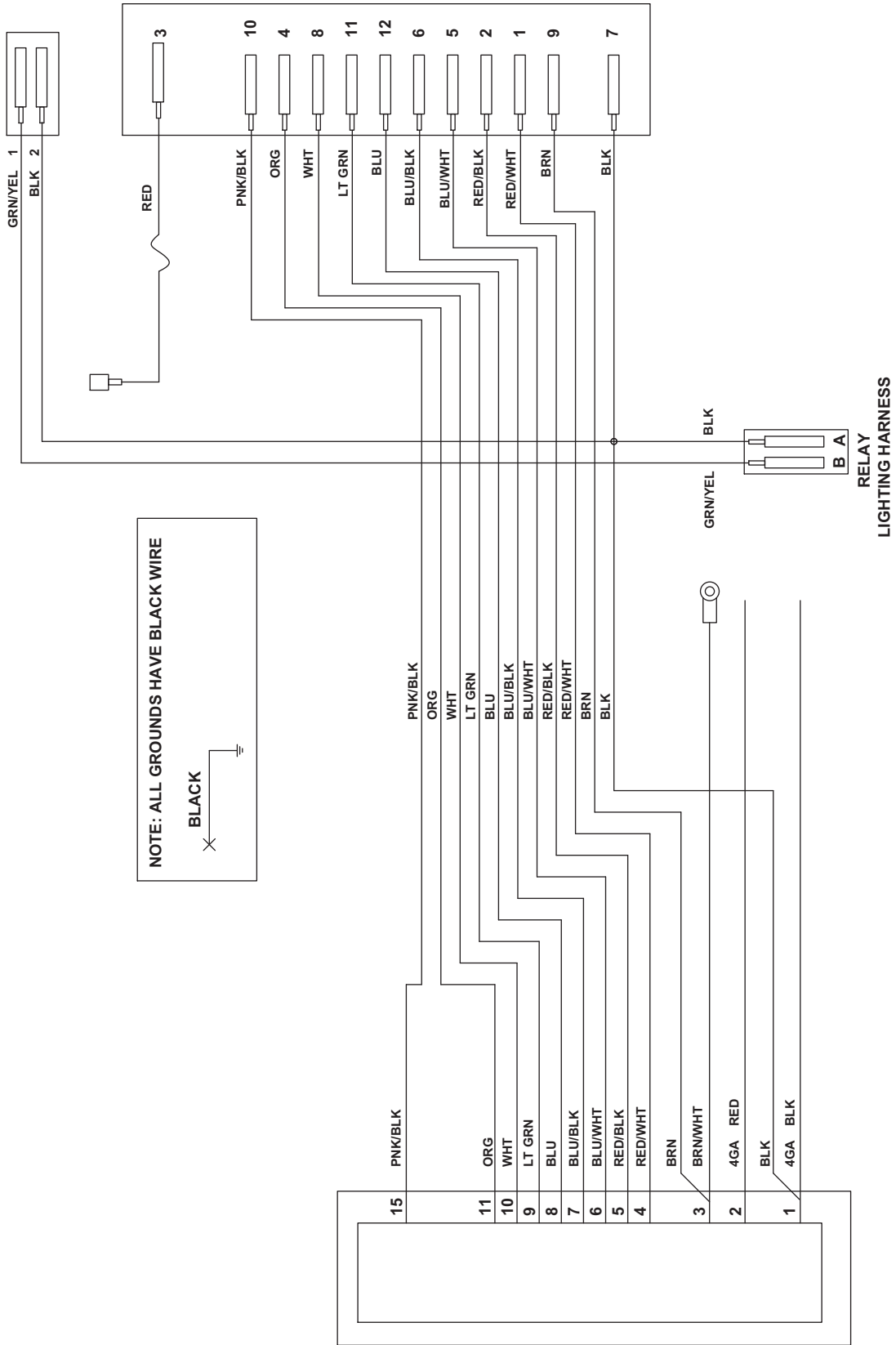

ELECTRICAL SCHEMATICS – VEHICLE SIDE

MAIN LIGHTING HARNESS (2005)

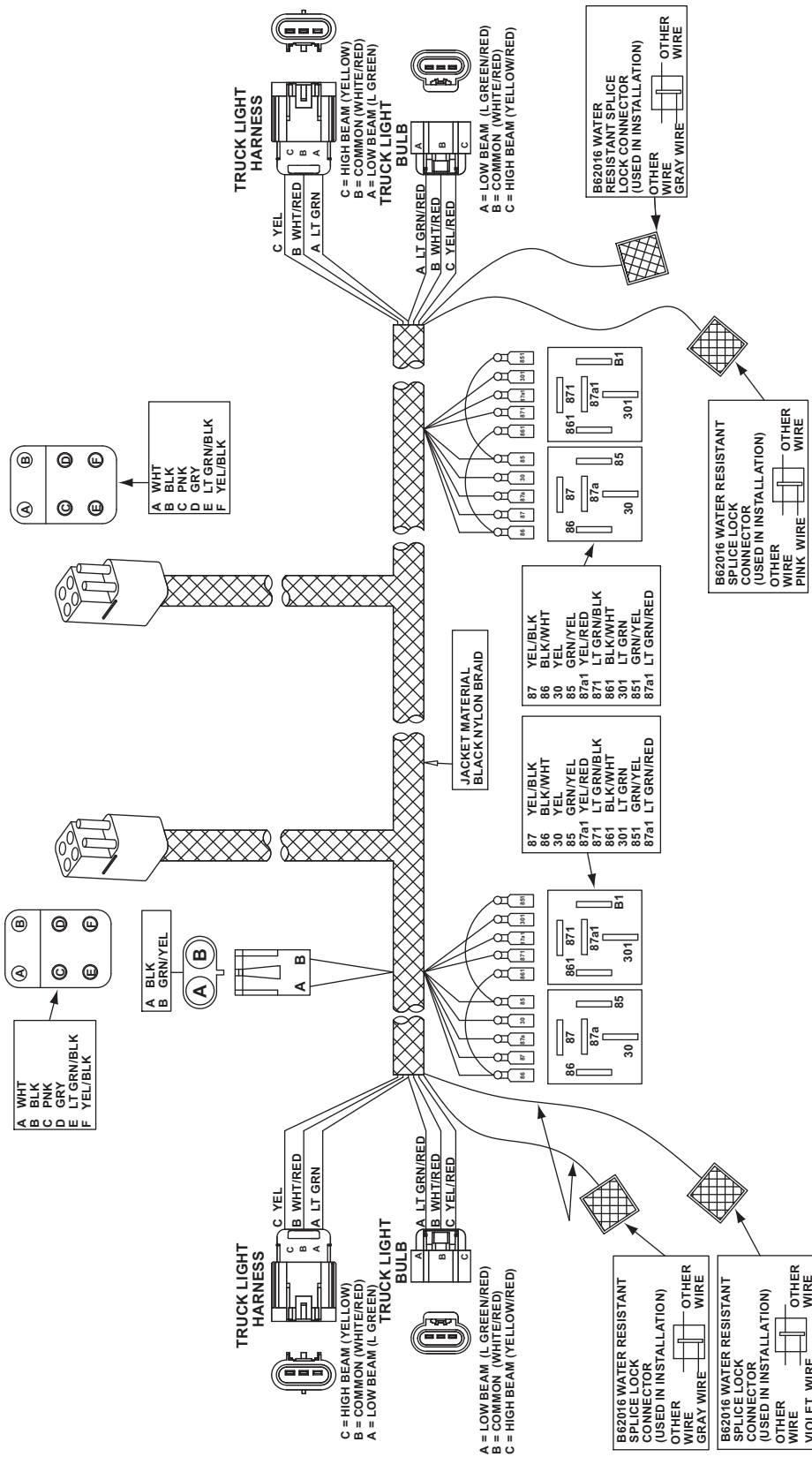

ELECTRICAL SCHEMATICS – VEHICLE SIDE

MAIN LIGHTING HARNESS SCHEMATIC (2005)

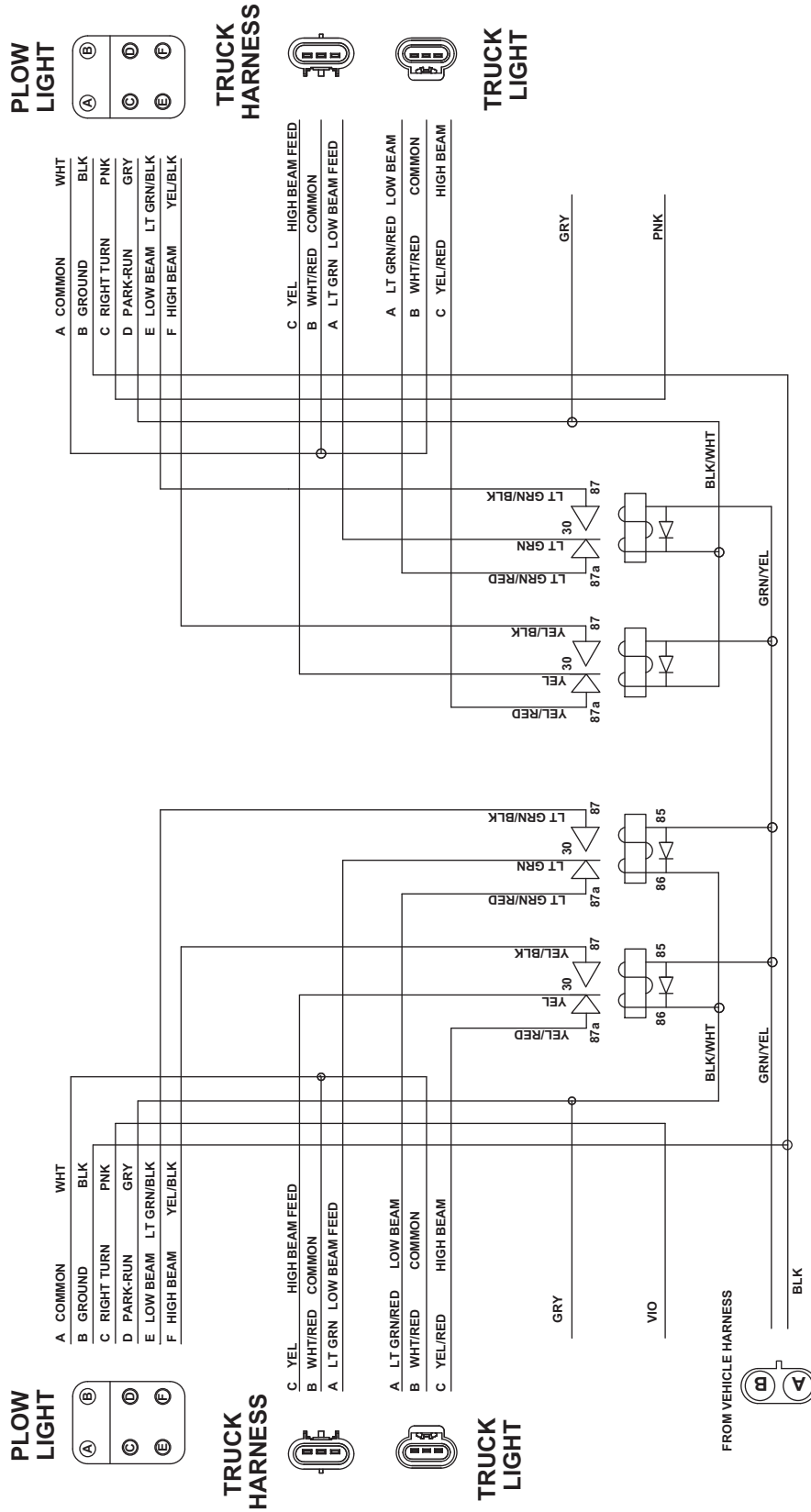

POWER HITCH™ SYSTEM INSTRUCTIONS

Prior to operating your straight blade snowplow, review the Mounting and Dismounting Instructions label on the back of the driver-side moldboard.

NOTE: If at any time the Mounting and Dismounting Instructions label, or any other label attached to your snowplow becomes illegible, promptly replace them.

MOUNT INSTRUCTIONS

Read Owner's Manual for Complete Instructions.

STEP #1

⚠ WARNING: Keep fingers away. POWER HITCH arm raises behind undercarriage pushbeam.

- Kickstand must be lowered, with kickstand pin seated in lower hole on pivot beam.
- Slowly drive vehicle forward until pushbeam receiver mount points contact A-frame mount bushings.
- Turn POWER HITCH OPERATION switch (on plow control) to "ON" position.
- Connect plow and vehicle electrical harnesses. Connect weather caps together.

DISMOUNT INSTRUCTIONS

Read Owner's Manual for Complete Instructions.

STEP #1

⚠ WARNING: Keep fingers away from plow and truck mounting points.

- Raise plow. Lower kickstand until kickstand pin is seated in lower hole on pivot beam.
- Lower plow on flat, level surface. Turn vehicle ignition off.
- Remove hitch pins from A-frame and undercarriage.
- Turn vehicle ignition on.
- Turn POWER HITCH OPERATION switch (on plow control) to "ON" position.

STEP #2

- Pull A-frame latch lock pin out and lower A-frame latch over draw pin.
- Push and hold CONNECT/DISCONNECT switch upward. POWER HITCH arm will engage back of pushbeam and pull plow into pushbeam receiver mount points on vehicle.
- Insert both hitch pins and secure each with hair pin cotter.
- Lower POWER HITCH arm to relieve tension on A-frame latch. Raise A-frame latch and lock into position with lock pin. Raise plow.
- Raise kickstand until kickstand pin seats into upper hole on pivot beam.

STEP #2

- Push and hold CONNECT/DISCONNECT switch downward. POWER HITCH arm will disengage from behind undercarriage pushbeam and lower.
- Disconnect plow and vehicle electrical harnesses. Install weather caps.
- Turn SYSTEM POWER (on plow control) to "OFF" position.
- Slowly move vehicle backward away from plow.

U.S. Patents 5,638,618; 5,899,007; 6,178,669; 6,276,076; 6,393,737; 6,408,549; 6,412,199; 6,442,877; 6,615,513; Canadian and other patents pending.

44812

TESTING YOUR SNOWPLOW

1. Fill the hydraulic pump reservoir with BLIZZARD® Snowplow Rapid Action Hydraulic Fluid until it is approximately 3/4" from the top of the tank. Replace the cap on the reservoir. Remove the weather caps from each of the snowplow and vehicle harnesses and connect the plugs. Start the vehicle and turn the power switch on the control station in the cab to the "ON" position.

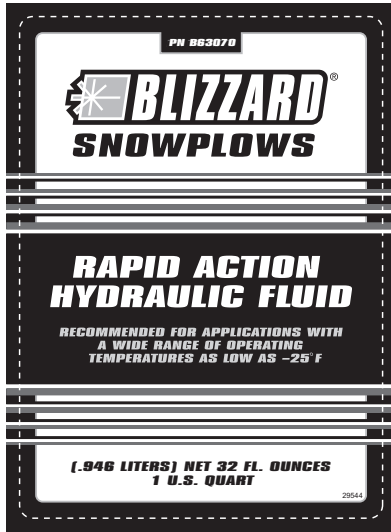

⚠ WARNING

You can die or be seriously injured. Keep hands and feet away from hitch mechanism and snowplow blade when operating the POWER HITCH™ arm. The action of the arm moves the snowplow toward the vehicle and into position for proper attachment.

2. To raise the POWER HITCH arm on the snowplow, turn the power switch on the control station to the "UP" or "ON" position. Push and hold the toggle switch on the A-frame upward into the "CONNECT" position. Notice the action of the fluid in the reservoir. By activating the initial hydraulic function, the fluid begins to fill the system. Push and hold the toggle switch in the "DISCONNECT" position, the POWER HITCH arm will lower. Refill the reservoir until the fluid is approximately 3/4" from the top of the tank.

3. Align the POWER HITCH arm on the A-frame below the pushbeam, with the receiver plates in line with the receiver plates on the undercarriage. Pull out the A-frame latch pin and rotate the A-frame latch clockwise until the latch is resting on the draw pin. Move the snowplow in position by activating the POWER HITCH connect switch and release.

The POWER HITCH arm will rise until it hits the pushbeam and the draw latch fingers will pull the snowplow into the vehicle. The receiver plates on the snowplow and vehicle are now positively aligned. Insert the two hitch pins through the mounting holes on the A-frame and secure each with one hair pin cotter.

After the two hitch pins are inserted through the A-frame, lower the POWER HITCH arm using the toggle switch on the A-frame. Rotate the A-frame latch counterclockwise until the A-frame latch lock pin can be reinserted. Fully reinserting the A-frame latch lock pin will lock the A-frame latch in place for transport or plowing snow. (See below.)

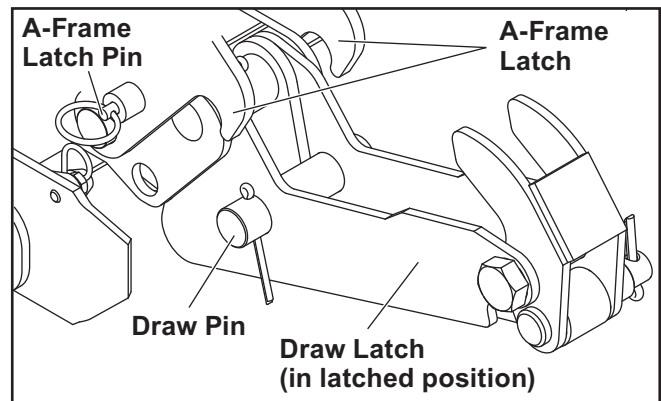

4. Return to the interior of the vehicle. Test the remaining functions of the snowplow. The system power on the control should be in the "ON" position. Raise the snowplow to its maximum height by pulling the joystick back (or down) or pressing the U button on the touchpad. Angle the snowplow to the left by moving the joystick toward the "L" (left angle) on the label or pressing the L button on the touchpad. If the snowplow function

TESTING YOUR SNOWPLOW

is slow or delayed, the hydraulic fluid is filling the cylinder and replacing the air in the system. Test the remaining functions of the snowplow. To lower the snowplow to the ground, push the joystick ahead (or up) or push the D button on the touchpad.

NOTE: The FLOAT function is activated when the joystick is pushed ahead (or up) into the "LOWER" position or the D button is pressed on the touchpad and held there for an additional .5 sec after the blade contacts the ground. The LED float light (touchpad only) will come ON when the snowplow is in FLOAT mode.

Angle the snowplow to the right by moving the joystick toward the "R" (right angle) on the label or pressing the R button on the touchpad. Check the fluid level in the reservoir and fill to 3/4" from the top of the tank if needed.

5. Check for fluid leaks around the manifold, pump, hydraulic hoses and all cylinders. If there are any leaks, turn OFF the power switch on the control and shut OFF the vehicle engine. Then, tighten any loose connections and/or fittings. Restart the vehicle, cycle all blade controls, then check to see if all the leaks have been stopped after shutting OFF the control power switch and shutting down the vehicle.
6. Check that the vehicle and snowplow headlamps are in proper working condition including the turn signals.

(No LED Float Light or Indicator Light)

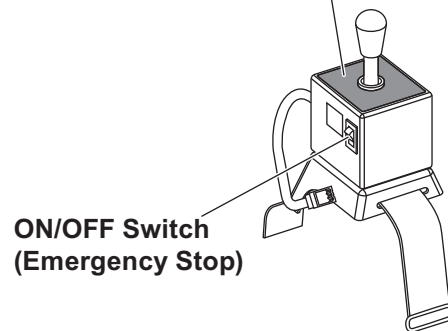
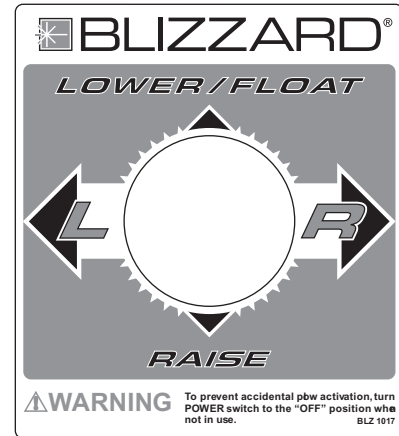

LED Float Light

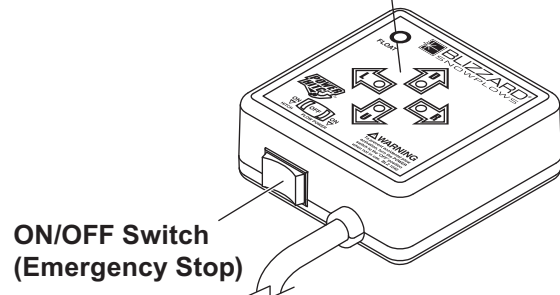
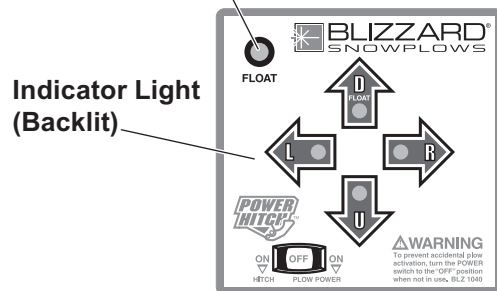

HEADLAMP AIMING

Fully tighten headlamp fasteners once correct visual aim is achieved.

1. Place vehicle on a level surface 25 feet in front of a matte-white screen, such as a garage door. The screen should be perpendicular both to the ground and to the vehicle centerline.
2. The vehicle should be equipped for normal operation. The snowplow blade should be in place and in raised position. Below are steps listed by the Society of Automotive Engineers (SAE) pertinent to headlamp aiming in specification #SAE J599d.
3. Prepare vehicle for headlamp aim or inspection. Before checking headlamp aim, the inspector will:
 - a. Remove ice or mud from under fenders.
 - b. Set tire inflation pressures to the values specified on vehicle information label.
 - c. Check springs for sag or broken leaves.
 - d. See that there is no load in the vehicle other than the driver and ballast as specified in the Undercarriage Selection Guide.
4. Mark (or tape) the vertical centerline of the snowplow headlamps and the vertical centerline of the vehicle on the screen. Mark the horizontal centerline of the snowplow headlamps on the screen (distance from ground to snowplow headlamp centers).
5. Align the top edge of the high intensity zone of the snowplow lower beam below the horizontal centerline and the left edge of the high intensity zone on the vertical centerline for each snowplow headlamp. (Refer to diagram below.)

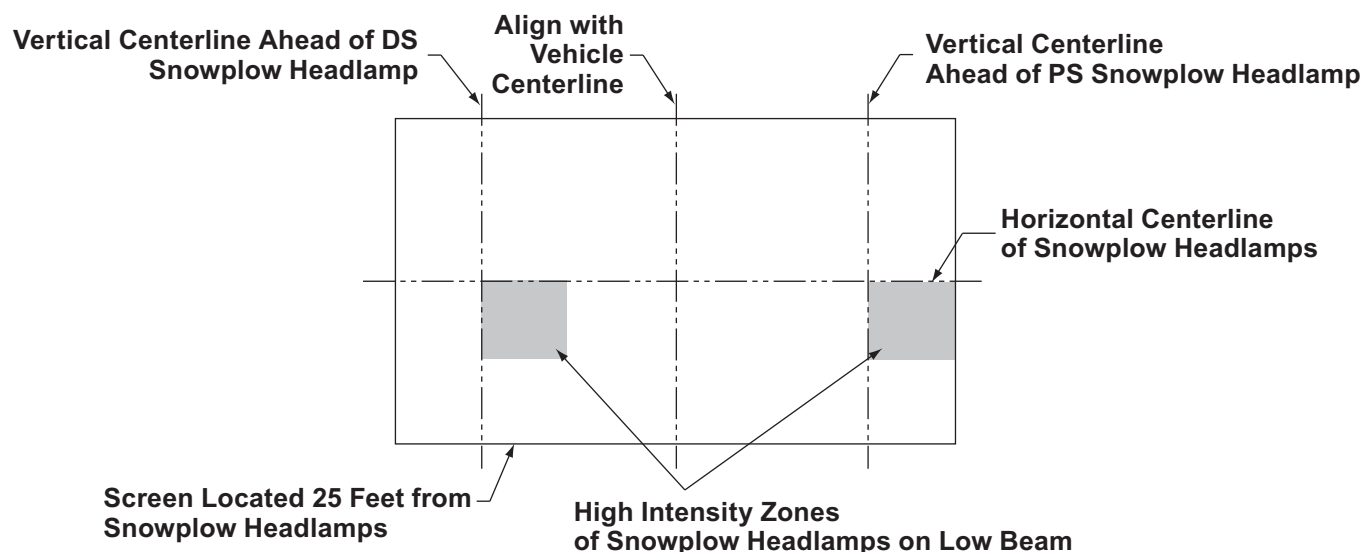

MAINTENANCE

Maintenance	Periodically	Yearly
Check fasteners for tightness. Torque to specifications.	X	
Check hoses for wear and leaks.	X	
Check cylinders for leaks, inspect rod ends for corrosion and pitting.	X	
Lubricate all exposed cylinder rod ends with liquid white lithium grease to prevent corrosion.		X
Check cutting edges and plow shoes for wear. <i>NOTE: Do not discard plow shoe washers, these should be retained for different shoe adjustments.</i>	X	
Clean and lubricate all electrical plugs and connections with dielectric grease. Clean and install all dust caps prior to storing.	X	X
Lubricate all pins and bushings, and A-frame latch with NLGI Grade 2 multi-purpose lithium complex grease with molybdenum (MPGM) to maintain consistent operation.	X	X
Clean and paint all scratches or exposed metal with BLIZZARD® touch-up paint.	X	X
Check the hydraulic fluid level. Fill with fluid to 3/4" from the top of the reservoir. Do not exceed this level. Never mix different types of fluid.	X	
Remove and properly discard the fluid from the pump reservoir. Clean the pump filter and replace the hydraulic fluid to within 3/4" from the top of the reservoir. Changing the fluid annually will prolong the life of your pump and manifold. Never mix different types of hydraulic fluid.		X
Check the trip spring adjustment. Properly adjusted tension will allow a sheet of paper to pass between the 3rd and 4th coils of the spring.	X	
Clean snow and ice build-up from the pump and manifold cover.	X	
Pressure wash and dry the entire snowplow prior to storing.		X
Cover the snowplow with a tarp if stored outside. This will protect your snowplow from sun fading and inclement weather which can lead to accelerated corrosion.		X

REMOVING FROM STORAGE

1. Perform all regular maintenance.
2. Replace the hydraulic fluid in the pump reservoir. Prolonged storage could result in condensation build-up.
3. Follow the mounting procedure on the POWER HITCH™ label.
4. Initiate all of the functions. Monitor the fluid level in the reservoir and fill to 3/4" from the top of the tank as necessary.
5. Adjust the snowplow headlamps as needed.

LIFTING

To lift and move this snowplow, attach chain fall grab hooks to outside pivot beam area shown. Always follow recommended lift warnings and procedures. See following page for snowplow weights and dimensions.

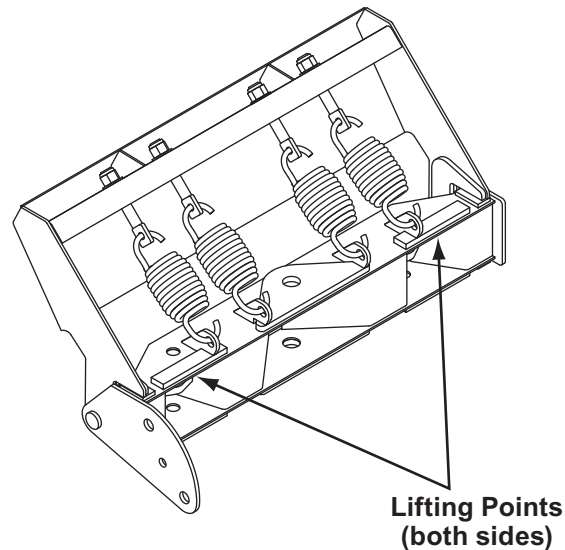

TECHNICAL SPECIFICATIONS

Part	Specification	680LT	720LT
Moldboard	Length	80" (6'-8")	86" (7'-2")
	Thickness	14 ga	
	Height	21-1/2"	23-1/2"
	Reinforcement	4 Ribs @ 3/16"	
	Cutting Edge (1080)	1/4" x 5"	
	Finish	Powder Coat White	
	Trip Mechanism	(4) 5/16" Hooked Extension	
A-Frame	Material	Rectangular Tube and Channel Type	
	Hitch Pins	3/4" x 6" Yellow Zinc	
	Finish	Powder Coat Black	
Pump	Construction	Steel Housing w/Clear Plastic Tank	
	Type	Internal Gear Pump	
	Size	0.7cc	
	Motor	12V Starter	
	Weight	32 lb	
	Mount	A-frame Install w/Hex Cap Screws	
	Reservoir Capacity	2 qt	
	Controls	Toggle and Rocker Switch/Joystick or Touchpad	
Manifold	Construction	Red Anodized Aluminum	
	Valves	Electro-Hydraulic Cartridge	
Cylinders	Angle Cylinders	2	
	Stroke	7-5/16"	
	Ram Diameter	1-1/4"	
	Bore Diameter	1-1/2"	
	Raise/Lower Cylinders	1	
	Stroke	4-5/8"	
	Ram Diameter	1"	
	Bore Diameter	1-3/4"	
Snowplow Headlamps	Type	Low Profile w/Turn Signals	
	Measurements	12" W x 5" H x 5-1/4" D	
	Housing	Plastic Composite	
	Bulb Type	High/Low Sealed Beam Halogen 12V Rectangular	
	Switch Type	Dash Mount, Toggle	
Snowplow Specs	Weight*	361 lb	375 lb
	Amperage Draw**	65A (Approximately)	
	Adjustable Plow Shoes	(2) Std.	
	Mount Mechanism	Hydraulic Power Switch	
	Control Station	Joystick or Touchpad	

* Weight does not include undercarriage.

** Amperage Draw specifications are based on snowplow lift operation, at a shop temperature of 65°F, using BLIZZARD® Rapid Action Hydraulic Fluid. Amperage will vary with temperature, fluid viscosity and meter accuracy. Deadheading a snowplow function will result in significantly increased amperage.

TROUBLESHOOTING

Problem	Cause	Solution
Pump will not run.	Snowplow harness may not be properly connected to the vehicle harness.	Verify the harnesses are properly connected.
	Power or ground cables to the battery, pump or solenoid may not be properly connected.	Properly connect all cables. Clean and lubricate with dielectric grease. If power does not resume, check the continuity of all cables to find the break.
Pump will not run, power to the solenoid.	The black ground wire and brown/white activation wire on the solenoid are not properly connected.	Properly connect both cables. Test for power by initiating any control function except FLOAT. <i>NOTE: The POWER rocker switch must be in the "ON" position to properly test any snowplow function.</i> If the solenoid is grounded and no power exists, diagnose the snowplow and truck harnesses.
Pump will not run with power to the solenoid. Brown/white activation wire and ground are properly connected.	The red, hot wire to the pump motor is not properly connected.	Connect red wire and check the black ground wire. If problem is not resolved, the solenoid could be inoperable or the pump motor may be worn. Replace the solenoid if there is no power to the pump. Replace the pump motor if it is receiving power.
Pump will not turn OFF. Do not allow the pump motor to run continuously. Unplug the harness until the solenoid can be tested or a BLIZZARD® outlet can diagnose the problem.	Solenoid may be damaged.	Disconnect the brown/white activation wire from the solenoid. If the problem is not resolved, replace the solenoid.
	Short in the control or wire harness.	Disconnect the control in the cab. If the pump turns OFF, there is a short in the electrical system.
Pump runs but snowplow functions are slow.	Fluid level in the pump reservoir is low. Fluid is leaking.	Add fluid to within 3/4" from the top of the tank. Check for leaks around the pump, manifold and cylinders.
	Amperage from the vehicle's alternator is too low.	Repair or replace vehicle alternator. System amperage draw is 65A at 1500 psi.
	Pump filter may be clogged.	Remove the pump tank and thoroughly clean the filter.
A-frame latch will not move.	Draw latch is binding the A-frame latch.	Lower the draw latch to relieve binding on the A-frame latch and reposition the A-frame latch as needed.
Snowplow will not lift. Pump works properly.	Control station in the cab may not be properly connected.	Connect the power connector from the control to the vehicle harness.
	A-frame latch is in the (down) locked position.	Lift the A-frame latch into the raised position.
	Diode loop harness may be corroded or could have failed.	Clean diode loop harness thoroughly and/or replace.
	Coils on the manifold may be damaged.	Remove the S6 coil from the cartridge valve. Position a screwdriver inside of the coil and push the draw latch connect/disconnect toggle switch upward. The screwdriver should be magnetically drawn to the coil. Replace the coil if there is no action.
Snowplow will not lift with magnification to the S6 coil.	Hydraulic lock in the manifold. This occurs if the voltage is too low on the coils—should be 11.8 volts.	Loosen cartridge valve S6 to relieve pressure and retighten. DO NOT OVERTIGHTEN! Valves should be torqued to a maximum of 24 ft-lb.
	Solenoid cartridge valve may be contaminated.	Remove any foreign objects that may be obstructing proper valve operation. Replace if not operating properly after cleaning.

TROUBLESHOOTING

Problem	Cause	Solution
Snowplow will not stay angled when plowing.	The angle pressure relief valve is set too low. <i>NOTE: Increasing the pressure relief valve will cause damage to your snowplow. Do not set the pressure relief greater than 3000 psi.</i>	Check the pressure relief by testing the valve in-line with the cylinder. Attach a tee fitting to the angle cylinder hydraulic adapter and connect the hose and pressure gauge to the tee. <i>NOTE: The setting should not exceed 3000 psi.</i>
Snowplow will not angle, pump works.	Review all probable causes above.	<i>NOTE: Verify coils S3 and S4 for angle functions.</i>
Snowplow lowers too slowly.	Variable flow control valve is not adjusted properly.	⚠ WARNING: Snowplow can fall suddenly. You can die or be seriously injured. Drop snowplow to ground before adjusting flow control. Turn flow control valve counterclockwise in small increments and test.
	Review all probable causes for snowplow will not lift.	Verify S5 coil (float) or S5 and S8 coils (disconnect) for magnetism.
Snowplow drops sporadically.	Variable flow control valve is opened too far.	⚠ WARNING: Snowplow can fall suddenly. You can die or be seriously injured. Drop snowplow to ground before adjusting flow control. Turn clockwise 1/16 turn and test.
Headlamps will not switch from the vehicle to the snowplow.	No power or ground to the headlamp relay.	Verify the headlamp/ground relay connector is connected. If the connector is properly attached replace the headlamp relay(s).

MOLDBOARD PARTS – ALL MODELS

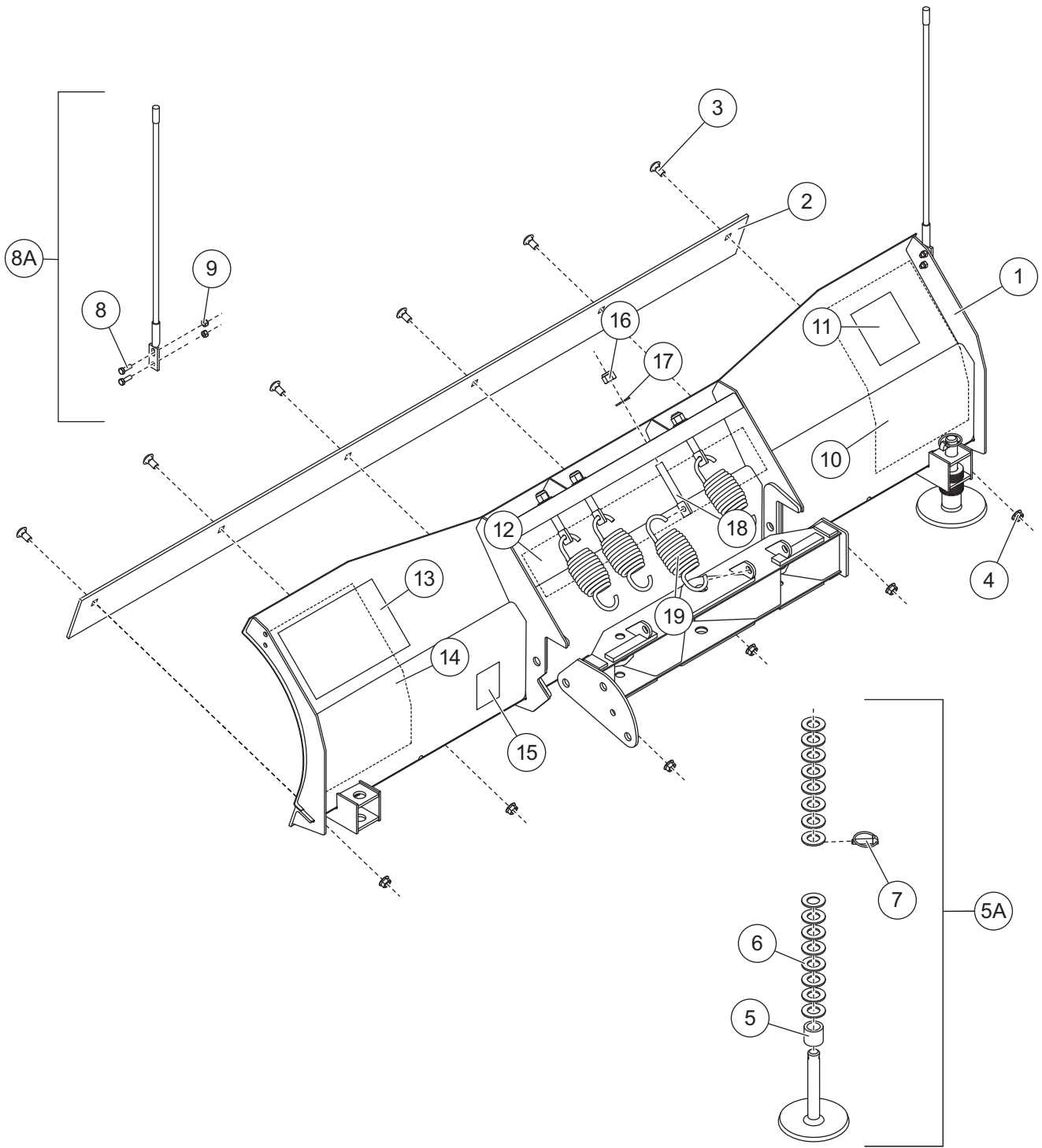

MOLDBOARD PARTS – ALL MODELS

Item	Part	Qty		Description
		680LT	720LT	
1	B81061	1	–	Moldboard
	B81067	–	1	Moldboard
2	B81062	1	–	Cutting Edge
	B81073	–	1	Cutting Edge
3	B61196	6	6	1/2-13 x 1-1/2 Carriage Bolt G8
4	B61365	6	6	1/2-13 Flanged Hex Locknut
5A	B61098	2	2	Plow Shoe Assy Standard (7-3/4 Shaft) (Incl. Items 5–7)
5	60045	2	2	1-1/8 ID, 1-5/8 OD x 1-1/2 Spacer
6	91192	36	36	1" Flat Washer
7	93010	2	2	7/16 x 1-3/4 Linchpin
8A	B61049	1	1	Plow Guide Assy (Incl. Items 8 & 9)
8	68494	4	4	5/16-18 x 1 Hex Cap Screw G5
9	91332	4	4	5/16-18 Hex Locknut GB Topping
10	B63102	1	–	Decal – PS
	B63110	–	1	Decal – PS
11	59900	1	1	Label – Warning/Caution
12	B63164	1	1	Decal, Center Moldboard (BLZ 1074)
13	44812	1	1	Label – POWER HITCH™ Mounting & Dismounting
14	B63103	1	–	Decal – DS
	B63111	–	1	Decal – DS
15	29256	1	1	Label – Crush Hazard
16	91337	4	4	5/8-11 Hex Locknut Type NE
17	90576	4	4	5/8 Hardened Washer
18	B61201	4	4	5/8-11 x 4-3/8 Spade Bolt, G8
19	B61435	4	4	6-7/8 OAL x 2-3/4 OD x 5/16 Extension Spring
G = Grade				

A-FRAME & PIVOT BEAM PARTS – ALL MODELS

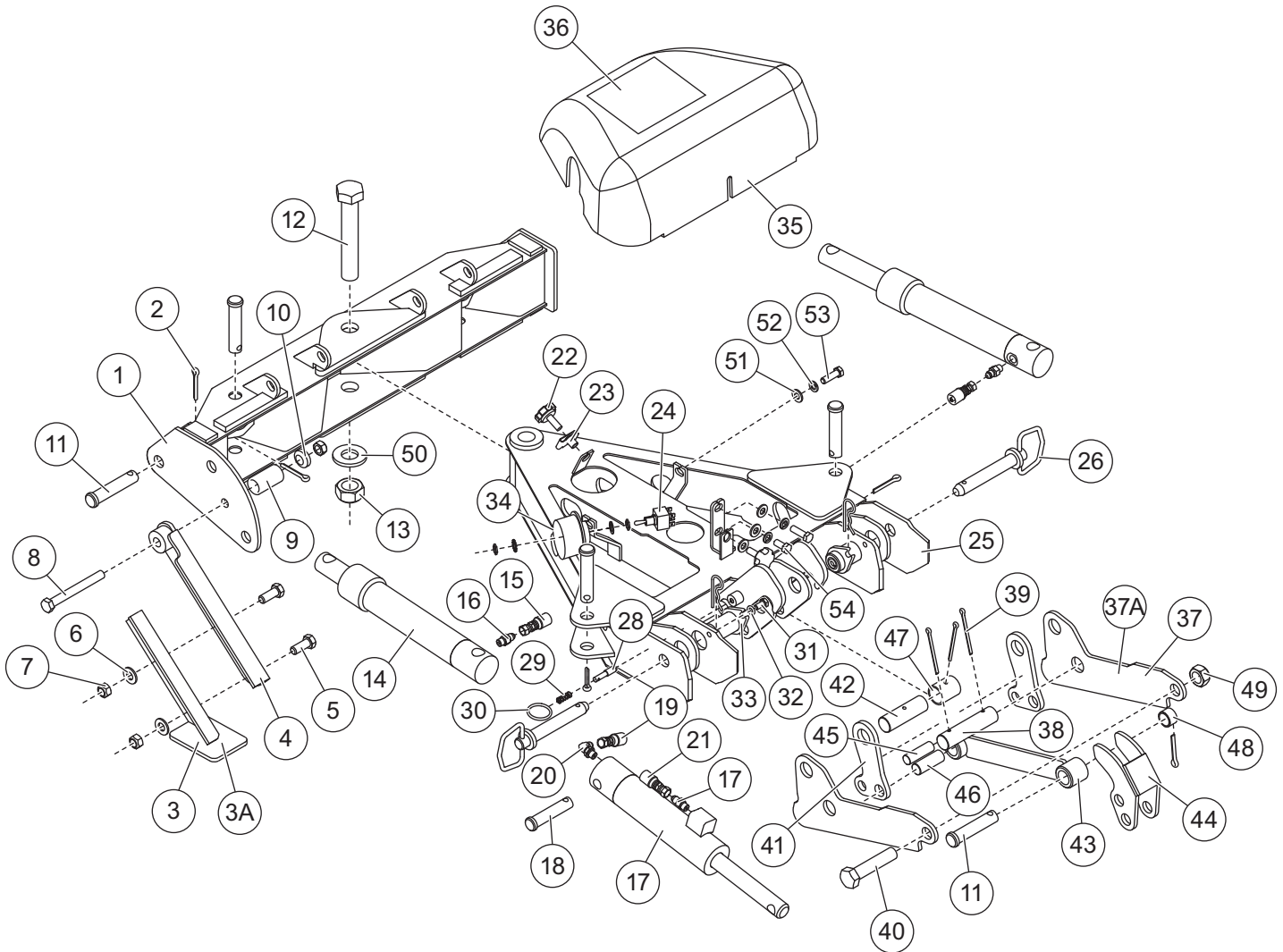

Item	Part	Qty	Description
1	B83017	1	Pivot Beam
2	90601	8	1/4 x 1-1/2 Cotter Pin
3A	B41039	1	Kickstand Assembly (Incl. Items 3–10)
3	B41047	1	Kickstand Foot
4	B41038	1	Kickstand Leg
5	90665	2	1/2-13 x 1-1/4 Hex Cap Screw G8
6	90572	2	1/2 Hardened Flat Washer
7	90593	3	1/2-13 Hex Locknut GC
8	42009	1	1/2-13 x 4-1/2 Hex Cap Screw G8
9	B61293	1	1-1/8 OD x 53/64 ID x 2 Compression Spring
10	B41037	1	3/8 x 1-1/8 OD x 35/64 ID Stepped Bushing
11	B82055	7	3/4 x 3-7/16 Clevis Pin
12	B61434	1	1-8 x 6 Hex Cap Screw (4-3/4 Shank) G8
13	B61008	1	1-8 Top Locknut GC Distorted Thread
14	B60277	2	Hydraulic Cylinder, Plow Angle
			G = Grade
			SS = Stainless Steel

A-FRAME & PIVOT BEAM PARTS – ALL MODELS

Item	Part	Qty	Description
15	B60426	2	1/4 x 25 45° Hydraulic Hose Plow Angle Left and Right Cylinder
16	B60004	3	7/16-20 Hydraulic Adapter Male ORB
17	B60254	1	Hydraulic Cylinder, Plow Raise/Lower
18	B82061	1	5/8 x 5-3/4 Clevis Pin
19	B60293	1	1/4 x 10 Hydraulic Hose Raise/Lower, Extend (Base End)
20	B60008	1	7/16-20 90° Adjustable Elbow Hydraulic Adapter ORB
21	B60432	1	1/4 x 13-1/2 45° Hydraulic Hose Raise/Lower, Retract
22	B61438	2	3/8-16 x 1-1/8 Clamping Knob
23	B61275	2	3/8-16 U-Nut
24	B62038	1	DPDT (ON)-OFF-(ON) 16 Amps 115V AC Toggle Switch
25	B82109	1	A-Frame
26	B61426	3	3/4 x 6 Hitch Pin
27	B61105	3	9/64 x 2-11/16 Hair Cotter Pin
28	B40079	1	3/8 x 1-3/4 Pin SS
29	B61000	1	0.94 OAF L x 0.36 OD, 0.029 Wire Compression Spring SS
30	B61309	1	Ring, Standard Split SS
31	90018	4	5/16-18 x 5/8 Hex Cap Screw G5
32	B61011	4	5/16 Split Lock Washer High-Alloy
33	B40126	2	A-Frame Pivot, Replaceable Bushing
34	B61295	1	Label – POWER HITCH™ Connect/Disconnect Switch (BLZ 1037)
35	B82108	1	Cover, Hydraulic Pump and Manifold
36	B63177	1	Label – Hydraulic Hose Identification Guide (BLZ 1087)
37A	B82087	1	Draw Latch Assy (Incl. Items 37–49, 2 [1])
37	B82084	2	Outer Draw Latch Plate – DS and PS
38	B82101	1	1 x 4-1/4 Draw Pin
39	B61363	3	3/16 x 2-1/2 Cotter Pin
40	B61308	1	3/4-10 x 3-1/2 Hex Cap Screw G8
41	B82088	2	Inner Draw Latch Plate
42	B82095	1	1 x 3-1/4 Draw Latch Pin Mount (To A-frame)
43	B82092	1	Draw Latch Arm
44	B82091	1	Draw Latch Finger
45	B82096	1	5/8 x 2-1/16 Inner Draw Pin Latch Plate/Hydraulic Cylinder Rod End
46	B82097	1	3/4 x 2-1/16 Draw Pin Latch Arm Pivot
47	B40093	1	1-1/4 OD, 1-1/16 ID x 1-1/2 Bushing
48	B40116	1	1 OD, 25/32 ID x 5/8 Spacer
49	B61006	1	3/4-10 Hex Locknut GC
50	B61203	1	1" Washer
51	29233	4	3/8 Hardened Flat Washer
52	91203	4	3/8 High Alloy Split Lock Washer
53	90055	3	3/8-16 x 1-1/4 Hex Cap Screw G8
54	90097	1	3/8-16 x 3/4 Hex Cap Screw G8
			G = Grade
			SS = Stainless Steel

POWER UNIT PARTS – ALL MODELS

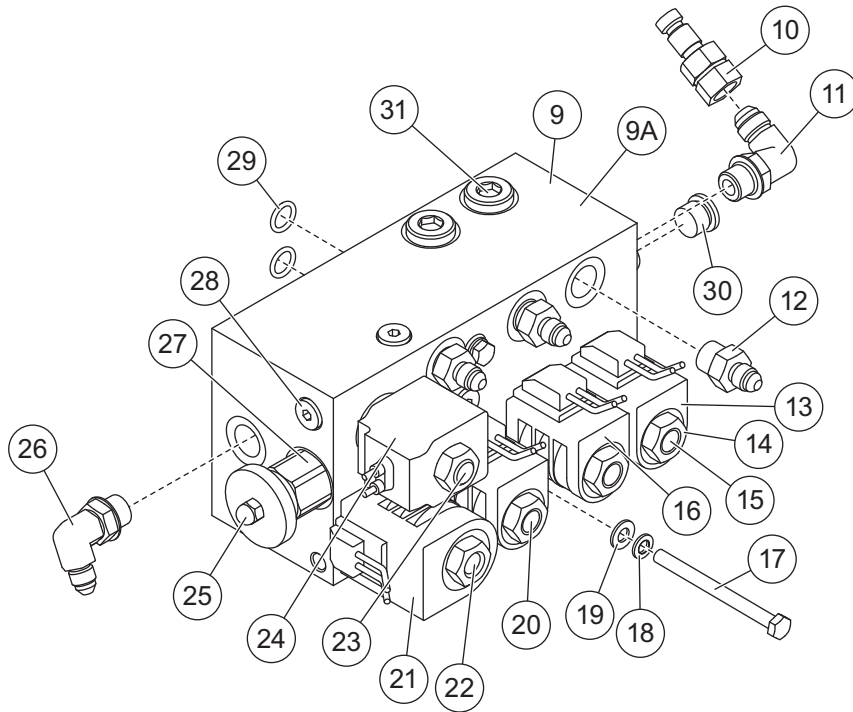
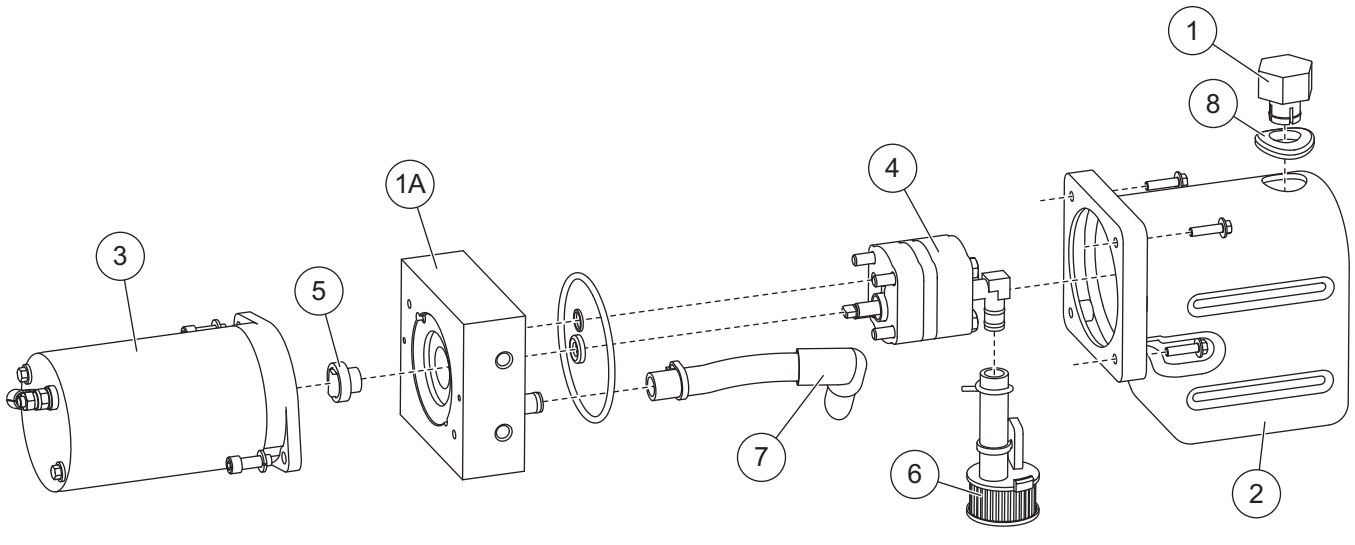

POWER UNIT PARTS – ALL MODELS

Item	Part	Qty	Description
ns	B60378	1	Pump/Manifold Kit (Incl. Items 1A, 9A, 17–19, 56805 [4], B60427, B61016 [2], B61214 [2], B61222 [2] & B62039)
1A	B60386	1	Power Unit-Pump Motor Tank Assy (Incl. Items 1–8, B61631, B61558, B60450, B61632 & B60306)
1	B60346	1	Breather
2	B60388	1	Reservoir
3	B60283	1	Motor, 12V DC
4	B60305	1	Pump Assembly
5	B60308	1	Coupling
6	B60437	1	Filter
7	B60442	1	Elbow
8	B60345	1	Grommet
ns	B61631	2	1/4-20 x 3/4 Hex Cap Screw
ns	91201	2	1/4 Split Lock Washer
ns	B60450	1	Tube, Cut-to-Length Replacement for B60386, B60402 & B60417 Power Units
ns	B61632	4	10-24 Hex Cap Screw w/Nylon Patch
ns	B60343	1	Kit, Brush for 60283 Motor
ns	B60306	1	Kit, Seal
9A	B60344	1	Manifold Assembly
9	B60414	1	Manifold Block
10	B60288	1	Pressure Nipple 1/8 PD -4 FJIC
11	56590	1	9/16-18 90° Hydraulic Adapter Adjustable Elbow ORB
12	B60003	3	7/16-20 x 9/16-18 Hydraulic Adapter Straight ORB
13	B62114	3	Coil, PDL 10V DC
14	B60052	5	1/2-20 Hex Jam Nut
15	B60167	2	Valve, Spool, 4-Way, 2-Position CC
16	B62148	1	Coil Harness Assy (Incl. Items 13, 21 & 24)
ns	B62045	1	Connector, Electric, Male, Plastic
ns	B62096	15	Seal, Cable, Silicone, Orange (18 AWG)
ns	B62097	5	Terminal, Male (18-16 AWG)
ns	B62116	5	Silicone Cavity Plug, White (18-16 AWG)
ns	B62117	1	3/8 End Ring Terminal Copper, 8 ga
17	B61010	2	5/16-18 x 3-3/4 Hex Cap Screw G8
18	B61011	2	5/16 Split Lock Washer
19	B61412	2	5/16 Flat Washer
20	B60510	1	Valve, Spool, 3-Way, 2-Position
21	B62115	1	Coil, DDL 10V DC
22	B60170	1	Valve, Spool, 3-Way, 2-Position
23	B60475	1	Valve, 2-Way
24	B62176	1	Coil, PDL 12V DC, (Waterproof, w/O-rings)
25	B61440	1	10-32 Acorn Hex Nut
26	B60287	1	9/16-18 x 7/16-20 90° Hydraulic Adapter Adjustable
27	B60169	1	Valve, Flow Control
28	B60049	8	Plug, -4 SAE Hollow Hex
29	B60038	2	3/32 CSW 9/16 ID, 3/4 OD O-Ring Neoprene, 70 Durometer
30	B60050	1	Plug, -6 SAE Hollow Hex
31	48412	1	Relief Valve – 3000 psi
			ga = gauge
			G = Grade
			ns = not shown

LIGHTS & CONTROL PARTS – ALL MODELS

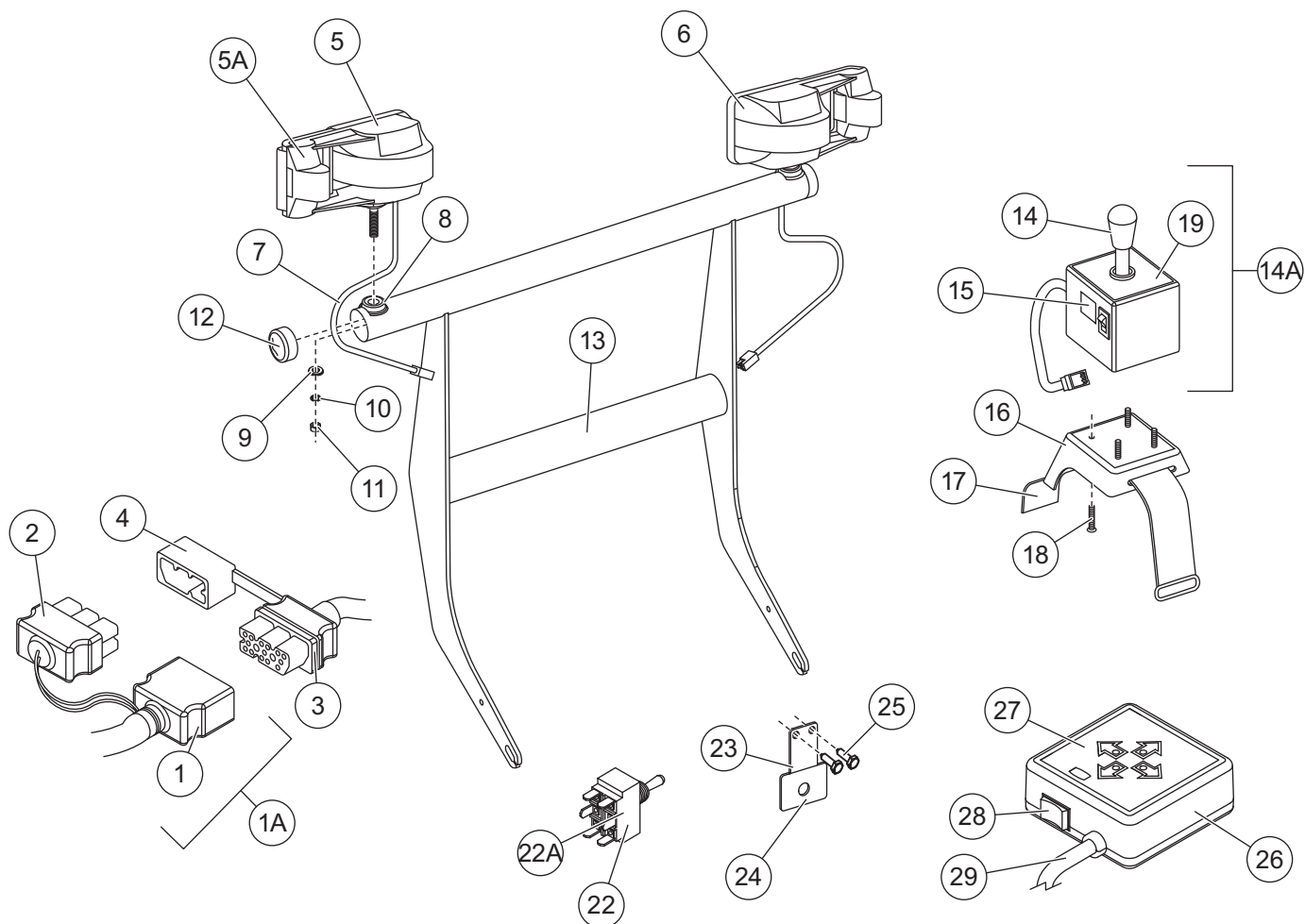

Item	Part	Qty	Description
1A	B62039	1	Harness Assembly, Plow (Incl. Items 1–2, B62046, B62093, B61439 & B62167)
1	B62057	1	Harness, Snowplow
2	B62001	1	Weather Cap, Rubber, Snowplow Side
ns	B62046	1	Connector, Electric, Female, Plastic
ns	B62093	10	Terminal, Female (18-16 AWG)
ns	B61439	2	Cable Tie, Black, 15"
ns	B62167	1	Harness, Diode Loop
3	B62150	1	Harness, Vehicle
4	B62000	1	Weather Cap, Rubber, Vehicle Side
ns	B62124	1	1/4 x 1-1/4 Fuse BUSS ARC 15A, 32V
ns	B62212	1	Harness, Main Lighting
ns	B62035	2	Weather Cap, Rubber, Lighting Harness
ns	B62144	4	Headlamp Relay, CB1-D-12V
	ga = gauge		G = Grade ns = not shown

LIGHTS & CONTROL PARTS – ALL MODELS

Item	Part	Qty	Description
ns	B80051	1	Power Contactor (Solenoid), 12V Continuous
ns	B62056	1	24" Ground Wire, Power Contactor
ns	B62072	4	3/8 End Ring Terminal Copper, 4 ga
ns	B62008	1	Fuse Clip, Mini
ns	B62009	1	Fuse Clip, Auto Blade
ns	B62016	4	Connector, Splice Lock (18-14 AWG)
ns	B61031	3	#12-14 x 3/4 Hex Washer Self-Drilling Screw
5A	B61106	2	Snowplow Headlamp Assy (Incl. Items 5–11 & B62061)
5	B62059	1	Headlamp – DS
6	B62060	1	Headlamp – PS
7	B62032	2	Harness (with 6-pin plug), Snowplow Headlamp Side
ns	B62108	2	Lighting Harness Repair Kit, Harness Side
ns	B62061	2	Bulb, Sealed Beam Halogen (H6545/H4666)
ns	56099	1	Corrosion Preventive Compound (2 fl oz)
8	B61231	1	Adapter, Headlamp Ball Stud Mount
9	B61550	2	1/2 ID x 1 OD Washer Neoprene Backing Galvanized
10	90651	2	7/16 Ext. Tooth Lock Washer
11	B61111	2	7/16-14 Hex Nut G8
12	B61427	2	2-1/4 ID, 2-3/8 OD x 3/4, Black Vinyl Cap
13	B39054	1	Light Tower
14A	B62073	1	Control Station Assy, Joystick (Incl. Items 14–19, B62185–B62190)
14	B62074	1	Control Station, Joystick
15	B63106	1	Label – Snowplow Power Switch, ON/OFF (BLZ 1061)
16	B61185	1	Base Plate, Joystick Control Station 1/8 ABS Plastic
17	B61127	1	61" Hook-and-Loop Fastener Strap with 2" D-Ring, Black
18	B61254	4	8-32 x 3/4 Pan Head Machine Screw
19	B61174	1	Label – Control Station, Joystick (BLZ 1017)
ns	B62185	1	Switch-Rocker SPDT ON-OFF-ON Straight Blade Joystick Control Switch
ns	B62186	1	Switch-Straight Blade Joystick Functions
ns	B62187	1	Relay-Straight Blade Joystick
ns	B62188	1	Switch Actuator
ns	B62189	1	Kit-Handle Straight Blade Joystick (Includes Shaft, Sleeve, E-Ring)
ns	B62190	1	Mounting Plate
22A	B62138	1	Snowplow/Vehicle Headlamp Toggle Switch Connection Kit (Incl. Items 22–25)
22	B62024	1	ON-OFF-ON Toggle Switch, DPDT, 20A/125V AC
23	B61041	1	Bracket, Snowplow/Vehicle Headlamp Toggle Switch
24	B61088	1	Label – Snowplow/Vehicle Headlamp Toggle Switch Bracket (BLZ 1008)
25	B61031	5	#12-14 x 3/4 Hex Washer Self-Drilling Screw
ns	B62127	1	24" ON/OFF Plow Light Switch Lead (Green/Yellow) w/Two 1/4" Receptacles
26	B62142	1	Touchpad Control Station (Incl. Items 37–39)
27	B62192	1	Kit, Decal Touchpad w/Adhesive Pads
28	B62191	1	PC Board, Touchpad Control
29	B62202	1	Harness, Touchpad Control
			ga = gauge G = Grade ns = not shown

ACCESSORIES & KITS – ALL MODELS

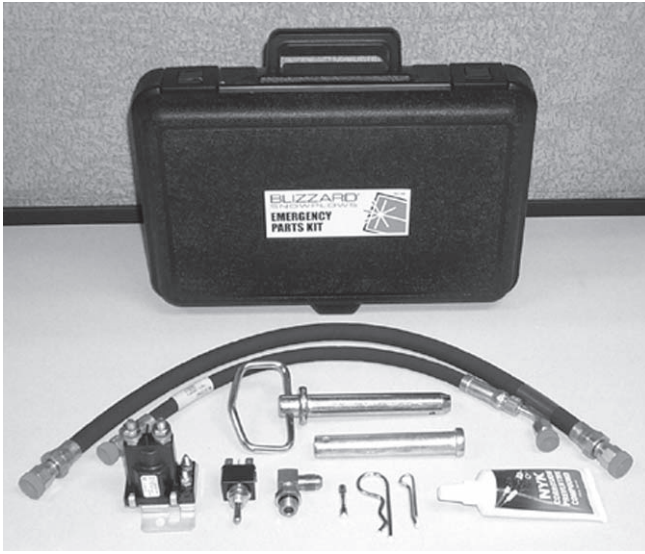

1. This kit includes the most common replacement parts: angle cylinder hose, lift cylinder hose, hitch pin w/hair pin cotter, angle cylinder clevis pin w/cotter, 90° angle cylinder fitting, solenoid, POWER HITCH™ toggle switch, corrosion preventive compound (2 oz) and 10A fuse. The compact and durable plastic case (13.5" x 9" x 3.3") allows for easy storage behind or under your seat.



3. BLIZZARD® hydraulic fluid is specially formulated for use in BLIZZARD snowplows and can significantly enhance the operation and performance of the hydraulic system. BLIZZARD zinc-free hydraulic fluid maintains its viscosity to temperatures as low as -25°F. BLIZZARD fluid is available by the quart, case or 55-gallon drum.

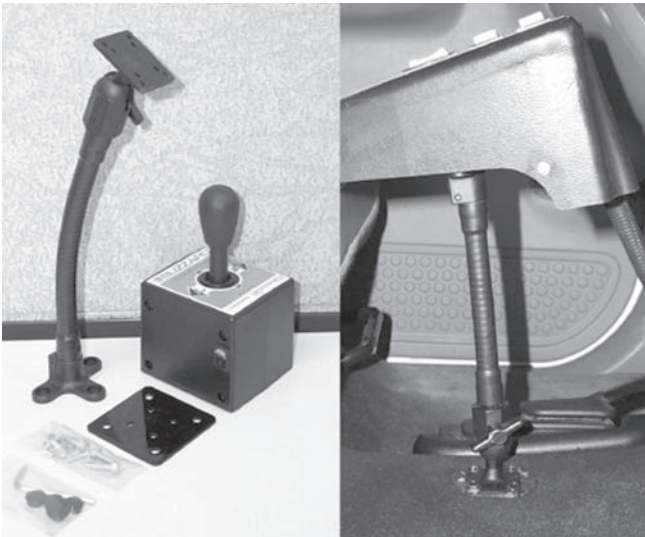

2. Our easy-to-install, adjustable pedestal mount will position either straight blade control station how you want it! Ideal for bucket seat vehicles with low center consoles. Pedestal accessory shipped with complete hardware and adapter plate.



4. Putting your snowplow away for the winter? Have a deep scratch to cover? Clean up your blade and snowplow parts with our gloss spray paints. BLIZZARD touch-up paint provides an excellent finish to help keep your snowplow looking its best. Paint provided in 12 oz spray cans.

ACCESSORIES & KITS – ALL MODELS



5. This adjustable bracket mounts easily to your straight blade joystick control and installs quickly onto any door panel. Ideal for left-hand joystick operation or for vehicles with center consoles. The window mount bracket is shipped complete with hardware. Some assembly required.

6. Ballast (additional weight) is an important part of qualifying vehicles for snowplow eligibility. Rear ballast must be used when necessary to remain in compliance with axle ratings and ratios as specified by the vehicle manufacturer. If ballast is required, it is important that it be secured properly behind the rear axle. A ballast retainer kit is available from your BLIZZARD® outlet, PN 62849.

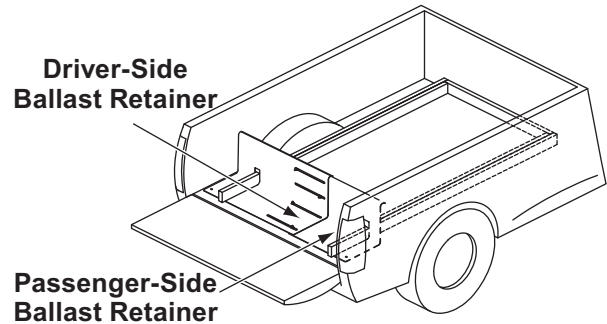

NOTE: The ballast retainer kit is for snowplow vehicles requiring ballast. See your BLIZZARD outlet for the correct amount of ballast required. Include the weight of the retainer as part of the ballast requirement. Sand bags are recommended for use as ballast.

Item	Part	Qty		Description
		680LT	720LT	
1	B63115	1	1	Emergency Parts Kit
2	B63078	1	1	12" Adjustable Pedestal Mount
3	B63070	1	1	BLIZZARD Rapid Action Hydraulic Fluid (Quart)
	B63072	1	1	BLIZZARD Rapid Action Hydraulic Fluid (Gallon)
	B63091	1	1	BLIZZARD Rapid Action Hydraulic Fluid (Drum – 55 gallons)
4	B61219	1	1	BLIZZARD High Performance 12 oz Spray Paint, Gloss White
	B63073	1	1	BLIZZARD High Performance 12 oz Spray Paint, Gloss Black
5	B61261	1	1	Straight Blade Joystick Window Mount Bracket
6	62849	1	1	Ballast Retainer Kit
Kits				
ns	B61454	1	1	Kit, Hardware, Snowplow Assy Parts
ns	B60427	1	1	Kit, Hydraulic Adapter (Incl. Items B60003 [3], B60004 [3], B60008 & B60287)
ns	B60428	1	1	Kit, Hydraulic Hose (Incl. Items B60432, B60293 & B60426 [2])
ns	B61457	1	1	Kit, Hardware, Moldboard Cutting Edge
ns	B61458	1	–	Kit, Cutting Edge, Moldboard w/Hardware
ns	B61531	–	1	Kit, Cutting Edge, Moldboard w/Hardware
ns	B60372	2	2	Combo Seal Kit, Cyl B60277
ns	B60370	1	1	Combo Seal Kit, Cyl B60254
ns	B62195	1	1	Kit, Headlamp B61106 (1-Sealed Beam, 1-Rim , 4-Spacer Bumpers, 4-Screws)
ns	B62196	1	1	Kit, Headlamp B61106 Signal (1-Bulb, 1-Turn Signal Lens, 1- Gasket, 2-Screws)
ns	96020	1	–	Moldboard Label Pack
ns	96021	–	1	Moldboard Label Pack
ns = not shown				



Blizzard
PO Box 245038
Milwaukee, WI 53224-9538
www.blizzardplows.com



 A DIVISION OF DOUGLAS DYNAMICS, L.L.C.

Copyright © 2010 Douglas Dynamics, L.L.C. All rights reserved. This material may not be reproduced or copied, in whole or in part, in any printed, mechanical, electronic, film or other distribution and storage media, without the written consent of Blizzard. Authorization to photocopy items for internal or personal use by Blizzard outlets or snowplow owner is granted.

Blizzard reserves the right under its product improvement policy to change construction or design details and furnish equipment when so altered without reference to illustrations or specifications used. Blizzard or the vehicle manufacturer may require or recommend optional equipment for snow removal. Do not exceed vehicle ratings with a snowplow. This product is manufactured under the following U.S. patents: 5,420,480; 5,638,618; 5,899,007; 6,178,669; 6,253,470; 6,276,076; 6,393,737; 6,408,549; 6,412,199; 6,442,877; 6,615,513; 7,134,227; 7,430,821; RE35,700; CAN patents 2,060,425; 2,184,922; 2,229,783; 2,259,508; 2,358,145; 2,358,354; 2,466,195; and other patents pending. Blizzard offers a limited warranty for all snowplows and accessories. See separately printed page for this important information. The following are registered (®) or unregistered (™) trademarks of Douglas Dynamics, L.L.C.: BLIZZARD®, POWER HITCH™.

Printed in U.S.A.