

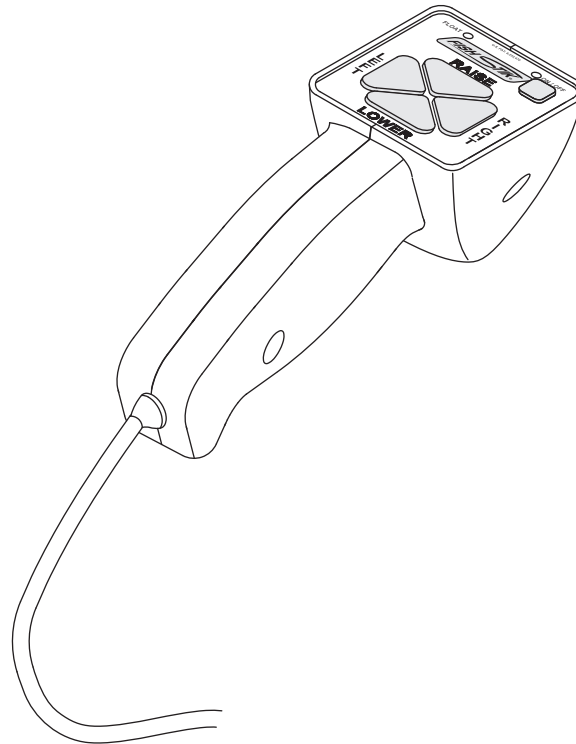

CONTROL KIT

Fish-Stik® Hand-Held Installation Instructions



⚠ CAUTION

Read this document before installing the Fish-Stik Hand-Held Control.

⚠ CAUTION

Use standard methods and practices when attaching snowplow and installing accessories including proper personal protective safety equipment.

SAFETY DEFINITIONS

⚠ WARNING

Indicates a potentially hazardous situation that, if not avoided, could result in death or serious personal injury.

⚠ CAUTION

Indicates a potentially hazardous situation that, if not avoided, may result in minor or moderate injury. It may also be used to alert against unsafe practices.

NOTE: Indicates a situation or action that can lead to damage to your snowplow and vehicle or other property. Other useful information can also be described.

FUSES

The FISHER® electrical and hydraulic systems contain several blade-style automotive fuses. If a problem should occur and fuse replacement is necessary, the replacement fuse must be of the same type and amperage rating as the original. Installing a fuse with a higher rating can damage the system and could start a fire. Fuse Replacement, including fuse ratings and locations, is located in the Maintenance Section of the Owner's Manual.

The white label on the control's coiled cord applies only to systems without the Isolation Module Electrical System.

CONTROL PLACEMENT

⚠ CAUTION

Before drilling holes, check to be sure that no vehicle wiring or other components could be damaged.

⚠ CAUTION

Do not alter, modify, or install additional components in shaded areas of the following illustration. Failure to comply may interfere with air bag deployment or cause injury to operator in an accident.

When choosing a location for your control, it should be mounted in easy reach of the vehicle operator and not restricting access to vehicle controls or vehicle instrumentation. Do not mount the control in areas prohibited by the vehicle manufacturer for crash worthiness. See the vehicle's body builder's book, owner's manual, or service manual for details. The shaded areas in the illustration below show the most commonly restricted areas.

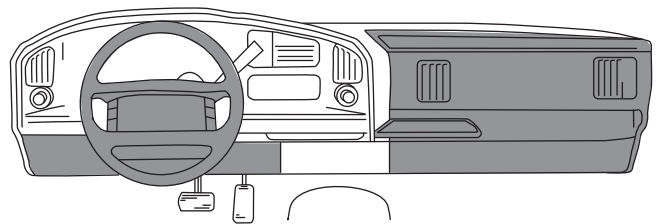

INSTALLATION INSTRUCTIONS

Park the vehicle on a smooth, level, hard surface, such as concrete. Lower the blade to the ground, and turn the control to the "OFF" position. Disconnect the snowplow from the vehicle, or turn the vehicle ignition to the "OFF" position and remove the key.

These instructions cover both new installations and replacement of existing controls. To determine if modifications to electrical system are required:

- Locate the white plastic cab control connector under the dash.
- Follow the black braided harness to the place where the red wire breaks out of the harness.
- Follow the red wire:
- If the red wire leads to an inline fuse holder, follow instructions for earlier system modifications.
- If no inline fuse holder is found, follow new system instructions.

New Systems

1. Follow the instructions furnished with the snowplow to install the vehicle harness.
2. Locate the white connector on the end of the vehicle harness that has been routed into the vehicle cab.
3. Mate the end of the coil cord on the control with the end of the vehicle harness.
4. Secure the vehicle harness so that it is easy to mate and unmate the control cord connector.
5. The control may be removed when the snowplow is removed from the vehicle and stored in the glove box

Earlier Installations Originally Equipped with Joystick Controls

Two items must be verified before installing the Fish-Stik® control:

- The vehicle harness has the correct size fuse.
- The ground circuit of the vehicle harness is correct for the Fish-Stik control.

Verify Fuse Type

⚠ CAUTION

If the fuse being used is greater than 6 amp rated, damage to the cab control could result.

1. Turn vehicle key to the "OFF" position.
2. Disassemble the fuse holder and examine the fuse rating on the fuse. If the fuse is an *SFE-6*, no modifications are necessary. Reassemble the fuse holder assembly and plug in the control. Otherwise, proceed with the following instructions.

For fuse holder with white body and black cap:

1. Disconnect the red fuse holder wire from the power source. The fuse holder is part of the vehicle control harness and is located near the fuse box under the dash board.
2. Remove the red wire and spring from the white fuse holder body.
3. Insert the red wire and the short spring (PN 56469*) into the fuse holder body.
4. Reassemble the fuse holder and cap using a SFE-6 fuse (PN 80168*).
5. Reconnect the red fuse holder wire to the power source.
6. Install a label (PN 56423*) onto the red wire nearest to the fuse holder.

* Parts sold separately.

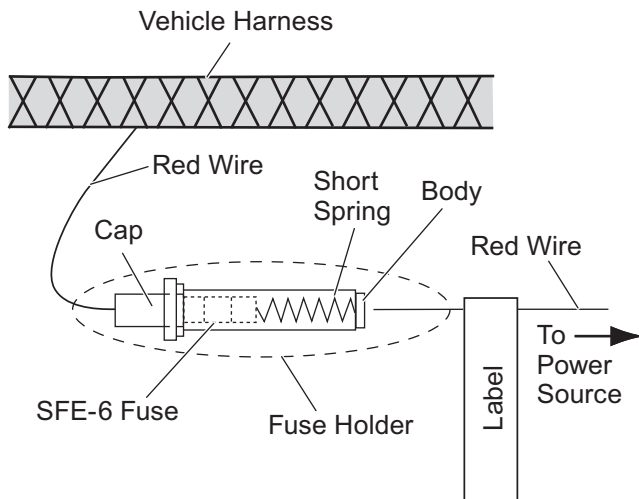

For fuse holder with black body and cap:

1. Disconnect the red fuse holder wire from the power source. The fuse holder is part of the vehicle control harness and is located near the fuse box under the dash board.
2. Cut red wire connecting fuse holder body to braided vehicle harness in a convenient location for reattachment later.
3. Remove the red wire and spring from the black fuse holder body.
4. Reassemble the red wire and the long spring (PN 56468*) into the fuse holder body.
5. Reassemble the fuse holder body and cap with an SFE-6 fuse (PN 80168*).
6. Strip the wire ends cut in Step 2.
7. Use a band splice with protective heat shrink tubing, an insulated butt splice, or solder and tape to reconnect wire ends.
8. Reconnect the red fuse holder wire to the power source.
9. Install a label (PN 56423*) onto the red wire nearest to the fuse holder.

* Parts sold separately.

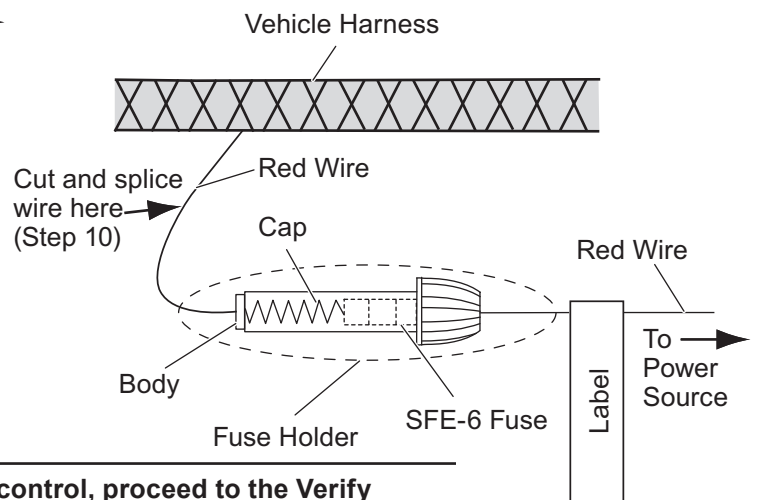

NOTE: Before plugging in the control, proceed to the Verify Vehicle Harness Ground Circuit instructions on next page.

NOTE: An adaptor (PN 21019K) is available for the harness containing the black SAE plug.

Verify Vehicle Harness Ground Circuit

⚠ CAUTION

Read the following instructions. Failure to do so may cause damage to the control or inadvertent operation of the snowplow.

There were two types of relay system wiring harnesses in earlier production.

If you have the arrangement shown below you **DO NOT** need to make any further modifications and may plug in the control as instructed in the "New Systems" section of these instructions.

Most Recent Harness (No Modification Required)

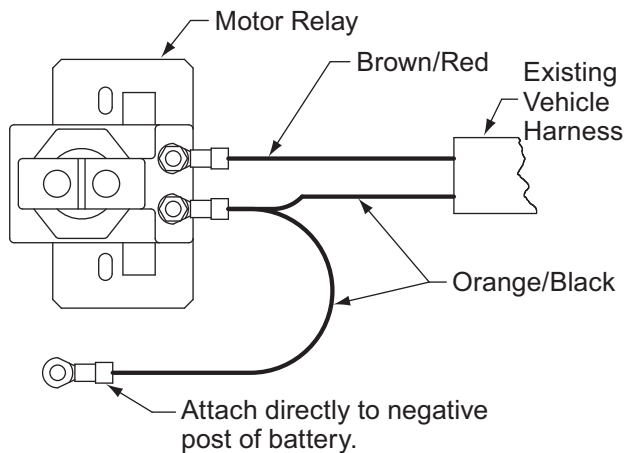

If you have either of the following arrangements, you **MUST** proceed to the section(s) indicated.

Early SEHP Harness (Modification Required)

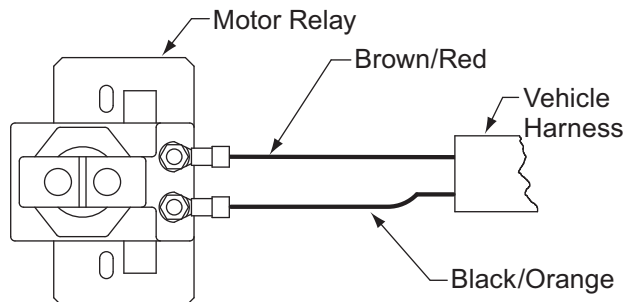

Proceed to the Under-Hood and Control Ground Modification sections before installing the control.

Early Electric Clutch Harness (Modification Required)

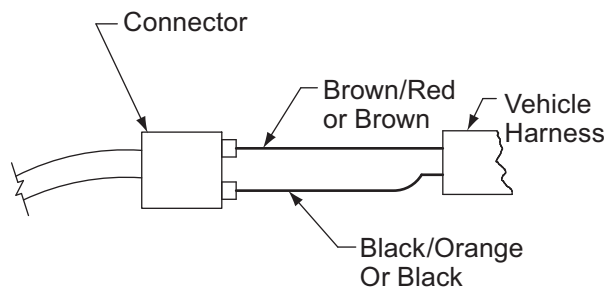

Proceed to the Control Ground Modification section only for electric clutch applications.

The Fish-Stik®/Clutch Relay Kit (PN 20850) must be installed if not already present according to the instructions in the kit.

Under-Hood Modification Instructions (SEHP Hydraulic Systems Only)

⚠ CAUTION

The under-hood modification shown is for the SEHP Hydraulic System *only*. Performing this modification with the Electric Clutch System could cause personal injury and/or property damage.

1. Cut off the Black/Orange wire near the braid as shown in opposite column.
2. Tape the stub to prevent it from shorting.
3. Install a 16 gauge wire with two ring terminals from the motor relay directly to the NEGATIVE (-) battery post.

NOTE: Before plugging in the control, proceed to the Control Ground Modification Instructions. Failure to do so will result in grounded headlamp relays, which will cause the vehicle headlamps to remain OFF when the snowplow is removed.

Under-Hood Modification (SEHP Only)

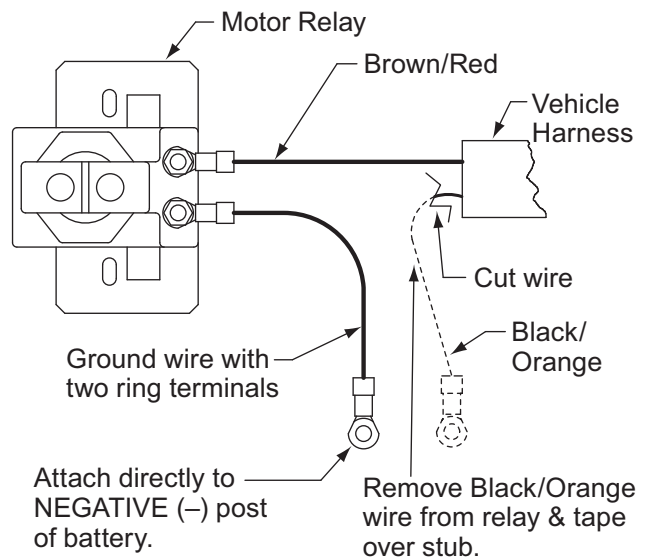

Control Ground Modification Instructions (SEHP and Electric Clutch Hydraulic Systems)

⚠ CAUTION

Operation of this control without ground modifications could result in damage to the control.

1. Turn vehicle key to the "OFF" position.
2. In the cab, locate the harness coming through the firewall. Measure back at least 12 inches from the firewall and carefully cut the braiding of the vehicle harness. Make the cut approximately 3 inches in length. **Do not cut into the insulation of the wires within the harness braiding.** (See diagram below.)
3. Locate the Black/Orange striped wire.
4. To allow for sufficient wire length, cut the Black/Orange striped wire as far away as possible from the control end (white plastic connector).
5. Protect the short end of Black/Orange striped wire by taping braid around it.
6. Strip 1/4" of the insulation from the end of Black/Orange striped wire coming from the white plastic connector.
7. Use a band splice with protective heat shrink tubing, an insulated butt splice, or solder and tape to attach a 16 gauge wire long enough to go through the firewall and route it to the battery. Avoid sharp edges, and hot or moving engine parts. Secure wire as required to prevent damage.
8. Attach a ring terminal to the end of the wire. Attach the ring terminal to the NEGATIVE (-) battery connection.
9. Once all modifications have been completed, plug in the control:
 - Locate the white connector on the end of the vehicle harness that has been routed into the vehicle cab.
 - Mate the end of the coil cord on the control with the end of the vehicle harness.
 - Secure the vehicle harness so that it is easy to mate and unmate the control cord connector.
 - The control may be removed when the snowplow is removed from the vehicle and stored in the glove box.

Ground Wire Modification

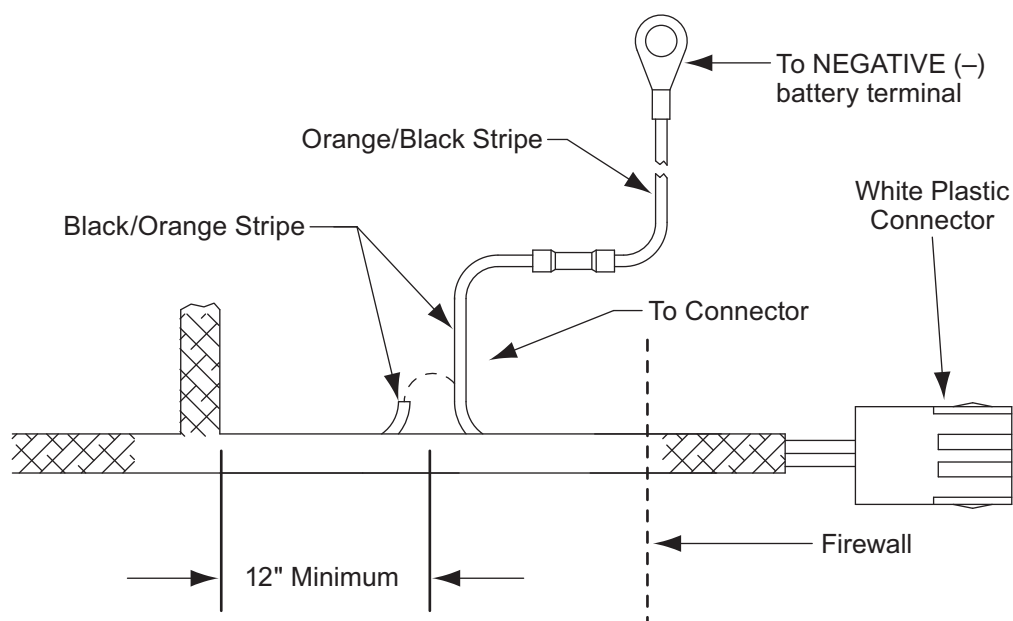

Fisher Engineering reserves the right under its product improvement policy to change construction or design details and furnish equipment when so altered without reference to illustrations or specifications used. Fisher Engineering or the vehicle manufacturer may require or recommend optional equipment for snow removal. Do not exceed vehicle ratings with a snowplow. Fisher Engineering offers a limited warranty for all snowplows and accessories. See separately printed page for this important information. The following are registered (®) trademarks of Douglas Dynamics, L.L.C.: FISHER®, Fish-Stik®.

Printed in U.S.A.
