

31543-1

MOUNT KIT PERSONAL PLOW

GM Colorado/Canyon

2004 - ____

Installation Instructions

⚠ CAUTION

Read this document before installing the snowplow.

⚠ CAUTION

See your sales outlet/Web site for specific vehicle application recommendations before installation. The Kit Selection Guide/Selection List has specific vehicle and snowplow requirements.

SAFETY DEFINITIONS

⚠ WARNING

Indicates a potentially hazardous situation that, if not avoided, could result in death or serious personal injury.

⚠ CAUTION

Indicates a potentially hazardous situation that, if not avoided, may result in minor or moderate injury. It may also be used to alert against unsafe practices.

NOTE: Indicates a situation or action that can lead to damage to your snowplow and vehicle or other property. Other useful information can also be described.

WARNING/CAUTION & INSTRUCTION LABELS

Become familiar with and inform users about the warning/caution labels on the back of the blade and the instruction label on the headgear.

NOTE: If labels are missing or cannot be read, see your sales outlet.

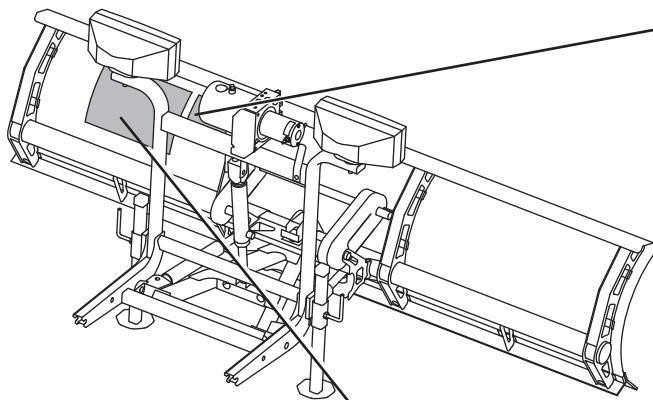

⚠ WARNING

LOWER BLADE WHEN VEHICLE IS PARKED.

DO NOT EXCEED GVWR OR GAWR INCLUDING BLADE AND BALLAST.

REMOVE BLADE ASSEMBLY BEFORE PLACING VEHICLE ON HOIST.

⚠ CAUTION

READ *OWNER'S MANUAL* BEFORE OPERATING OR SERVICING SNOWPLOW.

TRANSPORT SPEED SHOULD NOT EXCEED 45 MPH. FURTHER REDUCE SPEED UNDER ADVERSE TRAVEL CONDITIONS.

PLOWING SPEED SHOULD NOT EXCEED 10 MPH.

SEE YOUR SALES OUTLET/WEB SITE FOR SPECIFIC VEHICLE APPLICATION RECOMMENDATIONS.

This snowplow is for personal/homeowner use only.

ATTACH INSTRUCTIONS

1. Make certain both **connecting pins** are fully retracted.
2. Drive vehicle slowly to completely insert **attachment arms** into **receiver assembly** slots.
3. Twist both **connecting pins** to release spring tension, then push **plow gear** toward vehicle so **connecting pins** fully engage holes in **attachment arms**.
4. Loosen one **jack handle** and slide **jack sleeve** down below **jack retainer**. Remove **jack** and retighten **jack handle**. Repeat for other **jack** and store them.
5. Connect all electrical cables from vehicle to snowplow.

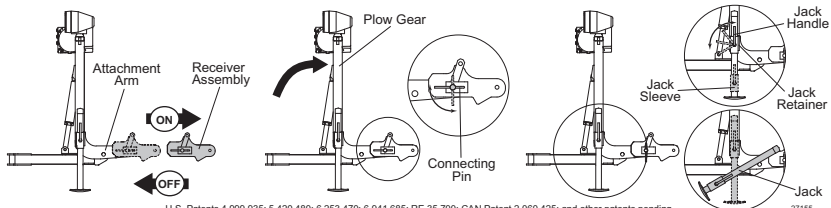

U.S. Patents 4,999,935; 5,420,480; 6,253,470; 6,941,685; RE 35,700; CAN Patent 2,060,425; and other patents pending. 27155

DETACH INSTRUCTIONS

5. Back vehicle away from snowplow.
6. See Owner's Manual for proper snowplow storage.
3. While pushing **plow gear** toward vehicle to release **connecting pin** tension, pull **connecting pin** out on one side and twist pin handle to keep pin retracted. Repeat procedure for other **connecting pin**.
4. Disconnect all electrical cables.
1. Put blade on ground using **LOWER/FLOAT** on snowplow control. Leave control **ON** and in **FLOAT**.
2. Attach **jacks**. Loosen **jack handle**, put **jack** on ground, and raise **jack sleeve** until fully engaging **jack retainer**. Tighten **jack handle**. Repeat for other **jack**.

Read Owner's Manual for Complete Instructions

SAFETY PRECAUTIONS

Improper installation and operation could cause personal injury and/or equipment and property damage. Read and understand labels and the Owner's Manual before installing, operating or making adjustments.

⚠ WARNING

Lower blade when vehicle is parked. Temperature changes could change hydraulic pressure, causing the blade to drop unexpectedly or damaging hydraulic components. Failure to do this could result in serious personal injury.

⚠ WARNING

The driver shall keep bystanders clear of the blade when it is being raised, lowered or angled. Do not stand between the vehicle and the blade or within 8 feet of a moving blade. A moving or falling blade could cause personal injury.

⚠ WARNING

Keep hands and feet clear of the blade and A-frame when mounting or removing the snowplow. Moving or falling assemblies could cause personal injury.

⚠ WARNING

Do not exceed GVWR or GAWR including the blade and ballast. The rating label is found on the driver-side vehicle door cornerpost.

⚠ WARNING

To prevent accidental movement of the blade, always turn the ON/OFF switch to OFF whenever the snowplow is not in use. The control indicator light will turn off.

⚠ WARNING

Remove blade assembly before placing vehicle on hoist.

⚠ CAUTION

Refer to the Kit Selection Guide/Selection List for minimum vehicle recommendations and ballast requirements.

PERSONAL SAFETY

- Remove ignition key and put the vehicle in park or in gear to prevent others from starting the vehicle during installation or service.
- Wear only snug-fitting clothing while working on your vehicle or snowplow.
- Do not wear jewelry or a necktie, and secure long hair.
- Wear safety goggles to protect your eyes from battery acid, gasoline, dirt and dust.
- Avoid touching hot surfaces such as the engine, radiator, hoses and exhaust pipes.
- Always have a fire extinguisher rated BC handy, for flammable liquids and electrical fires.

FIRE AND EXPLOSION

⚠ WARNING

Gasoline is highly flammable and gasoline vapor is explosive. Never smoke while working on vehicle. Keep all open flames away from gasoline tank and lines. Wipe up any spilled gasoline immediately.

Be careful when using gasoline. Do not use gasoline to clean parts. Store only in approved containers away from sources of heat or flame.

CELL PHONES

A driver's first responsibility is the safe operation of the vehicle. The most important thing you can do to prevent a crash is to avoid distractions and pay attention to the road. Wait until it is safe to operate Mobile Communication Equipment such as cell phones or two-way radios.

VENTILATION



⚠ WARNING

Vehicle exhaust contains lethal fumes. Breathing these fumes, even in low concentrations, can cause death. Never operate a vehicle in an enclosed area without venting exhaust to the outside.

TORQUE CHART

⚠ CAUTION

Read instructions before assembling. Fasteners should be finger tight until instructed to tighten according to the torque chart. Use standard methods and practices when attaching snowplow including proper personal protective safety equipment.

Recommended Fastener Torque Chart (ft-lb)			
Size	 SAE Grade 2	 SAE Grade 5	 SAE Grade 8
1/4-20	6	9	13
5/16-18	11	18	28
3/8-16	19	31	46
3/8-24	24	46	68
7/16-14	30	50	75
1/2-13	45	75	115
9/16-12	66	110	165
5/8-11	93	150	225
3/4-10	150	250	370
7/8-9	150	378	591
1-8	220	583	893

Metric Grade 8.8 (ft-lb)			
Size	Torque	Size	Torque
M 6	7	M 12	60
M 8	17	M 14	95
M 10	35	M 16	155

These torque values apply to fasteners except those noted in the instruction.

INSTALLATION INSTRUCTIONS

NOTE: For easier assembly and installation, vehicle and all snowplow components should be on a smooth, level, hard surface, such as concrete.

1. Remove the plastic grille by detaching the four upper plastic clips by pushing down on the center tab. Then pull gently on the grille until the lower push clips release.
2. Remove the front bumper by removing the two cap screws from each side bracket and the four cap screws (two on each side) from beneath the grille. Retain the fasteners for reinstallation of the bumper.
3. Remove the spoiler from the bottom of the air dam. The spoiler cannot be used with the mount installed.
4. Cut the air dam as shown below.

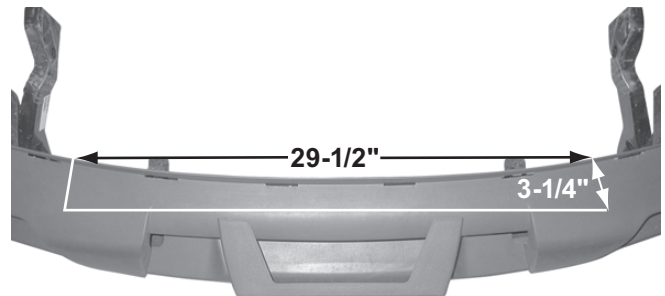

5. If the vehicle is equipped with tow hooks, remove both tow hooks. Retain tow hooks and fasteners for reinstallation.
6. Notch both sides of the plastic air baffle below the radiator as shown. On some vehicles it will be necessary to cut completely across the baffle at the 1" dimension.

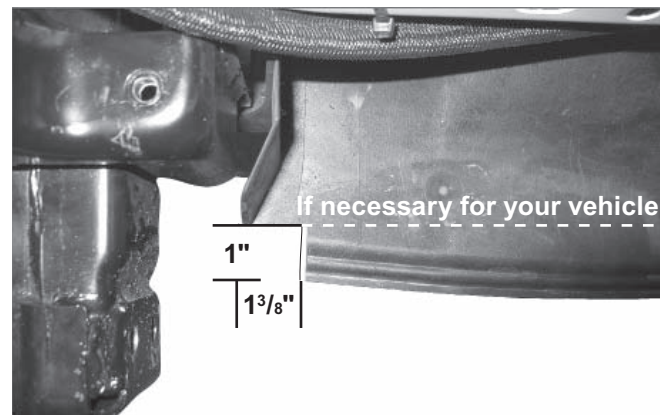

7. Align the holes in the front of the mount with the existing holes at the front of the frame.

If the vehicle was equipped with tow hooks, reinstall the tow hooks and original fasteners by inserting the fasteners through the tow hook and mount, then into the frame. Hand tighten.

If the vehicle was not so equipped, install the mount by placing four of the M12 washers onto the four M12 x 100 cap screws, then inserting through the mount and into the truck frame. Place a second washer and M12 locknut onto each cap screw and hand tighten.

8. Push the rear supports of the mount up against the bottom of the frame and align the rear hole with the existing hole in the bottom of the frame.
9. Using the large access hole in the side of the vehicle frame behind the mount, install the flanged cap screws with handles out through the existing hole in the frame and the rear hole of the mount. Place a 1/2" locknut on the cap screw and hand tighten.

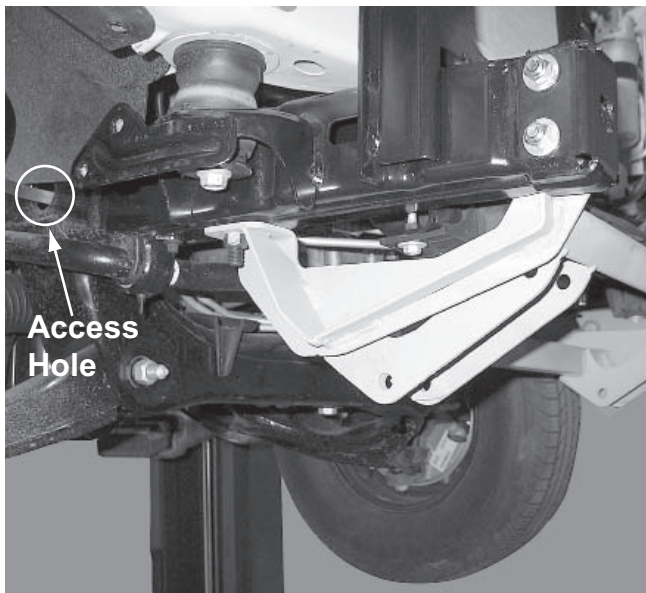

10. Hold the mount tight to the bottom of the frame using a floor jack. Tighten all fasteners according to the torque chart provided in these instructions.

11. On level ground measure the distance between rear receiver hole and the ground. If this measurement exceeds 11-1/2", install the extension brackets per the instructions provided.

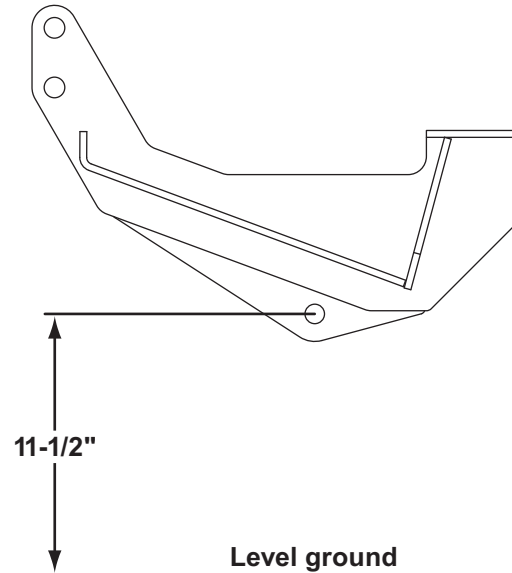

12. Reinstall the bumper and grille.

NOTE: After five to ten hours of snowplow usage, retorque all mount assembly fasteners.

The company reserves the right under its product improvement policy to change construction or design details and furnish equipment when so altered without reference to illustrations or specifications used. This equipment manufacturer or the vehicle manufacturer may require or recommend optional equipment for snow removal. Do not exceed vehicle ratings with a snowplow. The company offers a limited warranty for all snowplows and accessories. See separately printed page for this important information.

Printed in U.S.A.
