

31599 MOUNT KIT

GM K1500 All New Silv/Sierra

2007 - ____

Installation Instructions

▲ CAUTION

Read this document before installing the snowplow.

▲ CAUTION

See your sales outlet/Web site for specific vehicle application recommendations before installation. The Selection List/Undercarriage Selection Guide has specific vehicle and snowplow requirements.

SAFETY DEFINITIONS

⚠ WARNING
 Indicates a potentially hazardous situation that, if not avoided, could result in death or serious personal injury.

⚠ CAUTION
 Indicates a potentially hazardous situation that, if not avoided, may result in minor or moderate injury. It may also be used to alert against unsafe practices.

NOTE: Indicates a situation or action that can lead to damage to your snowplow and vehicle or other property. Other useful information can also be described.

WARNING/CAUTION & INSTRUCTION LABELS

Become familiar with and inform users about the warning and instruction labels on the back of the blade.

NOTE: If labels are missing or can not be read, see your sales outlet.

Warning and Caution Label

⚠ WARNING
LOWER BLADE WHEN VEHICLE IS PARKED. DO NOT EXCEED GVWR OR GAWR INCLUDING BLADE AND BALLAST. REMOVE BLADE ASSEMBLY BEFORE PLACING VEHICLE ON HOIST.
⚠ CAUTION
READ <i>OWNER'S MANUAL</i> BEFORE OPERATING OR SERVICING SNOWPLOW. TRANSPORT SPEED SHOULD NOT EXCEED 45 MPH. FURTHER REDUCE SPEED UNDER ADVERSE TRAVEL CONDITIONS. PLOWING SPEED SHOULD NOT EXCEED 10 MPH. SEE YOUR SALES OUTLET/WEB SITE FOR SPECIFIC VEHICLE APPLICATION RECOMMENDATIONS.

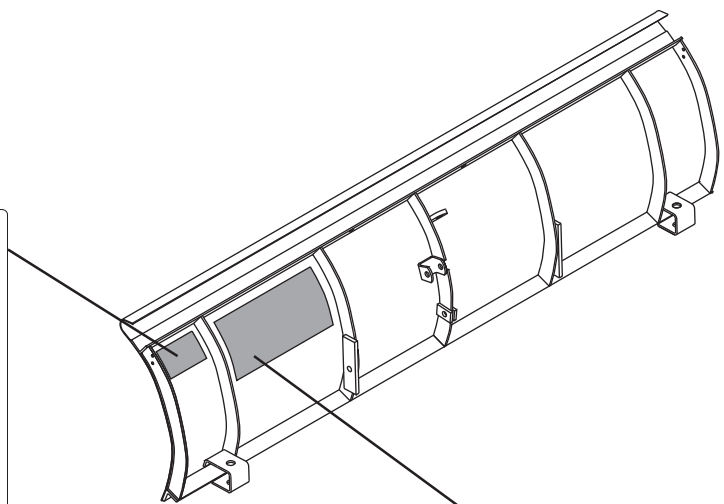

Attach/Detach Instruction Label

SAFETY PRECAUTIONS

Improper installation and operation could cause personal injury and/or equipment and property damage. Read and understand labels and the Owner's Manual before installing, operating, or making adjustments.

⚠ WARNING

Lower blade when vehicle is parked. Temperature changes could change hydraulic pressure, causing the blade to drop unexpectedly or damaging hydraulic components. Failure to do this can result in serious personal injury.

⚠ WARNING

The driver shall keep bystanders clear of the blade when it is being raised, lowered, or angled. Do not stand between the vehicle and the blade or within 8 feet of a moving blade. A moving or falling blade could cause personal injury.

⚠ WARNING

Keep hands and feet clear of the blade and A-frame when mounting or removing the snowplow. Moving or falling assemblies could cause personal injury.

⚠ WARNING

Do not exceed GVWR or GAWR including blade and ballast. The rating label is found on driver-side vehicle door cornerpost.

⚠ WARNING

To prevent accidental movement of the blade, always turn the ON/OFF switch to OFF whenever the snowplow is not in use. The control indicator light will turn off.

⚠ WARNING

Remove blade assembly before placing vehicle on hoist.

⚠ CAUTION

Refer to the Kit Selection Guide/Selection List for minimum vehicle recommendations and ballast requirements.

PERSONAL SAFETY

- Remove ignition key and put the vehicle in park or in gear to prevent others from starting the vehicle during installation or service.
- Wear only snug-fitting clothing while working on your vehicle or snowplow.
- Do not wear jewelry or a necktie, and secure long hair.
- Wear safety goggles to protect your eyes from battery acid, gasoline, dirt, and dust.
- Avoid touching hot surfaces such as the engine, radiator, hoses, and exhaust pipes.
- Always have a fire extinguisher rated BC handy, for flammable liquids and electrical fires.

FIRE AND EXPLOSION

⚠ WARNING
 Gasoline is highly flammable and gasoline vapor is explosive. Never smoke while working on a vehicle. Keep all open flames away from gasoline tanks and lines. Wipe up any spilled gasoline immediately.



Be careful when using gasoline. Do not use gasoline to clean parts. Store only in approved containers away from sources of heat or flame.

VENTILATION

⚠ WARNING
 Vehicle exhaust contains lethal fumes. Breathing these fumes, even in low concentrations, can cause death. Never operate a vehicle in an enclosed area without venting exhaust to the outside.

TORQUE CHART

⚠ CAUTION
 Read instructions before assembling. Fasteners should be finger tight until instructed to tighten according to the torque chart. Use standard methods and practices when attaching snowplow including proper personal protective safety equipment.

Recommended Fastener Torque Chart (ft-lb)			
Size	 SAE Grade 2	 SAE Grade 5	 SAE Grade 8
1/4-20	6	9	13
5/16-18	11	18	28
3/8-16	19	31	46
3/8-24	24	46	68
7/16-14	30	50	75
1/2-13	45	75	115
9/16-12	66	110	165
5/8-11	93	150	225
3/4-10	150	250	370
7/8-9	150	378	591
1-8	220	583	893
Metric Grade 8.8 (ft-lb)			
Size	Torque	Size	Torque
M 6	7	M 12	60
M 8	17	M 14	95
M 10	35	M 16	155
These torque values apply to fasteners except those noted in the instruction.			

INSTALLATION INSTRUCTIONS

NOTE: For easier assembly and installation, vehicle and all snowplow components should be on a smooth, level, hard surface, such as concrete.

1. Remove the air dam from the lower plastic portion of the bumper. Retain air dam and fasteners for future use.
2. Remove the lower plastic portion of the bumper from the vehicle. Retain fasteners.
3. Remove the splash shield. Retain fasteners.
4. On the passenger's side of the vehicle, remove and retain the tow hook fasteners for reinstallation in the following step.

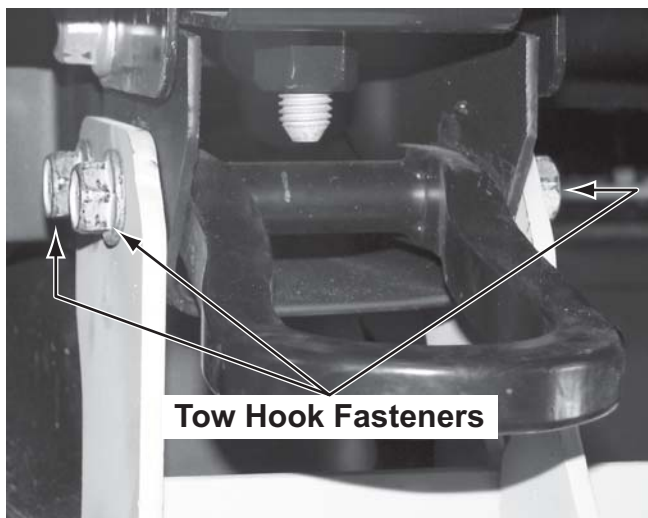

5. Attach the passenger-side mount and tow hook to the truck frame using the original tow hook fasteners. Hand tighten.
6. Push the passenger-side mount tight against the bottom of the frame, and clamp it into place.

⚠ CAUTION

Use caution not to pinch, cut or drill through any wires or hoses running along the frame rail.

7. Using the front hole in the passenger-side mount as a guide, drill a 17/32" hole into the truck frame.

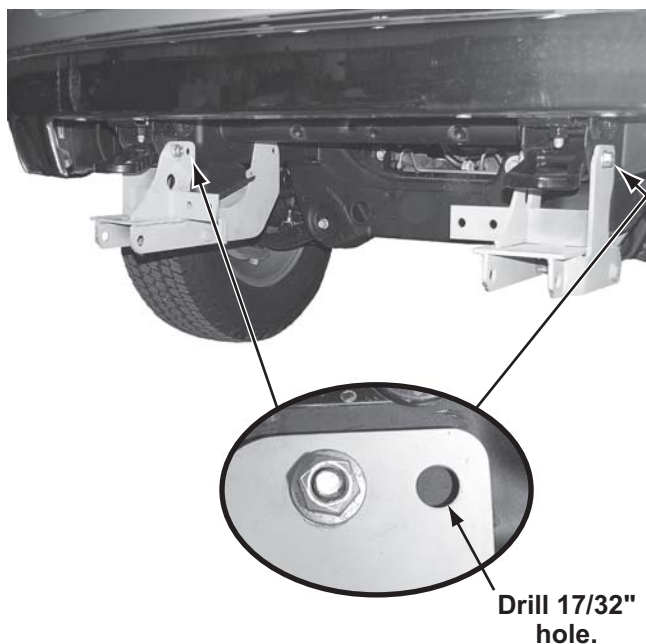

8. Using the rear holes in the passenger-side mount as a guide, drill two 17/32" holes into the truck frame.

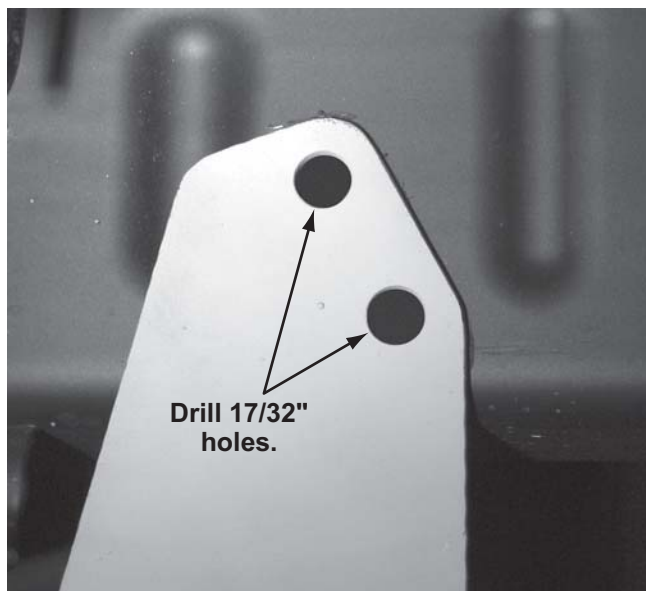

9. Insert two 1/2" x 1-1/4" cap screws with handles and 1/2" flat washers into the inside of the truck frame and out through the rear drilled holes. Attach a 1/2" locknut to each cap screw and hand tighten.
10. Completely remove the passenger-side tow hook. Retain fasteners for reinstallation in Step 12.
11. Insert one 1/2" x 1-1/2" cap screw and 1/2" flat washer into the front of the truck frame and out through the front drilled hole. Attach a 1/2" locknut, and hand tighten.
12. Reinstall the passenger-side tow hook using the original fasteners, and hand tighten. Remove the clamp from the mount.
13. Repeat Steps 4–12 on the driver's side of the vehicle.
14. Install the cross bar using four 1/2" x 1-1/2" cap screws and 1/2" locknuts. Hand tighten fasteners.
15. Make sure that the mounts are tight against the truck frame. Then, fully tighten the fasteners securing the mounts and tow hooks, followed by the fasteners securing the cross bar, according to the torque chart.
16. Check for a U-bracket distance of $30\text{-}7\text{/}16" \pm 1\text{/}8"$. Take a second measurement farther back on the mounts to ensure that they are parallel. If the U-bracket distance is not within $30\text{-}7\text{/}16" \pm 1\text{/}8"$, then 1/2" flat washers may be used to shim one or both mounts in the appropriate direction to obtain the desired dimension. Tighten all fasteners according to the torque chart after achieving the appropriate dimensions.

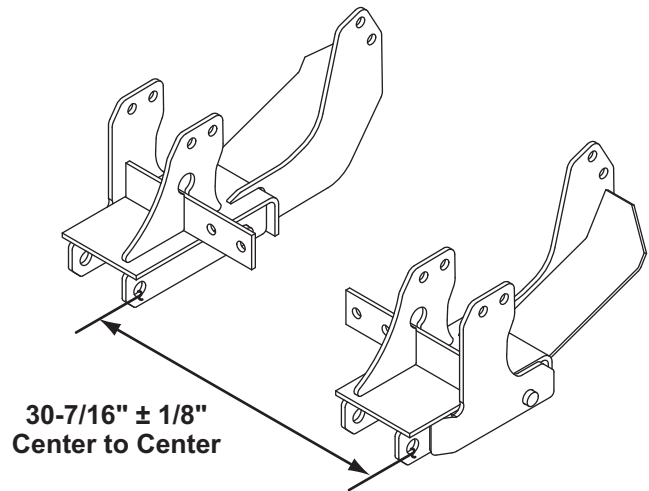

17. Reattach the splash shield using the original fasteners.
18. If the lower plastic portion of the bumper does not clear the U-brackets, remove or notch as needed.

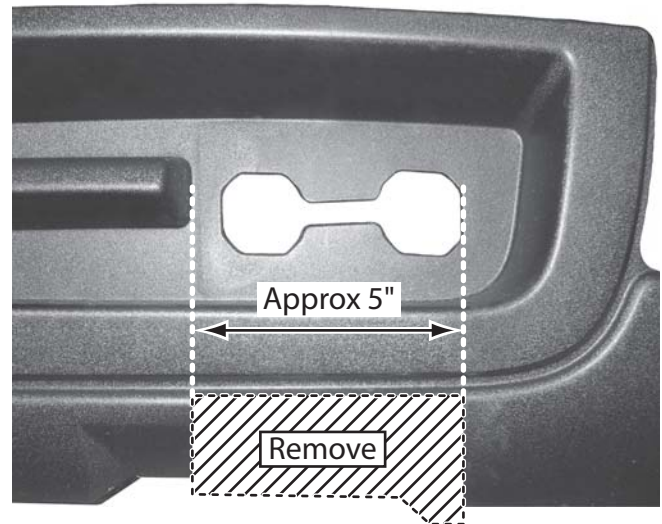

19. Reattach the lower plastic portion of the bumper using the original fasteners.

NOTE: After five to ten hours of snowplow usage, retorque all mount assembly fasteners.

The company reserves the right under its product improvement policy to change construction or design details and furnish equipment when so altered without reference to illustrations or specifications used. This equipment manufacturer or the vehicle manufacturer may require or recommend optional equipment for snow removal. Do not exceed vehicle ratings with a snowplow. The company offers a limited warranty for all snowplows and accessories. See separately printed page for this important information.