



Harness Configuration Instructions

Ford / Mazda with HB-1 or HB-5 Style Headlamps

Contents

	Page
Ford / Mazda with HB-5 Headlamps	2
1992-__ Ford F-Series	
1993-__ Ranger	
1992 Bronco	
1994-__ Mazda B3000 & B4000	
Ford / Mazda with HB-1 Headlamps	3
1987-91 Ford F-Series, Bronco	
1991-94 Explorer	
1991-94 Mazda Navajo	
1992 Ranger	

This kit can be configured for multiple applications.

- The 8269B harness replaces plug-in harness 8269.
- The 8269B harness replaces plug-in harness 8266.

Parts List

Qty	Part #	Description
1	20581	Plug-in Harness
1	20589	Plug-in Adapter

FORD/MAZDA HB-5 HEADLIGHTS

(REPLACES PLUG-IN HARNESS #8269)

P1 / P2 PINOUT

- POSITION A - ORANGE
- POSITION B - BLUE
- POSITION C - RED

PLUG-IN HARNESS (20581) BLADE TERMINAL TO PLUG-IN ADAPTER (20589) YELLOW WIRE

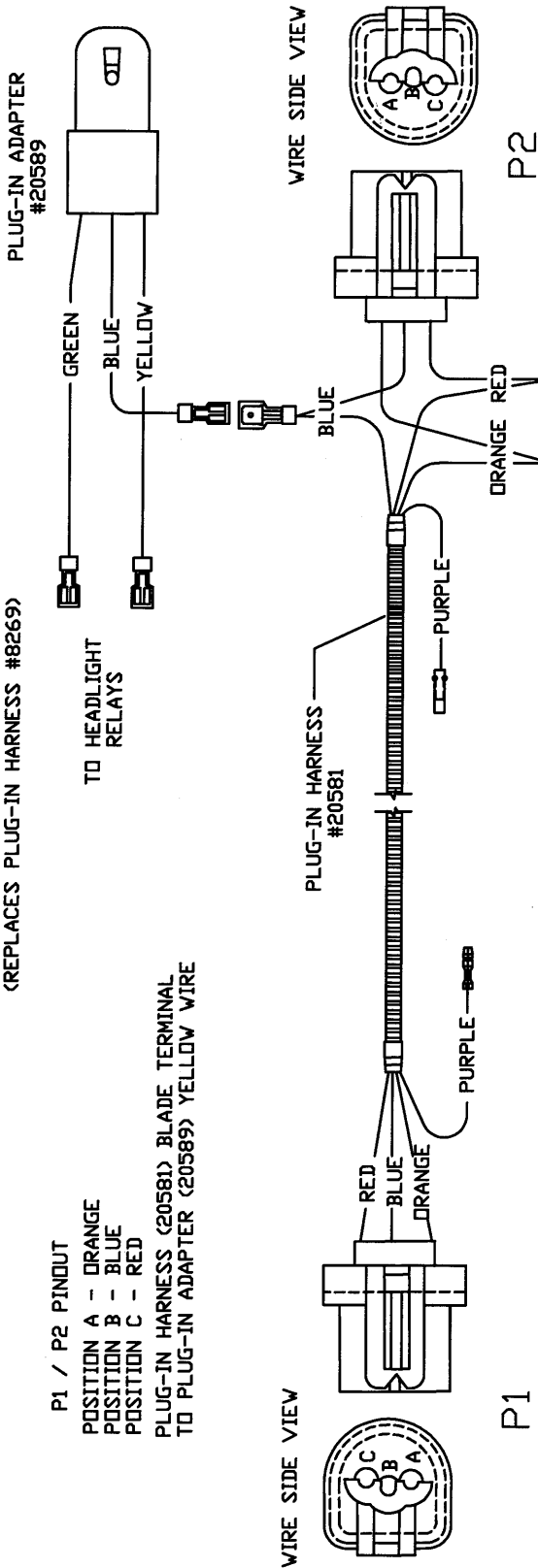

INSERTING SOCKETS (P1/P2)

- 1) PLACE LOCKING TAB DOWN.
- 2) PUSH SOCKET INTO CORRECT CAVITY AND LISTEN FOR A CLICK.
- 3) LIGHTLY TUG ON WIRE. IF WIRE SHOULD PULL OUT THE LOCKING TAB MAY NEED TO BE BENT OUTWARD. BEND TAB AND REINSTALL.

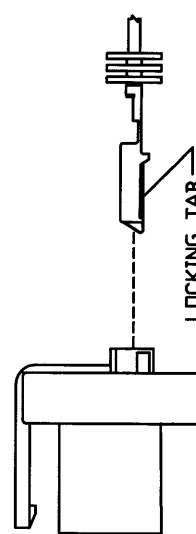

ILL21302R1

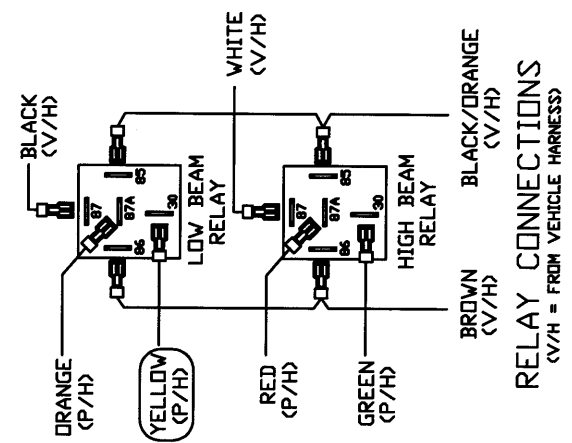

FORD/MAZDA HB-1 HEADLIGHTS

(REPLACES PLUG-IN HARNESS #8266)

P1 / P2 PINOUT

- POSITION A - BLUE
- POSITION B - ORANGE
- POSITION C - RED

PLUG-IN HARNESS (20581) BLADE TERMINAL TO PLUG-IN ADAPTER (20589) BLUE WIRE

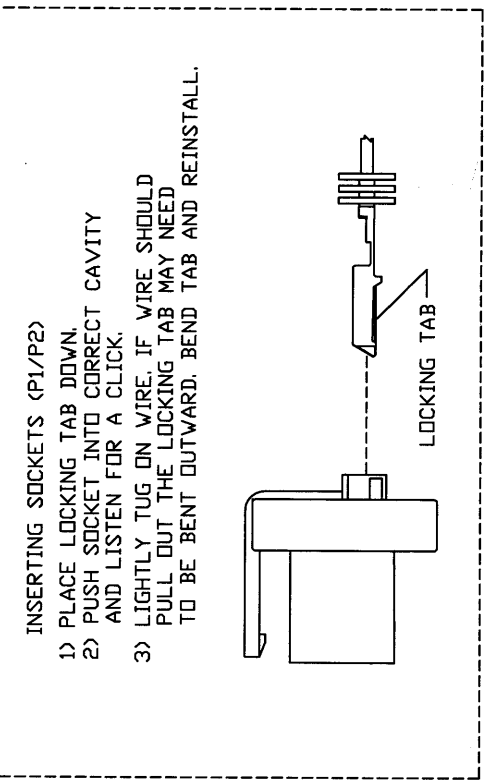
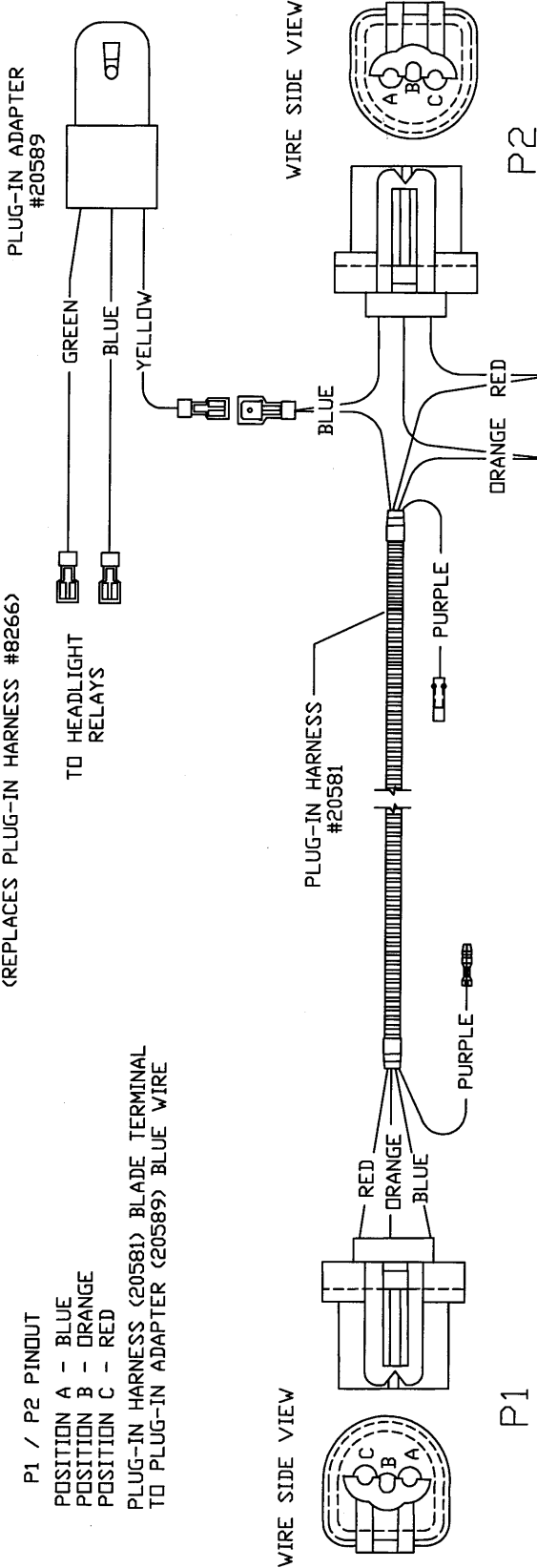

ILL21303R1

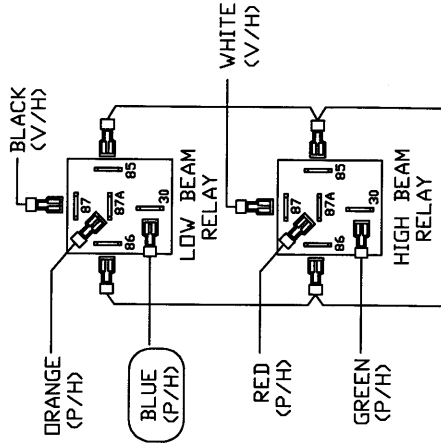

BROWN (V/H)
BLACK/ORANGE (V/H)

RELAY CONNECTIONS
(V/H = FROM VEHICLE HARNESS)
(P/H = FROM PECULIAR HARNESS)