



**Fisher Engineering**

P.O. Box 529, Rockland, ME 04841

# 8903 Peculiar Harness Dodge HB-1 Headlights

October 28, 1997

No. 22103

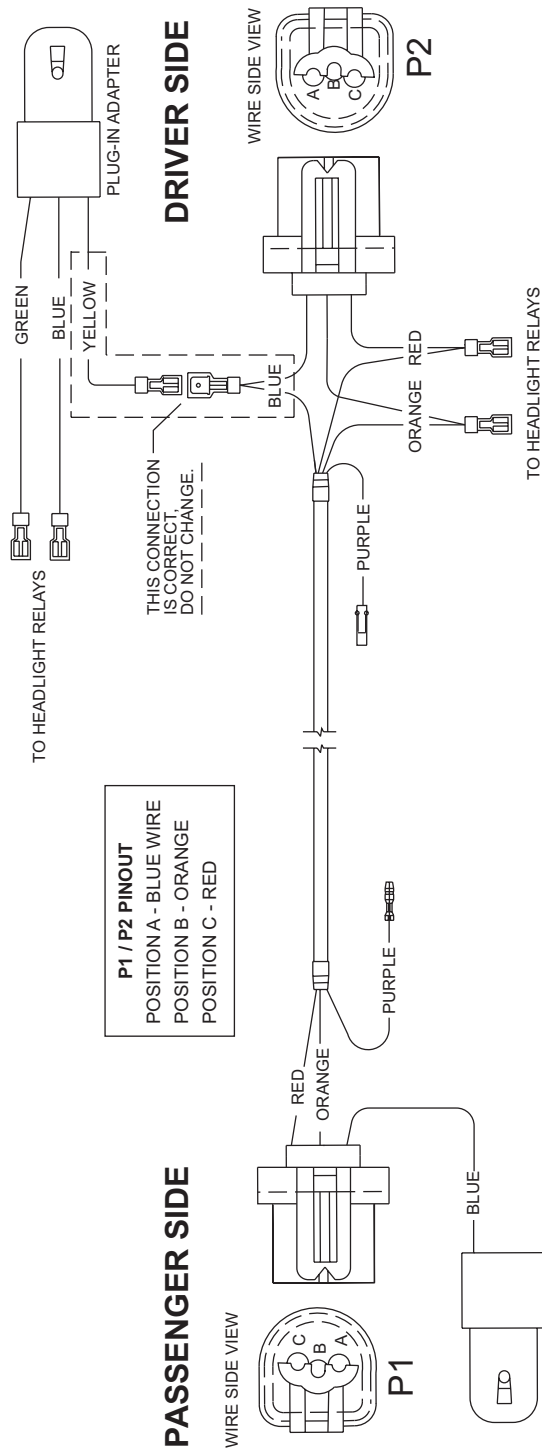

**P1 / P2 PINOUT**  
 POSITION A - BLUE WIRE  
 POSITION B - ORANGE  
 POSITION C - RED

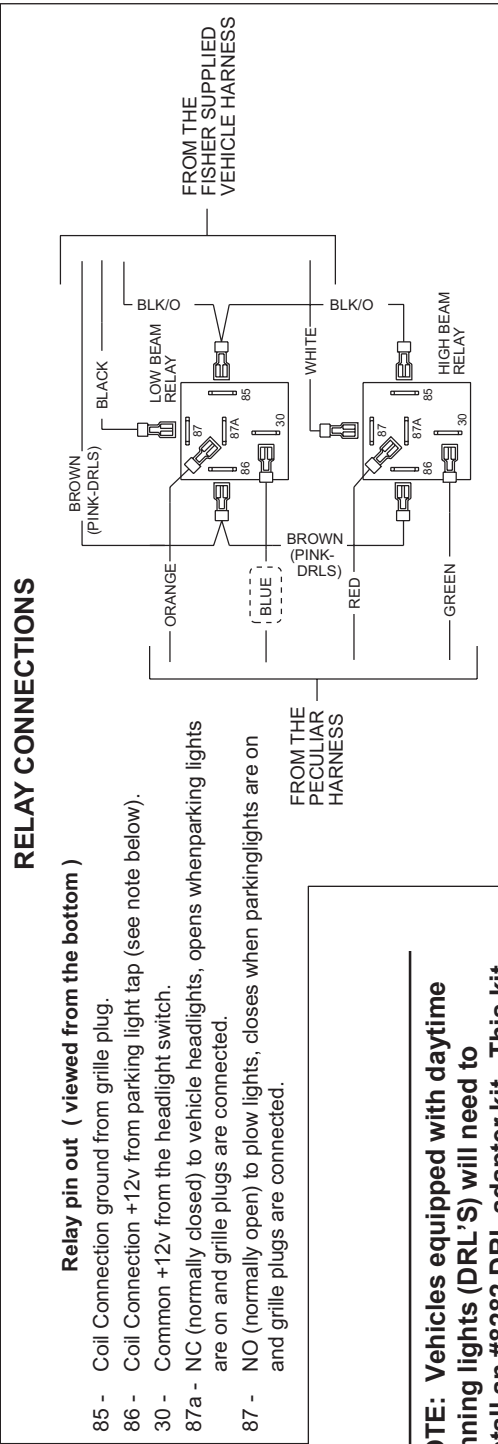

## RELAY CONNECTIONS

**Relay pin out ( viewed from the bottom )**

- 85 - Coil Connection ground from grille plug.
- 86 - Coil Connection +12v from parking light tap (see note below).
- 30 - Common +12v from the headlight switch.
- 87a - NC (normally closed) to vehicle headlights, opens when parking lights are on and grille plugs are connected.
- 87 - NO (normally open) to plow lights, closes when parking lights are on and grille plugs are connected.

**NOTE: Vehicles equipped with daytime running lights (DRL'S) will need to install an #8282 DRL adapter kit. This kit will replace the brown wires on the relays, terminal #86. The relays will now be powered from a switched accessory line, terminal #86 (+12V only when the ignition switch is in the ON position).**

Fisher Engineering reserves the right under its product improvement policy to change construction or design details and furnish equipment when so altered without reference to illustrations or specifications used herein. Fisher Engineering and the vehicle manufacturer may require and/or recommend optional equipment for snow removal. Fisher Engineering offers a limited warranty on all snowplows, spreaders and accessories. See separately printed page for this important information. The following are registered (®) and unregistered (™) trademarks of Douglas Dynamics, L.L.C.: FISHER®