



PARTS & INSTALLATION INSTRUCTIONS

EZ MOUNT XPRESS®

AG-7.5 thru AG-9.0 SNOW PLOWS



PARTS LIST

Item	Part No.	Part No.	Part No.	Part No.	Qty.	Description
	AG-7.5	AG-8.0	AG-8.5	AG-9.0		
1	09200	09205	09220	09215	1	AG Moldboard Assy.
2	09796	09133	09134	07259	1	• Cutting Edge
3	08184	-----	-----	-----	1	• Bolt C 1/2-13 x 1-3/4" Gr.5 & Locknut (Kit of 9)
3	-----	08692	08692	-----	1	• Bolt C 1/2-13 x 2" Gr.5 & Locknut (Kit of 10)
3	-----	-----	-----	08318	1	• Bolt C 1/2-13 x 2-1/4" Gr.5 & Locknut (Kit of 12)
4	12394	12394	12394	12394	2	• Mushroom Shoe Casting Assy.
5	12449	12449	12449	12449	2	• Runner Spacer
6	20363	20363	20363	20363	22	• Runner Washer
7	22083	22083	22083	22083	2	• Lynch Pin
Item	Part No.		Qty.	Description		
		16535	1	EZ Mount Xpress® PAF		
8		19180	1	• Stand Clevis Weldment		
9		19175	1	• Hook Weldment w/ Light Brackets		
10		13735	1	• Xpress Push Frame		
11		13740	1	• Rear Push Frame		
12		12360	1	• Pivot Bar		
13		19358	1	• RH Hook Coated		
14		19359	1	• LH Hook Coated		
15		19357	1	• Ram Adjustment Cap		
16		19190	1	• Lift Arm		
17		811000095	2	• Plow Marker		
18		07017	4	• Trip Spring		
		07293	1	• Mount Ram Assy. 2-1/4 x 15 DA SAE		
19		05871	1	•• Ram 2-1/4 x 15 DA SAE		
20		22420	1	•• Hose Assy. 1/4 x 33" M x M SAE-6		
21		22420	1	•• Hose Assy. 1/4 x 33" M x M SAE-6		
22		22443	1	•• Female Coupler SAE-6 (OPTIONAL)		
23		22444	1	•• Male Coupler SAE-6 (OPTIONAL)		
24		22460	1	•• Elbow 90 Degree M x F SAE-6		
		08797	1	• HARDWARE BAG		
25		22507	2	•• Chain Holder		
26		819000001006	2	•• Pin		
27		09124	4	•• Eyebolt w/Locknut & Cap		
28		07288	1	•• 1-3/4" Xpress® Lock		
29		20006	2	•• Bolt H 1/4-20 x 1-1/4" Gr. 2		
30		20027	4	•• Bolt H 5/16-18 x 1" Gr. 2		
31		20145	1	•• Bolt H 5/8-11 x 3" Gr. 5		
32		20500	1	•• Bolt H 5/8-18 x 4" Full Thread		
33		22402	1	•• Bolt H 5/8-11 x 12" Gr. 5		
34		22272	1	•• King Bolt H 1-8 x 6-1/2 w/ Grease Fitting		
35		22273	1	•• Pivot Bolt H 1-8 x 6-1/2		
36		22331	1	•• Hex Head Pin 1 x 3-5/16"		
37		22375	2	•• Pivot Pin W/Grease Fitting 1 x 8-3/4"		
38		22398	1	•• King Pivot Bolt W/Grease Fitting 1-8 x 5-1/2"		
39		20303	2	•• Locknut Esna 1/4-20		
40		20304	8	•• Locknut Esna 5/16-18		
41		20309	2	•• Locknut Esna 5/8-11		
42		20544	1	•• Hex Nut 5/8-18		
43		22274	3	•• Slotted Hex Nut 1-8		
44		20331	1	•• Lockwasher 5/8		
45		20352	4	•• Flatwasher 5/16		
46		21259	6	•• Flatwasher 5/8 SAE		
47		20420	8	•• Cotter Pin 1/4 x 2"		

Parts indented are included in the carton, bag or assembly under which they are indented.

Meyer Products Inc. and Diamond Equipment reserves the right, under its continuing product improvement program, to change construction or design details, specifications and prices without notice or without incurring any obligation.

Meyer Products Inc.
18513 Euclid Ave. • Cleveland, Ohio 44112-1084
Phone 486-1313 (Area Code 216)
email • warranty@meyerproducts.com

Diamond Equipment
6 Angell Lane • Damariscotta, ME 04543-9720
Phone 563-2227 (Area Code 207)
www.diamondplow.com • email info@diamondplow.com



Meyer Products assumes no responsibility for installations not made in accordance with these instructions.

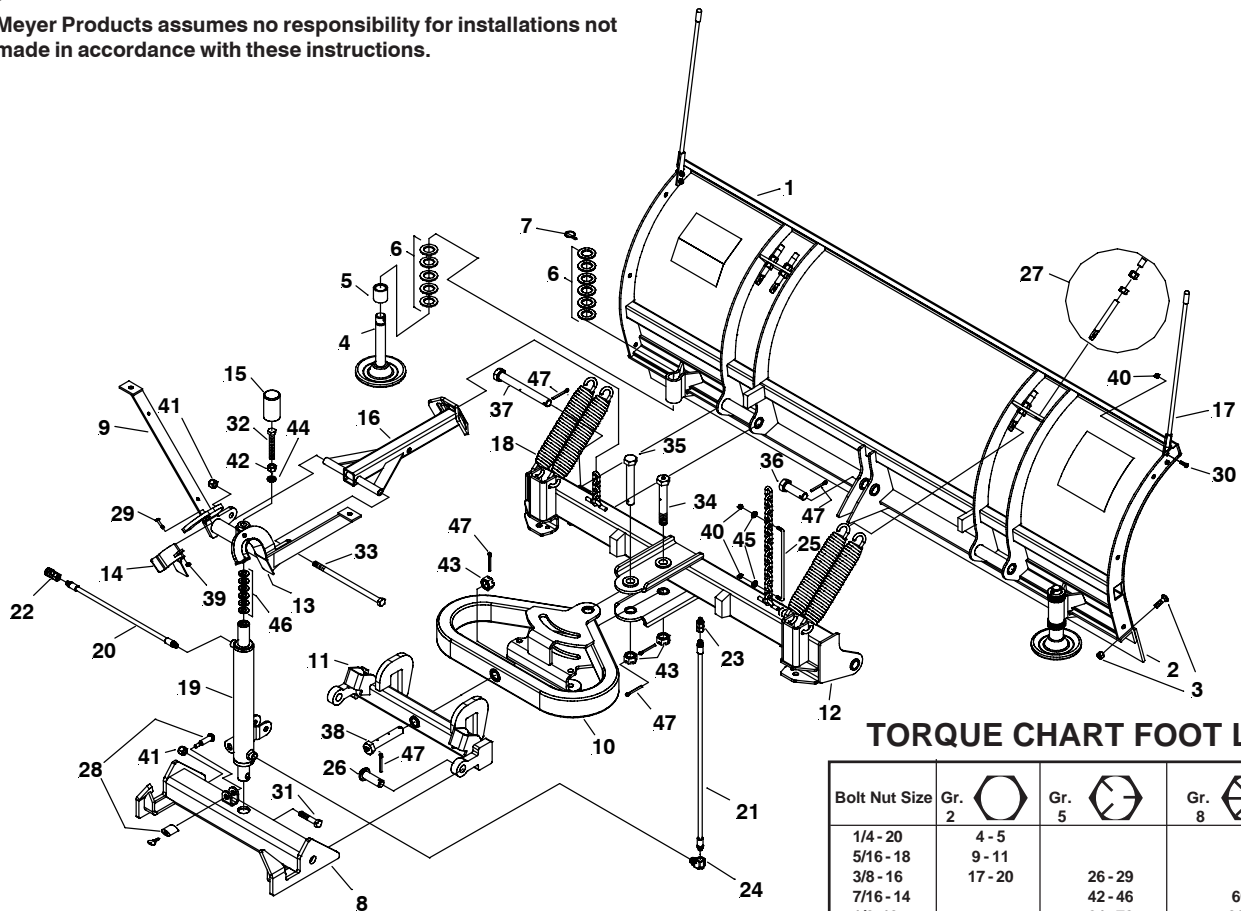

*Truck shown with optional light guards.

SUGGESTED ORDER OF NEW PLOW INSTALLATION

1. Vehicle specific mounting instruction - Form Varies
2. Snow plow assembly - Form 1-839 (Current Form)
3. Hydraulic/ lights / controls install - Form 1-820
4. Operation and Maintenance Manual - Form 4-611

SNOW PLOW ASSEMBLY INSTRUCTIONS

- A. Have Moldboard Assembly (1) face down for steps A to D. Install Pivot Bar (12) to Moldboard Assy. (1) using one 1 x 8-3/4" Pivot Pin w/ grease fitting (37) and Cotter Pin (47) on each end. Install 1 x 3-5/16" Pivot Pin (36) with Cotter Pin (47) in the center.
- B. Hardware in step B refers to item (27) in diagram. Thread one 3/4"-10 regular nut about half way down each of the eyebolts. Slip a eyebolt assembly over one end on each of the Springs (18). Insert the opposite end of the Springs (18) onto Pivot Bar (12) holes per illustration. Raise the pivot bar up so the eyebolts can be inserted into each of the four holes on the plow spring plates. Secure eyebolts by adding one 3/4-10 Locknut on the ends and tighten springs so that there is enough tension to slip a sheet of paper in between the coils. Once the tension is good in all four springs, tighten the 3/4-10 regular nuts up against the bottom plow spring plates. **Note: Make sure spring hooks are perpendicular to eyebolts so that the hooks can rotate freely while plow is tripping. Complete spring install by placing a vinyl cap over the end of each eyebolt.**
- C. Install nose hole of Pushframe (10) to the front hole of Pivot Bar (12) using the 1"-8 x 6-1/2" Pivot Bolt w/ grease fitting (34), Slotted Hex Nut (43), and Cotter Pin (47). Install the 1"-8x 6-1/2" pivot bolt (35) through the rear holes on Pivot Bar (12) and Pushframe's (10) slots and attach using a Slotted Hex Nut (43), and Cotter Pin (47). **Note: Tighten all Slotted Hex Nuts (43) one slot past snug and install and bend Cotter Pins (47) to prevent the nut from coming loose.**
- D. Position hook ears on Rear Pushframe (11) over the rear tube section on Pushframe (10) and attach using a 1" x 5-1/2" Bolt w/ grease fitting (38), Slotted Hex Nut (43), and Cotter Pin (47). See note from step C.
- E. For ease of assembly, install Power Angling Cylinders (In Hydraulic Carton) with the plow face down. Reference Form 1-820.
- F. Tilt current plow assembly back upright.
- G. Align plow markers (17) to the inside of plow's end ribs and attach using two 5/16-18 x 1" Bolts (30) and 5/16-18 locknuts (40) on each side.
- H. Start new subassembly by installing the live end of Mount Ram Assy (19) into Stand Clevis Weldment (8). Align holes and attach with a 5/8-11 x 3" Bolt (31) and 5/8-11 Locknut (41). **Note: This assembly is meant to be close in tolerance, in some cases excess paint may need to be removed from the live end of the cylinder to fit.**
- I. Place three out of six 5/8 SAE Washers (46) on top of Mount Ram Assy (19). The three may need to be adjusted later in the install. Slip Top Hook Weldment (9) over Washers (46) and Mount Ram (19). **Note: This assembly is meant to be close in tolerance, in**

some cases some excess paint may need to be removed from the top of the cylinder to fit. Thread the 5/8-11 Hex Nut (42) most of the way up the 5/8-18 x 4" Full Thread bolt (32). Slip the 5/8 lockwasher (44) over the bolt assy and thread through the center hole on the Top Hook Weldment (9) and into the top of the Mount Ram (19). Snug Bolt (32) and then Nut (42) with a wrench. Insert Ram Adjustment Cap (15) over bolt assembly.

- J. Insert LH & RH Coated Hooks (13/14) into the hooks of the Top Hook Weldment (9). Align the tabs with the holes and attach using a 1/4-20 x 1-1/4" bolt (29) and 1/4-20 locknut (39).
- K. Align Lift Arm (16) in-between the top hook weldment's ears and attach using a 5/8-11 x 12" bolt (33) and 5/8-11 locknut (41).

⚠ WARNING

Xpress Lock Pin (28) **MUST** be installed through the stand clevis (8) u-clip and the mount ram (19) tab when plow is attached to vehicle. This is a safety feature that insures the stand clevis stays attached to the Lift Frame at all times (See Mount Instructions).

Xpress Lock Pin (28) can also be installed when plow is removed with the mount ram collapsed. **Both on and off the vehicle, the Xpress Lock Pin (28) will help prevent theft.**

- L. Align the Rear Push Frame (11) ears to the outer side plate holes on stand clevis (8) and attach using Pin (26) with Lynch Pin (48) on each side. **Note: After the ears have been inserted, it may be easier to install Pins (26) by tilting the stand assembly back away from the plow to give more room for hands. Pins (26) may be installed from the inside or outside.**
- M. Refer to Form 1-820 for hydraulic and electrical installation, then finish step N & O.
- N. Install one end of Chain Holders (25) to the first link of chain welded to Pivot Bar (12) and the opposite end to the closest possible link on chain keeping it taught. Attach both ends using 5/16 Flatwasher (44) and 5/16 Locknut (40). Install both lift chains through the two hooks on the Lift Arm (16). Adjust the lift chains so that they have no slack when the Lift Arm (16) is parallel to the ground. The moldboard should not begin to raise until the lift arm is parallel with the ground. This ensures that the lift arm cannot interfere with the back of the moldboard. This also ensures the plow blade will lift fully and be able to follow the ground contour while plowing.
- O. When clamping the Mount Ram (19) to the truck to the first time. Make sure the assembly clamps fully; you will see a small amount of flex in the top tube on the lift frame. If there is too much or no flex, refer back to Step H, you may need to add (with up to 3 extra washers (45)), or remove some of the 3 washers (46) to get a tight fit on the truck.

⚠ WARNING



Read the Meyer Owner's Manual before operating or servicing a snowplow. **FOLLOW THESE INSTRUCTIONS EXPLICITLY.**