



# **FAST-CAST SERIES SPREADERS**

**Assembly and Owner's Manual - September 2010**

**Fast-Cast 2000 (1CS1), Fast-Cast 300 (1CS9), Fast-Cast 400 (1CS10)**



**IMPORTANT:** *Before you Start...*

- ▶ Before attempting any procedure in this manual, these safety instructions must be read and understood by all workers who have any part in the preparation or use of this equipment.
- ▶ For your safety, warning and information decals have been affixed to this product to remind all operators of safety precautions. If decals are marked, damaged or destroyed, replace with new decals ordered from Curtis Industries, LLC.

**WARNING**

- ⇒ 1. **Most accidents are preventable and caused by human error.**  
Exercise care and precautions to prevent the possibility of injury to operator or to others.
- ⊘ 2. **Never operate equipment when under the influence of alcohol, drugs or medication that might alter your judgement and / or reaction time.**
- ⚠ 3. **Before working with the Spreader, secure all loose fitting clothing and unrestrained hair.**
- ⚠ 4. **Always wear safety glasses with side shields when working metal against metal. Failure to do so could result in serious injury to the eyes.**
- ⊘ 5. **Never allow children to operate or climb on equipment.**
- ⊘ 6. **Never weld or grind on equipment without having a fire extinguisher available.**
- ⇒ 7. **Always check areas to be spread to be sure no hazardous conditions or substances are in the area.**
- ⇒ 8. **Always inspect unit for defects: Broken, worn or bent parts, weakened areas on Spreader or Mount.**
- ⇒ 9. **Always shut off vehicle and power source before attempting to attach or detach or service Spreader unit. Be sure vehicle/power source is properly braked or chocked.**
- ⚠ 10. **Always make sure personnel are clear of areas of danger when using equipment.**
- ⚠ 11. **Always keep hands, feet, and clothing away from power-driven parts.**
- ⇒ 12. **Remember, it is the owner's responsibility to communicate information on safe usage and proper maintenance of all equipment.**

1CS9 • Fast-Cast 300



- Rock Salt, Deicers
- Light Duty Grade Applications
- 3.0 Cu. ft./180 lb. Capacity
- 4 to 20 ft. Spreading Width
- 7-10 Amperage Draw

1CS10 • Fast-Cast 400



- Fine Material Applications
- 3.0 Cu. ft./180 lb. Capacity
- 4 to 20 ft. Spreading Width
- 7-10 Amperage Draw

**! CAUTION**

- Never exceed 45 m.p.h. when loaded spreader is attached to vehicle. Braking distances may be affected and handling characteristics may be impaired at speeds above 45 m.p.h.
- Never use wet materials, or materials with foreign debris in the Fast-Cast Spreaders. These units are designed to handle dry, clean, free-flowing material.



**NOTE** Curtis Spreaders can not spread water softener salt.

- Never leave material in Hopper for long periods of time. Be aware that all ice melters are hygroscopic and will attract atmospheric moisture and harden up.
- Always inspect pins, and latches whenever attaching or detaching Spreader, and before traveling.
- Inspect the unit periodically for defects. Parts that are broken, missing, or worn out must be replaced immediately. The unit, or any part of it should not be altered without prior written permission from the manufacturer.

1CS1 - Fast-Cast 2000



- Rock Salt, Deicers
- Free-Flowing Materials
- 5.0 Cu. ft./350 lb. Capacity
- 4 to 40 ft. Spreading Width
- 12-15 Amperage Draw

## Sno-Pro Fast-Cast Series Spreaders

### SECTION 1. SPREADER WIRING STEPS (Refer to Page 17)

- 1a. The Harness Assembly will be routed from the rear of the vehicle to the front. Route Harness along frame and attach to frame holes and frame supports.



#### WARNING

**It is not recommended to attach to fuel or brake lines for obvious reasons.**

Do not route close to exhaust system or engine, even though Curtis uses high temperature wiring, the wiring could still melt under extreme heat and short the spreader electrical system, as well as the vehicle electrical system.

- 1b. Mount Rear Plug on bumper using supplied bolts. Locate towards the center of the bumper to reduce the amount of debris the tires will throw to the rear.

#### IMPORTANT

**Apply a small amount of dielectric grease to the plug.**

- 1c. Secure Harness from the rear to the front using heavy duty tie-wraps or frame clips along the frame and lighter duty tie-wraps in all other locations.
- 1d. Layout Harness portion that connects to the battery along the fire wall and fender well. Do not connect power leads to Battery at this time. Drill a 3/4" hole in the fire wall, or use existing access hole, for the control portion of the Harness and route connector and Harness through hole. Be sure to check the area on the other side of the fire wall to be certain that you are not going to drill into the vehicle harness or a Control Module. Generally you can drill on either side of the steering wheel for a good location.
- 1e. Connect Harness to the back of the Controller and mount to a suitable location.



#### NOTE

**You may want to contact customer before mounting controller, some prefer not to have holes drilled into the dashboard.**

Tie-wrap loose Controller Harness and move to the vehicle engine compartment.

- 1f. Connect power leads to the **Battery: Red (+) Positive, Black (-) Negative.** Always connect to the primary Battery if using a Dual Battery System. Secure loose loom to any other large or medium vehicle harness with medium duty tie-wraps; this will secure wiring Harness.

- 1g. Install ignition wire to an auxiliary circuit that is hot when the ignition key is turned to ON position. This wire is 60" long and has a female terminal attached to it. This wire will plug into back of Controller. This wire must be installed in order for Controller to operate.

- 1h. Push the ON/OFF button on the Controller to check for power, when that has been confirmed turn power OFF. The electrical portion of the installation is complete.



#### NOTE

**If adding an inline fuse, use a 35 amp slow blow fuse on Fast-Cast 2000 only.**

### SECTION 2. OPERATING THE SPREADER

#### 2a. PREPARATION



#### CAUTION

Sweep area clear of foreign objects or obstacles that could cause personal injury. Keep other persons, children, or animals out of the area to be spread.

#### 2b. SPREADER LOADING



#### WARNING

**Do not overload vehicle. Rock Salt weighs 35-40 pounds per cubic foot. Maximum weight of materials for the Fast-Cast 2000 is 350 lbs. for a pickup truck, and 250 lbs. for a UTV mounted Spreader.**

#### IMPORTANT

**Always comply with manufacturer's maximum gross vehicle weight ratings.**



#### CAUTION

**Never leave materials in Hopper for long periods of time as salt is hygroscopic and will attract atmospheric moisture and harden up.**

## Sno-Pro Fast-Cast Series Spreaders

### 2c. SPREADER LOADING TIPS

- ▶ Never exceed 10 m.p.h. when spreading.
- ▶ For a wider pass, increase Spinner speed.
- ▶ For a heavier pass, drive slower.
- ▶ Never operate Spreader near pedestrians.
- ▶ Spread ice melters with the storm to prevent unmanageable levels of ice.
- ▶ Calculate spread pattern when near vegetation.

### 2d. FAST-CAST 2000 OPERATION

- (1.) The Variable Speed Controller has finger-tip dial action.
- (2.) To Start, press Power Switch on Controller and Spreader will accelerate to speed set on dial.
- (3.) To Stop, press Power Switch on Controller to off position.
- (4.) Adjust speed of Spinner by using dial on right side of Controller.

## SECTION 3. FAST-CAST 400 ASSEMBLY STEPS (Refer to Page 12)

- 3a. Attach Hopper Tube Support (17) to Transmission Weldment (18) using four 5/16"-18 x 1-3/4" Hex Bolts (11) and four 5/16" Lock Nuts (3) Use the four bottom mounting holes at ends of Hopper Tube Support (17).
- 3b. Locate Spreader Gate Deck (15) and place upside down on a flat work surface.
- 3c. Assemble Gate Indicator/Stop (12) on Stop Slide with Gate Knob (7). Gate Indicator/Stop must be on the inside of Gate Deck where it will stop the track.
- 3d. Insert one 5/16" Bolt with hole (10) through Gate Indicator/Stop (12). Hand tighten one 5/16" Lock Nut (3) on Bolt.
- 3e. Locate Bulkhead Cable Fitting (9). Thread onto T-Handle Cable-20' (8) rubber coating.
- 3f. Insert Cable assembly through Tab on Gate Deck. Secure with supplied Washer and Nuts.



#### NOTE

**A Nut must be positioned on both sides of tab on Gate Deck.**

3g. Turn over Gate Deck and lower the assembly over the Spinner Shaft. The Spinner Shaft must be inserted through the 5/8" hole on Gate Deck.

3h. Fasten Gate Deck to Hopper Tube using four 5/16" Hex Bolts (11) and four 5/16" Lock Nuts (3).



#### NOTE

**First tighten bottom bolts, pull front of Gate Deck up, then tighten top set of bolts.**

3i. Place Hopper (16) on Gate Deck and over the Spinner Shaft.

3j. Hand tighten the two 5/16"x 1" Bolts (5) inserted through bottom of Hopper.

3k. Place one Fender Washer (1) over each of the four Hex Bolts (11). Insert the four Bolts with Fender Washers through Hopper back and through Tube Support. Secure with four 5/16" Locknuts (3).

3l. Fully tighten the two Bolts in bottom of Hopper that secure the Hopper to the Deck installed in Step 3j.



#### NOTE

**Refer to Page 13 for the following Steps.**

3m. Position Agitator (11) on Spinner Shaft. Tighten to middle of flat with short allen key.

3n. Attach Receiver Mount (18) to Transmission Weldment (17) using four 1/2" Hex Bolts (19) and four 1/2" Lock Nuts (20).

### CABLE INSTALLATION STEPS

3o. Mount Spreader on vehicle in its permanent location. Insert Hitch Pin in hitch to prevent unit from moving.

3p. Route T-Handle to desired operating location. There cannot be any bends or sharp corners in the Cable.

3q. Take T-Handle out of Sleeve. Take Nuts and Washer off Sleeve.

3r. Drill a 1/2" diameter hole to mount T-Handle. Thread one supplied Nut and Washer on Cable after inserting through drilled hole.

3s. Completely close the Gate Slide.

3t. Re-insert Cable Handle and wire all the way until the Handle portion of T-Handle Cable (8) contacts Bulkhead Cable Fitting (9). Aim through Bolt with hole (10) and tighten Bolt.

## Sno-Pro Fast-Cast Series Spreaders

### SECTION 4. FAST-CAST 300 ASSEMBLY STEPS (Refer to Page 10 & 11)

- 4a. Attach Hopper Tube Support (6) to Complete Drive Assembly using four 5/16"-18 x 1-3/4" Hex Bolts (3) and four 5/16" Lock Nuts (2). Use the four bottom mounting holes at ends of Hopper Tube Support.
- 4b. Locate Auger (11) and set on a flat work surface to tap one black plastic Cap into tube between Auger uprights if not already installed.
- 4c. Place Auger on Shaft of Transmission and tighten to top of flat with one Set Screw (8).
- 4d. Place Salter Throat Deck (5) over Auger and between Hopper Tubing Support.
- 4e. Using four 5/16"-18 x 1-3/4" Bolts (3) and (4) 5/16" Lock Nuts (2), hand tighten through upper set of holes on Tube Support.
- 4f. With 1/2" wrench and socket, tighten bottom set of bolts on Throat Deck.
- 4g. Lift up on Throat Deck at the front (Auger hole side) to level Deck. Tighten top set of Bolts.
- 4h. Place Hopper Throat (4) through Deck around Auger. Holes in Hopper should line up with holes in Tube Support.
- 4i. Place one 3/8" Fender Washer (1) on all four 5/16" Hex Bolts (3). Insert through Hopper, and through tube, then secure with a 5/16" Nut (2) on back of unit. Tighten.
- 4j. Attach Receiver Mount (7) to Transmission Weldment (17) using four 1/2" Hex Bolts (19) and four 1/2" Lock Nuts (20).
- 4k. Insert Receiver Tube end into Receiver Hitch and secure with Hitch Pin (2).
- 4l. Wire Spreader according to wiring instructions found on Page 17.

### SECTION 5. FAST-CAST 300 / 400 WIRING STEPS (Refer to Page 17)

- 5a. Install Switch/Control at desired location.
- 5b. Run Spreader Vehicle Harness from the rear of vehicle to Switch/Control area.  
Attach the **female spade/red wire to the switch or the positive (+) output connection** of the Control.  
If using Control, attach the **male spade/black wire on the negative (-) output connection** of the Control.  
If using Switch, leave the black wire for Step 5e.
- 5c. Route the Power Harness from the Battery to the Switch/Control.
- 5d. Attach the **red lead to the positive side (+) of the Battery** and the **black lead to the negative side (-) of the Battery**.
- 5e. If using the Control, attach the **female spade red lead from the Power Harness to the Battery positive (+) terminal**.  
Attach the **male spade black wire to the Battery negative terminal (-)**. If using Switch, attach the female spade red wire on Switch Terminal.  
Using 3" double female black wire jumper, attach the black wire from the Power Harness to the black wire of the vehicle harness.
- 5f. Install Rubber Weatherproof Boot on Switch before finishing installation.
- 5g. Apply Dielectric Grease to terminals of SAE Plug at rear of vehicle.

### SECTION 6. TROUBLESHOOTING

Whenever service is necessary, your local dealer knows your Curtis Spreader best. Take your Curtis Spreader to your local dealer for any maintenance or service needs on your unit. If this is not possible, the Troubleshooting Guide on the next page may assist you in identifying the problem.



#### **WARNING**

**First read all Warning instructions and Safety messages on Pages 2 & 3 before servicing your Spreader.**

#### **Preliminary Checks**

- ▶ Check that all electrical connections are tight and clean.
- ▶ Check that nothing is jammed in the Hopper.

## Sno-Pro Fast-Cast Series Spreaders



### CAUTION

Always shut off vehicle and power source before attempting to attach or detach or service Spreader unit. Be sure vehicle / power source is properly braked or chocked.



### DANGER

Always keep hands, feet, and clothing away from power-driven parts.

## SECTION 7. SPREADER MAINTENANCE



### WARNING

When servicing is necessary, perform it in a protected area. Do not use power tools in rain or snow because of danger of electrical shock or injury. Keep area well lighted. Use proper tools. Keep the area of service clean to help avoid accidents.



### WARNING

Disconnect electricity to Spreader before servicing. The Controller is a solid state electronic unit and is not serviceable.



### CAUTION

Any attempt to service Controller will void warranty.

### IMPORTANT

Use Dielectric Grease on all electrical connections to prevent corrosion at the beginning and end of the season and each time power plugs are disconnected.

### IMPORTANT

Wash unit after each use to prevent material build-up and corrosion.



### NOTES

When pressure washing motor enclosure area, stay at least 36" away from motor enclosures.



Paint or oil all bare metal surfaces at the end of the season.



Apply small amount of light oil to latches as needed.



### MORE NOTES

If motor cover is removed for any reason, use silicone sealant to ensure weather proofing of enclosure.



After first use, tighten all nuts and bolts on Spreader and mount.

PROBLEM	POSSIBLE CAUSE	SOLUTION
Motor Doesn't Run	Loose Electrical Connections	Check All Connections
	Blown Fuse	Replace Fuse
	Motor Seized	Replace Motor
Controller Shut Down	Jammed Auger	Carefully Clear Jammed Material
	Poor Electrical Connections	Clean or Replace Connectors Use Dielectric Grease
	Electrical Short	Check Electrical Connections Check for Bare Wires
Material Not Flowing	Controller Failure	Replace Controller
	Empty Hopper	Fill Hopper
	Wet Material	Replace With Dry Material
	Frozen or Coarse Material	Replace Material
	Spinner Not Turning	Check Drive Assembly
	Auger Loose on Shaft	Tighten Locking Bolt on the Side of Auger. Align Auger with Flat Side of Driver Shaft and Tighten Bolt.

# Sno-Pro Fast-Cast Series Spreaders

## 1CS1 Fast-Cast 2000 - Illustrated Parts List

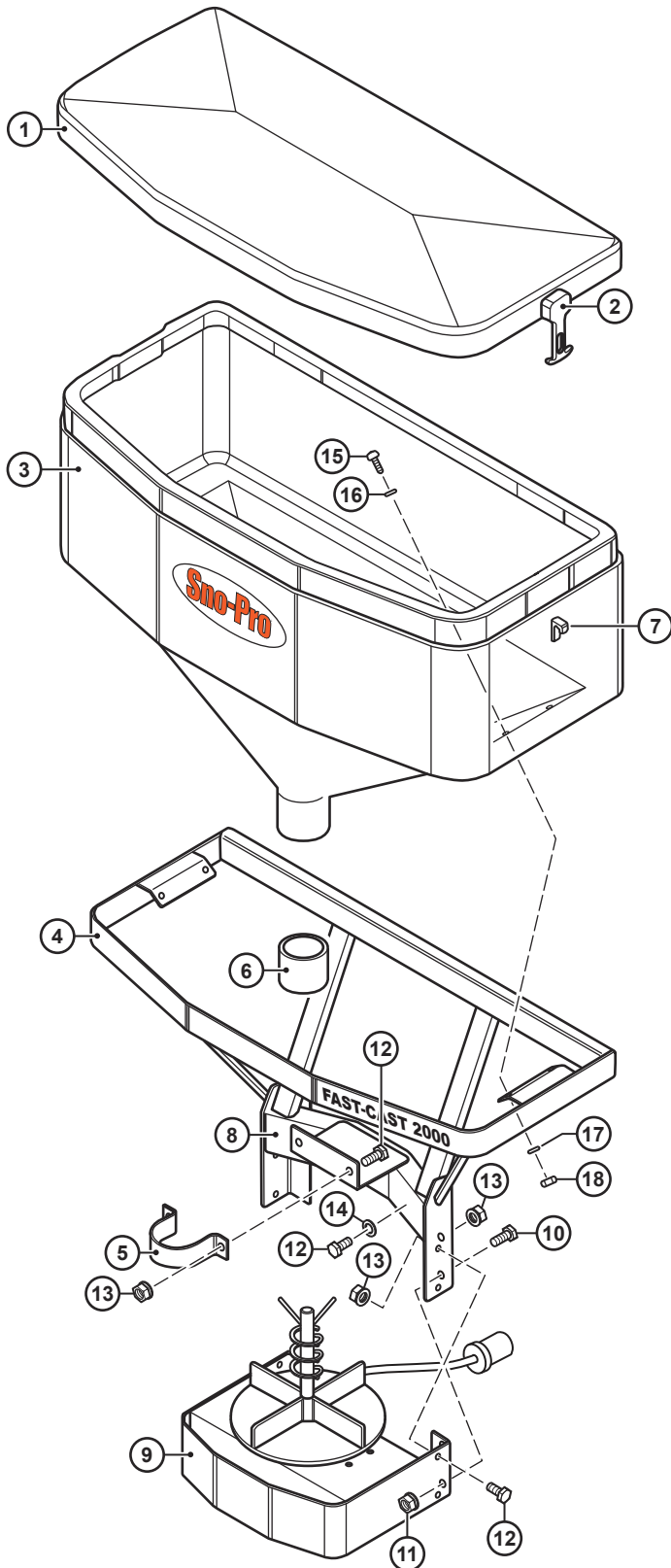

Item No.	Part No.	Description	Qty.
1	1CS1P1	Lid With Latches	1
2	1CS1P2	Flexible Draw Latch	2
3	1CS1P3	Hopper	1
4	1CS1P4	Main Frame	1
5	1CS1P5	Throat Clamp	1
6	1CS1P42	Stainless Throat Liner	1
7	1CS1P48	Latch Keeper	2
8	1CS1P12	Deflector 20"	1
9	1CS1P49	Complete Drive Assembly	1
10	1CS1P10	1/2"-13 x 1-1/2" Hex Bolt	4
11	1CS1P11	1/2"-13 Lock Nut	4
12	1CS1P8	3/8"-16 x 1" Hex Bolt	8
13	1CS1P9	3/8"-16 Lock Nut	8
14	1CS1P41	3/8" Flat Washer	2
15	1CS1P6	5/16"-18 x 1-1/4" Phillips Bolt	2
16	1CS1P47	3/8" S/S Washer	2
17	1CS1P46	5/16" Lock Washer	2
18	1CS1P7	5/16"-18 Hex Nut	4

### Optional Mount Required for Fast-Cast 2000 Spreader

Item No.	Part No.	Description	Qty.
19	1SM2P1	2" Receiver Hitch	1
20	1SM1P2	5/8" x 5-1/2" Hitch Pin	1
21	1SM1P3	2-5/16" Hair Pin Clip	1

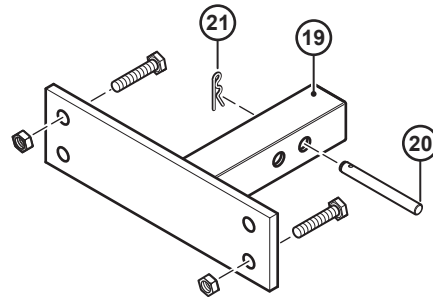

# Sno-Pro Fast-Cast Series Spreaders

## 1CS1 Fast-Cast 2000 Complete Drive Assembly - Illustrated Parts List

Item No.	Part No.	Description	Qty.	Item No.	Part No.	Description	Qty.
1	1CS1P16	Motor 12 Volt DC	1	9	1CS1P25	1/4"-20 x 3/4" Hex Bolt	4
2	1CS1P53	Transmission	1	10	1CS1P24	5/16"-18 x 1/2" Hex Bolt	1
3	1CS1P17	Motor Cover	1	11	1CS1P30	1/4" Lock Washer	4
4	1CS1P13	Drive Enclosure	1	12	1CS1P27	#10-32 x 5/8" Cap Screw	2
5	1CS1P21	Fast-Cast 2000 Power Cable	1	13	1CS1P28	#10 Lock Washer	2
6	1CS1P19	Auger	1	14	1CS1P23	5/16"-18 x 3/8" Set Screw	1
7	1CS1P22	Cord Restraint	1	15	1CS1P18	10" Steel Spinner	1
8	1CS1P29	3/16" Aluminum Rivet	6	16	1CS1P51	Motor Drive Coupler	1

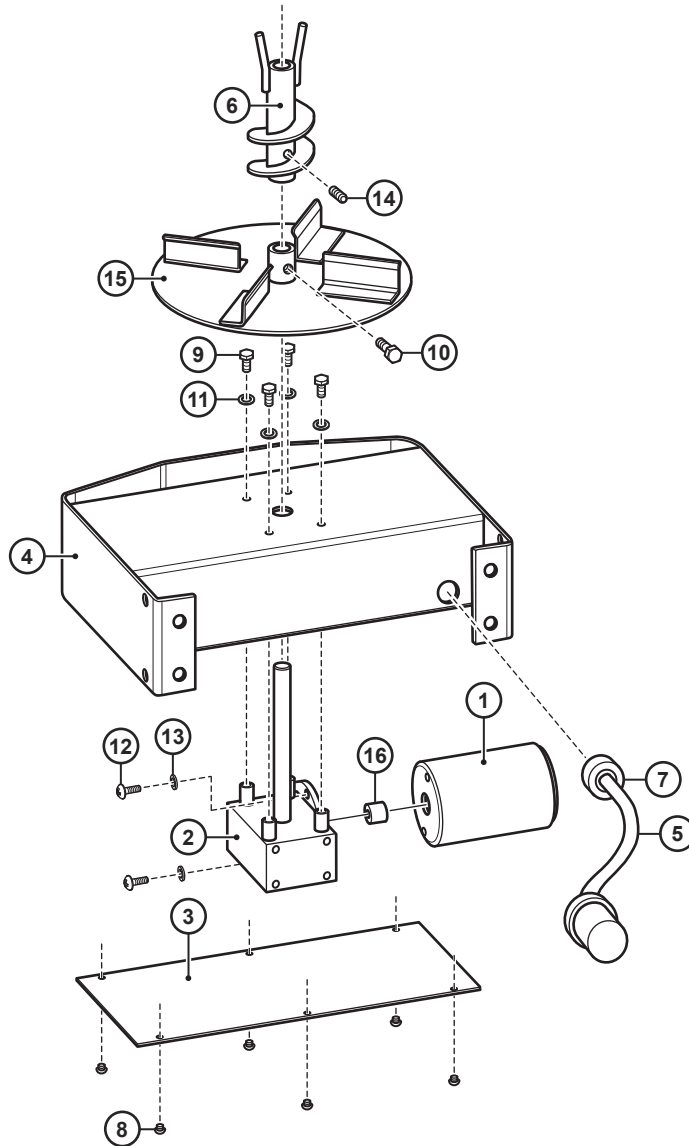

# Sno-Pro Fast-Cast Series Spreaders

## 1CS9 Fast-Cast 300 - Illustrated Parts List

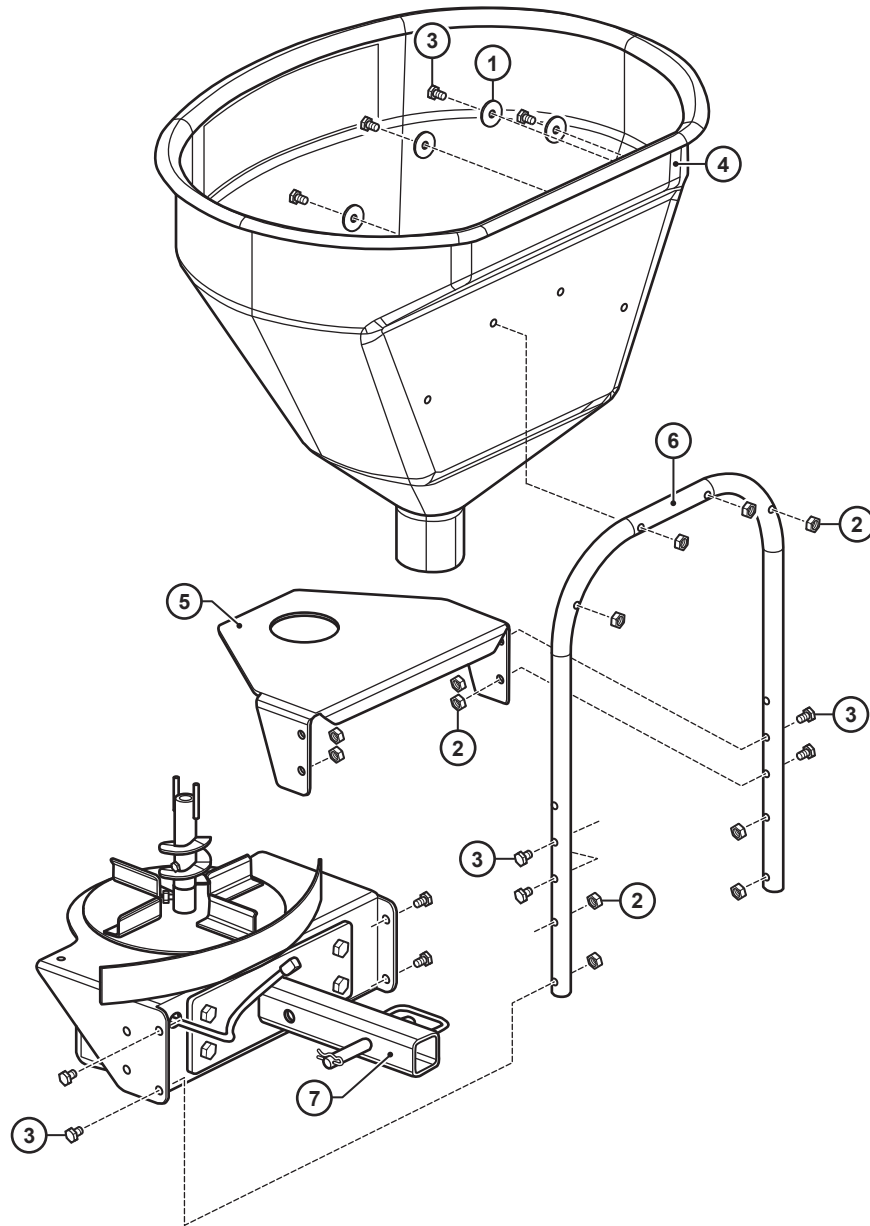

Item No.	Part No.	Description	Qty.
1	1CS2P15	3/8" Fender Washer	4
2	1SM5P1	5/16"-18 Lock Nut	12
3	D6462	5/16"-18 x 1-3/4" HHCS	12
4	1CS9P1	Fast-Cast 300 Salt Hopper	1
5	1CS9P2	Salter Throat Deck	1
6	1CS9P3	Hopper Tube Support	1
7	D6485	Light Duty Receiver Mount	1

# Sno-Pro Fast-Cast Series Spreaders

## 1CS9 Fast-Cast 300 Complete Drive Assembly - Illustrated Parts List

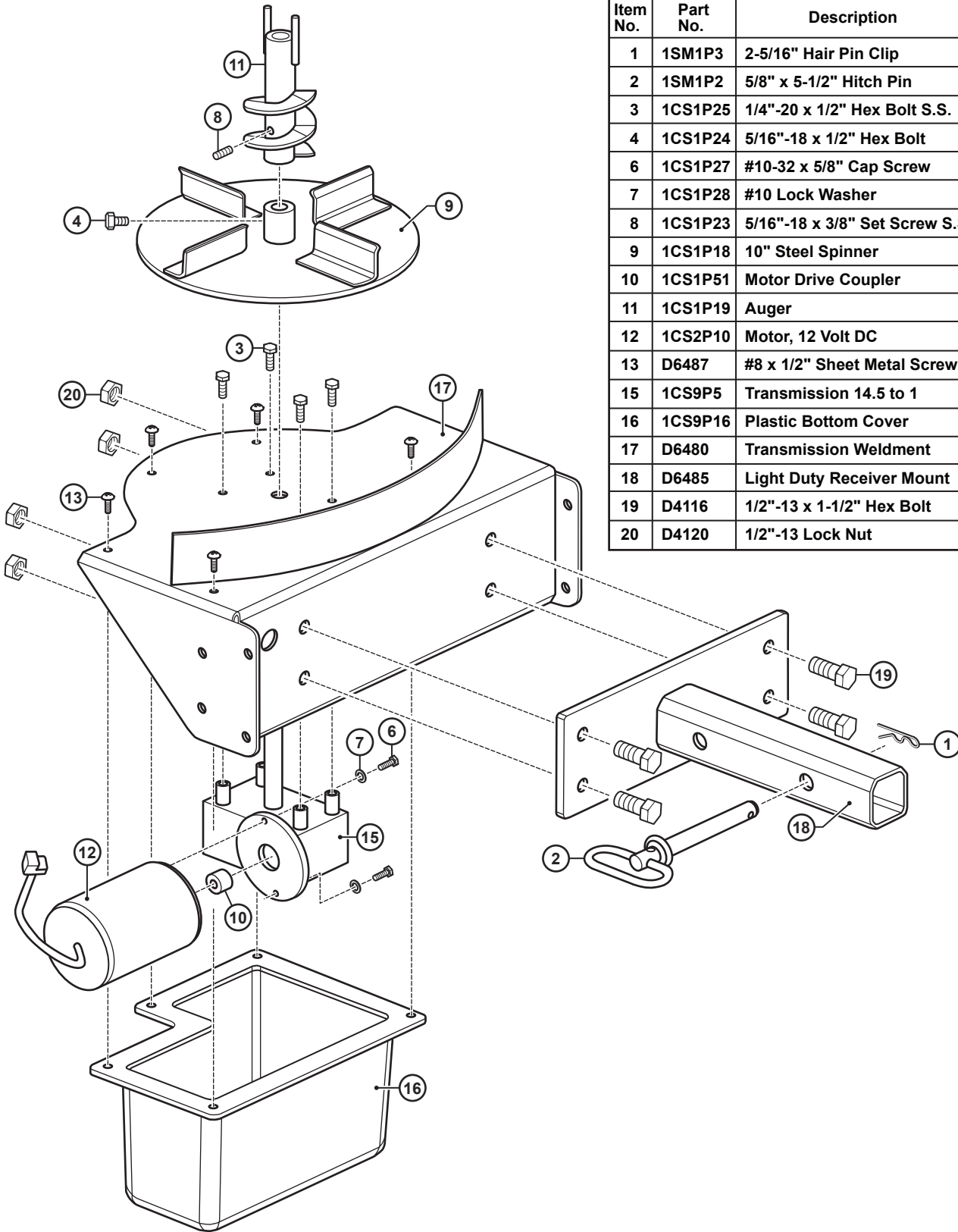

Item No.	Part No.	Description	Qty.
1	1SM1P3	2-5/16" Hair Pin Clip	1
2	1SM1P2	5/8" x 5-1/2" Hitch Pin	1
3	1CS1P25	1/4"-20 x 1/2" Hex Bolt S.S.	4
4	1CS1P24	5/16"-18 x 1/2" Hex Bolt	1
6	1CS1P27	#10-32 x 5/8" Cap Screw	2
7	1CS1P28	#10 Lock Washer	2
8	1CS1P23	5/16"-18 x 3/8" Set Screw S.S.	1
9	1CS1P18	10" Steel Spinner	1
10	1CS1P51	Motor Drive Coupler	1
11	1CS1P19	Auger	1
12	1CS2P10	Motor, 12 Volt DC	1
13	D6487	#8 x 1/2" Sheet Metal Screw	5
15	1CS9P5	Transmission 14.5 to 1	1
16	1CS9P16	Plastic Bottom Cover	1
17	D6480	Transmission Weldment	1
18	D6485	Light Duty Receiver Mount	1
19	D4116	1/2"-13 x 1-1/2" Hex Bolt	4
20	D4120	1/2"-13 Lock Nut	4

# Sno-Pro Fast-Cast Series Spreaders

## 1CS10 Fast-Cast 400 Spreader - Illustrated Parts List

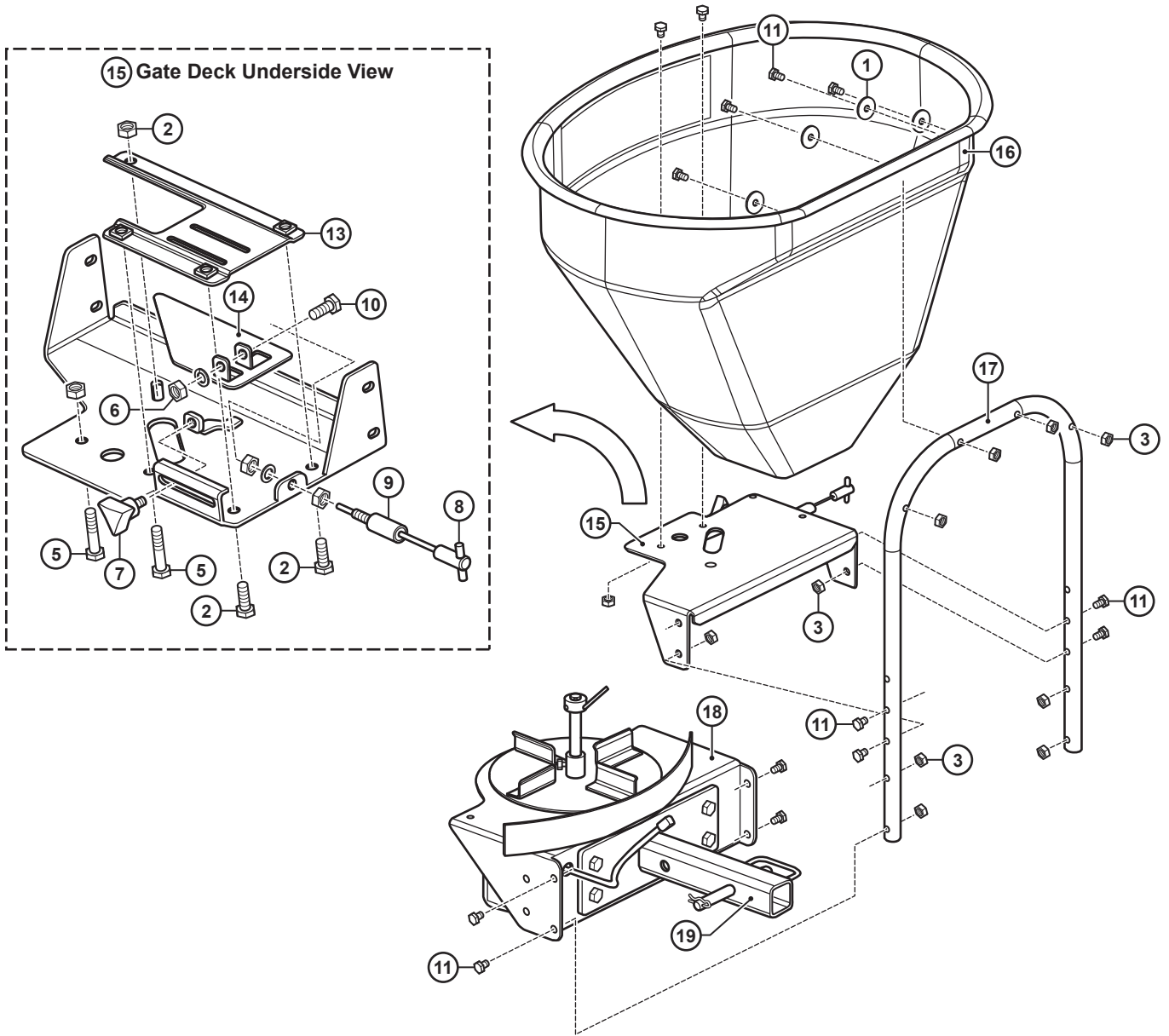

Item No.	Part No.	Description	Qty.
1	1CS2P15	3/8" Fender Washer	4
2	1CS1P24	5/16"-18 x 1/2" Hex Bolt	2
3	1SM5P1	5/16"-18 Lock Nut	14
4	1CS1P46	5/16" Lock Washer	1
5	-	5/16"-18 x 1" Hex Bolt	2
6	1CS1P7	5/16"-18 x 1" Hex Nut	1
7	1CS10P6	Gate Knob	1
8	1GC1A	T-Handle Cable - 20'	1
9	1CS2P16	Bulkhead Cable Fitting	1
10	1CS2P17	5/16"-18 x 3/4" Bolt w/hole	1

Item No.	Part No.	Description	Qty.
11	D6462	5/16"-18 x 1-3/4" HHCS	12
12	1CS10P5	Gate Indicator / Stop	1
13	1CS10P4	Fast-Cast 400 Gate Track	1
14	1CS10P3	Fast-Cast 400 Gate Slide	1
15	1CS10P2	Fast-Cast 400 Gate Deck	1
16	1CS10P1	Fast-Cast 400 Hopper	1
17	1CS9P3	Hopper Tube Support	1
18	D6480	Transmission Weldment	1
19	D6485	Light Duty Receiver Mount	1
20	D4116	1/2"-13 x 1-1/2" Hex Bolt	4
21	D4120	1/2"-13 Lock Nut	4

# Sno-Pro Fast-Cast Series Spreaders

## 1CS10 Fast-Cast 400 Complete Drive Assembly - Illustrated Parts List

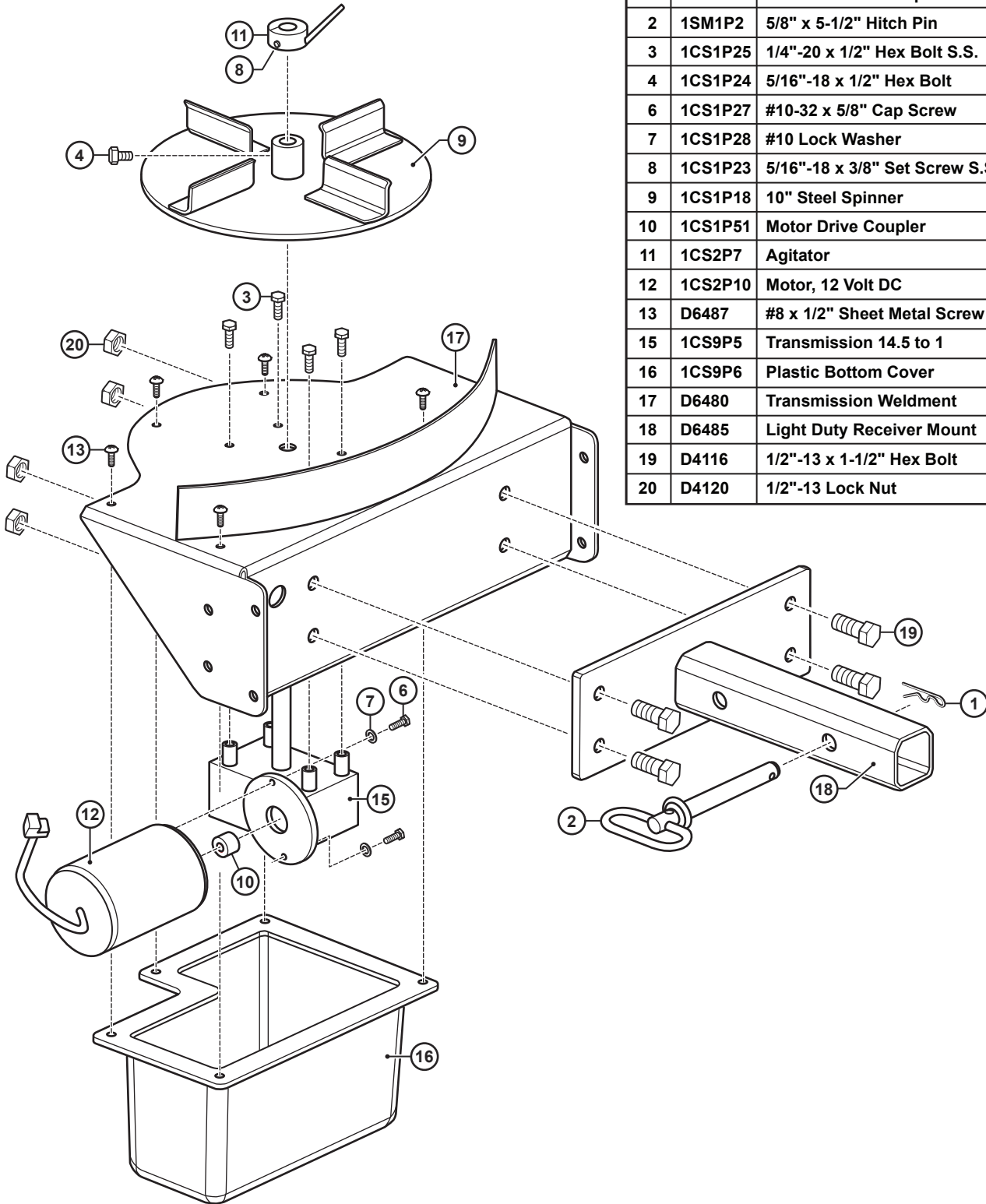

Item No.	Part No.	Description	Qty.
1	1SM1P3	2-5/16" Hair Pin Clip	1
2	1SM1P2	5/8" x 5-1/2" Hitch Pin	1
3	1CS1P25	1/4"-20 x 1/2" Hex Bolt S.S.	4
4	1CS1P24	5/16"-18 x 1/2" Hex Bolt	1
6	1CS1P27	#10-32 x 5/8" Cap Screw	2
7	1CS1P28	#10 Lock Washer	2
8	1CS1P23	5/16"-18 x 3/8" Set Screw S.S.	1
9	1CS1P18	10" Steel Spinner	1
10	1CS1P51	Motor Drive Coupler	1
11	1CS2P7	Agitator	1
12	1CS2P10	Motor, 12 Volt DC	1
13	D6487	#8 x 1/2" Sheet Metal Screw	5
15	1CS9P5	Transmission 14.5 to 1	1
16	1CS9P6	Plastic Bottom Cover	1
17	D6480	Transmission Weldment	1
18	D6485	Light Duty Receiver Mount	1
19	D4116	1/2"-13 x 1-1/2" Hex Bolt	4
20	D4120	1/2"-13 Lock Nut	4

# Sno-Pro Fast-Cast Series Spreaders

## 1SM4 Drop Utility Hitch for Fast-Cast 300 and 400 - Illustrated Parts List

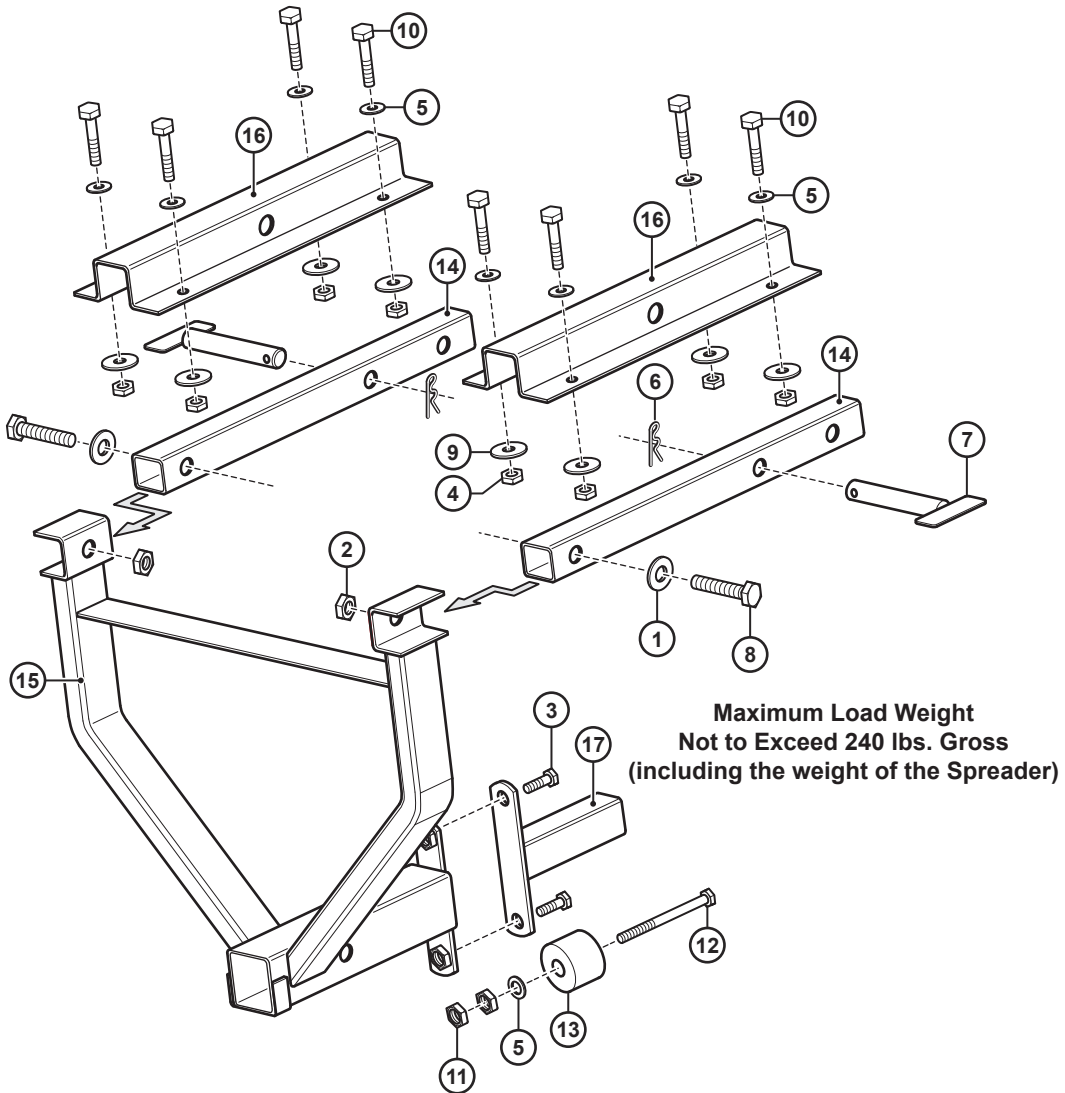

Item No.	Part No.	Description	Qty.
1	1SM3P4	1/2" Flat Washer	2
2	1CS1P11	1/2"-13 Lock Nut	2
3	1CS1P8	3/8"-16 x 1" Hex Bolt	2
4	1CS1P9	3/8"-16 Lock Nut	8
5	1CS1P41	3/8" Flat Washer	9
6	1SM1P3	2-5/16" Hair Pin Clip	2
7	1SM1P2	5/8" x 5-1/2" Hitch Pin	2
8	1SM4P10	1/2"-13 x 2" Hex Bolt	2

Item No.	Part No.	Description	Qty.
9	1CS2P15	3/8" Fender Washer	8
10	1SM4P2	3/8"-16 x 2" Truss Bolt	8
11	1SM4P3	3/8"-16 Hex Nut	2
12	1SM4P4	3/8"-16 x 5" Hex Bolt	1
13	1SM4P5	2" Rubber Stopper	1
14	1SM4P9	Mounting Rail	2
15	1SM4P6	Drop Mount Weldment	1
16	1SM4P7	Mounting Rail Hat Section	2
17	1SM4P8	Mule Adapter	1

## Sno-Pro Fast-Cast Series Spreaders

### 1SM3 3-Point Tractor Mount - Illustrated Parts List

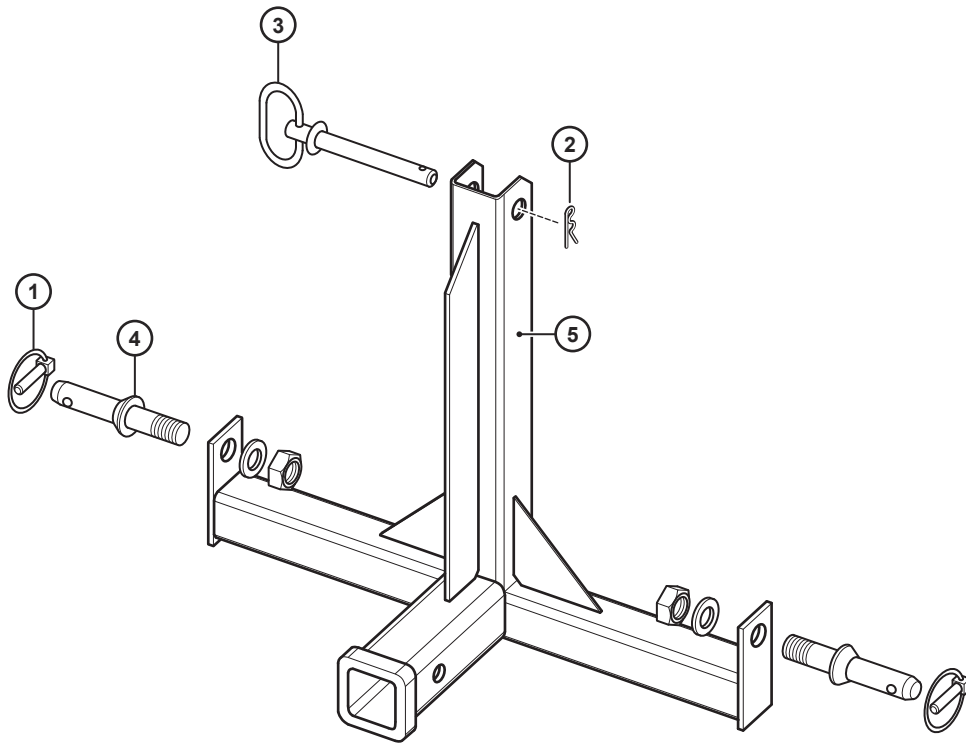

Item No.	Part No.	Description	Qty.
1	1SM1P7	5/16" Linch Pin	2
2	1SM1P3	2-5/16" Hairpin Clip	1
3	1SM1P2	5/8" x 5-1/2" Hitch Pin	1
4	1SM1P6	7/8" x 5-1/2" Lift Arm Pin	2
5	1SM1P1	3-Point Frame	1

# Sno-Pro Fast-Cast Series Spreaders

## Fast-Cast Spreader Optional Accessories

**1AD1 - Adjustable Deflector (Controls Spread Pattern)**

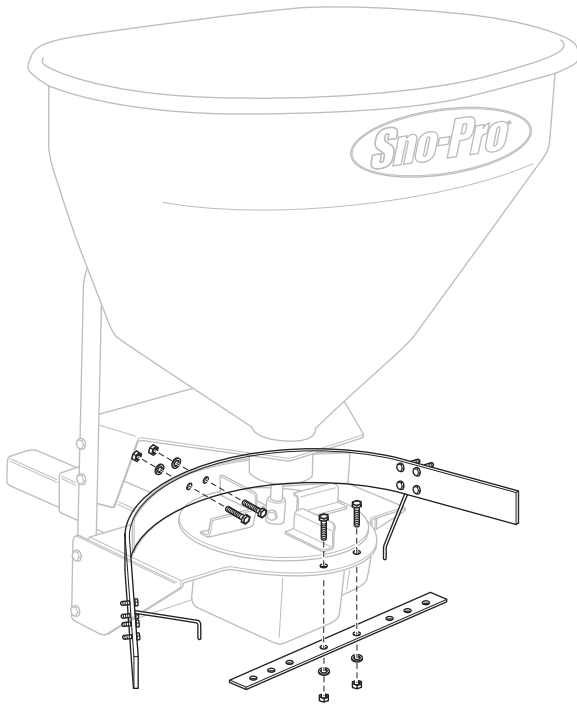

**1GC1 - Gate Flow Control Kit for Fast-Cast 2000**

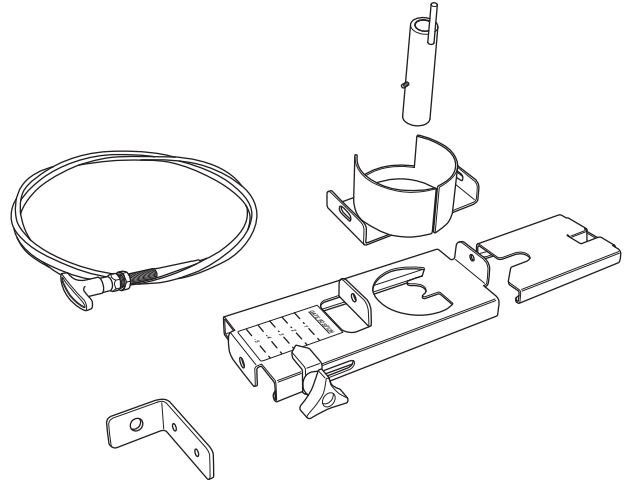

**1SC3 - Variable Speed Control for Fast-Cast 300 or 400**

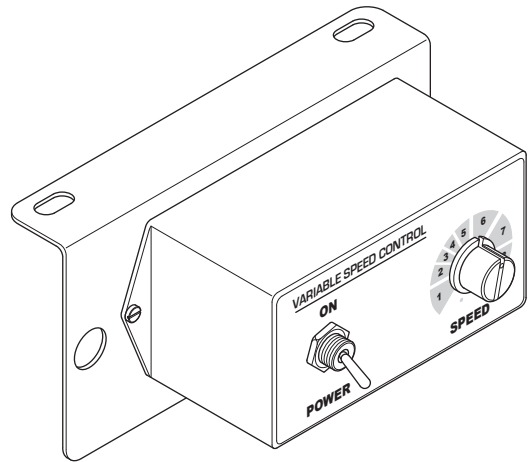

**1WC3 - Weather Cover for Fast-Cast 300 or 400**



**1SM2 - 2" Light Duty Receiver Mount  
(Required for all Fast-Cast 2000 Installations)**

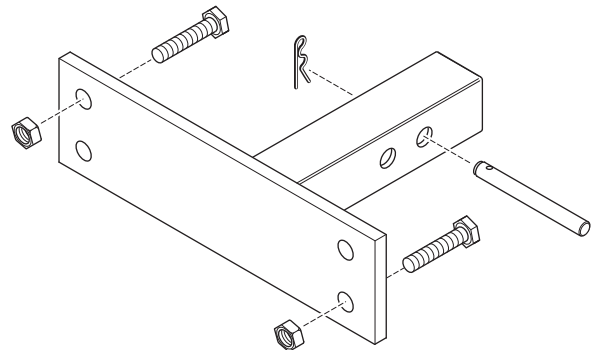

# Sno-Pro Fast-Cast Series Spreaders

## Wiring Harness for Fast-Cast 300 and 400 Spreaders - Illustrated Parts List

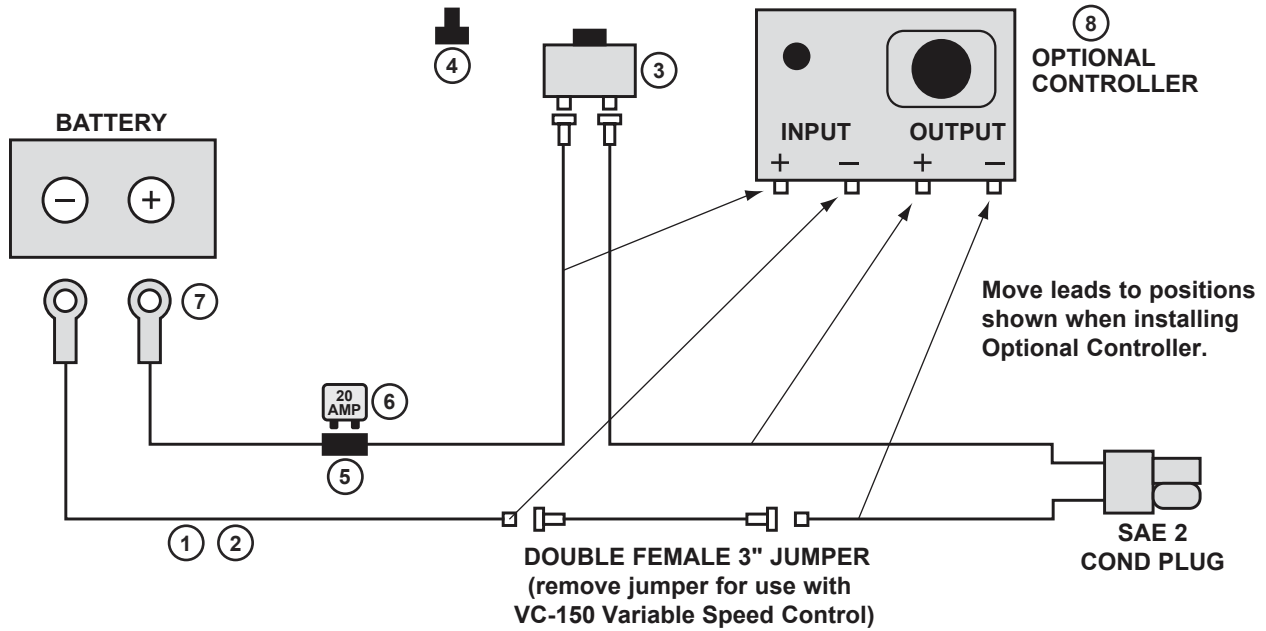

Item No.	Part No.	Description	Qty.
1	1CS2P27	Wiring Harness for Fast-Cast 300	1
2	1CS2P27	Wiring Harness for Fast-Cast 400	1
3	1CS2P25	On / Off Switch	1
4	1CS2P29	Rubber Switch Boot	1

Item No.	Part No.	Description	Qty.
5	1CS2P33	Fuse Holder	1
6	1CS9P7	20 Amp Mini-Fuse	1
7	1CS2P34	3/8" Ring Terminal	2
8	1SC3	Optional Variable Speed Controller	1

### Notes:



From all of us at Curtis, Thank You for choosing our products!