





PARTS & INSTALLATION INSTRUCTIONS E-Z MOUNT XPRESS™ MOUNTING 17146 1999 & Later Chevrolet/GMC K2500-K3500



End user must be given this instruction sheet prior to delivery of this Snow Plow.

SAFETY DEFINITIONS



| | |
|-----------------------------------------------------------------------------------|------------------------------------------------------------------------------------------------------------------------------------------------------------------------------------|
|  | This is the safety alert symbol. It is used to alert you to potential personal injury hazards. Obey all safety messages that follow this symbol to avoid possible injury or death. |
|  | DANGER Indicates an imminently hazardous situation which, if not avoided, will result in death or serious injury. |
|  | WARNING Indicates a potentially hazardous situation which, if not avoided, could result in death or serious injury. |
|  | CAUTION Indicates an potentially hazardous situation which, if not avoided, may result in minor or moderate injury. |
|  | CAUTION used without the safety alert symbol indicates a potentially hazardous situation which, if not avoided, will result in property damage. |

IMPORTANT NOTICE

In conjunction with FMVSS (Federal Motor Vehicle Safety Standards) and OEM (Original Equipment Manufacturer) guidelines, Meyer Products has designed this plow package with the following guidelines:

| | |
|-------------------------------------------------------------------------------------|-------------------------------------------------------------------------------------------------------------------------------------------------------------------------------------------------------------------------------------------------------------------------------------------------------------------------------------------------------------------------------------------------------------------------------------------------------------------------------------------------------------------------------------------------|
|  | Installation of a snowplow may effect your new vehicle warranty. For more information consult your Vehicle Owner's Manual / Vehicle Dealer. |
|  | The vehicle must not be operated when overloaded. In all cases, the loaded vehicle weight, including the entire snowplow system, all aftermarket accessories, driver, passenger, options, nominal fluid levels, and cargo must not exceed the front/rear Gross Axle Weight Rating (GAWR), and total Gross Vehicle Weight Rating (GVWR). These weights ratings are specified on the safety compliance certification label on the driver's side door opening. The use of rear ballast weight may be required to prevent exceeding the front GAWR. |

According to the NHTSA (National Highway Traffic Safety Administration) new and untitled vehicles need to be verified by the installer that snowplow and ballast (if needed) do no exceed the front/rear GAWR and total GVWR.

| | | |
|-------------------------------------------------------------------------------------|-------------------------------------------------------------------------------------|----------------------------------------------------------------------------------------------------------------------|
|  |  | Read the Meyer Owner's Manual before operating or servicing a snowplow. FOLLOW THESE INSTRUCTIONS EXPLICITLY. |
|-------------------------------------------------------------------------------------|-------------------------------------------------------------------------------------|----------------------------------------------------------------------------------------------------------------------|

GENERAL INFORMATION

| | |
|-------------------------------------------------------------------------------------|---------------------------------------------------------------------------------------------------------------------------------------------------------------------------------------------------------------|
|  | SAFETY PRECAUTIONS should be used when Hydraulic Unit is in OPERATION and plow is in a RAISED position. Lower plow to ground when vehicle is PARKED in case of hydraulic failure. |
|-------------------------------------------------------------------------------------|---------------------------------------------------------------------------------------------------------------------------------------------------------------------------------------------------------------|

Check contents against the parts list to determine all are correct and included, and also to familiarize yourself with them.

| | |
|-------------------------------------------------------------------------------------|------------------------------------------------------------------------------------------------------------------------|
|  | Warranty does not apply to a Meyer or Diamond product which has been negligently or improperly assembled or installed. |
|-------------------------------------------------------------------------------------|------------------------------------------------------------------------------------------------------------------------|

OVERHAUL and **SERVICE INFORMATION** are covered on separate instructions.

Meyer Products LLC reserves the right, under its continuing product improvement program, to change construction or design details, specifications and prices without notice or without incurring any obligation.

Meyer Products LLC
18513 Euclid Ave. • Cleveland, Ohio 44112-1084
Phone 486-1313 (Area Code 216)
www.meyerproducts.com • email info@meyerproducts.com



Meyer Products LLC
6 Angell Lane • Damariscotta, ME 04543-4507
Phone 563-2227 (Area Code 207)
www.meyerproducts.com • email info@meyerproducts.com

Parts List

| Item | Part No. | Qty | Description |
|------|----------|-----|------------------------------------------|
| 1 | 17146 | 1 | E-Z Mount Xpress™ Mounting Carton |
| 2 | 19339 | 1 | • L.H. Weldment |
| 3 | 19340 | 1 | • R.H. Weldment |
| 4 | 22482 | 2 | • Handle Bolt |
| | 08827 | 1 | • Hardware Bag |
| 5 | 22182 | 4 | • Bolt H M12 x 1.75 a 40 MM Gr. 10.9 |
| 6 | 22497 | 4 | • Bolt H 3/4-10 x 2-1/4" Gr. 5 Custom |
| 7 | 14595 | 2 | • 3/4: J-Bolt |
| 8 | 20310 | 8 | • Locknut Esna 3/4-10 |
| 9 | 20355 | 4 | • Flatwasher 1/2" |
| | 21260 | 2 | • Flatwasher 3/4" SAE |
| | 21976 | 2 | • Battery Connector |
| 10 | 08406 | 1 | • 2007 Harware Bag |
| 11 | 20096 | 2 | ••• 1/2-13 x 1-3/4" Gr.5 |
| 12 | 19758 | 2 | ••• 1/2-13 Handle Nut |
| | 20355 | 2 | ••• Flatwasher 1/2" |
| 13 | 19170 | 1 | Brush Guard Lift Frame |
| 14 | 07292 | 2 | Rubber Bumper |
| • | 16535 | 1 | Pivot Bar/A-Frame Carton |

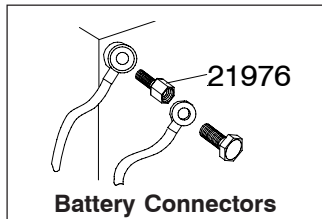

General Information (Continued)

CAUTION

CAUTION: To avoid harm to vehicles electrical system always disconnect battery before beginning installation.

DO NOT BURN holes or **WELD** vehicle frame. This may cause frame failure.

After first use, retighten all mounting bolt connections to specified torque. All mounting bolt connections to be checked periodically for tightness.

Locknuts are furnished **DO NOT** tighten bolts and nuts until installation is complete (unless otherwise specified), then be sure to tighten all attaching parts per specified torque chart.

TORQUE CHART FOOT

| Bolt Nut Size | Gr. 2 | Gr. 5 | Gr. 8 |
|---------------|---------|-----------|-----------|
| 1/4 - 20 | 4 - 5 | | |
| 5/16 - 18 | 9 - 11 | | |
| 3/8 - 16 | 17 - 20 | 26 - 29 | |
| 7/16 - 14 | | 42 - 46 | 60 - 66 |
| 1/2 - 13 | | 64 - 72 | 90 - 100 |
| 5/8 - 11 | | 127 - 141 | 179 - 198 |

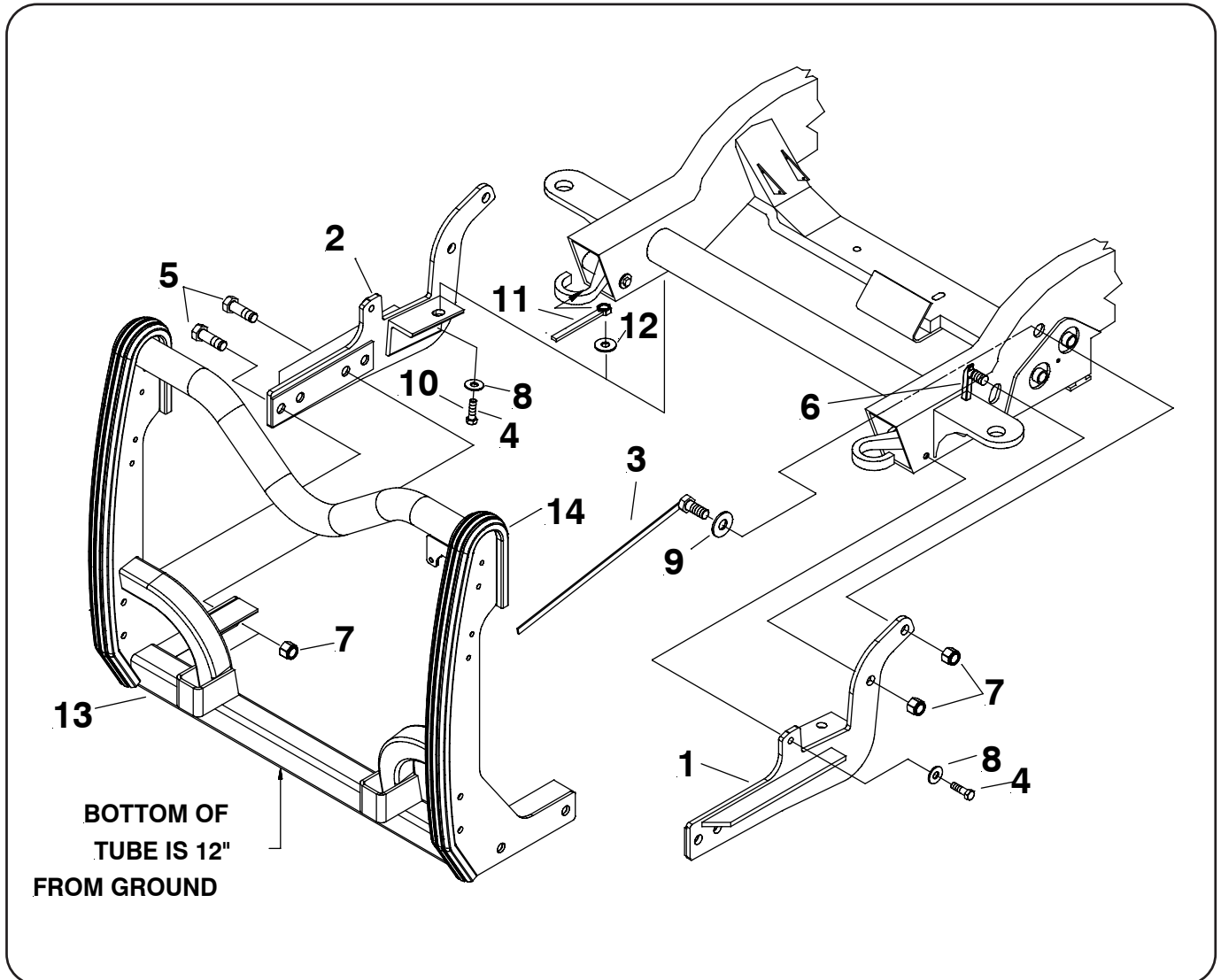

VEHICLE RECOMMENDATIONS

General Motors Corp.

General Motors recommends snowplow usage for only those trucks that have the option "VYU" Snow Plow Preparation Package.

General Motors recommends that when a snow plow is mounted that only one passenger should accompany the driver. More than one passenger may exceed front gross axle weight ratings.

Model G.V.W. Opt.Code Fr. G.V.W.R.

Regular/Extended Cab

| | | | | |
|---------|--------|----------|-------|----------|
| 1999-00 | C 2500 | 7200 lb. | (C5Z) | 4100 lb. |
| 1999-00 | C 2500 | 8600 lb. | (C6P) | 4100 lb. |
| 1999-00 | K 2500 | 8600 lb. | (C6P) | 4500 lb. |
| 2002-04 | K 2500 | 8600 lb. | (C6P) | 4500 lb. |

Regular/Extended/Crew Cab

| | | | | |
|---------|-------|-----------|-------|----------|
| 2001-04 | K2500 | 9200 lb. | (C6W) | 4800 lb. |
| 2001-04 | K3500 | 11400 lb. | (C7W) | 4800 lb. |
| 2004-04 | K3500 | 9900 lb. | (C4M) | 4800 lb. |

Cab Chassis Regular Cab Only

| | | | | |
|---------|--------|----------|-------|----------|
| 1999-00 | C 2500 | 8600 lb. | (C6P) | 4100 lb. |
| 1999-00 | K 2500 | 8600 lb. | (C6P) | 4500 lb. |

Cab Chassis Regular/Extended Cab

| | | | | |
|---------|-------|-----------|-------|----------|
| 2001-04 | K3500 | 12000 lb. | (C7L) | 4800 lb. |
|---------|-------|-----------|-------|----------|



Sport Utility Vehicles: Suburban/Yukon XL/Avalanche

| | | | | |
|---------|-------|------|-------|----------|
| 2001 | K2500 | 8600 | (CP6) | 4500 lb. |
| 2002-04 | K2500 | 8600 | (CP6) | 4100 lb. |
| 2002-04 | K2500 | 8600 | (CP6) | 4380 lb. |

Rear ballast may be necessary depending on the size plow installed. Rear ballast is determined by weighing a vehicle's front and rear axles and adding weight behind the rear axle until front axle weight is under or equal to the vehicle specific front GAWR while not exceeding the rear GAWR and GVWR.

Vehicle option packages may vary. If in doubt, it is always a good idea to weigh the vehicle to ensure all weight ratings are not exceeded with plow in the raised position.

TORQUE CHART FOOT

| Bolt Nut Size | Gr. 2  | Gr. 5  | Gr. 8  |
|---------------|-------------------------------------------------------------------------------------------|-------------------------------------------------------------------------------------------|-------------------------------------------------------------------------------------------|
| 1/4 - 20 | 4 - 5 | | |
| 5/16 - 18 | 9 - 11 | | |
| 3/8 - 16 | 17 - 20 | 26 - 29 | |
| 7/16 - 14 | | 42 - 46 | 60 - 66 |
| 1/2 - 13 | | 64 - 72 | 90 - 100 |
| 5/8 - 11 | | 127 - 141 | 179 - 198 |

INSTALLATION INSTRUCTIONS

INSTALLATION INSTRUCTIONS

- A. 1999-2002 Model Trucks / All Year SUV's (Except 2004 Avalanche): The air dam is taller and comes closer to the ground than 2003 & later. The mounting may be installed with air dam on/off or notched out around the LH & RH Weldments (1&2). **Note:** The air dam may need to be significantly deformed up if notching out is not desired.

2003 & Later Model Trucks / 2004 & Later Avalanche: The mount will install under the air dam with minimal deformation.

- B. Remove tow hook bolts from the bottom flange and outside of the frame rail on both driver and passenger sides. Retain hardware. They will not be reused. **On 2007 & Later models remove tow hooks and hardware entirely.**
- C. Install 3/4 J-Bolt (6) into vehicle frame slot behind the radiator bracket as shown on each side. Be careful to not let them fall into the frame.
- D. Position LH & RH Weldments (1&2) on the outside of frame rails and loosely install the second highest hole using the 3/4 J-Bolt (6) and 3/4-10 Locknut (7) on each side. **Snug all bolts during the installation. Do not torque any bolts until final step.**
- E. Install 3/4 Flatwasher (9) to Handle Bolt (3). Install handle bolt and washer assembly inside the frame by going over the towhook and protrude out the existing frame and rear mount hole on each side. Attach using a 3/4-10 Locknut (7) on each side.
- F. Attach LH & RH Weldments (1&2) to towhooks in front and bottom side holes by replacing bolts in step B with M12 x 1.75 x 40 mm bolts (4), and 1/2" washers (8). **On 2007 & Later models use 1/2-13 x 1-3/4 Bolt (10), 1/2 Flatwashers (8 & 12) and 1/2-13 Handle Nut (11) on bottom side holes.**
- G. 1999-2002 Model Trucks / All Year SUV's (Except 2004 Avalanche): Attach Brush Guard/Lift Frame (13) to LH & RH Weldment's (1&2) 2nd and 4th holes from the front using two 3/4-10 x 2 1/4 bolts (5) and 3/4-10 locknuts (7) on each side.
- 2003 & Later Model Trucks / 2004 & Later Avalanche: Attach Brush Guard/Lift Frame (13) to LH & RH Weldment's (1&2) 1st and 3rd holes from the front using two 3/4-10 x 2 1/4 bolts (5) and 3/4-10 locknuts (7) on each side.
- H. Tighten all fasteners to their proper torque. Tighten all towhook bolts first. Then tighten in the same order they were assembled to the vehicle.
- I. Install remaining snowplow hardware per separate instructions.

Meyer Products Inc. or Diamond Equipment assumes no responsibility for installations not made in accordance with these instructions.