



WESTERN PRODUCTS
7777 NORTH 73RD STREET
P.O. BOX 23045
MILWAUKEE, WISCONSIN 53223

UniMount

DD A DIVISION OF DOUGLAS DYNAMICS, INC.

Vehicle Installation Instructions and
Parts List

Model 1545
Mount Assembly Box No. 61440
Chev/GMC Light Truck 1988 - 1994
Hydraulics Box No. 56365
Harness Kit No. 61545 or 61515 or 61580
November 18, 1994

MINIMUM VEHICLE RECOMMENDATIONS
HD Alternator
HD Battery
HD Torsion Bars
Mfg. Snowplow Prep Package
REAR BALLAST - 500 lbs. when plow is attached
SECURE WEIGHT BEHIND REAR WHEELS.

DO NOT use this mount on 1995 vehicles with supplemental restraining system (SRS) commonly known as airbags. Vehicles with GVWR over 8,500 LBS. do not have SRS (airbags).

Mount Assembly Box No. 61440
PARTS DIAGRAM & LIST

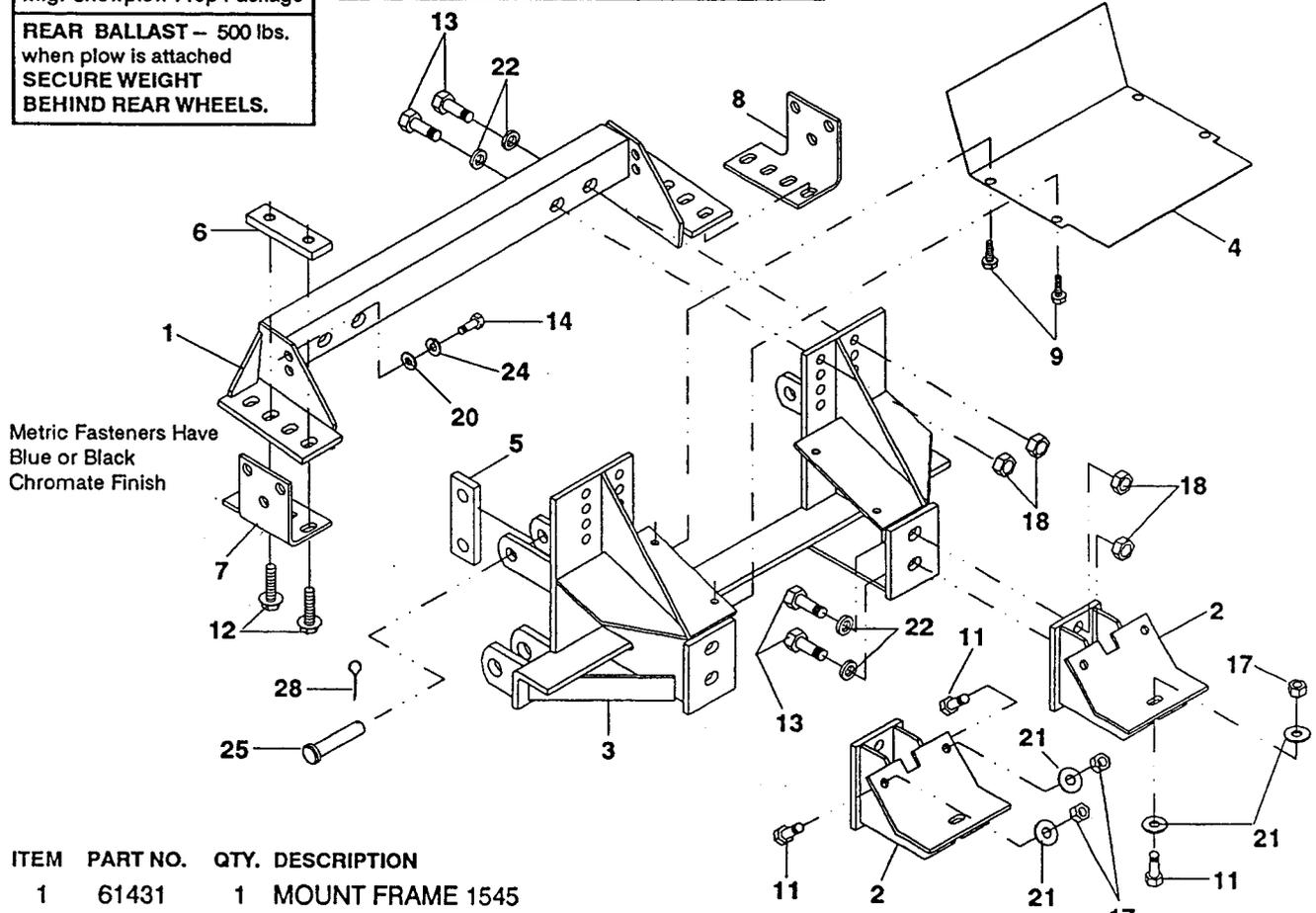

Metric Fasteners Have Blue or Black Chromate Finish

ITEM	PART NO.	QTY.	DESCRIPTION
1	61431	1	MOUNT FRAME 1545
2	61365	2	THRUST ARM
3	61374	1	SPREADER
4	61436	1	SPLASH GUARD
5	61432	2	LINK ARM
6	61433	2	NUT BAR
7	62228	1	FORMED SUPPORT DR
8	62229	1	FORMED SUPPORT CU
9	93169	4	3/8-16X1 HXW TRTS TY SW ZP
11	90100	6	1/2-13X1-1/2 HX CS G5 ZYC
12	90120	4	1/2-13X2 SFLS G5 ZP FULL THD
13	90128	8	5/8-11X1-3/4 HX CS G5 ZP
14	95051	2	M10X1.5X30 HX CS G8.8
17	91335	6	1/2-13 PT HX LK NUT NYIS ZYC
18	91337	8	5/8-11 PT HX LK NUT NYIS ZYC
20	91103	2	3/8 PLAIN WASHER TY A STD ZP
21	91105	8	1/2 PLAIN WASHER TY A STD ZYC
22	91139	8	5/8 PLAIN WASHER TY A SAE ZP
24	95173	2	M10 SP LK WASHER
25	93062	2	RIVET 3/4" X 3-1/4" G5 ZYC
128	91911	2	5/32x1-1/2 COTTER PIN ZYC

ITEM	PART NO.	QTY.	DESCRIPTION
NOT SHOWN			
	55930	1	BATTERY CABLE ADAPTOR
	56080	1	DASH BRACKET
	61539	1	PANEL MOUNT PLATE SET-SHORT
	61536	8	CABLE TIE - LONG
	90308	2	#10-24X3/4 RD MS BZP
	91098	2	#10 PLAIN WASHER TY B NAR ZP
	91401	2	#10-24 HX NUT ZP

Parts listed above may be found in the following assembly
61722 1 BOLT BAG ASSY (61440)

Abbreviations			
ASSY	Assembly	SAE	Society of Automotive Engineers
BZP	Black Zinc Plate	SFLS	Serrated Flange Lock Screw
CS	Capscrew	SP	Spring
G	Grade	STD	Standard
HX	Hex	THD	Thread
HXW	Hex Washer	TY	Type
LK	Lock	TRTS	Thread Rolling
MS	Machine Screw	ZP	Zinc Plate
NAR	Narrow (SAE)	ZYC	Zinc Yellow Chromate
NYIS	Nylon Insert		
PT	Prevailing Torque		
RD	Round Head		

Recommended Fastener Torque Chart (Ft.-Lbs.)					
Size	SAE Grade 2	SAE Grade 5	SAE Grade 8		
1/4-20	6	9	13		
5/16-18	11	18	28		
3/8-16	19	31	48		
3/8-24	24	48	68		
7/16-14	30	50	75		
1/2-13	45	75	115		
9/16-12	68	110	165		
5/8-11	93	150	225		
3/4-10	150	250	370		
7/8-9	202	378	591		
1-8	300	583	893		
Metric Grade 8.8 (Ft.-Lbs.)					
Size	Torque	Size	Torque		
M 6	7	M 12	60		
M 8	17	M 14	95		
M 10	35	M 18	155		

These torque values apply to mount assembly fasteners except those noted in the instruction.

AS VIEWED FROM DRIVER SIDE

IMPORTANT: Read instructions before assembling. Bolts should be finger tight until instructed to tighten according to the Torque Chart. Use standard methods and practices when attaching mount assembly, including wearing safety glasses.

Parts to be installed are furnished in mount box.

MOUNT FRAME

1. Remove air dam, splash shield, tow hooks, and tapped bars from inside of boxed frame rails. Retain all removed parts except tow hooks and replace whenever mount assembly is removed from vehicle.
2. Place mount frame between vehicle frame rails. See diagrams at right.

6 Lug Wheels: align top hole in mount frame with threaded hole in vehicle frame rail.

8 Lug Wheels: align bottom hole in mount frame with threaded hole in vehicle frame rail.

Attach mount frame to vehicle frame with a 10mm x 30mm screw, 10mm lock washer and 3/8" flat washer to vehicle frame on each side.

3. After hanging the mount frame on vehicle, hold or clamp the mount frame tight to the bottom of the vehicle frame.

Ream two tow hook fastener holes in each vehicle frame rail with a 17/32" drill bit.

Revised light duty frame (6 lug wheels) beginning July 1993 and all later models – If the tow hook holes in the bottom of the vehicle frame do not line up with the mount frame slots, use the second and fourth slots from front of mount frame as a template to drill new 17/32" tow hook holes in the bottom of vehicle frame rails.

4. Complete this step and Steps 5 and 6 on one side of the vehicle before starting on the other side (this will keep the bumper in place).

Remove the three bolts securing the bumper bracket to the vehicle's frame rail.

Position three-hole leg of the formed support over the bumper bracket bolt holes (four-slotted leg should align with the mount frame slots and tow hook holes). Loosely reinstall the existing bumper bracket bolts.

5. Place a furnished nut bar inside vehicle frame rail and align with tow hook holes.
6. Align holes in existing tow hooks with formed support slots, mount frame slots, and tow hook holes in vehicle frame. Fasten with two 1/2" x 2" serrated flange head screws into nut bar.

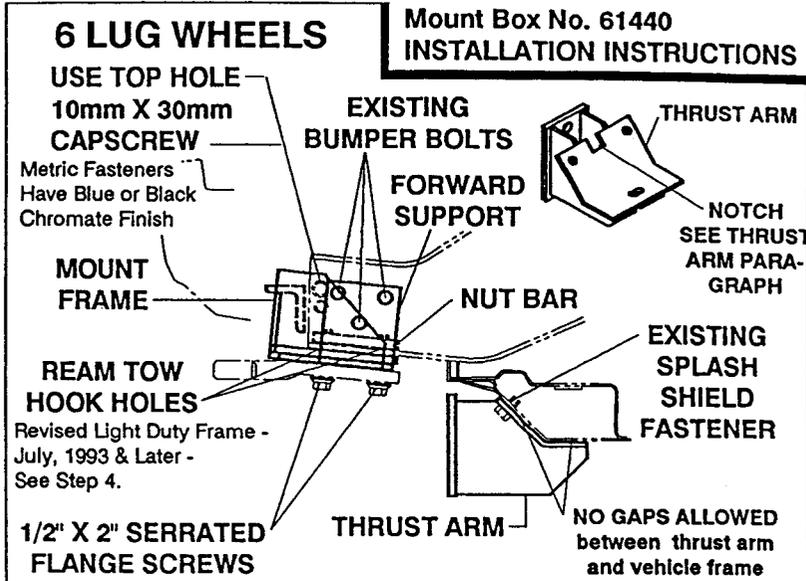

OR

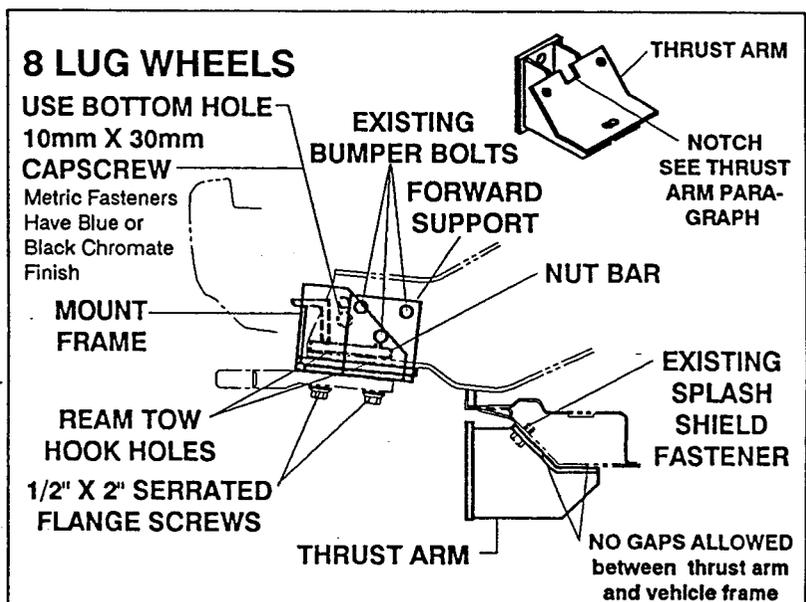

Starting with bumper bracket bolts, metric screws, and then tow hook bolts, tighten fasteners according to the Torque Chart on page 2. Do not overtighten metric fasteners.

7. Repeat steps 4, 5, and 6 on other side of vehicle

THRUST ARM (See diagrams on page 2)

On driver-side of vehicle frame cross member, thread one existing splash shield fastener halfway into cross member. Position a thrust arm against cross member so notch in top of thrust arm (see diagrams on page 2) slides under the head of the splash shield fastener. Slide thrust arm towards center of vehicle and tighten splash shield fastener to hold thrust arm in place. Thrust arm **MUST** fit flat against both surfaces of vehicle cross member.

Repeat on curb-side of cross member for other thrust arm.

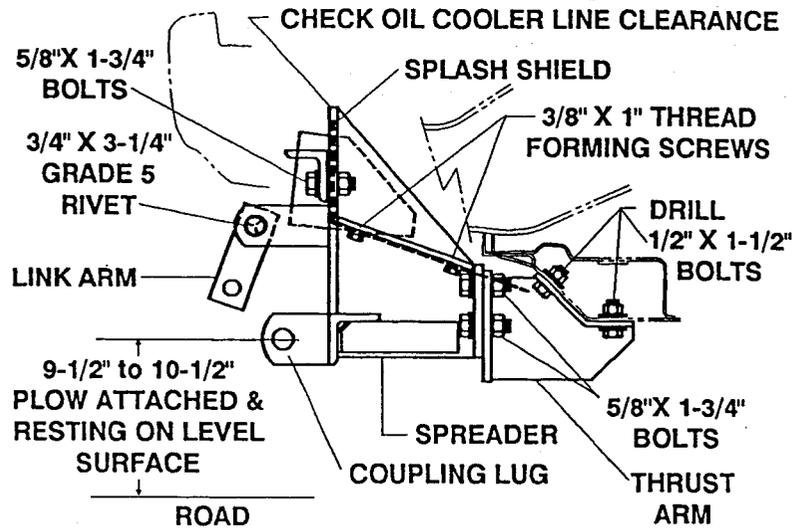

SPREADER

1. Attach spreader to mount frame with two 5/8" x 1-3/4" bolts, SAE flat washers to slots, and locknuts on each side. During installation, allow for drop in vehicle height when weight of plow is added. The distance between the center of the coupling lug hole and the level surface should be 9-1/2" to 10-1/2" with plow attached and resting on the level surface. (See Coupling Lug Height Check near end of these instructions.)

Verify top of spreader is not touching any oil cooler lines. Cut off top of spreader if required.

Attach spreader to thrust arms with two 5/8" x 1-3/4" bolts, SAE flat washers to slots, and locknuts on each side.

2. Use holes in thrust arms as a template to drill three 17/32" holes on each side into vehicle frame cross member. Fasten thrust arms to cross member with three 1/2" x 1-1/2" bolts and flat washers to the cross member, one flat washer to the thrust arm slot, and three locknuts on each side.
3. Starting with 1/2" fasteners, tighten all fasteners according to the Torque Chart on page 2.

SPLASH SHIELD

Install splash shield onto bottom of plates in center of spreader with four 3/8" x 1" thread forming screws. Tighten screws according to the Torque Chart on page 2.

LINK ARMS

1. Attach link arms to upper pairs of spreader lugs using one 3/4" x 3-1/4" grade 5 rivet and cotter pin on each side.
2. After attaching plow, check for 3" of clearance between hood and lift frame.

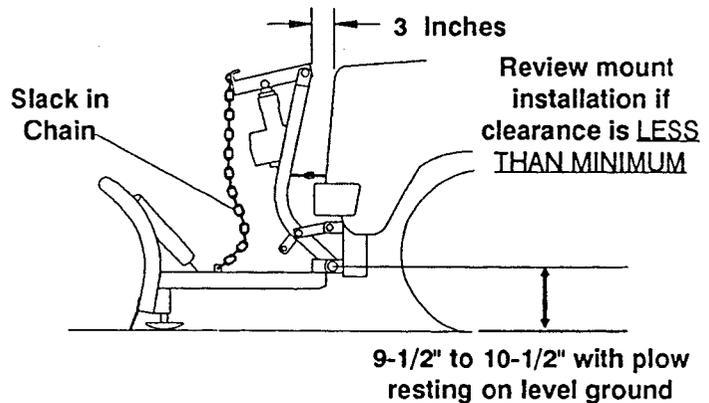

NOTE: After 5 to 10 hours of snowplow usage, retorque all mount assembly fasteners.

Continued on next page.

NOTE: During electrical installation, the long battery ground cable (no stripe) must be grounded to a capscrew on the engine or to the **NEGATIVE** battery terminal.

HARNESS KIT SELECTION (DO NOT change turn signal flasher.)

For **DUAL** Type 2B Headlamps - Use Box No 61540 Headlamp Kit 9-Pin and 61545 Harness Kit 2B/2D 9-Pin -A.

For **QUAD** Type LF & UF - Use Box No 61540 Headlamp Kit 9-Pin and 61580 Harness Kit LF & UF 9-Pin -A.

For **QUAD** Type HB-3 & HB-4 - Use Box No 61540 Headlamp Kit 9-Pin and 61515 Harness Kit HB-3 & HB-4 9-Pin -A.

ENGINE OVERHEATING

In the event vehicle engine overheating occurs while traveling with the plow attached, the **CLUTCH FAN ASSEMBLY** should be checked by a General Motors (GM) Dealer's Service Department according to the Chevrolet Service Bulletin 6B.

SPECIAL INSTRUCTIONS

Chevrolet and GMC
Light Trucks

HAZARD WARNING CIRCUIT

Snowplow park/turn and hazard lights can overload the vehicle electrical circuit when hazard lights flash for extended periods of time or when the foot brake is activated with hazard lights flashing. GM recommends that a light harness and relays be installed for snowplow lighting. See your GM dealer for service bulletin #90-8A-20. Western also offers a Directional Harness Kit, # 61185.

**Solenoid Control
and Dash Bracket
INSTALLATION INSTRUCTIONS**

Parts to be installed are found in the hydraulics box, except for parts indicated in ().

1. Remove the center (air vent) section of the dash located above and to the right of the ash tray. Pry out at the bottom, then press in at the top while pulling down and out at the bottom. Disconnect any electrical equipment attached to the panel. Remove radio if located below center section of dash.
2. Temporarily assemble solenoid control to control bracket using two no. 8 x 5/8" hex head screws and control bracket to dash using four no. 8 x 3/8" hex head thread cutting screws and lock washers.
3. Locate control assembly to the right of the ash tray, and up to the bevel on the flat recessed surface. The bracket should fit fairly flat against the surface of the dash. Verify that the control lever will clear all vehicle components in all positions and for adequate drill clearance (look into opening to locate ribs) before drilling holes.
4. Mark this location.
5. Remove dash bracket from control assembly. Place bracket in the selected location and mark all four mounting holes.
6. Drill 7/32" holes in the dash for the lower two holes, and 1/8" holes in the dash for the upper two holes for aligning holes in the dash bracket. Secure using two no. 10 x 3/4" machine screws, flat washers to dash, and nuts (found in mount box) in the lower holes and no. 10 x 1" sheet metal screws and lock washers in the upper holes.
7. Reassemble control bracket to dash bracket. Bend top flange of control bracket to desired position.
8. Secure harness to control bracket with cable clamp and a no. 8 x 3/8" thread cutting tapping screw.
9. Replace the radio (if removed) and dash panel.

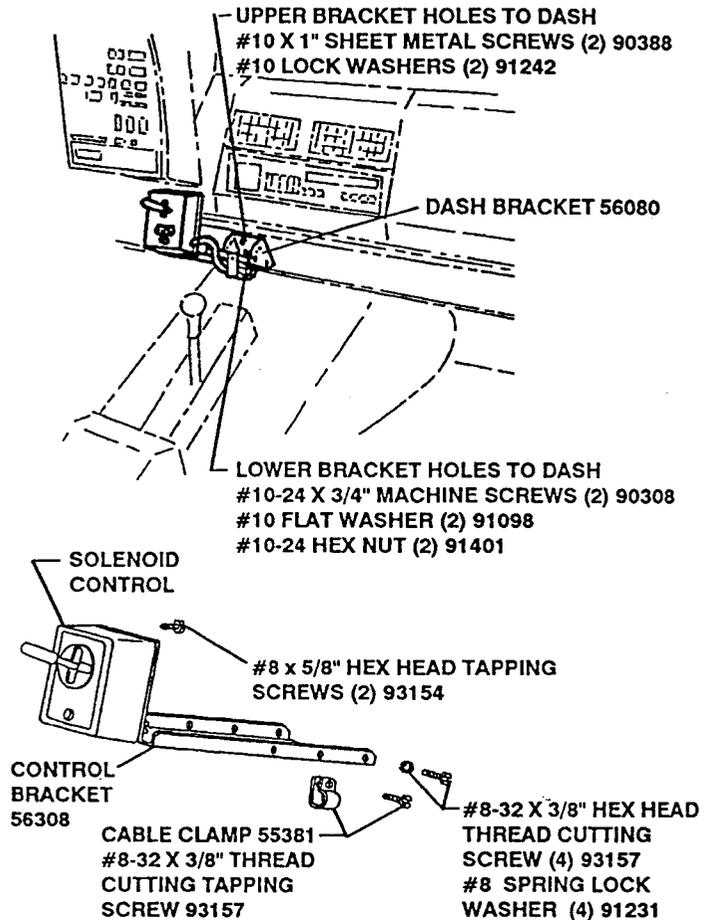



SAFETY NOTE: Whenever you see this symbol, it notes a **SAFETY WARNING**. To avoid serious injury to yourself or others, follow all warnings.

**Vehicle Underhood
INSTALLATION INSTRUCTIONS**

**HARNESS, SOLENOID CONTROL
& MOTOR RELAY
INSTALLATION DIAGRAM**

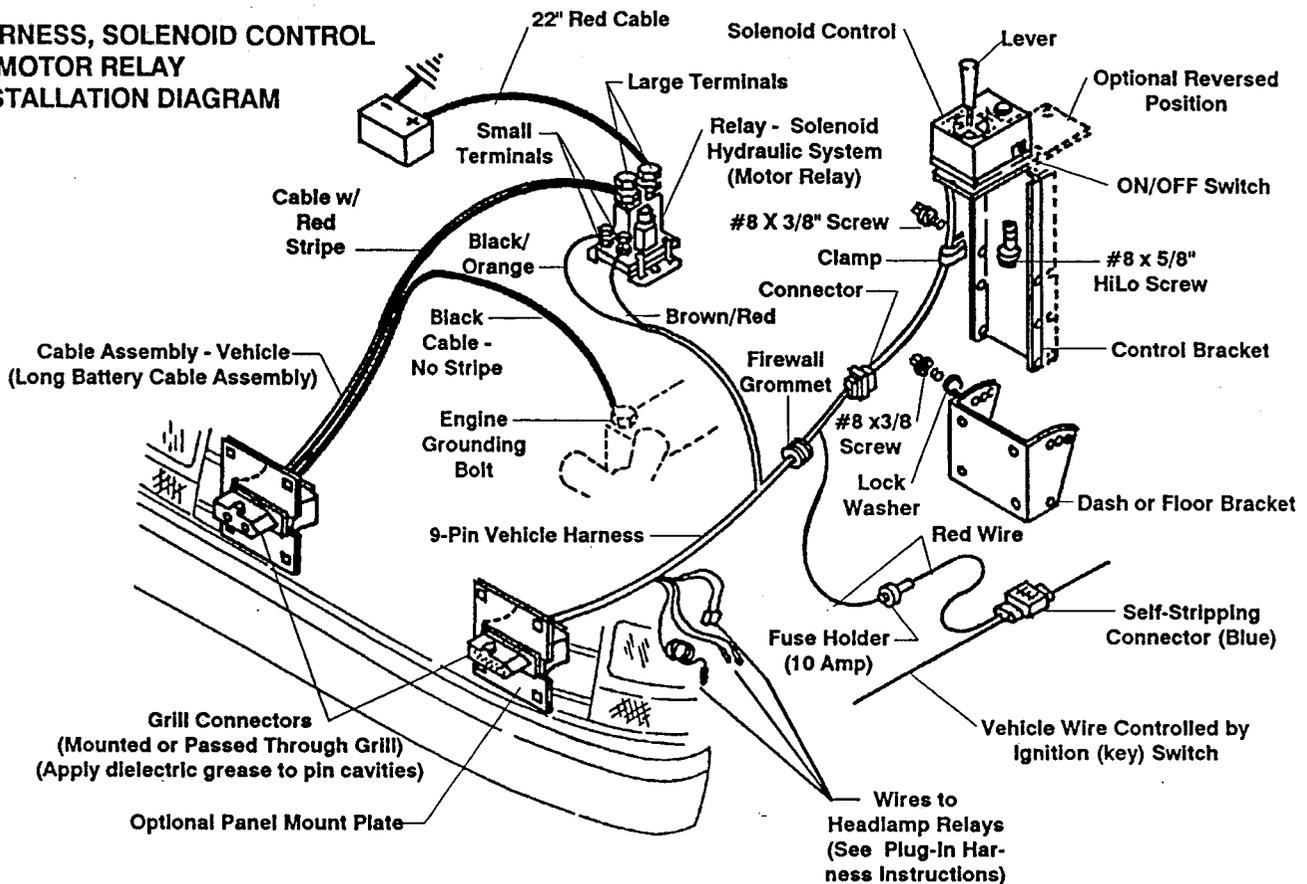

9-Pin Vehicle Harness And Motor Relay

Except as noted, parts to be installed are found in the hydraulics box

CAUTION: To prevent corrosion on all underhood electrical connections, use dielectric grease to fill receptacles and lightly coat ring terminals and blades before assembling, or lightly coat the connections after assembling.

1. Identify wires for the parking lamp and left turn signal on the driver-side of vehicle, and right turn signal on curb-side of vehicle. Attach a black self-stripping bullet receptacle connector (found in harness kit) to each of these three wires.

OPTION on GM vehicles: Identify wires for parking lamps and both turn signals in the main harness behind the driver-side headlamp. Attach a black self-stripping bullet receptacle connector to each of these three wires.

2. Remove **NEGATIVE** battery cable from battery.



WARNING: Electrical shock hazard. Disconnect battery before beginning electrical installation.

3. Find a location for the motor relay where it will be protected from road splash and will be within 18" of the vehicle primary battery. **NOTE:** Motor relay terminals must be vertical or horizontal. Using the motor relay mounting plate as a template, drill two 9/32" holes, and mount motor relay to holes using 1/4" x 3/4" bolts, flat washers, and locknuts.
4. Route 22" red battery cable between a large motor relay terminal and the **POSITIVE** battery terminal taking care to avoid sharp edges and moving parts. Attach cable to motor relay terminal with a lock washer and 5/16"-24 jam nut. Attach cable to battery **POSITIVE** terminal with existing terminal fastener. **NOTE:** Side terminal batteries – use battery cable adaptor (found in mount box).

- Stretch rectangular openings of plug cover straps (found in harness kit) over grill connector ends of long battery cable assembly (found in hydraulics box) and 9-pin vehicle harness (found in harness kit). Place plug covers over molds on harnesses.

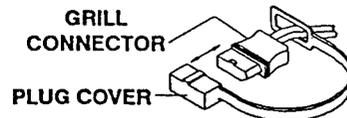

- Find a location on the vehicle grill on the battery side for mounting the battery cable grill connector. The best location is at least 10-1/2" from the center of the grill and at a convenient height for connecting the plow plugs.

Grill openings less than 3/4" high:

Allow grill connector of each harness to hang out in front of grill. Allow enough cable so it is easy to mate and remove connectors. Secure harness behind grill with cable ties.

Grill openings more than 3/4" high:

Use panel mount plates (found in mount box) to mount grill connectors to grill. For openings 3/4" to 1-1/4" mount the plates in front of the grill. For openings larger than 1-1/4", mount plates behind the grill (this will conceal the connector when not in use), making sure connectors can be easily mated.

If using mount plates, slide grooves of grill connectors into the large rectangular openings of the panel mount plates. Route the plug cover strap through the opening of the panel mount plates. Secure mount plate to grill with long cable ties.

- Route battery cable through the grill at the selected location and through or around the radiator bulkhead to motor relay avoiding sharp edges, and hot or moving parts.
 - Attach cable with red stripe to the unused large terminal on the motor relay, and secure it with a lock washer and 5/16"-24 jam nut.
 - Attach cable without stripe to a ground bolt on engine or directly to the NEGATIVE battery terminal (separate the two cables as needed to reach ground bolt or battery).
 - Find a location in grill on driver-side for mounting the 9-pin vehicle harness (similar position to battery cable mount). See Steps 6 & 7 above for how to mount. Route 9-pin vehicle harness through grill and around, or through radiator bulkhead (drill 5/8" hole if needed) into engine compartment.
 - Route the wires that break out of the 9-pin vehicle harness to the area behind the driver-side headlamp. Route rest of harness to the firewall. Drill a 5/8" hole through the firewall in a convenient location away from hot or moving engine parts. Feed fuse holder through hole and then feed the plastic connector and harness through to the cab.
 - Route brown/red and black/orange wire loom to motor relay. Attach each ring terminal to a separate small terminal on motor relay using a lock washer and #10-32 nut for each terminal.
 - Reconnect vehicle ground cable to NEGATIVE battery terminal.
 - Inside the cab, route 9-pin vehicle harness connector to solenoid control and couple the connectors together.
 - Locate an accessory wire that is controlled by the ignition switch (power is turned off when ignition switch is in the "OFF" position). Route the 10 amp fuse holder red wire to this location and trim excess length (leave 10 amp fuse holder in system). Open blue self-stripping connector and place the end of the red wire against the inner groove stop (end of wire must not extend from the connector when it is closed), and the accessory wire in the outer groove. Close connector over the wires using a pliers and snap the locking tab into place.
- OPTION on GM vehicles: Locate an unused fuse box terminal operated by the ignition switch and attach a terminal (not furnished) to the red wire and plug into fuse box terminal.

REMINDER: To prevent corrosion on all underhood electrical connections, use dielectric grease to fill receptacles, including grill connectors, and lightly coat ring terminals and blades before assembly or lightly coat connections after assembling.

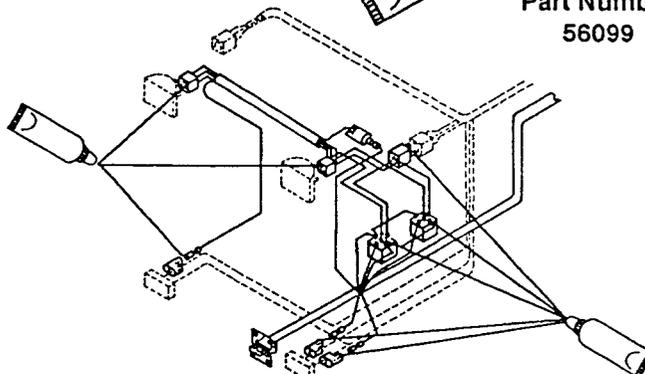
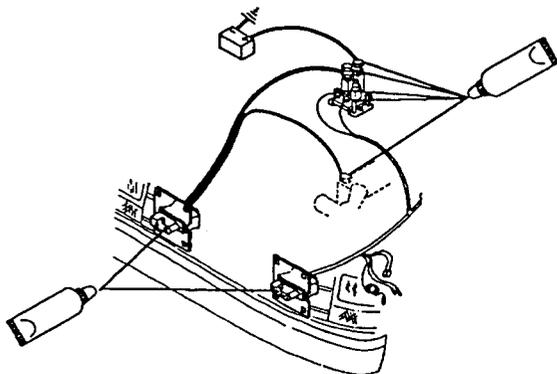

VEHICLE HEADLAMP WIRING DIAGRAM (Dual headlamps shown – For Quad headlamps see next page)

DUAL VEHICLE HEADLAMP PLUG-IN HARNESS & HEADLAMP RELAY INSTALLATION

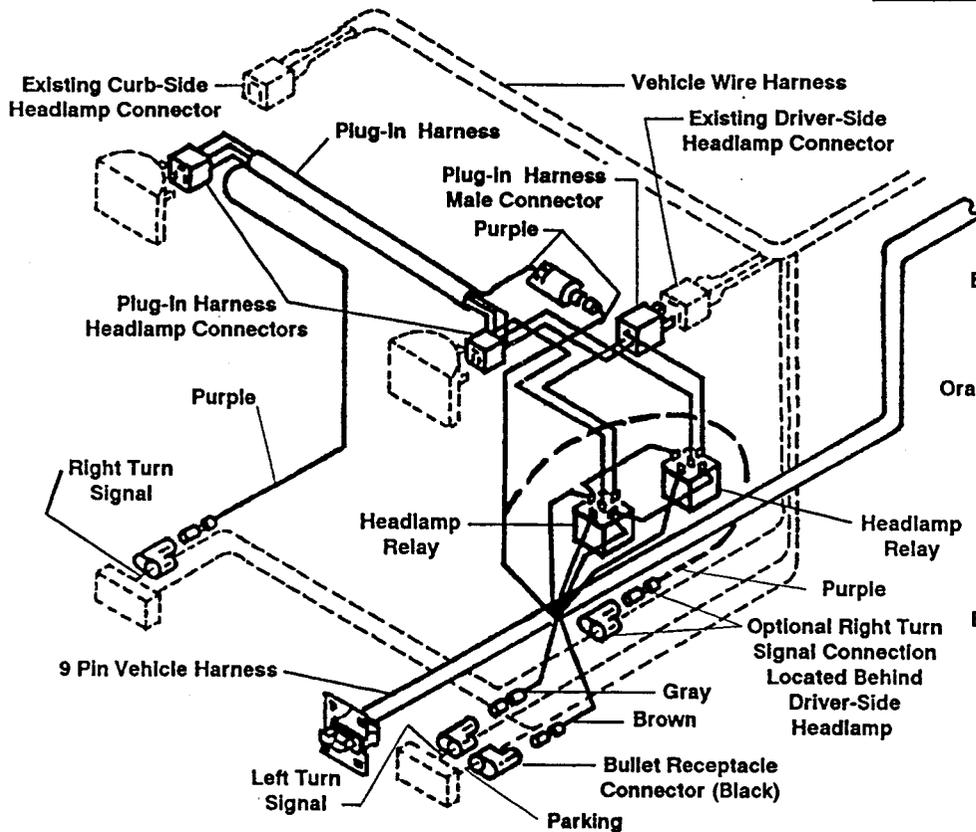

HEADLAMP RELAY WIRING DIAGRAM Type – A

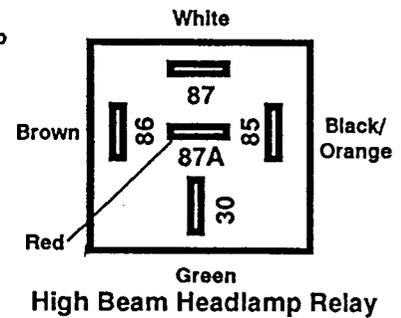
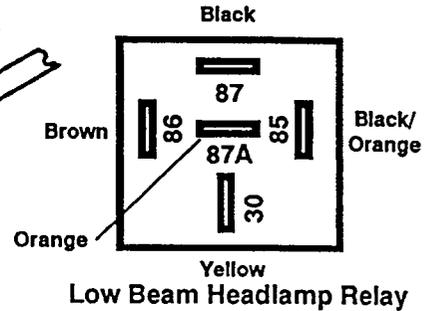

Dual Vehicle Headlamp Plug-in Harness & Headlamp Relays

REMINDER: Lubricate all receptacles and blades with dielectric grease before assembling.

- In the engine compartment behind the driver-side headlamp, insert wire bullets from 9 pin vehicle harness into black bullet connectors (installed in step #1 of previous section) as follows:
 - Brown wire to parking lamp wire on driver-side.
 - Gray wire to left turn signal wire on driver-side.
 - If optional bullet connector location is used – vehicle harness purple wire to right turn signal wire on driver-side.
 - At the vehicle driver-side headlamp, remove the connector from the headlamp and couple matching connector with plug-in harness 3-wire male plug (plug-in harness found in harness kit). Attach plug-in harness headlamp connector to headlamp terminals.
 - Route other end of plug-in harness along radiator bulkhead or over radiator shroud to curb-side headlamp. Remove headlamp connector and secure connector with a cable tie (found in harness kit). Attach plug-in harness headlamp connector to headlamp terminals.
- Skip steps 4 & 5 if optional right turn signal connector location is used. Purple wire in plug-in harness is not used.
- On the curb-side, insert purple wire bullet from plug-in harness into vehicle turn signal black bullet connector installed in step # 1 of the previous section.
 - At the driver-side headlamp, insert the purple wire bullet from the vehicle harness into the purple wire receptacle on the plug-in harness.
 - At driver-side headlamp, connect 9 pin vehicle and plug-in harness wires with receptacles to the two headlamp relays (found in harness kit) as shown in the above diagram.
 - Place grommet around 9 pin vehicle harness and insert into firewall hole (also put a grommet in the hole in the radiator bulkhead if one was drilled). Use cable ties (found in harness kit) to secure harnesses, relays and wires away from hot or moving engine parts and to prevent accidental grounding of connections.
 - This vehicle does not require a change of the turn signal flasher.
 - Lubricate terminal cavities of both grill connectors with dielectric grease. Furnish dielectric grease tube to vehicle owner for future lubrication of grill connectors.

**QUAD VEHICLE HEADLAMP
PLUG-IN HARNESS & HEADLAMP
RELAY INSTALLATION**

VEHICLE HEADLAMP WIRING DIAGRAM
(Quad headlamps shown – For Dual headlamps see previous page)

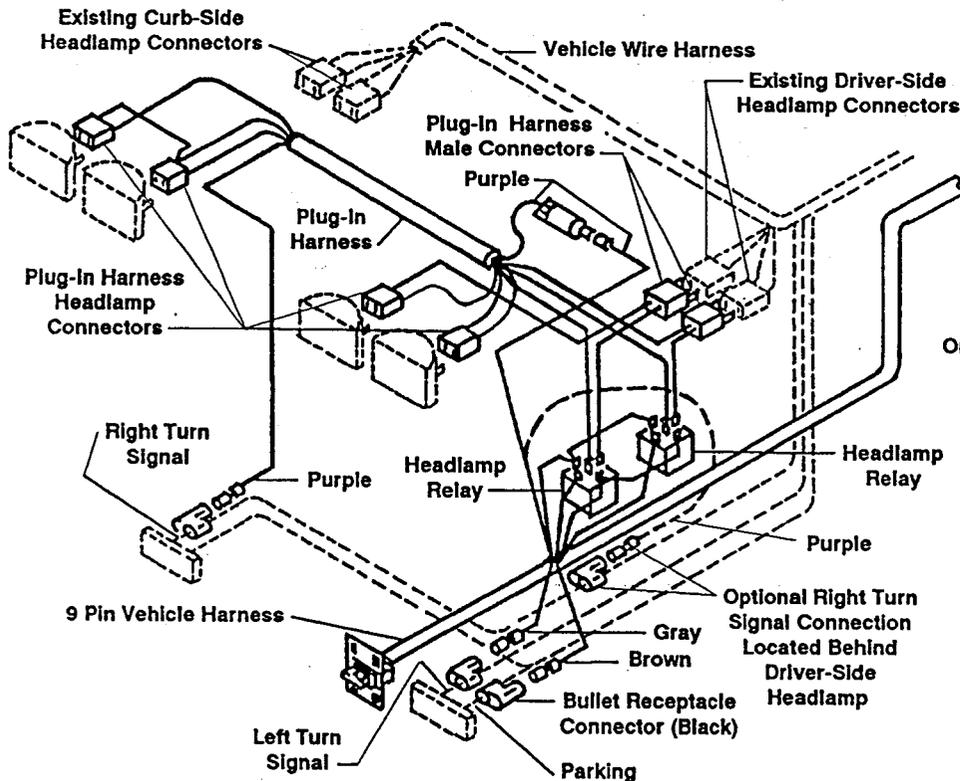

**HEADLAMP RELAY
WIRING DIAGRAM
Type - A**

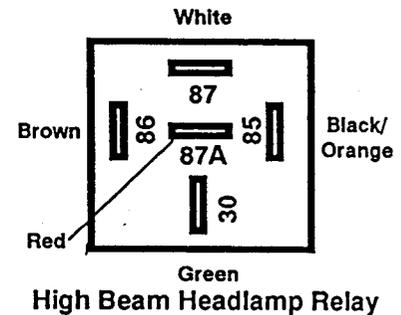
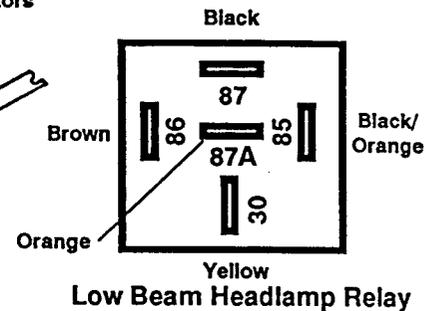

Quad Vehicle Headlamp Plug-in Harness & Headlamp Relays

REMINDER: Lubricate all receptacles and blades with dielectric grease before assembling.

- In the engine compartment behind the driver-side headlamp, insert wire bullets from 9 pin vehicle harness into black bullet connectors (installed in step #1 of previous section) as follows:
Brown wire to parking lamp wire on driver-side.
Gray wire to left turn signal wire on driver-side.
If optional bullet connector location is used – vehicle harness purple wire to right turn signal wire on driver-side.
- NOTE:** Remove park/turn lamp housing to access headlamp connectors on quad composite type headlamps. At the vehicle driver-side headlamp, remove the connectors from the headlamps and couple matching connectors with plug-in harness two 2-wire male plugs (plug-in harness found in harness kit). Attach plug-in harness headlamp connectors to headlamp terminals.
- Route other end of plug-in harness along radiator bulkhead or over radiator shroud to curb-side headlamps. Remove headlamp connectors and secure connectors with a cable tie (found in harness kit). Attach plug-in harness headlamp connectors to headlamp terminals.
- Skip steps 4 & 5 if optional right turn signal connector location is used. Purple wire in plug-in harness is not used.
- On the curb-side, insert purple wire bullet from plug-in harness into vehicle turn signal black bullet connector installed in step # 1 of the previous section.
- At the driver-side headlamps, insert the purple wire bullet from the vehicle harness into the purple wire receptacle on the plug-in harness.
- At driver-side headlamp, connect 9 pin vehicle and plug-in harness wires with receptacles to the two headlamp relays (found in harness kit) as shown in the above diagram.
- Place grommet around 9 pin vehicle harness and insert into firewall hole (also put a grommet in the hole in the radiator bulkhead if one was drilled). Use cable ties (found in harness kit) to secure harnesses, relays and wires away from hot or moving engine parts and to prevent accidental grounding of connections.
- This vehicle does not require a change of the turn signal flasher.
- Lubricate terminal cavities of both grill connectors with dielectric grease. Furnish dielectric grease tube to vehicle owner for future lubrication of grill connectors.

OPERATIONAL TESTS AND ADJUSTMENTS

Mount plow assembly to vehicle. (See label on back of blade or owner's manual for mounting instructions.)

Filling Hydraulic Unit

1. Push lift channel all the way down.
2. Remove fill plug and fluid level plug.
3. Fill unit through fill plug hole until fluid runs out of fluid level hole. Replace both plugs.

Use: automatic transmission fluid (ATF) Dexron IIe to -10° F (-23° C),
WESTERN® High Performance Fluid to -25° F (-32° C),
Texaco 1537 Aircraft Hydraulic Oil for temperatures below -25° F (-32° C).

4. Turn ignition (key) switch to the "ON" or "ACCESSORY" position.
5. Turn the control ON/OFF switch to the "ON" position.
6. Move control lever to angle left and angle right several times to remove air from Hydra-Turn® rams. **DO NOT raise blade as this may cause pump cavitation.**
7. Refill unit with fluid following the procedure in Step 3 of this section.
8. Move the control lever as indicated on label to control the plow. Raise and lower plow several times to remove air. Recheck fluid level according to Step 3 of this section.

Capacity: Solenoid ISARMATIC® Mark IIIa reservoir 1-3/4 quarts
Equipped with 10" Hydra-Turn® rams 2-3/8 quarts

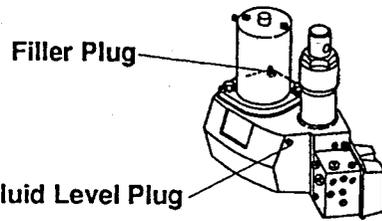

CAUTION: To prevent accidental movement of plow, always turn the solenoid control to the "OFF" position when the mounted plow is not in use.

Blade Drop Speed Adjustment

The quill on the top rear of the valve manifold (see diagram) adjusts blade drop speed.

Turn quill IN (clockwise) to decrease drop speed.

Turn quill OUT (counterclockwise) to increase drop speed.

NOTE: Turning quill too far in can slow raise time

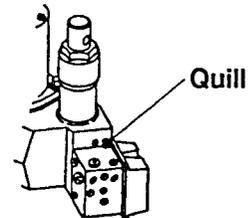

COUPLING LUG HEIGHT CHECK

Coupling Lug Height Check:

1. Mount plow to vehicle (see label on back of blade or owner's manual for mounting instructions).
2. Lift plow and move vehicle. Travel a minimum of 10 feet. Lower blade.
3. After step 2, with: blade on level surface,
slack in lift chain,
rear ballast located behind rear wheels,
center of coupling lug holes (hitch pin shaft) to level surface should measure 9-1/2" to 10-1/2". To obtain height, adjust spreader position.

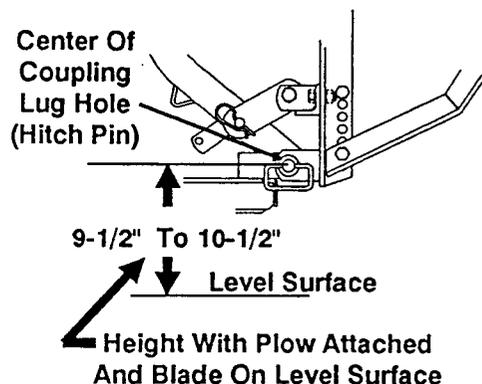

NOTE: Coupling height must be 9-1/2" minimum to allow stand to be pinned to lift frame.

4. Adjust chain slack with plow mounted to vehicle and lift channel pushed all the way down. To adjust, remove chain from hook. Straighten chain and pull tight. Rehook it to lift channel. After it is hooked, it will have the correct amount of slack for blade "float". **DO NOT** remove chain from lift channel when removing plow from vehicle.

Final Hydraulic Inspection

1. Make sure all fasteners and hydraulic and electrical connections are tight.
2. Check ram packing nuts for oil leakage. If any leakage is observed, tighten the packing nut 1/4 turn after you feel the nut contact the packing. Do not overtighten – overtightening affects cylinder operation and shortens the life of the packing. A short period of normal operation will allow chevron packings to become saturated, and leakage will normally stop.

VEHICLE LIGHTING CHECK**Vehicle Lighting Check**

1. Check the operation of vehicle and plow lights.

Turn signals and parking lamps:

Parking lamps ON Both vehicle and plow lamps should be on at the same time.
Right Turn Signal ON Both vehicle and plow lamps should flash at the same time.
Left Turn Signal ON Both vehicle and plow lamps should flash at the same time.

Headlamps:

Move vehicle headlamp switch to the "ON" position. Connecting and disconnecting the 9- or 12-pin plow plug from the grill connector should switch between vehicle and plow headlamps as follows:

9- or 12-pin plow plug DISCONNECTED Vehicle headlamps should be on, plow headlamps off.
9- or 12-pin plow plug CONNECTED Plow headlamps should be on, vehicle headlamps off.

Dimmer switch should dim whichever headlamps are operating. The high beam indicator on the dash should light when either set of headlamps is on high beam.

Solenoid Control:

The control indicator light should light whenever the control ON/OFF switch and the ignition (key) switches are both in the "ON" position and the plow plugs are connected to the grill connectors.

2. Connect plow plug to grill connector. Raise plow and aim plow headlamps according to SAE J599 Lighting Inspection Code (See Service Bulletin SP 608) and any applicable federal, state, or local regulations.
3. Check aim of vehicle headlamps with plow removed.
4. When plow is removed from the vehicle, install plug covers on grill connectors and insert the plow plugs into the boot on the hydraulic unit.

NOTE: After 5 to 10 hours of snowplow usage, retorque all mount assembly fasteners.

Unimount[®]

Solenoid Control - The control indicator light should light whenever the control ON/OFF switch and the ignition (key) switch are both turned ON and the plow plugs are connected to the grill connector.

Form No. 13591

Wiring Diagram Harness Type - A w/ 9 Pin Headlamp Kit & SAE Headlamp Types 2B/2D HB-1 HB-5

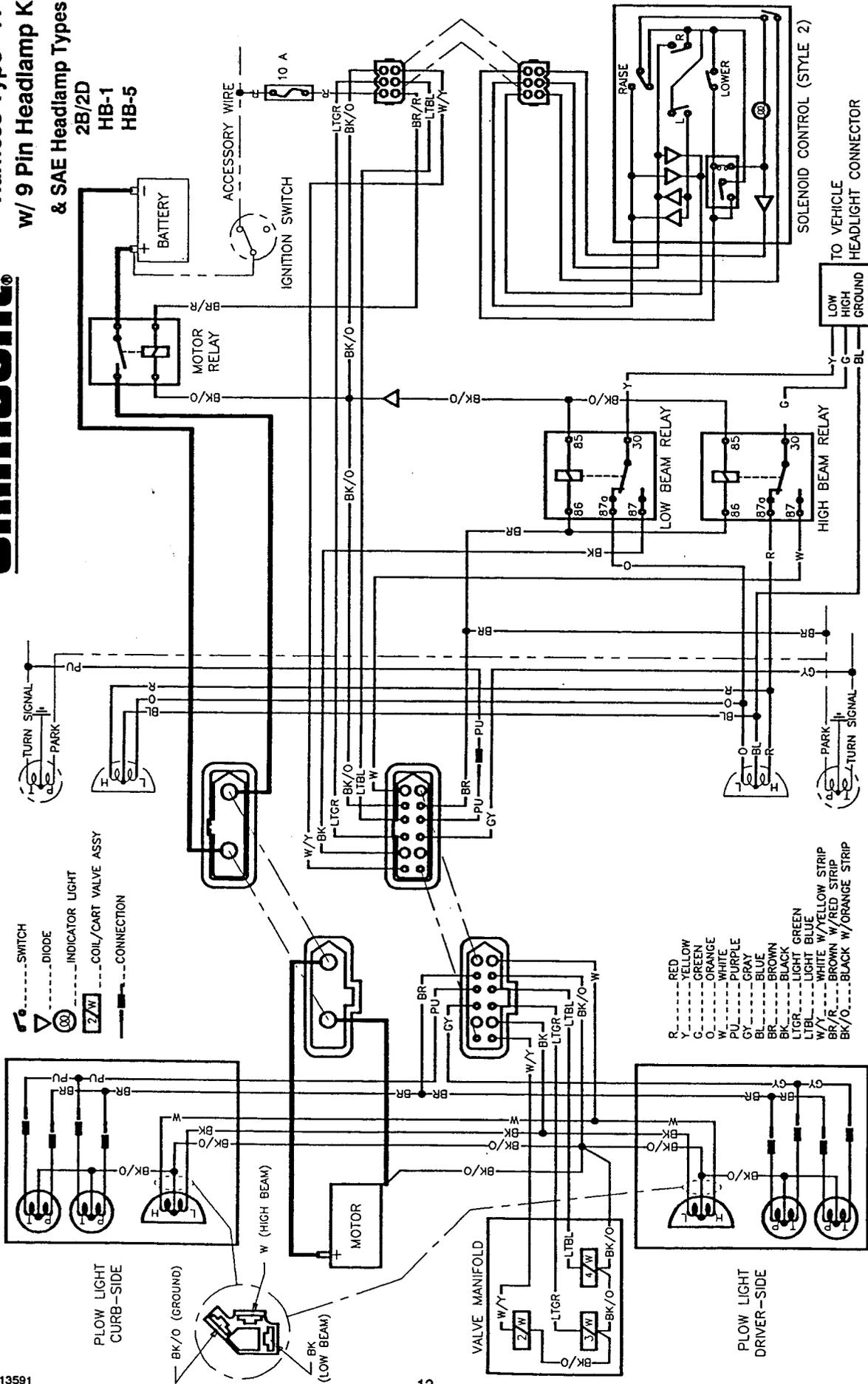

Vehicle harnesses - 9 pin, P.N. 61437 rev. 7 or 12 pin, P.N. 61557, rev. 5 and later - The indicator light on the solenoid control will only light when the plow is attached to the vehicle and the ignition switch and control on/off switch are both turned on.

Vehicle harnesses with revision numbers prior to listed revisions at right - The indicator light will also be on when the control and ignition (key) switches are ON and the plow plugs are disconnected. If the parking lights are turned on (with plow plugs disconnected), the indicator light will go out.

This page is intentionally blank.

This page is intentionally blank.

Mount Assembly Box No. 61440
 Harness Kit Box No. 61545 or 61515 or 61580
 Hydraulics Box No. 56365
PARTS DIAGRAM & LIST

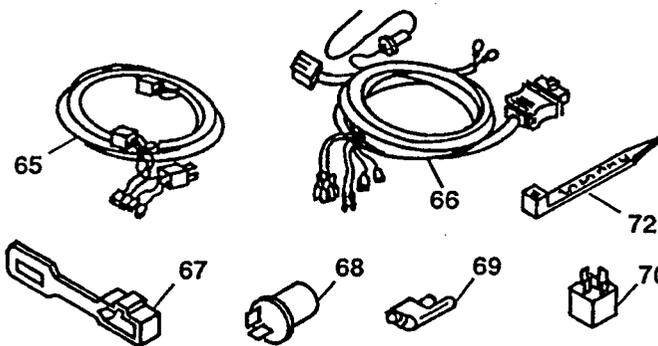
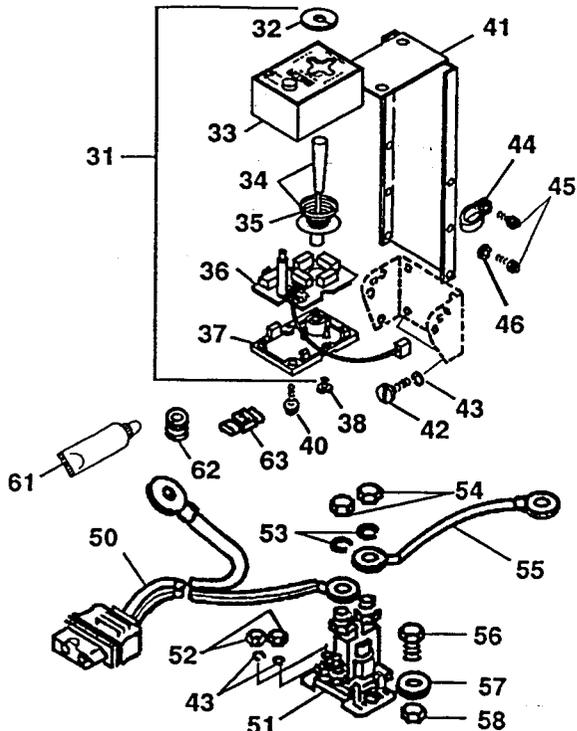

ITEM PART NO. QTY. DESCRIPTION

Found in Harness Kit Box No. 61545, 61515, or 61580

65	61546	1	PLUG-IN HARNESS 2B/2D U -A (For Harness Kit No. 61545)
	61716	1	PLUG-IN HARNESS HB-3 & HB-4 U -A (For Harness Kit 61515)
	61581	1	PLUG-IN HARNESS LF & UF U -A (For Harness Kit 61580)
66	61437	1	VEHICLE HARNESS 9-PIN U
67	61548	2	PLUG COVER U
68	60109	1	FLASHER HD
69	59224	3	BULLET RECEPTACLE CONNECTOR
70	61535	2	HEADLAMP RELAY SPDT
72	59223	8	CABLE TIE

Parts listed above may be found in the following assembly.

61547	1	PARTS BAG
-------	---	-----------



90

85

83

Found in Mount Box No. 61440

83	61539	1	PANEL MOUNT PLATE SET - SHORT
85	61536	8	CABLE TIE - LONG
90	56080	1	DASH BRACKET

Parts listed above may be found in the following assembly.

61722	1	BOLT BAG ASSY (61440)
-------	---	-----------------------

		Abbreviations	
ASSY	Assembly	SL	Slotted
BP	Black Phosphate	SP	Spring
BPO	Black Phosphate & Oil	SPDT	Single Pole Double Throw
BZP	Black Zinc Plate	STD	Standard
CS	Cap screw	SYS	System
G	Grade	TCTS	Thread Cutting Tapping
HD	Heavy Duty		Screw
HX	Hex	TFTS	Thread Forming Tapping
HXW	Hex Washer		Screw
LK	Lock	TY	Type
NYIS	Nylon Insert	U	UniMount® System
PC	Printed Circuit	W/	With
PN	Pan	ZP	Zinc Plate
PT	Prevailing Torque		

Indented part numbers are included in the assembly under which they are listed. Quantities shown are included with the assembly.

ITEM PART NO. QTY. DESCRIPTION

Found in Hydraulics Box No. 56365

31	56369	1	SOLENOID CONTROL (Style 2)
32	56283	1	SHIELD
33	49286	1	BODY W/LABEL & LENS (Style 2)
34	49287	1	LEVER, SPRING & ACTUATOR KIT (Style 2)
35	55923	1	SPRING - CONICAL
36	49283	1	PC BOARD ASSY MOLEX (Style 2)
37	56199	1	BASE
38	93153	2	#6-19X3/8 SL HXW TFTS HILO
40	93154	2	#8-18X5/8 SL HXW TFTS HILO
41	56308	1	CONTROL BRACKET
42	90388	4	#10X1 SL PN TFTS TY AB BZP
43	91242	4	#10 SP LK WASHER BPO
44	55381	1	CABLE CLAMP
45	93157	5	#8-32X3/8 SL HXW TCTS TY T BP
46	91231	4	#8 SP LK WASHER BP
50	61169	1	CABLE ASSEMBLY - VEHICLE
51	56134K	1	RELAY-SOLENOID HYDRAULIC SYS
43	91242	2	#10 SP LK WASHER BPO
52	91402	2	#10-32 HX NUT ZP
53	91202	2	5/16 SP LK WASHER ZP
54	92842	2	5/16-24 HX JAM NUT
55	22511	1	BATTERY CABLE 22" RED
56	90002	2	1/4-20X3/4 HX CS G2 ZP
57	91101	2	1/4 PLAIN WASHER TY A STD ZP
58	91331	2	1/4-20 PT HX LK NUT NYIS ZP
61	56099	1	DIELECTRIC GREASE TUBE
62	66130	2	RUBBER GROMMET
63	59114	1	SELF STRIP WIRE CONNECTOR

Parts listed above may be found in one of these assemblies.

56368	1	CARTON ASSY LOOSE PARTS U
56367	1	BOLT BAG ASSY LARGE U
56358	1	BOLT BAG SMALL U

The following are registered® and unregistered™ Trade Marks of Douglas Dynamics, Inc.
 WESTERN® ISARMATIC® Hydra-Turn® Roll-Action™ PRO-GUARD™ UniMount™

Western reserves the right under its Product Improvement Policy to change construction details and furnish equipment when so altered without reference to illustrations or specifications used here.