

## 1992 - 1998 Ford F350 4X4 81004 ATTACHMENT KIT

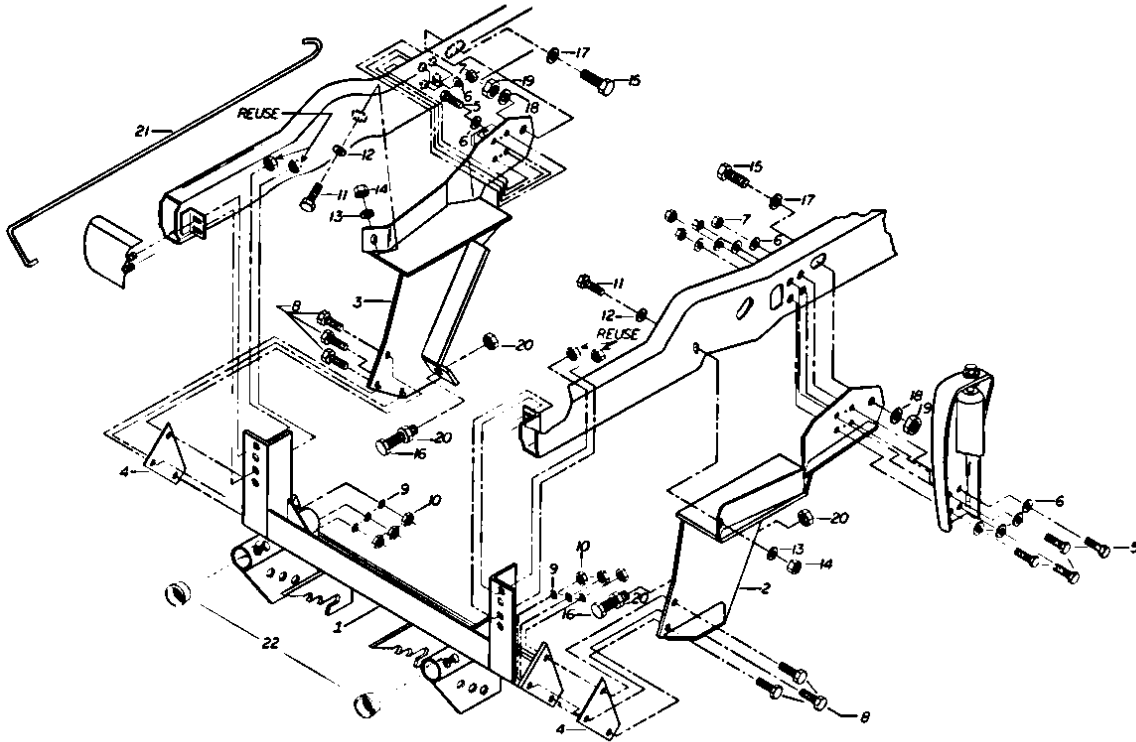

### PARTS LIST

ITEM	STOCK	DESCRIPTION	QTY.	ITEM	STOCK	DESCRIPTION	QTY.
	81004	MOUNTING CARTON		12	* 20357	5/8" FLATWASHER	2
1	815000 086	FRONT MOUNTING FRAME	1	13	* 20331	5/8" FLATWASHER	2
2	815000 103	PUSHARM, DR SIDE	1	14	* 20530	5/8-11 NUT	2
3	815000 104	PUSHARM, PS SIDE	1	15	* 20162	3/4-10 x 2" CAPSCREW	2
4	815000 105	SPACER	2	16	* 20164	3/4-10 x 2" CAPSCREW	2
5	8500014 079	7/16-14 X 2" CAPSCREW	8	17	* 20359	3/4" FLATWASHER	2
6	20354	7/16" FLATWASHER	16	18	* 20333	3/4" LOCKWASHER	4
7	20306	7/16-14 LOCKNUT	8	19	* 8501001 015	3/4-10 NUT	2
8	* 20095	1/2-13x1-1/2" CAPSCREW	6	20	* 5201003 015	3/4-10 JAM NUT	4
9	* 20329	1/2" LOCKWASHER	6	20	819000 013	RELEASE HOOK	1
10	* 8501001 009	1/2-13 NUT	6	21	815000 146	REC. TUBE END CAP	2
11	* 20139	5/8-11 X 1-1/2" CAPSCREW	2				

\*

ITEMS PACKED IN 80071 BOLT BAG

**Parts indented are included in the assembly under which they are indented.**

Diamond Equipment reserves the right, under its continuing product improvement program, to change construction or design details, specifications and prices without notice or without incurring any obligation.



Diamond Equipment  
Old Route 1 RR #1 • Damariscotta, ME 04543-9720  
Phone 563-2227 (Area Code 207)  
www.diamondplow.com • email info@diamondplow.com

**PARTICULAR ATTACHMENTS INSTRUCTIONS  
FOR 81003 PULL AWAY MOUNTINGS**

**IMPORTANT NOTICE**

**End user must be given this instruction sheet prior to delivery of this Snow Plow.**

The equipment you have just purchased should only be used on vehicles equipped with the Manufacturer's Snow Plow Preparation Packages. Snow Plowing without the original Snow Plow Preparation Package may damage your vehicle and the added weight to the equipment may impair the operation and control of the vehicle. Snow Plowing with a vehicle that the manufacturer does not recommend for that purpose may void your new vehicle warranty. If your vehicle is not originally equipped with the Snow Plow Package, additional parts may be necessary before snow plowing. Owners of these vehicles should consult their dealers before purchase or installation of such parts. CAUTION: the installation, on any vehicle, of these parts is not a full substitute for the original equipment Snow Plow Preparation Package.

**Warning: Lift Arm extends beyond bumper of vehicle. To minimize damage from a front-end collision, Lift Arm should be removed from vehicle when Snow Plow is removed.**

**GENERAL INSTRUCTIONS:** Disconnect the vehicle battery or batteries before beginning installation. (Reconnect after installation is complete.) Do not burn holes into or weld pieces onto the vehicle frame. Use extreme caution when drilling any holes in the vehicle to prevent damage to brake lines, fuel lines, wiring, or any other vehicle components. Assemble parts and fasteners "finger tight" until instructions indicate final tightening. After first usage and periodically thereafter, re-tighten all fasteners to correct torque.

**NOTE:** 1/2"-13 GRADE 5 fasteners should be torqued to 75 ft. lbs.  
5/8"-11 GRADE 5 fasteners should be torqued to 150 ft. lbs.  
3/4"-10 GRADE 5 fasteners should be torqued to 250 ft. lbs.

1. **PRELIMINARY:** Jack the vehicle up from under the center of the frame until the front tires just clear the ground. Place jack stands under the frame to prevent accidental lowering of the vehicle. Screw a 3/4"-10 jam nut (20) all the way on to each of the 3/4"-10 X 2" capscrews (16). Place each of the 3/4"-10 X 2" capscrew / jam nut assemblies through the hole in the lower front ear of the driver's side and passenger's side push arms (2),(3), with the heads of the capscrews (16) toward the front of the vehicle. Fasten with a 3/4" lockwasher (18) and 3/4"-10 jam nut (20) on each capscrew (16). Remove and discard the two capscrews and nuts on 1992 - 1993 vehicles or the four capscrews and nuts on 1994 vehicles holding each front shock absorber bracket to the frame rails. If this attachment kit is being installed on a 1992 or 1993 vehicle, ream out the two 5/16" DIA. holes in the rear frame plate section of each push arm (2),(3) to 9/16" DIA.
2. **DRIVER'S SIDE PUSH ARM:** Place the rear upper section of the driver's side push arm (2) up and out through the space between the top of driver's side spring and the bottom flange of the vehicle frame rail. Align the holes in the rear plate of the push arm with the shock absorber bracket holes in the vehicle frame.



Place the shock absorber bracket against the rear plate of the push arm and install (depending on the year of the vehicle), either two or four 7/16" x 2" capscrews (5) with 7/16" flatwashers (6) through the bracket, the rear plate of the push arm, the vehicle frame rail and fasten using 7/16" flatwashers (6), and 7/16"-14 locknuts (7). Install a 3/4"-10 X 1-1/2" capscrew (15) and 3/4" flatwasher (17) out through the slotted hole in the frame rail just behind the shock absorber bracket and through the rear plate of the push arm (2). Fasten using a 3/4" lockwasher (18) and a 3/4"-10 nut (19). Install a 5/8"-11 X 1-1/2" capscrew (11) and 5/8" flatwasher (12) out through the frame rail and the forward hole in the rear portion of the push arm (2).

**NOTE: Although the vehicle frame rail is boxed and access to the front slotted hole is limited if the vehicle has a diesel engine, it is possible to install the 5/8-11 X 1-1/2" capscrew (11) and 5/8" flatwasher (12) into the inside of the boxed frame by inserting a 12" length of small diameter mechanics wire in through the hole in the front ear on the push arm, through the slotted hole in the frame rail, and out through the open front end of frame rail. Attach the wire to the threaded end of 5/8-11 X 1-1/2" capscrew (11) and 5/8" flatwasher (12). Use the wire to pull the capscrew (11) and flatwasher (12) in through the slotted hole in the frame and hole in the ear on the push arm (2). Fasten using a 5/8" lockwasher (13) and a 5/8"-11 nut (14).**

3. **PASSENGER'S SIDE PUSH ARM:** Install the passenger's side push arm (3) in the same manner and with the same number and type of fasteners as described for attaching the driver's side push arm.
4. **MOUNTING FRAME:** Remove and save the four metric flange nuts holding the front bumper brackets to the front end of the vehicle frame rails. Place the upright hanger angles of the mounting frame (1) up behind the front bumper mounting brackets on the frame rails with the bumper bracket bolts through the upper set of holes in the upright hanger angles. Fasten using the four metric flange nuts removed from the bumper bracket bolts earlier. Line up the three holes in the front section of each push arm (2),(3) with the holes in the end plates of the push angle on the mounting frame (1). Insert a spacer (4) between each push arm (2),(3) and each end plate of the push angle on the mounting frame (1). Fasten each of the push arms (2),(3) to the mounting frame (1) using three 1/2"-13 X 1-1/2" capscrews (8), 1/2" lockwashers (9) and 1/2"-13 nuts (10). Remove jack stands from under frame and lower vehicle to the ground.
5. **FASTENERS:** Align the front bumper and the mounting frame (1) so that they are centered with the grill and level with the ground. Tighten the four metric flange nuts holding the bumper brackets and mounting frame (1) to the vehicle frame. Hold the push arms (2),(3) tight against the outside and bottom flange of the frame rails and tighten the fasteners holding them to the vehicle frame. Adjust the 3/4" capscrews (16) with the 3/4" jam nuts (20) so that the heads of the capscrews are tight against the push angles of the mounting frame. Lock the 3/4" capscrews (16) in place using the rear jam nuts (20). tighten the 1/2" fasteners holding the push arms (2),(3) to the mounting frame (1).



- 6. LIFT FRAME:** Clean paint and burrs from the outside tube ends of the lift frame and the inside surfaces of the receiver tubes of the front mounting frame (1).

**SPECIAL NOTE: Liberally coat the entire tube ends of the lift frame, the inside surfaces of the receiver tubes and threads of the slack adjusting bolts on the receiver tubes with chassis grease or anti-seize lubricant.**

**Back** off the slack adjusting bolts on the receiver tubes until they no longer protrude inside the tubes. Slide the lift frame into the receiver tubes of the front mounting frame (1) until the fastening holes line up. Tighten the slack adjusting bolts on the receiver tubes until the lift frame will just slide in and out of the receiver tubes. Secure the lift frame to the front mounting frame using 5/8" hinge pins (26) and hairpin cotters (27).

- 7. LIFT ARM:** Install the lift arm (24) and lift cylinder or electric hydraulic unit onto the lift frame using the 5/8"-11 X 5-1/2" capscrew (25) through the upper lift frame ears and the rear lift arm hole. Place a 5/8"-11 X 4-3/4" capscrew through the front lift arm hole and the ram end of the lift cylinder or electric hydraulic unit. Place a 5/8"-11 X 3-1/4" capscrew through the lower lift frame ears and stationary end of the lift cylinder or electric hydraulic unit. Fasten the three 5/8"-11 capscrews using three 5/8"-11 locknuts (32).
- 8. LIFT CHAIN:** Attach each end of the lift chain (40) to the two holes in each of the diagonal braces of the push frame using 7/16" -14 "U" bolts (41), 7/16" lockwashers (43), and 7/16"-14 nuts (42).
- 9. PUSH FRAME:** Install the push frame onto the plow blade with the upper and lower pivot holes lined up with the pivot holes in the back of the plow blade. Insert the shorter pivot pin (36) down through the upper pivot holes. Insert the longer pivot pin (39) down through the lower pivot holes. Secure the pivot pins (36),(39) using 1/4" X 2" cotter pins (23).
- 10. ANGLE CYLINDERS:** Install the angle cylinders between the push frame and the ears on the back side of the plow blade with the rod end of the cylinders toward the plow blade. The elbows in the ports of the angle cylinders should be between the angle cylinders and the push frame.

**NOTE:** When installing the angle cylinders on 8' and 8-1/2' plow blades, place four 1-1/4" flatwashers (30) between each **lower push frame ear and** the stationary end of each angle cylinder.

Attach the stationary end of the angle cylinders to the push frame using the two shorter cylinder pins (22). Attach the rod ends of the angle cylinders to the back side of the plow blade using the two longer cylinder pins (44). Secure the cylinder pins using 1/4" X 2" cotter pins (23).

11. **PLOW MARKERS:** Attach each plow marker (33) to the two holes in the upper outer surface of each end rib of the plow blade using two 5/16"-18 X 1" capscrews (35), 5/16" lockwashers (37), and 5/16"-18 nuts (38).
  12. **HOOK UP PINS:** Compress each hook up pin spring (50) slightly and place them between the inner most ear and the center ear on each side of the push frame with the hole through the center of each spring lined up with the pin holes in the push frame ears. Insert each hook up pin (48) through the pin hole in each inner most ear of the push frame , through the center of the springs (50), and out through the center and outside ears on each side of the push frame. Compress the hook up pin springs (50) slightly and secure the hook up pins (48) using a 1" snap ring (49) in the snap ring groove of each hook up pin (48). (The **snap rings should be between the end of the spring and the inner surface of each of the center ears on the push frame.**)
  13. **PLOW TO VEHICLE ATTACHING:** Pull back and lock the spring loaded hook up pins (48) on each side of the push frame . Attach the lift chain to the lift arm hooks and lift the back end of the push frame up level using the vehicle hydraulics. Line up the spring loaded hook up pins with the corresponding set of holes in the lower part of the mounting frame. Unlock the spring loaded hook up pins so that they go completely through the holes in the mounting frame and the push frame ears. Adjust the lift chain at the lift chain hooks on the lift arm so that the plow blade will lift fully and also be able to follow the ground contour while plowing.
- NOTE: If the lift chain does not pull **evenly, shorten** the longer side by attaching at a different link or at half **a link** where the chain is attached to the push frame with the 7/16" "U" **bolts**.
14. **PUSH FRAME STOP BOLTS:** Screw a 5/8"-11 jam nut (29) all the way onto each of the 5/8"-11 X 3" full thread capscrews (28).



Place the capscrew / jam nut assemblies up through the ears on each side of the lower lift frame with the heads of the capscrews down. Fasten with a 5/8" lockwasher (31) and jam nut (29). Adjust the 5/8"-11 X 3" full thread capscrews (28) with the jam nuts (29) so that the heads of the capscrews (28) contact the push frame before the upper pivot section of the push frame contacts the lift arm or the lift cylinder / out front electric hydraulic unit while lifting plow or stacking snow.

**NOTE: If the push frame is attached to a different set of connecting holes on the mounting frame, the push frame stop bolts should be checked and may need to be readjusted to prevent the push frame from contacting the lift arm, or the lift cylinder / out front electric hydraulic unit while lifting plow or stacking snow.**

**CAUTION: CHECK THE TRIPEDGE ADJUSTMENT AT THIS TIME.**

A. THE SPRINGS ARE PROPERLY ADJUSTED WHEN A PIECE OF PAPER CAN BE PLACED BETWEEN THE COILS.

B. IF THE TRIPEDGE SPRINGS NEED ADJUSTMENT, LOOSEN THE BOTTOM LOCK NUT ON BOTH SPRING ASSEMBLIES. ROTATE THE TOP NUT UNTIL THE SPRINGS ARE PROPERLY ADJUSTED.

C. BE SURE TO TIGHTEN THE BOTTOM LOCK NUT SECURELY ON BOTH ASSEMBLIES TO THE TOP NUT TO PREVENT LOOSENING OF THE ASSEMBLIES.

**NOTICE: Diamond Equipment or Meyer Products assume no responsibility for installations not made in accordance with these instructions.**

**Instructions are subject to change without notice.**