

FORM NO. 63293
November 1, 1998



UniMount^{SYSTEM}

JEEP WRANGLER 4X4 1997 AND LATER INSTALLATION INSTRUCTIONS

This installation requires vehicle to be fitted with
a MOPAR air shock kit #82202562

Model No. 3715
Mount assembly Box No. 63250
Hydraulics Box No. 56355
Harness Kit No. 61530

⚠ CAUTION

See your WESTERN® outlet for application
recommendations. The selection list has
specific vehicle and snowplow requirements.

SAFETY

GENERAL SAFETY

WARNING

Indicates a potentially hazardous situation that, if not avoided, could result in death or serious injury.



CAUTION

Indicates a potentially hazardous situation that may result in minor or moderate injury and/or property damage if not avoided.

NOTE: Identifies tips, helpful hints and maintenance information the owner/operator should know.

CAUTION

Read instructions before assembling. Bolts should be finger tight until instructed to tighten according to the torque chart. Use standard methods and practices when attaching snowplow including wearing safety glasses during cutting, drilling and welding.

Recommended Fastener Torque Chart (Ft.-Lb.)				
Size	 SAE Grade 2	 SAE Grade 5	 SAE Grade 8	
1/4-20	6	9	13	
5/16-18	11	18	28	
3/8-16	19	31	46	
3/8-24	24	46	68	
7/16-14	30	50	75	
1/2-13	45	75	115	
9/16-12	66	110	165	
5/8-11	93	150	225	
Metric Grade 8.8 (Ft.-Lb.)				
Size	Torque	Size	Torque	
M 6	7	M 12	60	
M 8	17	M 14	95	
These torque values apply to mount assembly fasteners except those noted in the instruction.				

MOUNT INSTALLATION

MOUNT FRAME

1. Disconnect any wire harness plugs for fog lamps or driving lights.
2. Remove bumper bolts from top and bottom of bumper.
3. Remove bumper from vehicle. **(See Photo 1.)**



Photo 1

4. Remove forward power steering bolt on outside of frame. **(See Photo 2.)**



Photo 2

5. Insert nut plate into frame tube on both sides. **(See Photo 3.)**



Photo 3

6. Install 7/8" tube spacer into hole rearward of frame tube on passenger-side. **(See Photo 4.)**

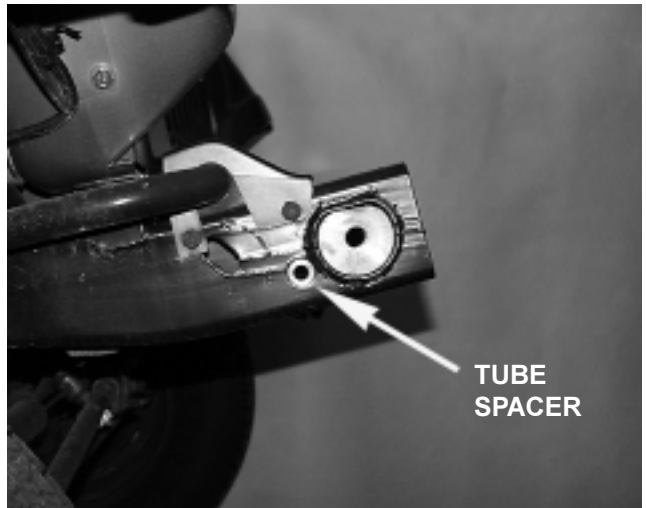

Photo 4

Continued on next page

MOUNT INSTALLATION

MOUNT FRAME- CONTINUED

- Place mount frame against vehicle frame and loosely install 3/4" bolts and lock washer into nut plates, replace power steering bolt and install 1/2" bolts through 7/8" tube spacer installed in step 4.
- Install and align bumper with holes in vehicle frame and assemble hardware removed in step 2 in top and 1/2" flange bolts in bottom two holes of mount. (See Photo 5.)

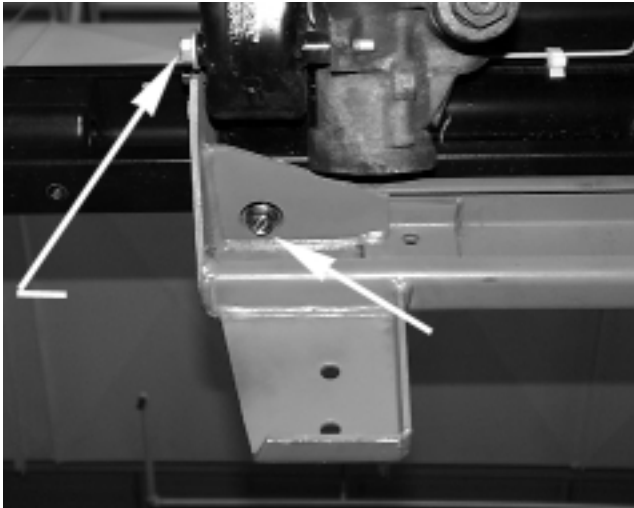

Photo 5

THRUST ARMS

- Assemble and align thrust arms so bottom of U-bracket is against bottom of frame. Assemble front of thrust arms to mount frame and coupling lug using 1/2" x 1-1/2" bolts and lock nuts. (See Photo 6.)



Photo 6



Photo 7

- Keeping thrust arm bracket against frame, tighten all hardware on mount frame.
- Remove tires from front of vehicle.
- Using holes in bracket of thrust arm as a guide, center punch and a drill a 1/2" hole through inner and outer walls of frame and other side of U-bracket.
- Using a 3/4" drill open up the outer hole in the frame.
- Insert 3/4" tube spacer with 1/2" bolt through thrust arm bracket and frame, and attach 1/2" lock nut. (See Photo 7.)

NOTE: After five to ten hours of snowplow usage, retorque all mount assembly fasteners.

HARNESS KIT SELECTION

NOTE: Plow may be removed from vehicle for installation of electrical components.

NOTE: During electrical installation, the LONG BATTERY GROUND CABLE (no stripe) MUST BE GROUNDED TO THE NEGATIVE BATTERY TERMINAL

- For 2B headlamps use: Box No. 61540 Headlamp Kit and 61530 Harness Kit 2B1 9-Pin-C.

SOLENOID CONTROL INSTALLATION

SOLENOID CONTROL - FLOOR MOUNT

1. Align dash bracket hole shown in diagram to end hole of control bracket.

NOTE: Top flange of control bracket may be reversed in dash bracket from position shown in diagram. Attach with one #8 x 5/8" hex head thread cutting screw and lock washer on each side

2. Use top holes in dash bracket (see diagram) as a template to drill a 9/64" hole in each side of control bracket. Secure dash bracket to control bracket with a second screw and lock washer on each side.
3. Secure solenoid control to control bracket with two #8 x 5/8" hex head tapping screws.
4. Move seat forward. Locate control and bracket assembly on floor tunnel so that it does not interfere with the operation of vehicle controls. Mark this location.
5. Remove control bracket from dash bracket.
6. Place dash bracket in marked location. Use dash bracket as a template to drill four 1/8" holes in tunnel.

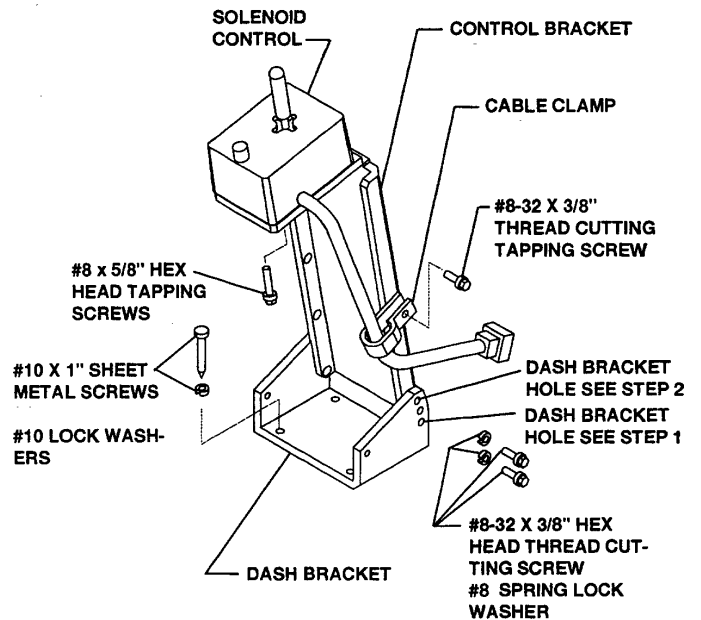

⚠ CAUTION

Before drilling any holes, check both sides of the material for any wires, fuel lines, fuel tanks, etc. that may be damaged by drilling.

7. Secure dash bracket to tunnel with four #10 x 1" sheet metal screws and lock washers.
8. Reassemble control bracket to dash bracket. Bend top flange of control bracket to desired position.
9. Secure harness to control bracket with cable clamp and one #8 x 3/8" hex head thread cutting screw.

UNDER HOOD INSTALLATION

VEHICLE HARNESS AND MOTOR RELAY

NOTE: Except as noted, parts to be installed are found in hydraulics box.

NOTE: Use dielectric grease to prevent corrosion on all under hood electrical connections. Fill receptacles and lightly coat ring terminals and blades before assembly.

HARNESS, SOLENOID CONTROL & MOTOR RELAY INSTALLATION DIAGRAM

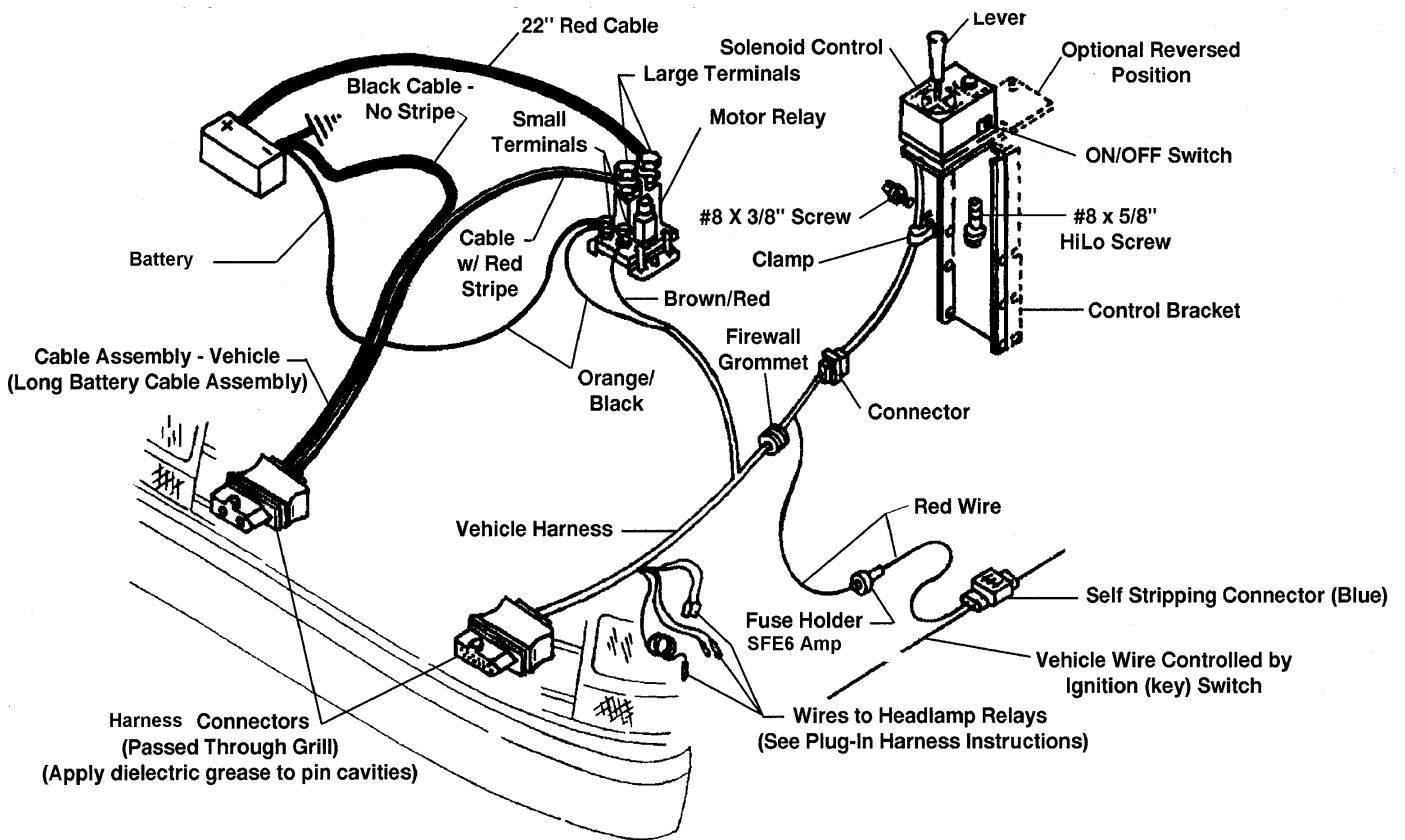

(Continued on next page)

UNDER HOOD INSTALLATION

VEHICLE HARNESS AND MOTOR RELAY - CONTINUED

⚠ CAUTION

Batteries normally produce explosive gases which can cause personal injury. Therefore, do not allow flames, sparks or lit tobacco to come near the battery. When charging or working near a battery, always cover your face and protect your eyes, also provide ventilation.

Batteries contain sulfuric acid which burns skin, eyes and clothing.

Disconnect the battery before removing or replacing any electrical components.

1. Identify wires for the parking lamp on the driver-side and the turn signals on both sides of the vehicle. Attach a black self-stripping bullet receptacle connector (found in harness kit) to each of these three wires.
2. Remove NEGATIVE battery cable from battery.
3. Find a location for the motor relay where it will be protected from road splash and within 18" of the vehicle primary battery.
4. Using the motor relay terminal as a template, drill two 9/32" holes, and mount motor relay to holes using 1/4" x 3/4" bolts, flat washers and lock nuts.

NOTE: Motor relay terminals must be up or horizontal.

5. Route 22" battery cable between a large motor relay terminal and the POSITIVE battery terminal taking care to avoid sharp edges and hot or moving parts. Attach eyelet from fuse holder to same large motor relay terminal. **(See diagram and instructions on previous page.)**
6. Attach cable to motor relay terminal with a lock washer and a 5/16"-24 jam nut. Attach cable to battery POSITIVE terminal with existing hardware.

(Continued on next page)

UNDER HOOD INSTALLATION

VEHICLE HARNESS AND MOTOR RELAY - CONTINUED

- Stretch rectangular openings of plug cover straps (found in harness kit) over harness connector ends of long battery cable assembly (found in hydraulics box) and vehicle harness (found in harness kit). Place plug covers over harness ends.

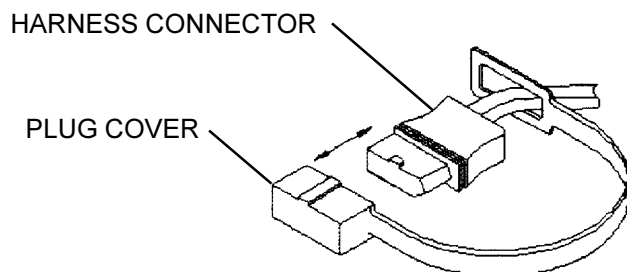

- Find a location in the vehicle grill on the battery side for mounting the battery cable connector. The best location is at least 10-1/2" from the center of the grill and at a convenient height for connecting the plow plugs.
- Allow connector of each harness to hang out in front of grill. Allow enough cable so it is easy to mate and remove connector. Secure with long cable ties (found in mount box).
- Route battery cable through the grill at the selected location and through or around the radiator bulkhead to motor relay. (**Take care to avoid sharp edges, and hot or moving parts.**)
- Attach cable with red stripe to the unused large terminal on the motor relay, and secure it with a lock washer and 5/16"-24 jam nut.
- Route cable without a stripe directly to the NEGATIVE battery terminal (carefully separate the two cables as needed to reach the battery ground connection). DO NOT reconnect the battery ground.
- Find a grill location on driver-side for the vehicle harness (similar position to battery cable mount). See Steps 8 & 9 above for how to install. Route vehicle harness through grill and around, or through radiator bulkhead (drill 5/8" hole if needed) into engine compartment.
- Route the wires that break out of the vehicle harness to the area behind the driver-side headlamp. Route rest of harness to the firewall. Drill a 5/8" hole through the firewall in a convenient location away from hot or moving engine parts.
- Feed vehicle harness fuse holder through hole and then feed the plastic connector and harness through to the cab. Disassembly of the fuse holder may make it easier to pass through 5/8" hole.
- Route brown/red and orange/black (early revision harnesses have brown/red and black/orange wires) wire loom to motor relay. Early revision harnesses must be modified if CabCommand hand-held control is being installed. (See instructions furnished with CabCommand control.)
- Attach the brown/red and orange/black (early revisions black/orange) wires small ring terminals to separate small terminals on motor relay using a lock washer and #10-32 nut for each connection.
- Route the 24" long orange/black wire with 3/8" ring terminal to battery negative post. Use a flat washer with small ground screws if required. (**DO NOT attach wire to battery at this time.**)
- Inside the cab, route vehicle harness connector to solenoid or CabCommand control and couple the connectors together.
- Reconnect vehicle ground cable to NEGATIVE battery terminal.

(Continued on next page)

UNDER HOOD INSTALLATION

VEHICLE HARNESS AND MOTOR RELAY - CONTINUED

21. Locate an accessory wire capable of carrying 6 amps in addition to existing circuit loads and controlled by the ignition (key) switch. Route the vehicle harness SFE-6 fuse holder red wire to this location and trim off any excess length of wire. (Keep fuse holder in system.) If used, DRL pink wire requires 0.4 amps.
22. Open blue self-stripping connector and place the end of the wire against the inner groove stop (end of wire must not extend from the closed connector), and the accessory wire in the outer groove. Close connector over the wires using a pliers and snap the locking tab in place.

OPTION: Locate an unused fuse box terminal operated by the ignition switch and attach a terminal (not furnished) to the red wire and plug into fuse box terminal.

23. Repeat with DRL wire.

⚠ CAUTION

Early style harnesses have a 10 amp fuse which must be replaced with a SFE-6 fuse for CabCommand control.

NOTE: Use dielectric grease to prevent corrosion on all under hood electrical connections. Fill receptacles and lightly coat ring terminals and blades before assembly.

DIELECTRIC GREASE P.N. 56099

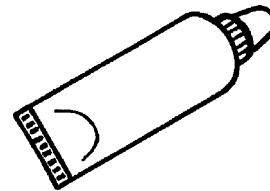

NOTE: A larger tube of dielectric grease is available. Part number #49326.

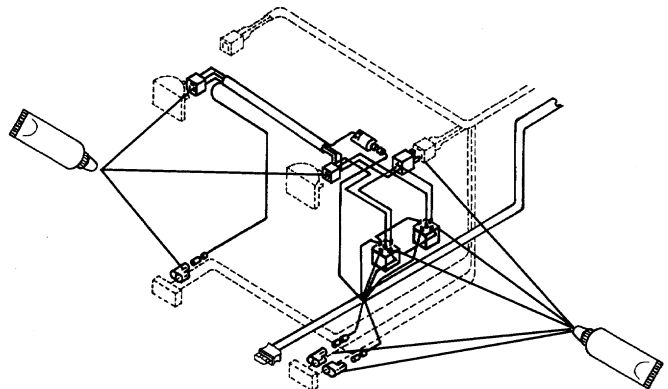
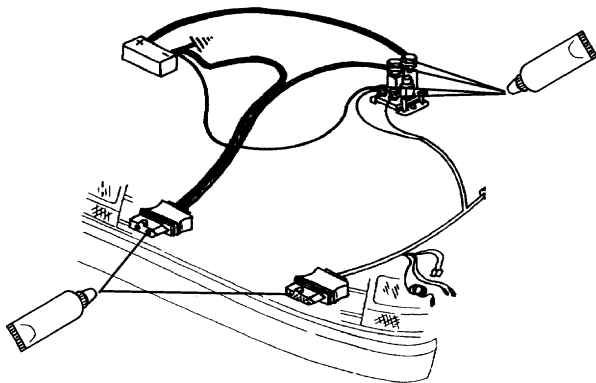

UNDER HOOD INSTALLATION

PLUG-IN HARNESS AND HEADLAMP RELAY INSTALLATION

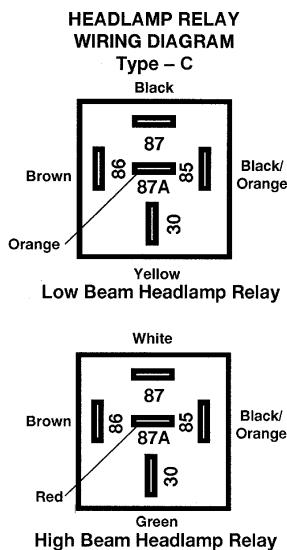

VEHICLE HEADLAMP WIRING DIAGRAM (TYPE C)

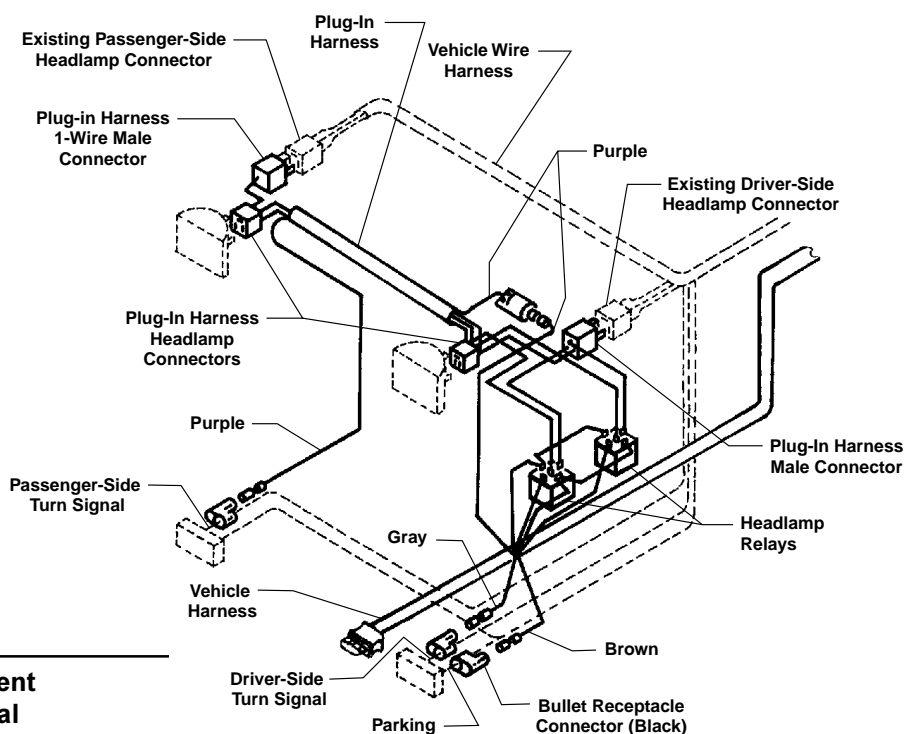

NOTE: Use dielectric grease to prevent corrosion on all under hood electrical connections. Fill receptacles and lightly coat ring terminals and blades before assembly.

1. In the engine compartment behind the driver-side headlamp, insert wire bullets from vehicle harness into black bullet connectors (installed in step one of previous section) as follows:
 - Brown wire to parking lamp wire on driver-side.
 - Gray wire to left turn signal wire on driver-side.
2. At the vehicle driver-side headlamp, remove the connector from the headlamp and couple with plug-in harness 3-wire male plug (plug-in harness found in harness kit). Attach plug-in harness headlamp connector to headlamp terminals.
3. Route other end of plug-in harness along radiator bulkhead or over radiator shroud to passenger-side headlamp. Remove headlamp connector and couple connector with plug-in harness 1-wire male plug. Attach plug-in harness headlamp connector to headlamp terminals.
4. On the passenger-side, insert purple wire bullet from plug-in harness into vehicle turn signal black bullet connector installed in step one of the previous section.
5. At the driver-side headlamp, insert the purple wire bullet from the vehicle harness into the purple wire receptacle on the plug-in harness.
6. At driver-side headlamp, connect vehicle and plug-in harness wires with receptacles to the two headlamp relays (found in harness kit) as shown in the above diagram. (If vehicle has DRLs, replace brown wires with pink wire from DRL kit. Brown wires from vehicle harness are not used in DRL installations.)
7. Place grommet around vehicle harness and insert into firewall hole (also put a grommet in the radiator bulkhead hole if one was drilled). Use cable ties (found in harness kit) to secure harnesses, relays and wires away from sharp edges, and hot or moving engine parts and to prevent accidental grounding of connections.
8. Lubricate terminal cavities of both harness connectors with dielectric grease. **Give the dielectric grease tube to vehicle owner for future use.**

OPERATIONAL TESTS AND ADJUSTMENTS

FILLING HYDRAULIC UNIT

NOTE: Mount plow assembly to vehicle. (See label on back of blade or Owner's Manual for mounting instructions.)

⚠ CAUTION

Remove fluid level plug slowly to allow any residual pressure in the reservoir to bleed off.

1. Push lift channel all the way down.
2. Remove fluid level plug and fill plug.

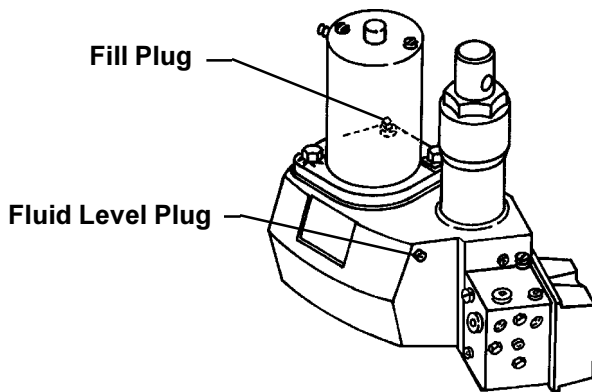

3. Fill unit through fill plug hole until fluid runs out of fluid level plug hole.

USE

- Automatic transmission fluid (ATF) Dexron III to -10° F (-23° C),
- WESTERN® High Performance Fluid to -25° F (-32° C),
- Texaco 1537 Aircraft Hydraulic Oil for temperatures below -25° F (-32° C).

4. Replace both plugs.
5. Turn ignition (key) switch to the ON or ACCESSORY position.
6. Turn the control ON/OFF switch to the ON position.
7. Move control lever to angle left and angle right several times to remove air from Hydra-Turn® rams.

⚠ CAUTION

DO NOT raise blade as this may cause pump cavitation.

8. Refill unit with fluid following the procedure in steps 1- 4 of this section.
9. Move the control lever as indicated on label to control the plow. Raise and lower plow several times to remove air. Place control lever in float position. Push lift channel all the way down. Recheck fluid level according to steps 1- 4 of this section.

FLUID CAPACITY

Solenoid ISARMATIC® Mark IIIa reservoir 1-3/4 quarts

Equipped with 10" Hydra-Turn® rams 2-3/8 quarts

⚠ WARNING

WARNING: To prevent accidental movement of plow, always turn the solenoid control to the OFF position when not using the mounted plow.

OPERATIONAL TESTS AND ADJUSTMENTS

BLADE DROP SPEED ADJUSTMENT

NOTE: The quill on the top rear of the valve manifold (see diagram) adjusts blade drop speed. Turning quill too far in can slow raise time and cause battery drain.

- Turn quill IN (clockwise) to decrease drop speed.
- Turn quill OUT (counterclockwise) to increase drop speed.

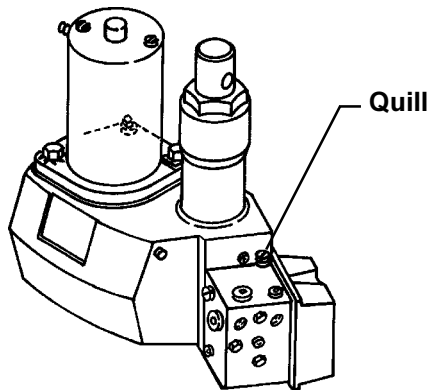

COUPLING LUG HEIGHT CHECK

1. Mount plow to vehicle. (See label on back of blade or Owners Manual for mounting instructions.) Add recommended ballast as found in selection list.
2. With the blade on a level surface, slack in lift chain and rear ballast located behind rear wheels, the center of the coupling holes (hitch pin shaft) to level surface should measure 9-1/2" to 10-1/2". To obtain height, adjust spreader position. Both coupling lugs and link arms may be turned over to change height 1"
3. Adjust air pressure in air shocks (MOPAR kit #82202562) to obtain this height.

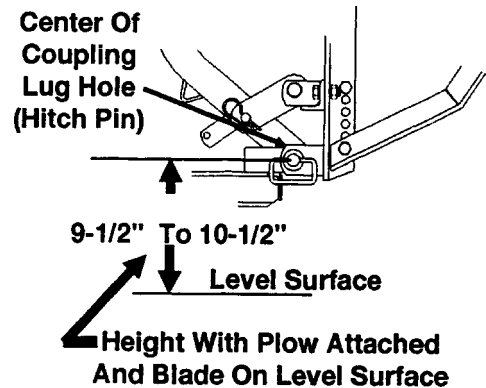

FINAL INSPECTION

1. Make sure all fasteners and hydraulic and electrical connections are tight.
2. Check ram packing nuts for oil leakage. If excessive leakage is observed, tighten the packing nut 1/4 turn after you feel the nut contact the packing.

NOTE: Do not over tighten packing nuts. Over tightening affects cylinder operation and shortens the life of the packing. A short period of normal operation will allow chevron packings to become saturated, and leakage will normally stop. A small amount of leakage is necessary to properly lubricate the cylinder rod.

NOTE: Coupling height must be 9-1/2" minimum to allow stand to be pinned to frame.

4. Adjust chain slack with plow mounted to vehicle and lift channel pushed all the way down. To adjust, remove chain from hook, straighten chain and pull tight. Rehook it to the lift channel. After chain is hooked, it will have the correct amount of slack for blade "float". DO NOT remove chain from lift channel when removing plow from vehicle.

OPERATIONAL TESTS AND ADJUSTMENTS

VEHICLE LIGHTING CHECK

1. Check the operation of vehicle and plow lights with plow mounted to vehicle and all harnesses connected.

Turn signals and parking lamps

Parking lamps ON
Right turn signal ON
Left turn signal ON

Both vehicle and plow parking lamps should be on at the same time.
Both vehicle and plow right turn signal lamps should flash at the same time.
Both vehicle and plow left turn signal lamps should flash at the same time.

Headlamps

Move vehicle headlamp switch to the ON position. Connecting and disconnecting the 9-pin plow plug from the vehicle harness connector should switch between vehicle and plow headlamps as follows:

9-pin plow plug DISCONNECTED Vehicle headlamps should be on, plow headlamps off.
9-pin plow plug CONNECTED Plow headlamps should be on, vehicle headlamps off.

Dimmer switch should dim whichever headlamps are operating. The high beam indicator on the dash should light when either set of headlamps is on high beam.

Solenoid Control or CabCommand Control

9-pin vehicle harness revision 10 and later or
9-pin vehicle harnesses earlier revisions modified for CabCommand Control:

The control indicator light should light whenever the control ON/OFF switch and the ignition (key) switches are both turned ON. The plow plugs do not need to be connected to the vehicle harness connectors.

2. Connect plow plug to vehicle harness connector. Raise plow and aim plow headlamps according to SAE J599 Lighting Inspection Code (**See Service Bulletin SP 608**). **Add additional lighting required by state or local regulations.**
3. Check aim of vehicle headlamps with plow removed.
4. When plow is removed from the vehicle, install plug covers on vehicle harness connectors and insert the plow plugs into the boot on the hydraulic unit.

(Continued on next page)

WIRING DIAGRAM

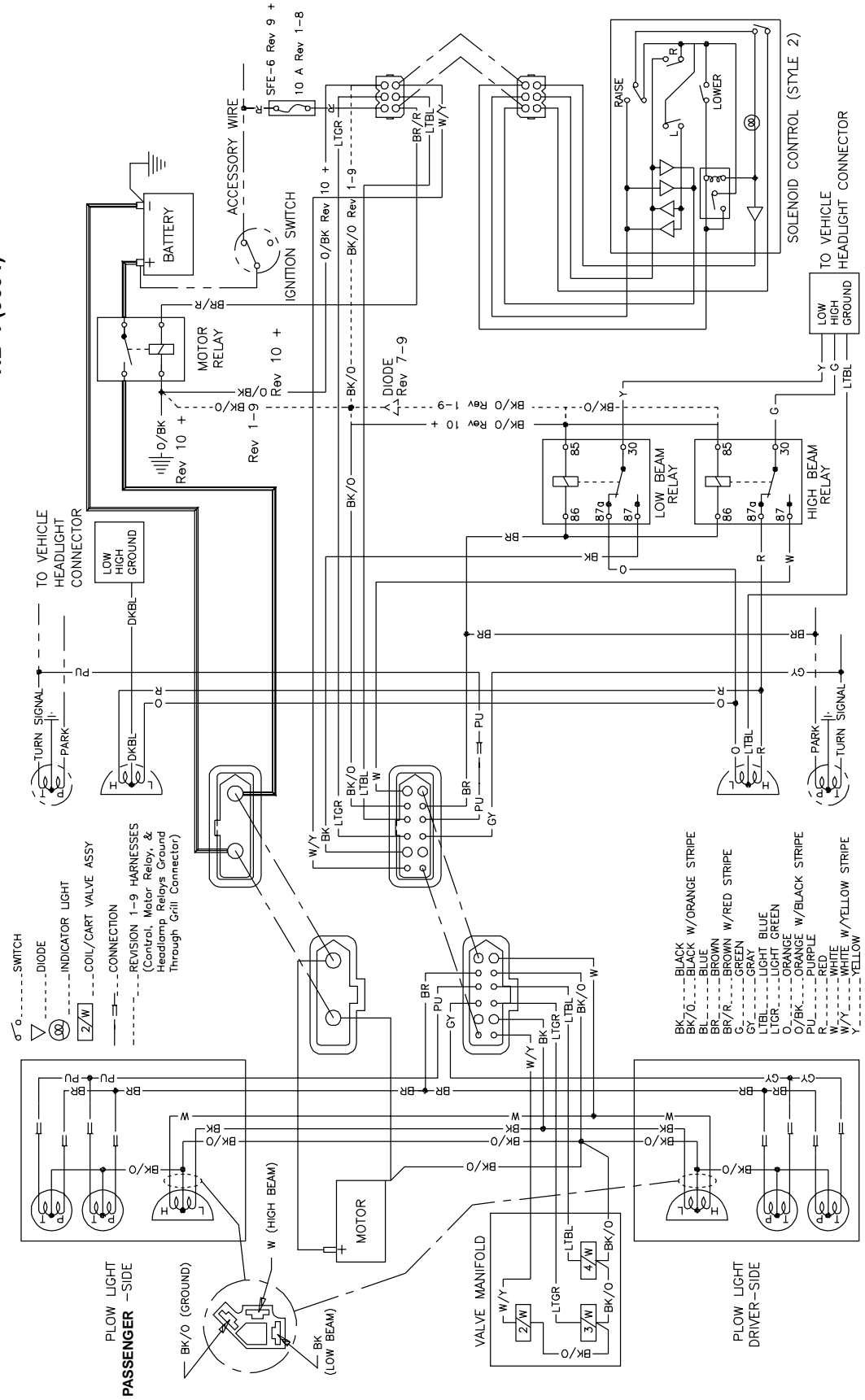



WESTERN PRODUCTS
P.O. BOX 23045
7777 N. 73RD STREET
MILWAUKEE, WI 53223-0045



A DIVISION OF DOUGLAS DYNAMICS, L.L.C.

Western Products reserves the right under its Product Improvement Policy to change construction or design details and furnish equipment when so altered without reference to illustrations or specifications used herein. Western Products and the vehicle manufacturer may require and/or recommend optional equipment for snow removal. Western Products offers a limited warranty for all snowplows and accessories. See separately printed page for this important information. The following are registered® trademarks of Douglas Dynamics, L.L.C.: WESTERN®, ISARMATIC® and Hydra-Turn®.