

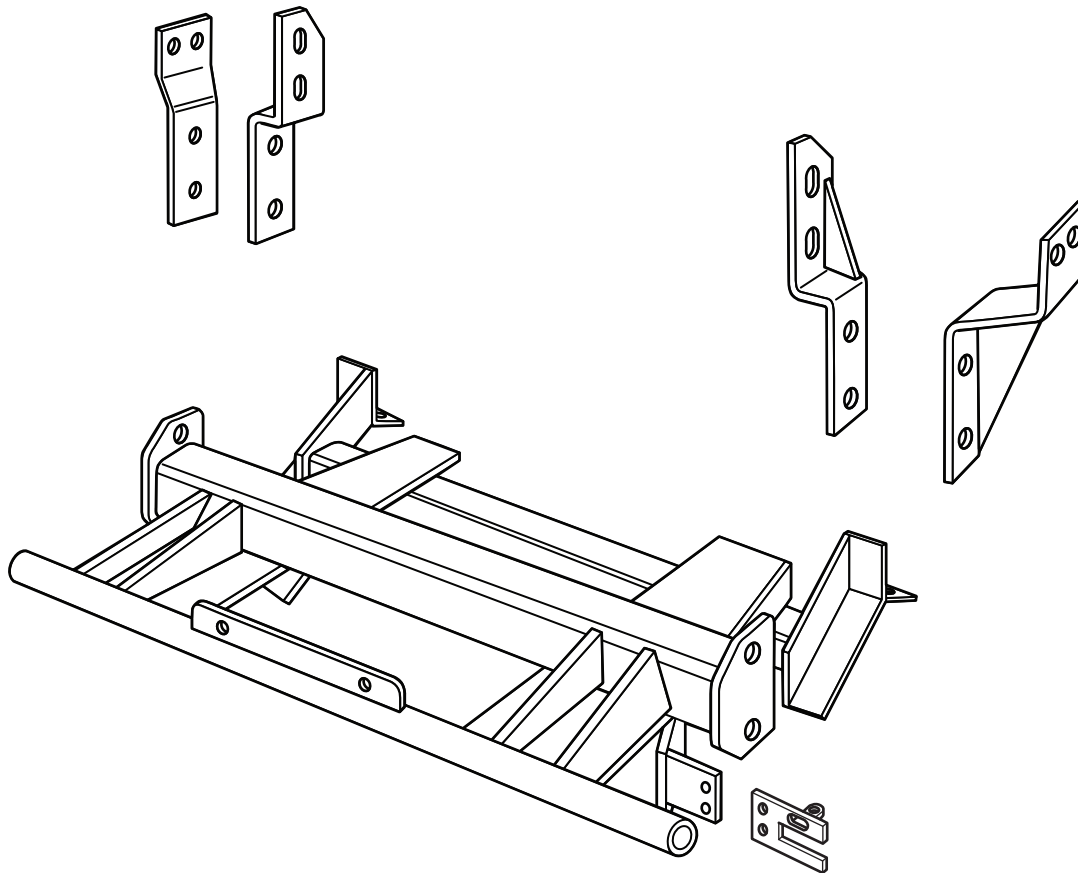

HOME-PRO® 3000

**1998 - 1999 Dakota Durango
(With Max. FGAWR. & Max. GVWR. ONLY)**

Vehicle Mounting Kit: 1FK13



Curtis Industries Inc. LLC, 111 Higgins St., Worcester, MA 01606 TEL: (800) 343-7676 FAX: (508) 854-3377 For Parts and information visit us at www.Curtisindustries.net
Curtis Industries Inc. LLC, reserves the right to change product design or specifications without notice or liability.
Curtis Snow Plows are protected by the following U.S. Patent Numbers: 6,145,222 and 6,209,231 Licensed under U.S. Patent Number 5,568,694 & Canadian Patent Number 2,137,853.
Other patents pending.

1FK13 Vehicle Mount Kit Parts List

Item #	Description	Qty.
1	Driver's Side Inner Front Hanger	1
2	Passenger's Side Inner Front Hanger	1
3	Driver's Side Outer Front Hanger	1
4	Passenger's Side Outer Front Hanger	1
5	Mounting Frame	1
Hardware Bag Components Included In This Kit		
6	1/4"-20 x 3/4" Hex Bolt, Gr. 5, Plated	2
7	12mm x 1.75mm x 40mm Hex Bolt, Gr.10.9, Plated	4
8	1/2"-13 x 1-1/2" Hex Bolt, Gr. 5, Plated	4
9	5/8"-11 x 1-1/2" Hex Bolt, Gr. 5, Plated	2
10	1/4" Flat Washer, Plated	2
11	5/8" Flat Washer, Plated	2
12	1/4" Lock Washer, Plated	2
13	12mm Lock Washer, Plated	4
14	1/2" Lock Washer, Plated	4
15	5/8" Lock Washer, Plated	2
16	1/4"-20 Hex Nut, Gr. 5, Plated	2
17	1/2"-13 Hex Nut, Plated	4
18	5/8"-11 Hex Nut, Plated	2
Hardware Components Included In Plow Light Harness Kit		
5a	Plug Mount Bracket	1
-	10-32 x 3/4" Hex Head Screw, Plated	2
-	10-32 Nylock Lock Nut, Plated	2
-	8-32 x 1" Hex Head Screw, Plated	1
-	8-32 Nylock Lock Nut, Plated	1
-	#8 Nylon Flat Washer, 3/4" O.D.	1
-	#8 Flat Washer, SAE, Plated	1



WARNING

It is highly recommended that front "helper springs", "airshocks", or other similar devices be installed onto this vehicle to prevent the front suspension from "bottoming out" while carrying a snow plow.

Vehicle must be properly "ballasted" by placing ballast weight behind the centerline of Rear Axle so that no more than 62% of the total weight of the Vehicle, Snow Plow, Driver, Ballast weight, (and any cargo) is placed on the Front Axle while at the same time not exceeding the Gross Vehicle Weight Rating and Front or Rear Gross Axle Weight Ratings.

1FK13 Mounting

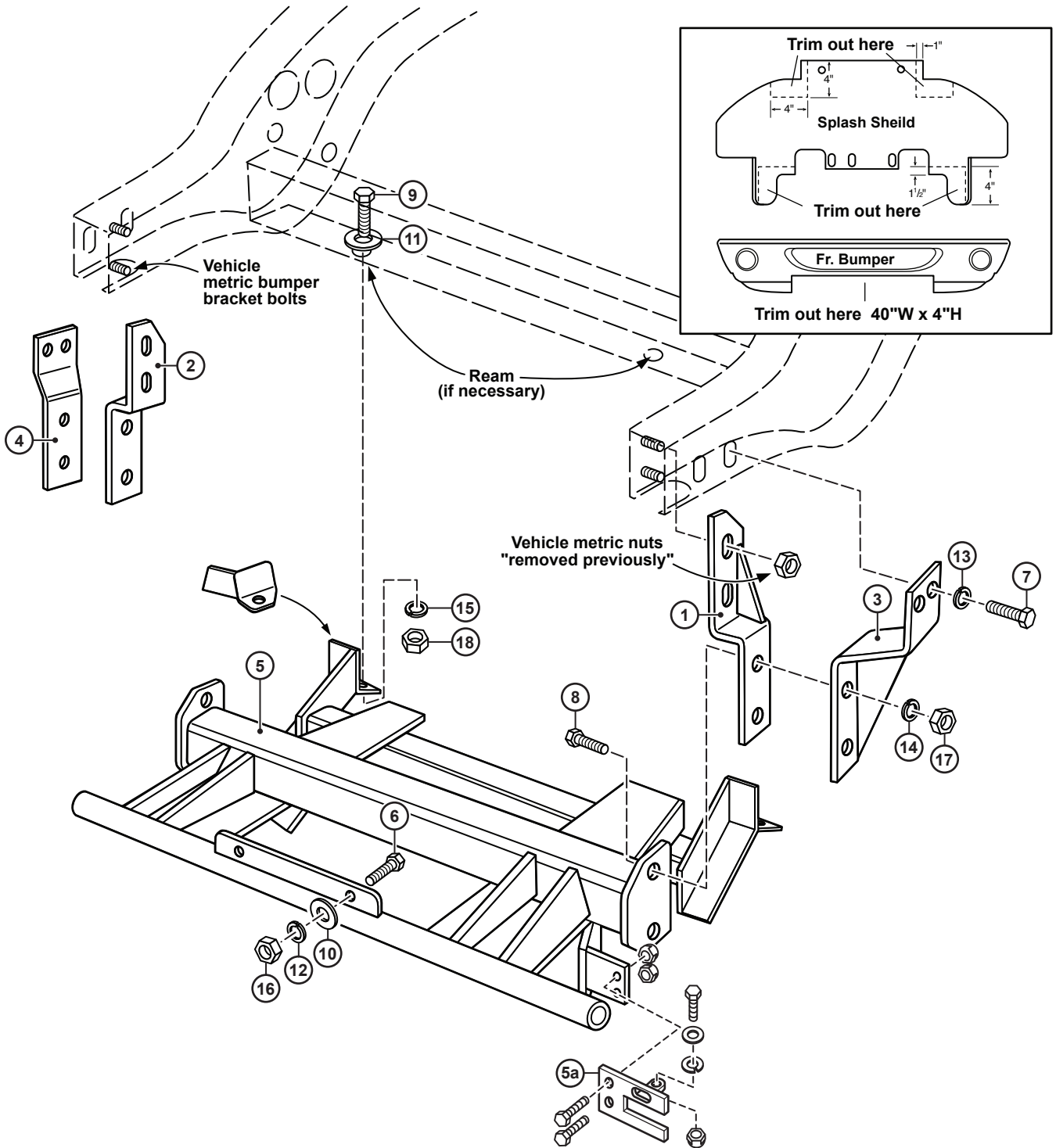

Curtis Industries, LLC. reserves the right to change product design or specifications without notice or liability. Curtis Snow Plows and Truck equipment should only be used on vehicles equipped with the manufacturer's Snow Plow preparation package. Snow Plowing without the original snow plow preparation package may damage your vehicle and the added weight of the equipment may impair the operation and control of the vehicle.

1FK13: 1998 - 1999 Dakota Durango

Mounting Kit Installation Instructions

1. VEHICLE PREPARATION

Temporarily remove the plastic splash shield, (just behind the front bumper) and the vehicle front bumper. Save the original equipment vertical metric bumper bolts, (for later reinstallation). Discard the horizontal metric mounting bolts holding the bumper to it's mounting brackets and the vehicle frame. Remove and save, (for later reinstallation) the metric nuts holding the bumper mounting brackets to the frame rails. Trim the plastic splash shield and the lower plastic portion of the front bumper as shown in the enclosed illustration.



NOTE

All fasteners should remain loose or "finger tight" until all components have been attached to vehicle or installation instructions specify tightening.

2. INNER FRONT HANGERS

- (2a.) Install the Inner Front Hangers (1 & 2) on over the ends of the metric bolts holding the front bumper brackets to the inner surface of the frame rails. Fasten loosely using the metric nuts removed previously.
- (2b.) Place the trimmed plastic splash shield loosely back into position. However, do not fasten completely.

3. MOUNTING FRAME

- (3a.) Lift the Mounting Frame (5) up under the front of the vehicle with the end plates on the front cross tube between the Inner Front Hangers (1 & 2). Line up the holes in the inner front hangers with the holes in the end plates. Insert 1/2"-13 x 1-1/2" Bolts (8) into the holes from the inside of the inner front hangers to the outside of the end plates.
- (3b.) Place the trimmed front bumper back into position and fasten it loosely to the bumper mounting brackets using the original equipment metric bolts removed previously.

4. OUTER FRONT HANGERS

- (4a.) Install the lower ends of the Outer Front Hangers (3 & 4) on over the ends of the 1/2"-13 x 1-1/2" Bolts (8) holding the end plates on the front cross tube of the mounting frame (5) to the inner front hangers (1 & 2). Fasten loosely using 1/2" Lock Washers (14), and 1/2"-13 Nuts (17).
- (4b.) Line up the holes in the upper end of outer frame hangers with the holes in the front bumper rear mounting brackets and the tapped tab nuts in the frame rails. Fasten loosely using 12mm x 1.75mm x 40mm Bolts (7), and 12mm Lock Washers (13).

5. DRILLING & TIGHTENING

- (5a.) Line up the holes in the rear bolting ears of the Mounting Frame (5) with the holes in the vehicle front cross member. If necessary, ream through the two sets of holes using an 11/16" dia. drill. Fasten using 5/8"-11 x 1-1/2" Bolts (9), 5/8" Flat Washers (11), 5/8" Lock Washers (15), and 5/8"-11 Nuts (18). (The heads of the bolts and the flat washers should be inside the cross member).
- (5b.) Align the front bumper with the vehicle grill and body work, then tighten all bumper bracket, mounting frame, and front hanger fasteners.
- (5c.) Fasten the trimmed plastic splash shield into place using the original equipment plastic fasteners. If necessary, attach the vehicle front license plate to the bracket provided on the cross bar of Mounting Frame (5) using 1/4"-20 x 3/4" Bolts (6), 1/4" Flat Washers (10), 1/4" Lock Washers (12), and 1/4"-20 Nuts (16).

6. FINAL ADJUSTMENT AND INSPECTION

Inspect the front mounting, front hanger, and bumper bracket attachment bolts to be certain that they are all in place and that they are all tight.

7. OPTIONAL PLUG MOUNT BRACKET INSTALL



NOTE

Install the Plug Mount Bracket if the harness will be mounted on the frame kit, otherwise, the harness may be routed through the grill, bumper, etc.

Using (2) 10-32 x 3/4" hex bolts and nylon locknuts, fasten the Plug Mount Bracket to the Plug Mount Bracket Mounting Tab located on the driver's side of the frame kit receiver. The included 8-32 hardware is used for mounting the hi-amp battery leads to the Plug Mount Bracket if used.

