

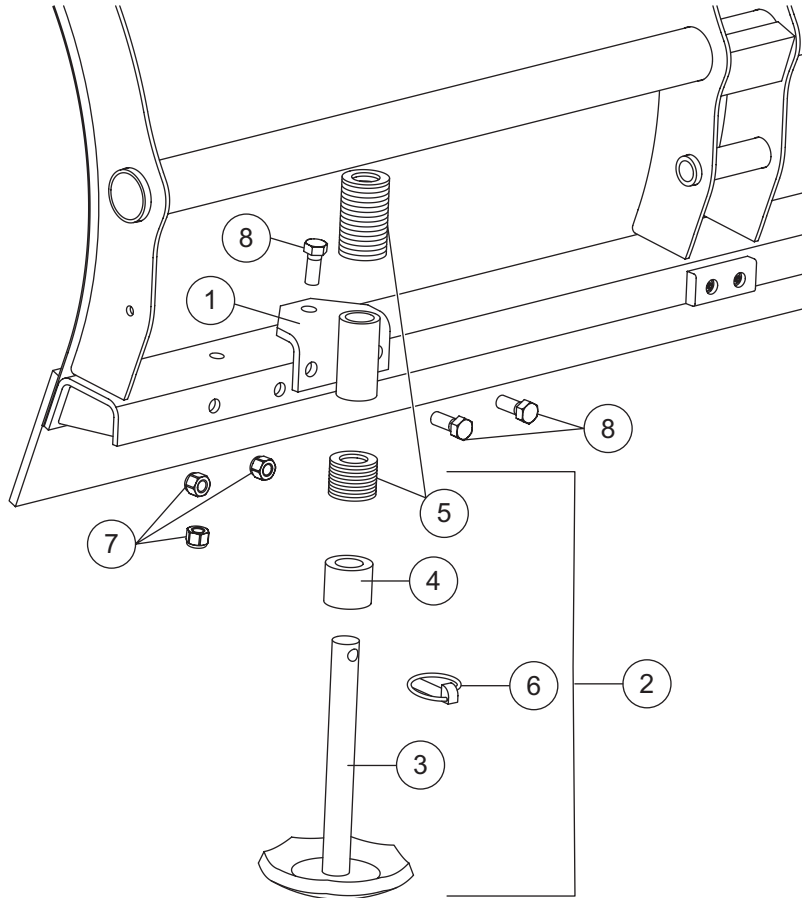

64392
SHOE ASSEMBLY KIT
UltraMount® MidWeight™ Blade
Parts List and
Installation Instructions

WESTERN PRODUCTS, P.O. BOX 245038, MILWAUKEE, WI 53224-9538

A DIVISION OF DOUGLAS DYNAMICS, L.L.C.



64392 SHOE ASSEMBLY KIT (PAIR)			
Item	Part	Qty	Description
1	64388	2	SHOE BRACKET
2	49067	2	DISC SHOE ASSEMBLY
3	60028	2	DISC SHOE
4	60045	2	SPACER
5	91192	52	ROUND FLAT WASHER – SPECIAL
6	93010	2	7/16 x 1-3/4 LINCH PIN ZYC
NS	64391	1	BOLT BAG ASSEMBLY (64392)
64391 BOLT BAG ASSEMBLY (64392)			
7	91335	6	1/2-13 HEX LOCKNUT GB
8	90575	6	1/2-13 x 1-1/4 HEX CAP SCREW G5
G = Grade		NS = Not Shown	
ZYC = Zinc Yellow Chromate			

64392 SHOE ASSEMBLY KIT INSTALLATION INSTRUCTIONS

INSTALLATION INSTRUCTIONS

⚠ WARNING

Raise and securely support blade with blocks or tip blade face down for installation.

NOTE: Please give these instructions to the customer.

1. Position the shoe bracket to the blade base channel as shown in Figure 1. Align holes in shoe bracket with holes in base channel.
2. Loosely assemble each shoe bracket with two 1/2" x 1-1/4" hex cap screws and 1/2" hex locknuts through back of bracket and base channel, and one 1/2" x 1-1/4" hex cap screw and 1/2" hex locknut through the top hole in bracket and base channel. Torque fasteners to 75 ft-lbs. (See Figure 1.)

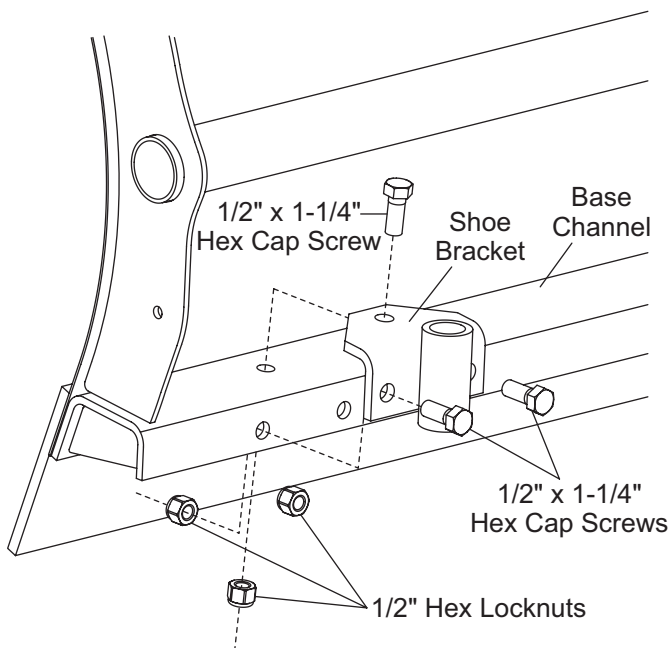

DISC SHOE ADJUSTMENT

Changing the number of washers above or below the shoe bracket adjusts cutting edge height and pressure.

Adjust disc shoes by placing spacer and 10 washers on bottom of shoe bracket and 16 washers on top. Final adjustment is made with plow attached to vehicle. (See Figure 2.)

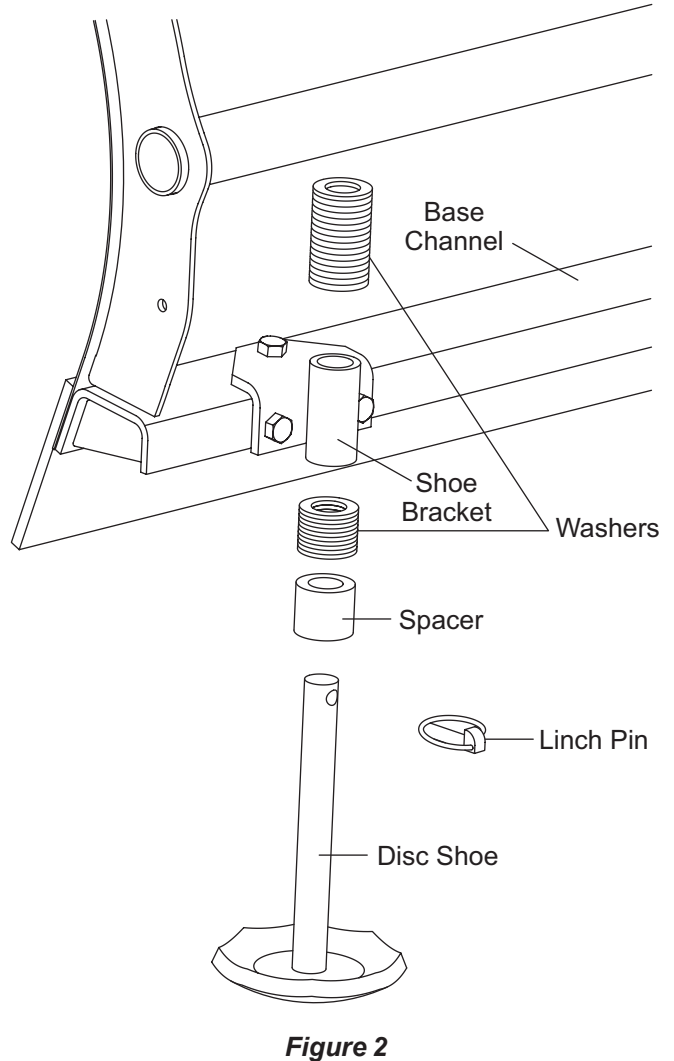

Copyright© 2004 Douglas Dynamics, L.L.C. All rights reserved. This material may not be reproduced or copied, in whole or in part, in any printed, mechanical, electronic, film or other distribution and storage media, without the written consent of Western Products. Authorization to photocopy items for internal or personal use by Western Products outlets or snowplow owner is granted.

Western Products reserves the right under its product improvement policy to change construction or design details and furnish equipment when so altered without reference to illustrations or specifications used. Western Products and the vehicle manufacturer may require and/or recommend optional equipment for snow removal. Do not exceed vehicle ratings with a snowplow. Western Products offers a limited warranty for all snowplows and accessories. See separately printed page for this important information. The following are registered (®) trademarks of Douglas Dynamics, L.L.C: UltraMount® and WESTERN®.

Printed in U.S.A.