



PARTS & INSTALLATION INSTRUCTIONS

MEYER SNOW PLOW MOUNTING

1993 HUMMER® 4x4 VEHICLE (Civilian)

IMPORTANT NOTICE

End user must be given this information prior to delivery of this Snow Plow.

The equipment you have just purchased should only be used on vehicles equipped with the Manufacturer's Snow Plow Preparation Packages. Snow Plowing without the original Snow Plow Preparation Package may damage your vehicle and the added weight to the equipment may impair the operation and control of the vehicle. Snow plowing with a vehicle that the manufacturer does not recommend for that purpose may void your new vehicle warranty. If your vehicle is not originally equipped with the Snow Plow Preparation Package, additional parts may be necessary before snow plowing. Owners of these vehicles should consult their dealers before purchase or installation of such parts. CAUTION: The installation, on any vehicle, of these parts is not a full substitute for the original equipment Snow Plow Preparation Package.

WARNING: Lift Arm extends beyond bumper of vehicle. To minimize damage from a front-end collision, Lift Arm should be removed from vehicle when Snow Plow is removed.

PARTS LIST

OBSOLETE PARTS ONLY

Item	Part No.	Qty.	Description
1	17101	1	MOUNTING CARTON
	11450	1	• Clevis Frame
	11451	1	• L.H. Support Brace
	11452	1	• R.H. Support Brace
	10514	1	• Lift Arm
	11463	2	• Receiver Tube Cap
6	11315	2	• Lift Frame Stops
7	08647	1	• HARDWARE BAG
	11449	2	•• Spacer
	20025	1	•• Bolt H 5/16 - 18 x 3/4" Gr. 2
	20105	2	•• Bolt H 1/2 - 13 x 4" Gr. 5
	20140	2	•• Bolt H 5/8 - 11 x 1 3/4" Gr. 5
	20144	1	•• Bolt H 5/8 - 11 x 2 3/4" Gr. 5
	20146	2	•• Bolt H 5/8 - 11 x 3 1/4" Gr. 5
	20150	6	•• Bolt H 5/8 - 11 x 4 1/2" Gr. 5
	20307	2	•• Locknut 1/2 - 13
	20309	11	•• Locknut 5/8 - 11
	20313	1	•• Locknut 5/16
	20355	2	•• Flatwasher 1/2"
	21400	1	•• Lockwasher 5/16"
	05024	1	•• Cable (black)
	11006	2	•• Hinge Pin
21984	2	•• Hair Pin Cotter	
22	11255	1	LIFT FRAME (Tubular)
15" Sector			
Item	Part No.	Qty.	Description
23	16504	1	SECTOR & A-FRAME CARTON
	12793	1	• Sector
	13608	1	• A-Frame
	07017	4	• Trip Spring
	09916	1	• Snow Plow Markers
24	08341	1	• PLOW HARDWARE BAG
	09119	2	•• Pivot Pin W/Cotter Pin
	11101	2	•• Hinge Pin
	22083	2	•• Linch Pin
	09125	1	•• King Bolt W/Locknut
	09124	4	•• Eye Bolt W/Locknuts

Parts indented are included in the carton, bag or assembly under which they are indented.

When ordering parts, furnish Part No., Name, and Description. Also furnish Vehicle Model and Year, Type of Hydraulic Unit and Moldboard size.

HUMMER® is a Registered Trademark of AM General Corporation.

Meyer Products reserves the right, under its continuing product improvement program, to change construction or design details, specifications and prices without notice or without incurring any obligation.

GENERAL INFORMATION

CAUTION: Always disconnect battery before beginning installation.

DO NOT burn holes or weld vehicle frame. This may cause frame failure.

After first use, retighten all mounting bolt connections to specified torque. All mounting bolt connections to be checked periodically for tightness.

Locknuts are furnished. **DO NOT** tighten bolts and nuts until installation is complete (unless otherwise specified), then be sure to tighten all attaching parts per specified torque chart.

NOTE: It is important that the Meyer harness, all wires from the Meyer light switch, and all other electrical wires be routed around hot or moving engine parts, and any sharp sheet metal. Protection must be provided to guard against wire damage at these points. All excess or loose wires must be neatly secured using wire ties.

Check contents against the parts list to determine all are correct and included. When ordering parts, furnish Part No., Name and Description, Type of Hydraulic Unit and Moldboard Size.

SAFETY PRECAUTIONS should be used when **ELECTRO TOUCH™** is in **OPERATION** and plow is in a **RAISED** position. **Lower plow to ground when vehicle is PARKED.**

OVERHAUL and **SERVICE INFORMATION** are covered on separate Instructions.

IMPORTANT: In order for this vehicle to be equipped with a snow plow, it will be necessary to remove the (954) front springs and replace them with a heavier spring part number 1728. Contact your Hummer Dealer for further information.

Follow These instructions explicitly. Warranty does not apply to a Meyer product which has been negligently or improperly assembled or installed.

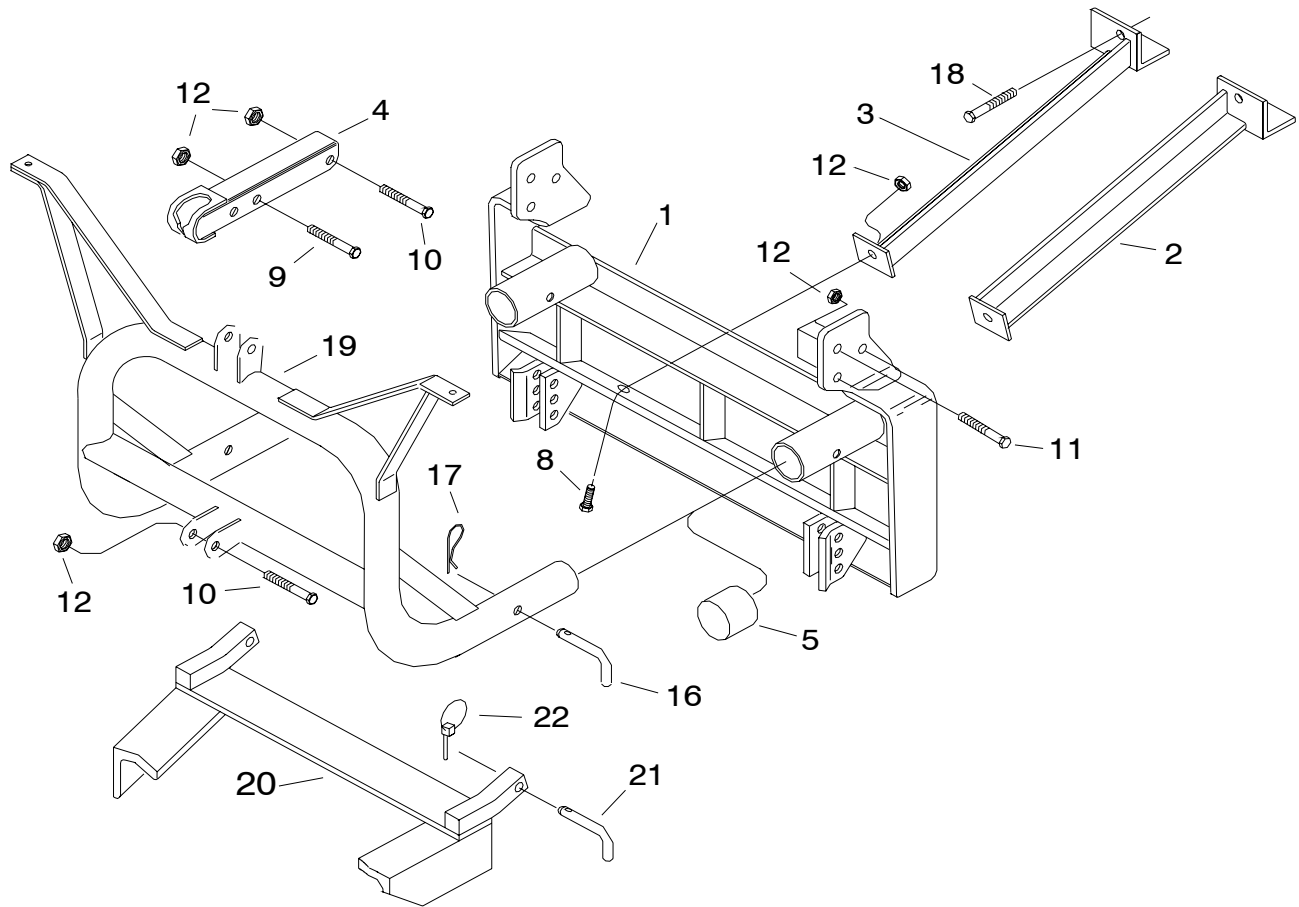

INSTALLATION INSTRUCTIONS:

- A. Remove front bumper at lifting shackle. Retain hardware for reuse.
- B. Remove three bolts thru bumper bracket and frame at each side. These bolts will not be reused.
- C. Loosen bolt at suspension crossmember and rotate strap toward center of vehicle.
- D. Locate Clevis Frame in position and attach to vehicle frame using 5/8 - 11 x 4-1/2" bolt (13) and locknuts (15).
- E. Attach braces to Clevis Frame using 5/8 - 11 x 1-3/4" bolt (10) and Locknuts (15).
- F. Using braces as templates, mark and drill two 17/32 diameter holes thru both flanges of crossmember. Holes must be in line.

- G. Attach braces to crossmembers using spacers (7) between flanges, 1/2 - 13 x 4" bolts (9), Flatwashers (17) and Locknuts (14).
- H. Push Clevis Frame (1) toward back of vehicle to take out the slack in the bolts.
- I. Start at front of vehicle, tighten all bolts to proper torque.
- J. Re-attach bumper using existing hardware.

Note: Before installing lift frame (22) tubing to clevis frame, remove paint from ends of lift frame and inside of clevis frame receiver tubes. Liberally coat ends of lift frame with chassis grease/anti-seize lubricant.

- K. Install Lift Frame (22) into Clevis Frame (1) and attach using Hinge Pins (20) and Hair Pin Cotter (21). Remove stops (Part #10626) from lift frame per illustration.
- L. Attach Lift Arm (4) to lift frame (22) using 5/8 x 3-1/4" bolt (12) and locknut (15). Mount Hydraulic unit to lift frame with 5/8 x 3-1/4" Bolt (12) and locknut (15), and to lift arm (4) using 5/8 x 2-3/4" bolt (11) and locknut (15).
- M. Install hydraulic system and snow plow lights per separate instructions except as listed below.

1. Attach ground cable (Part #15672) to alternator bracket in place of battery. Be certain contact area is clean. Extend the length of this cable by attaching cable (19) using 5/16 - 18 x 3/4" Bolt (8), external tooth lockwasher (18) (between the cable terminals) and Locknut (16). Completely insulate the connection with Electrical tape.

2. Attach Power Cable Part #05024 to + (positive) side of starter in place of battery.

- N. Pre-assemble moldboard, A-frame, and Sector per separate instructions.
- O. Connect A-frame to clevis frame using hinge pins (24) and Linch Pin (25).
- P. Hook the A-frame chain to lift arm allowing sufficient slack to enable moldboard to follow ground contour while plowing. **Warning:** Lift Arm extends beyond bumper of vehicle. To minimize damage from a front-end collision, Lift Arm should be removed from vehicle when Snow Plow is removed.

Note: When lift frame module (22) is removed from the vehicle, the insides of the clevis frame (1) receiver tubes and outside ends of the lift frame should be coated with chassis grease / anti-seize lubricant and the protective receiver tube caps (5) installed over the clevis frame receiver tubes.

Meyer Products assumes no responsibility for installations not made in accordance with these instructions.

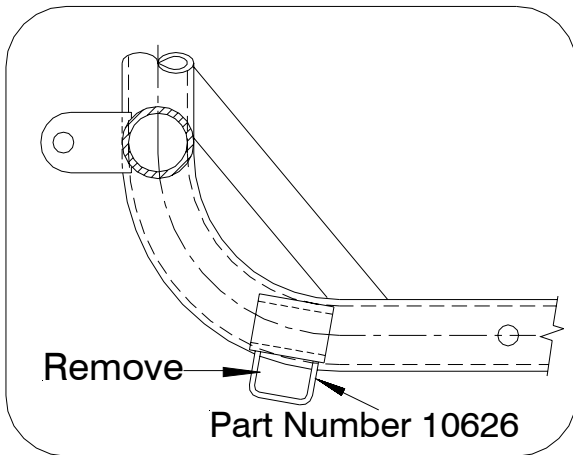

TORQUE CHART FOOT LBS.

Bolt-Nut Size	GR. 2	GR. 5	GR. 8
1/4 - 20	4 - 5		
5/16 - 18	9 - 11		
3/8 - 16	17 - 20	26 - 29	60 - 66
7/16 - 14		42 - 46	90 - 100
1/2 - 13		64 - 72	179 - 198
5/8 - 11		127 - 141	
3/4 - 10		227 - 251	