

# 27550

## OFF TRUCK COMPONENTS PERSONAL PLOW

### Installation Instructions

**⚠ CAUTION**

Read this document before installing the snowplow.

**⚠ CAUTION**

See your sales outlet for specific vehicle application recommendations before installation. The Kit Selection Guide/Selection List has specific vehicle and snowplow requirements.

**SAFETY DEFINITIONS**

**⚠ WARNING**

Indicates a potentially hazardous situation that, if not avoided, could result in death or serious personal injury.

**⚠ CAUTION**

Indicates a potentially hazardous situation that, if not avoided, may result in minor or moderate injury. It may also be used to alert against unsafe practices.

**NOTE:** Indicates a situation or action that can lead to damage to your snowplow and vehicle or other property. Other useful information can also be described.

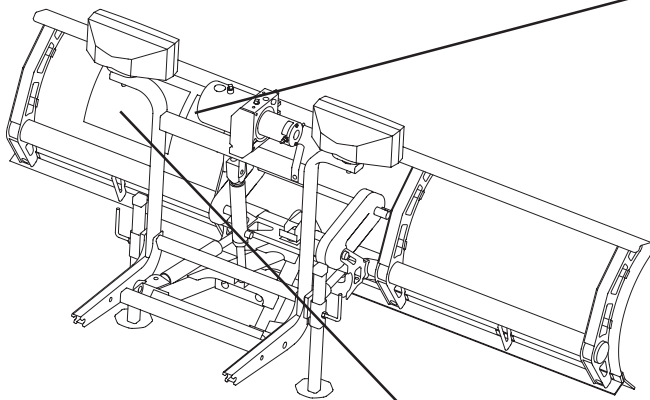

**WARNING/CAUTION AND INSTRUCTION LABELS**

Become familiar with and inform users about the warning label and instruction label on the back of the blade.

**NOTE:** If labels are missing or cannot be read, see your sales outlet.

**Warning/Caution Label**

**⚠ WARNING**

LOWER BLADE WHEN VEHICLE IS PARKED.

REMOVE BLADE ASSEMBLY BEFORE PLACING VEHICLE ON HOIST.

DO NOT EXCEED GVWR OR GAWR INCLUDING BLADE AND BALLAST.

**⚠ CAUTION**

READ OWNER'S MANUAL BEFORE OPERATING OR SERVICING SNOWPLOW.

TRANSPORT SPEED SHOULD NOT EXCEED 45 MPH. REDUCE SPEED UNDER ADVERSE TRAVEL CONDITIONS.

PLOWING SPEED SHOULD NOT EXCEED 10 MPH.

SEE YOUR SALES OUTLET FOR APPLICATION RECOMMENDATIONS.

**Instruction Label**

***This snowplow is for personal/homeowner use only.***

- ATTACH INSTRUCTIONS**
1. Make certain both **connecting pins** are fully retracted.
  2. Drive vehicle slowly to completely insert **attachment arms** into **receiver assembly** slots.
  3. Twist both **connecting pins** to release spring tension, then push **plow gear** toward vehicle so **connecting pins** fully engage holes in **attachment arms**.
  4. Loosen one **jack handle** and slide **jack sleeve** down below **jack retainer**. Remove **jack** and retighten **jack handle**. Repeat for other **jack** and store them.
  5. Connect all electrical cables from vehicle to snowplow.

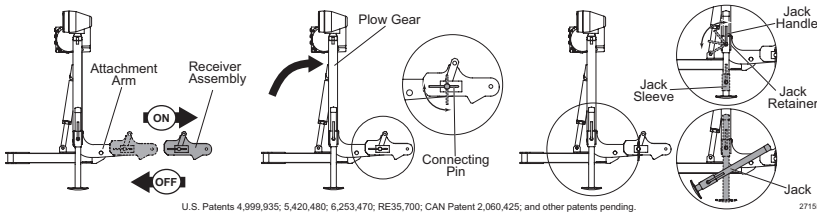

- DETACH INSTRUCTIONS**
5. Back vehicle away from snowplow.
  6. See Owner's Manual for proper snowplow storage.
  3. While pushing **plow gear** toward vehicle to release **connecting pin** tension, pull **connecting pin** out on one side and twist pin handle to keep pin retracted. Repeat procedure for other **connecting pin**.
  4. Disconnect all electrical cables.
  1. Put blade on ground using **LOWER/FLOAT** on snowplow control. Leave control **ON** and in **FLOAT**.
  2. Attach **jacks**. Loosen **jack handle**, put **jack** on ground, and raise **jack sleeve** until fully engaging **jack retainer**. Tighten **jack handle**. Repeat for other **jack**.

Read Owner's Manual for Complete Instructions

## SAFETY PRECAUTIONS

Improper installation and operation could cause personal injury and/or equipment and property damage. Read and understand labels and the *Owner's Manual* before installing, operating, or making adjustments.

### **⚠ WARNING**

**Lower blade when vehicle is parked. Temperature changes could change hydraulic pressure, causing the blade to drop unexpectedly or damaging hydraulic components. Failure to do this can result in serious personal injury.**

### **⚠ WARNING**

**The driver shall keep bystanders clear of the blade when it is being raised, lowered, or angled. Do not stand between the vehicle and the blade or within 8 feet of a moving blade. A moving or falling blade could cause personal injury.**

### **⚠ WARNING**

**Keep hands and feet clear of the blade and A-frame when mounting or removing the snowplow. Moving or falling assemblies could cause personal injury.**

### **⚠ WARNING**

**Do not exceed GVWR or GAWR including blade and ballast. The rating label is found on driver-side vehicle door cornerpost.**

### **⚠ WARNING**

**Remove blade assembly before placing vehicle on hoist.**

### **⚠ CAUTION**

**Refer to the Kit Selection Guide/Selection List for minimum vehicle recommendations and ballast requirements.**

### **⚠ CAUTION**

**To prevent accidental movement of the blade, always turn the ON/OFF switch to OFF whenever the snowplow is not in use. The control indicator light will turn off.**

## PERSONAL SAFETY

- Remove ignition key and put the vehicle in park or in gear to prevent others from starting the vehicle during installation or service.
- Wear only snug-fitting clothing while working on your vehicle or snowplow.
- Do not wear jewelry or a necktie, and secure long hair.
- Wear safety goggles to protect your eyes from battery acid, gasoline, dirt, and dust.
- Avoid touching hot surfaces such as the engine, radiator, hoses, and exhaust pipes.
- Always have a fire extinguisher rated BC handy, for flammable liquids and electrical fires.

## HYDRAULIC SAFETY

### **⚠ WARNING**

**Hydraulic fluid under pressure can cause skin injection injury. If you are injured by hydraulic fluid, get medical attention immediately.**

- Always inspect hydraulic components and hoses before using. Replace any damaged or worn parts immediately.
- If you suspect a hose leak, DO NOT use your hand to locate it. Use a piece of cardboard or wood.

**FUSES**

The electrical and hydraulic systems contain several blade-style automotive fuses. If a problem should occur and fuse replacement is necessary, the replacement fuse must be of the same type and amperage rating as the original. Installing a fuse with a higher rating can damage the system and could start a fire. Fuse Replacement, including fuse ratings and locations, is located in the Maintenance Section of the Owner's Manual.

**FIRE AND EXPLOSION**

**⚠ WARNING**

**Gasoline is highly flammable, and gasoline vapor is explosive. Never smoke while working on a vehicle. Keep all open flames away from gasoline tanks and lines. Wipe up any spilled gasoline immediately.**

Be careful when using gasoline. Do not use gasoline to clean parts. Store only in approved containers away from sources of heat or flame.

**VENTILATION**



**⚠ WARNING**

**Vehicle exhaust contains lethal fumes. Breathing these fumes, even in low concentrations, can cause death. Never operate a vehicle in an enclosed area without venting exhaust to the outside.**

**TORQUE CHART**

**⚠ CAUTION**

**Read instructions before assembling. Fasteners should be finger tight until instructed to tighten according to the torque chart. Use standard methods and practices when attaching snowplow, including proper personal protective safety equipment.**

<b>Recommended Fastener Torque Chart (Ft.-Lb.)</b>			
Size	 SAE Grade 2	 SAE Grade 5	 SAE Grade 8
1/4-20	6	9	13
5/16-18	11	18	28
3/8-16	19	31	46
3/8-24	24	46	68
7/16-14	30	50	75
1/2-13	45	75	115
9/16-12	66	110	165
5/8-11	93	150	225
3/4-10	150	250	370
7/8-9	150	378	591
1-8	220	583	893
<b>Metric Grade 8.8 (Ft.-Lb.)</b>			
Size	Torque	Size	Torque
M 6	7	M 12	60
M 8	17	M 14	95
M 10	35	M 16	155
These torque values apply to fasteners except those noted in the instruction.			

## BLADE, PLOW GEAR, AND A-FRAME ASSEMBLY

1. Put cardboard on the floor to protect the blade's finish. Lay the blade face down on the cardboard.
2. For shipping purposes, the quadrant is attached to the A-frame. To ease assembly, remove the pivot pin from the center hole of the quadrant to separate the quadrant and A-frame.
3. Place the trip clamps around the center of the blade tube, putting one on either side of the trip stop. **Be sure to orient the trip clamps as shown in the illustration below.** Place the quadrant into the trip clamps and against the blade tube as shown. Make sure the spring anchors on the quadrant are on top.

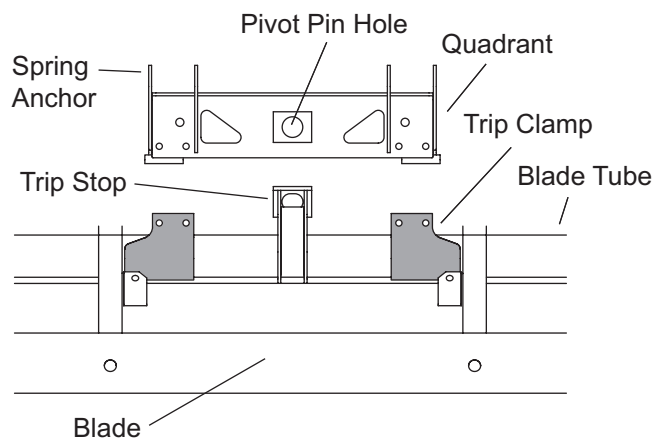

4. Slide a 3/8" flat washer onto a 3/8" x 1" cap screw, and insert the cap screw through the trip clamp and quadrant. Attach a 3/8" flat washer and a 3/8" locknut to the cap screw, then hand tighten. Attach all eight cap screws. Once all of the cap screws are on, fully tighten them.

**Check that clamps rotate freely up and down. If clamps do not rotate freely, loosen fasteners an equal number of turns until free rotation is obtained.**

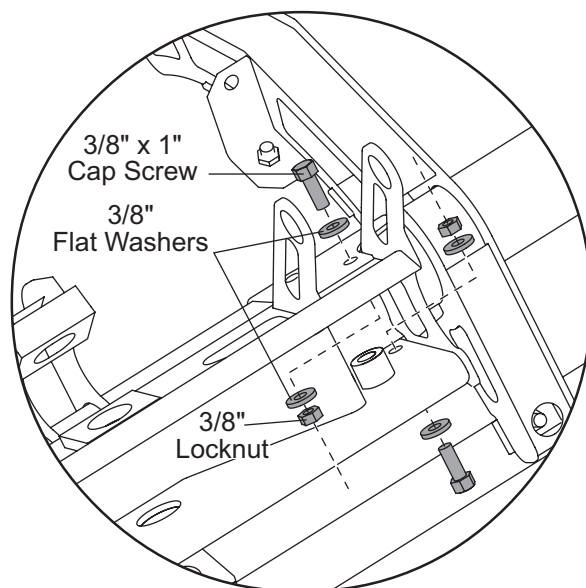

5. Place the nose of the A-frame into the quadrant, and align the pivot holes. Inserting the tapered end first, slide the pivot tube down through quadrant and the nose of A-frame.

6. Add a trip bumper to each end of the pivot tube as shown below. The round boss on the bumper will fit into the pivot tube, and the long bumper leg will butt up against the upward bend of the quadrant. Place a 5/16" flat washer on a 5/16" x 5" cap screw, and slide the cap screw through bumpers. Attach a 5/16" flat washer and a 5/16" locknut to the cap screw, and tighten until the rubber on the bumpers begins to dimple.

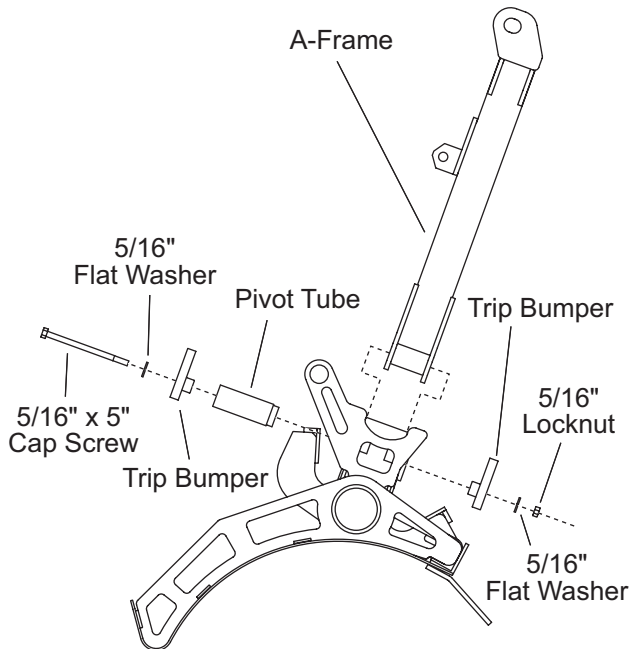

7. Place the blade in the upright position so that the A-frame is sitting on the floor. Place the plow gear into position straddled over the A-frame. Align the lower holes in the plow gear with the holes in the A-frame pushers. Attach the A-frame to the plow gear with two 3/4" pins and two 5/32" cotter pins.

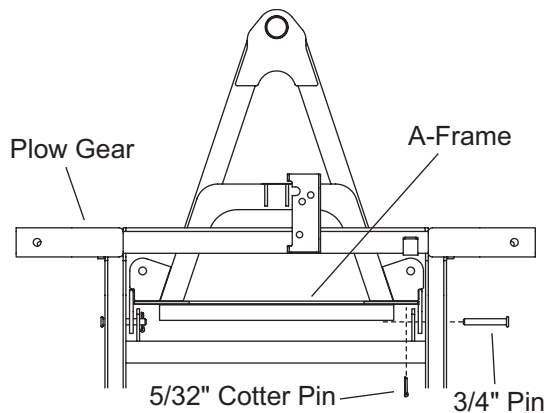

8. Assemble the jacks. Place the jack through the jack sleeve, and tighten the threaded jack handle. Add a square vinyl cap to the top of each jack leg.

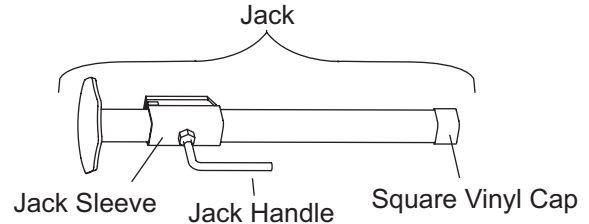

9. Attach the jacks to the plow gear. Position the jack sleeves so the jacks will keep the plow gear upright and the A-frame parallel to the ground while the remaining components are attached.

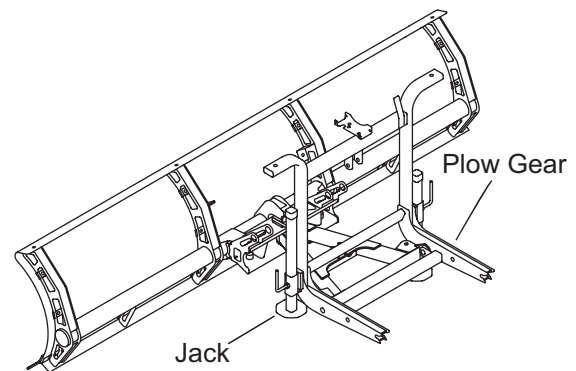

10. Remove end moldboard fasteners (a T45 TORX® driver is needed) and discard. Install a blade guide on each end of the blade as shown. Ream holes if necessary.

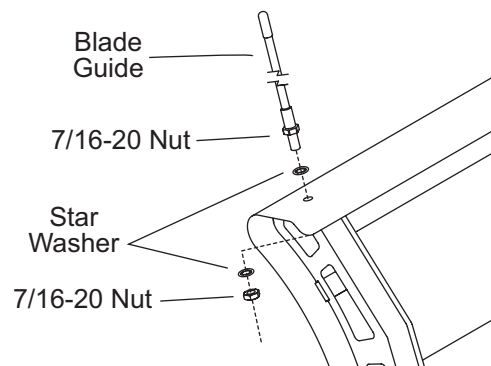

## RECEIVER ASSEMBLY INSTALLATION

1. Line up a spring with the connecting pin holes.
2. Slide a connecting pin through the holes and spring.
3. Put a cotter pin through the connecting pin on the far side of the spring. Be sure to fully bend both legs of the cotter pin.
4. Slide the receivers onto the truck mount (should already be installed on the vehicle) with the connecting pins toward the outside.
5. Slide a pin into both holes on each receiver and secure each pin with a 1/8" hair pin.

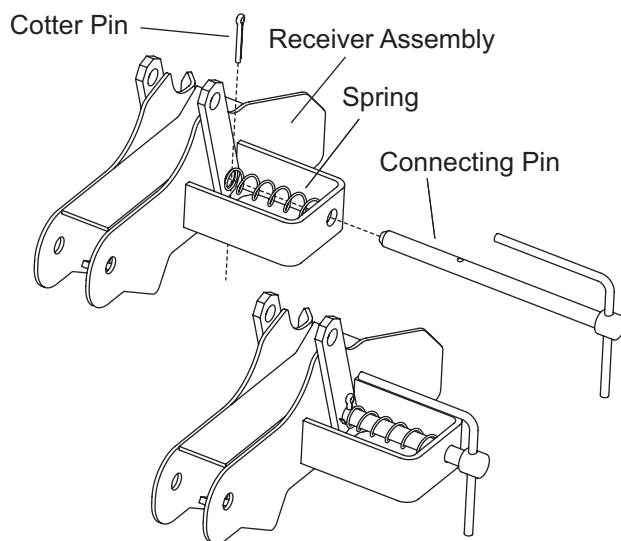

## HYDRAULIC UNIT INSTALLATION

### Preparing Rams for Installation

1. Remove the plug from the port of one of the angle rams.
2. Select a 90° elbow, and turn the jam nut as far back as possible.

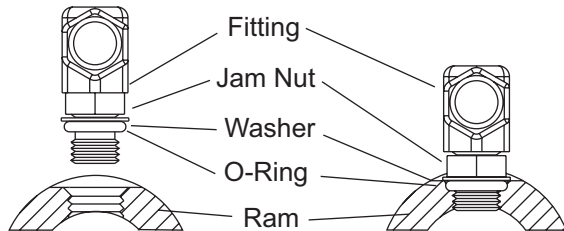

3. Lubricate the O-ring with clean hydraulic fluid.
4. Screw the fitting into the angle ram port by hand as far as it will go. (The washer should be in contact with both the port face and the shoulder of the jam nut.)
5. Unscrew the fitting to its proper position (no more than one full turn).
6. Use one wrench to hold the fitting body in position, and tighten the jam nut with another wrench until the washer again contacts port face. **Tighten 1/8 to 1/4 turn to lock the fitting in place.**
7. Repeat steps 1–6 for the port on the other angle ram and for both ports on the lift ram. Orient the fittings as shown below.

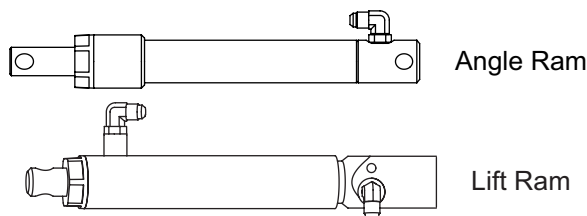

### ⚠ CAUTION

Overtightening the swivel nut will damage the hydraulic hose.

8. Attach 36" HP hoses to the angle rams. Attach the 8" HP hose to the square end of the lift ram, and attach the 22" HP hose to the other end of the lift ram. Hand tighten the hoses, then use one wrench to hold the hose in position and another wrench to tighten flare nut 1/8 to 1/4 turn beyond hand tight.

### Attaching Lift and Angle Rams

1. Rotate the plow gear forward until the cross member contacts the A-frame.

**NOTE: Keep the lift ram collapsed as much as possible until after you attach and tighten all of the hoses and fill the hydraulic system with fluid.**

2. Attach the square end of the lift ram to the plow gear with a 1/2" x 3" cap screw and a 1/2" locknut. Attach the other end of the lift ram to the A-frame with a 1/2" x 2-1/2" cap screw and a 1/2" locknut. Do not fully tighten the locknuts that secure the ram; only two or three threads should be showing past the locknut.

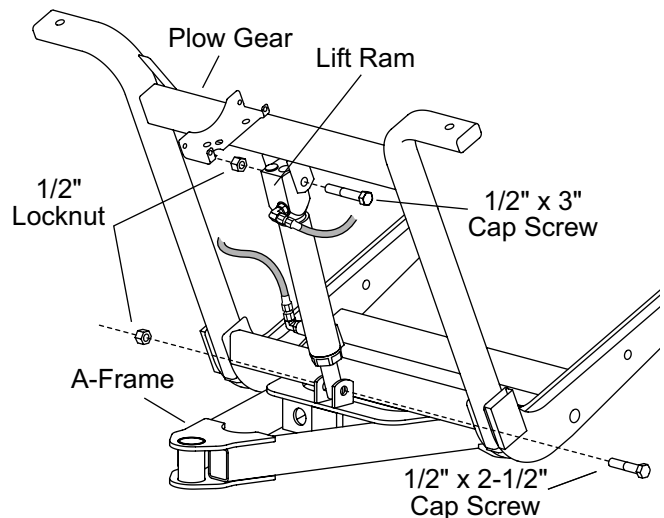

3. With the fittings facing the A-frame, attach each angle ram to the quadrant with a 1/2" x 4" cap screw and 1/2" locknut. Use 1/2" x 3" cap screws and 1/2" locknuts to attach the angle rams to the A-frame. Do not fully tighten the locknuts that secure the rams; only two or three threads should be showing past the locknut.

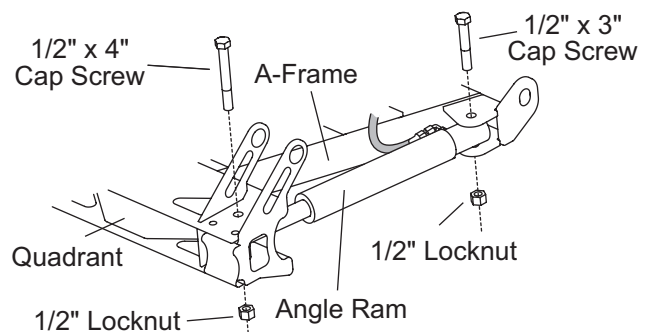



## Mounting Hydraulic Unit

1. Attach the hydraulic unit to the plow gear using two 1/4" x 2-3/4" cap screws and two 1/4" locknuts.

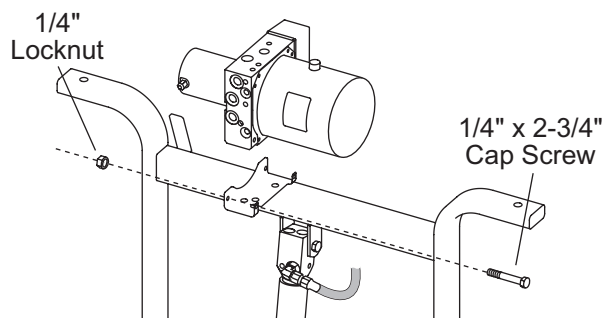

2. Remove the plugs from the angle ports, lift port, and reservoir. Screw 90° elbows into the angle and lift ports. Screw a straight fitting into the bottom of the reservoir. Screw the filler breather plug into the top of the reservoir.

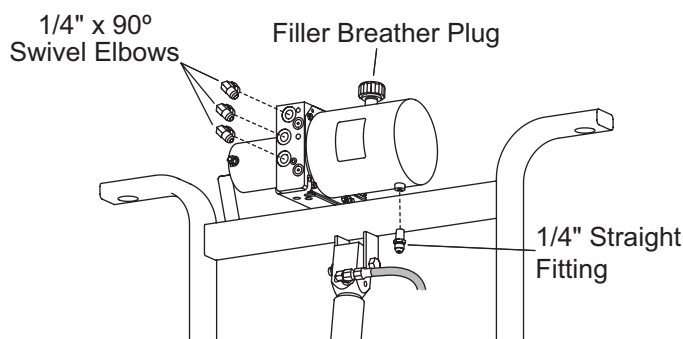

3. Looking at the front of the vehicle, orient the swivel elbows in the angle and lift ram ports as shown, then tighten these elbows and the straight fitting using the procedure on the previous page.

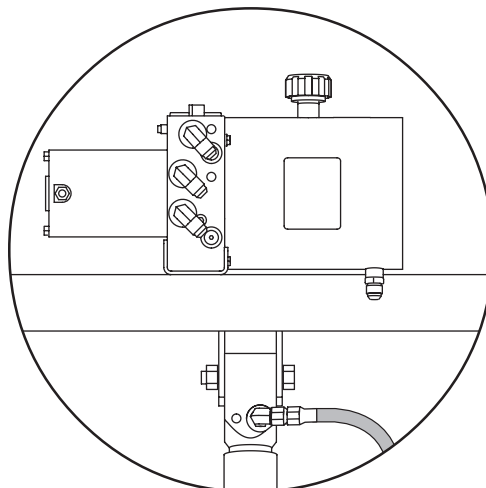

4. Route hydraulic hoses as shown. Take care to align the hoses so there are no twists or sharp bends and so they will not be pinched or pulled by moving parts.

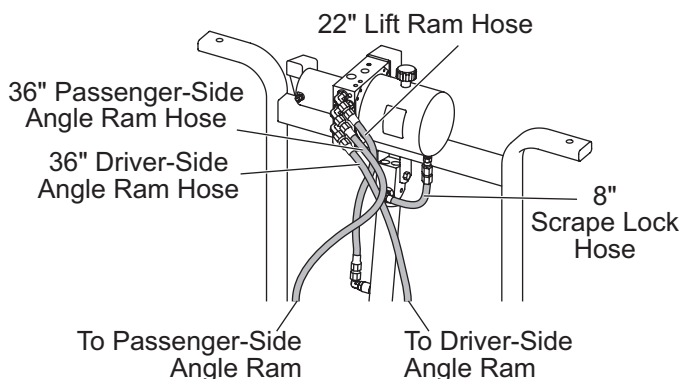

5. Tighten hoses using the procedure on the previous page.

## TRIP SPRING INSTALLATION

**NOTE: The angle rams and angle ram fasteners must be attached and tightened (two or three threads should be showing past the locknut) before beginning this section.**

1. Install a 5/32" cotter pin into a spring pivot, then insert the pivot into one of the spring anchors on the quadrant. Place a spring in position between the spring anchors, and push the spring pivot into the spring. Line the spacer up with the hole in the spring, then push the spring pivot through the spacer and the other spring anchor. Although the spacer can go on either the driver or passenger side of the blade, the spacer should be placed toward the inside of the quadrant with the spring on the outside. Repeat on the other side, but use two springs instead of a spring and spacer. Finally, install a 5/32" cotter pin through the remaining holes of each spring pivot.

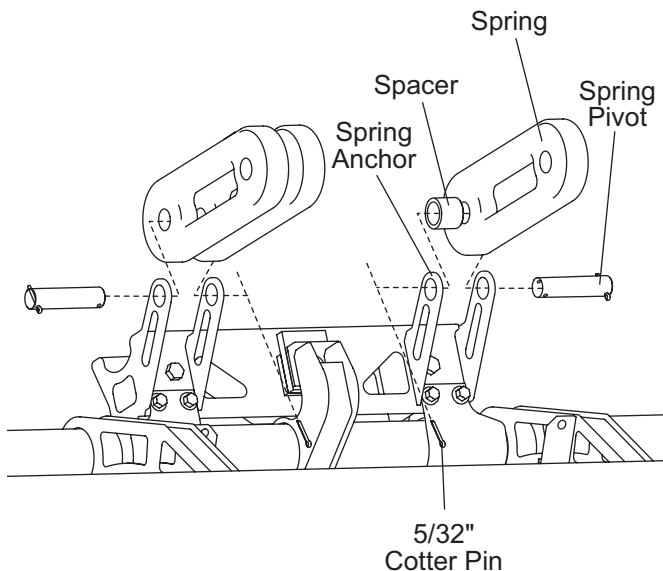

2. Place the spring bar through all three springs. Position the bar so that its holes line up with the holes in the blade tabs. Insert 3/8" x 3-1/2" cap screws through the tabs and the spring bar. Place a 3/8" washer and 3/8" nut onto each cap screw. On one side, tighten the nut halfway up the cap screw. On the other side, tighten the nut fully. Now, fully tighten the first nut as well. Place a second 3/8" nut onto each cap screw. Fully tighten these nuts against first set. The spring bar should now be up against the blade tabs.

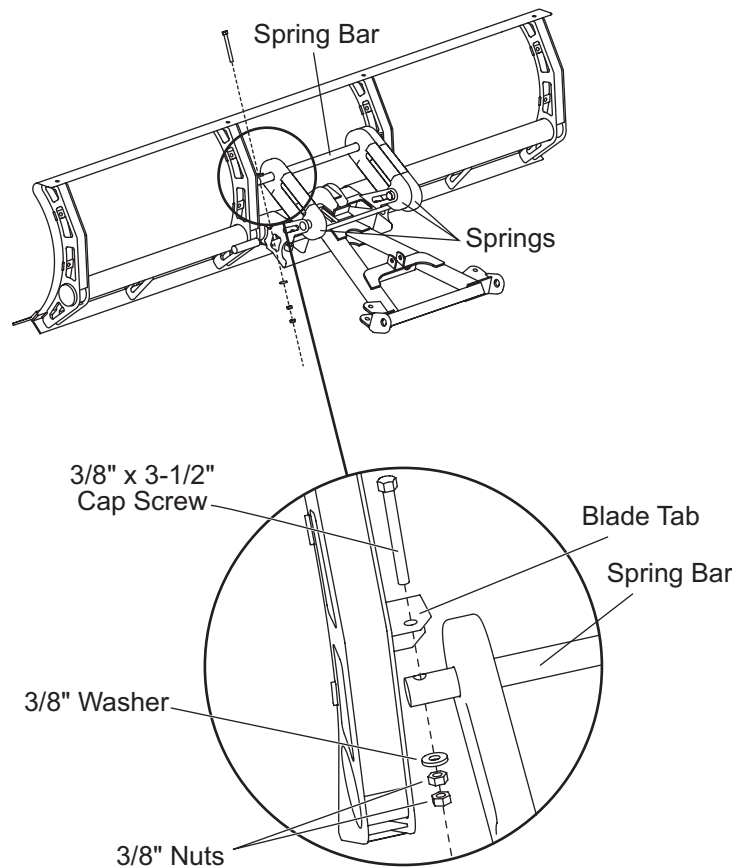

## HEADLAMP INSTALLATION

### **⚠ WARNING**

**Your snowplow must be equipped with headlamps and directional lights.**

- Slide a headlamp swivel onto the screw on the underside of the driver-side headlamp assembly. The park/turn lamp should be to the outside of the plow gear.
- Locate a 1/2" flat washer from the plow gear kit. Slide the washer into the end of the plow gear tube on the driver side. Fit the screw from the headlamp through the hole in the top of the plow gear and through the flat washer. Secure with a lock washer and nut from the headlamp kit.
- Repeat steps 1 and 2 on the passenger side.
- Route the black/orange ground wire from the snowplow lighting harness to the NEGATIVE (-) motor terminal.
- Read, follow, and remove the headlamp label if one is present.

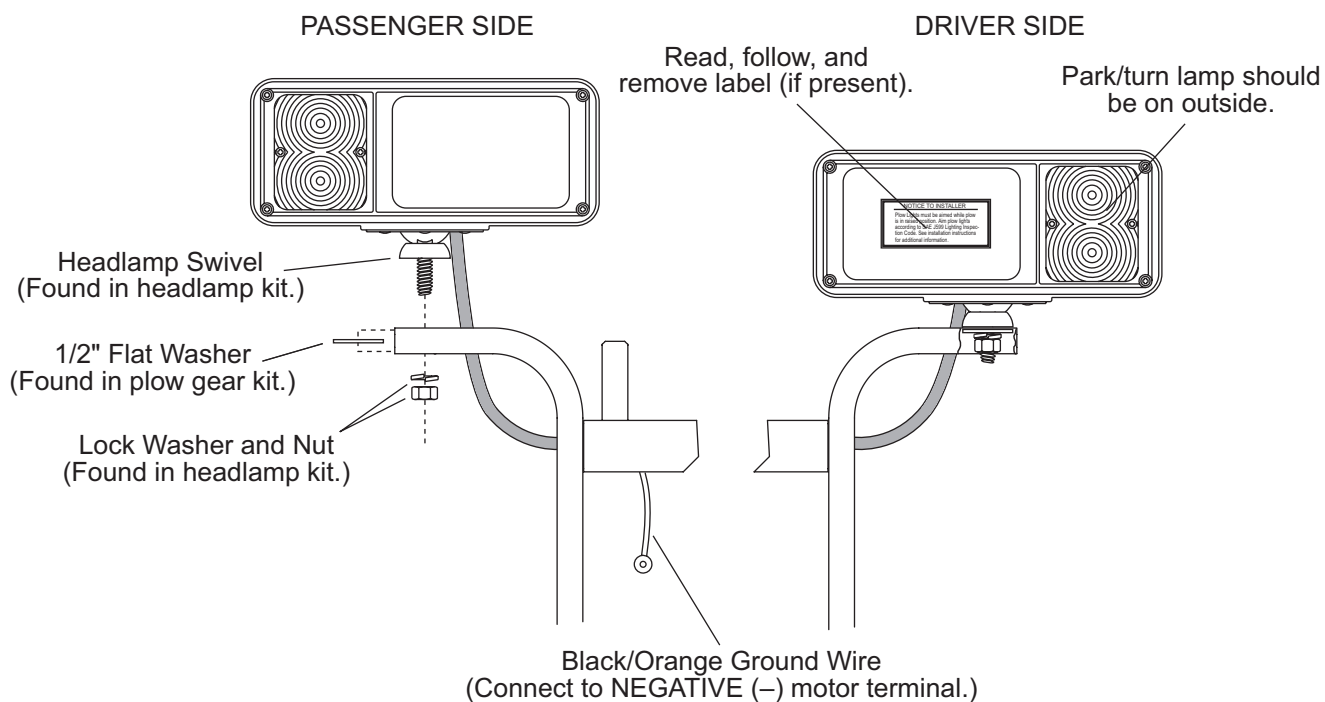

## SNOWPLOW CONTROL HARNESS AND CABLE INSTALLATION

**NOTE: Use dielectric grease to prevent corrosion on all electrical connections. Fill receptacles and lightly coat ring terminals and blades before assembly.**

1. Remove the valve cover, and connect the snowplow control harness to the valve coil terminals according to the instructions inside the valve cover.

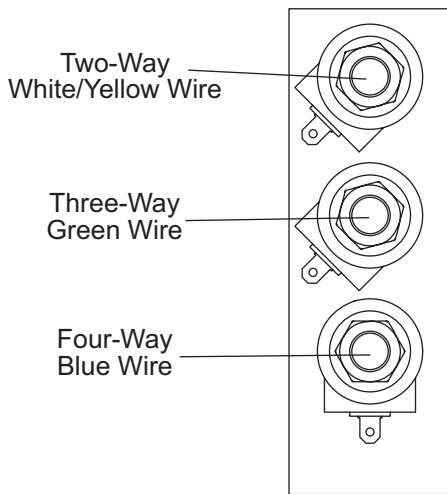

Black/Orange Wire to Each Coil

**NOTE: The strain relief must be inside the cover to prevent unnecessary strain on the valve coil terminals.**

2. Apply anti-seize lubricant to the fasteners, and reinstall the valve cover.

3. Connect the black wire from the snowplow battery cable and the two black/orange wires (from the control harness and the snowplow lighting harness) to the NEGATIVE (-) motor terminal (see label on motor). Connect the black wire with the red stripe to the POSITIVE (+) motor terminal.

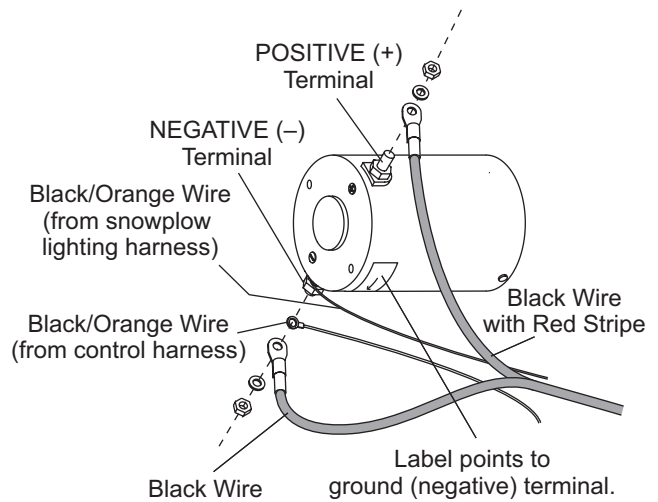

4. Cable tie the harnesses and battery cable to the plow gear as shown below.
5. Install the cable boot. Plug the battery cable into the cable boot for storage.

**NOTE: Snowplow lighting and control harnesses plug into one another for storage.**

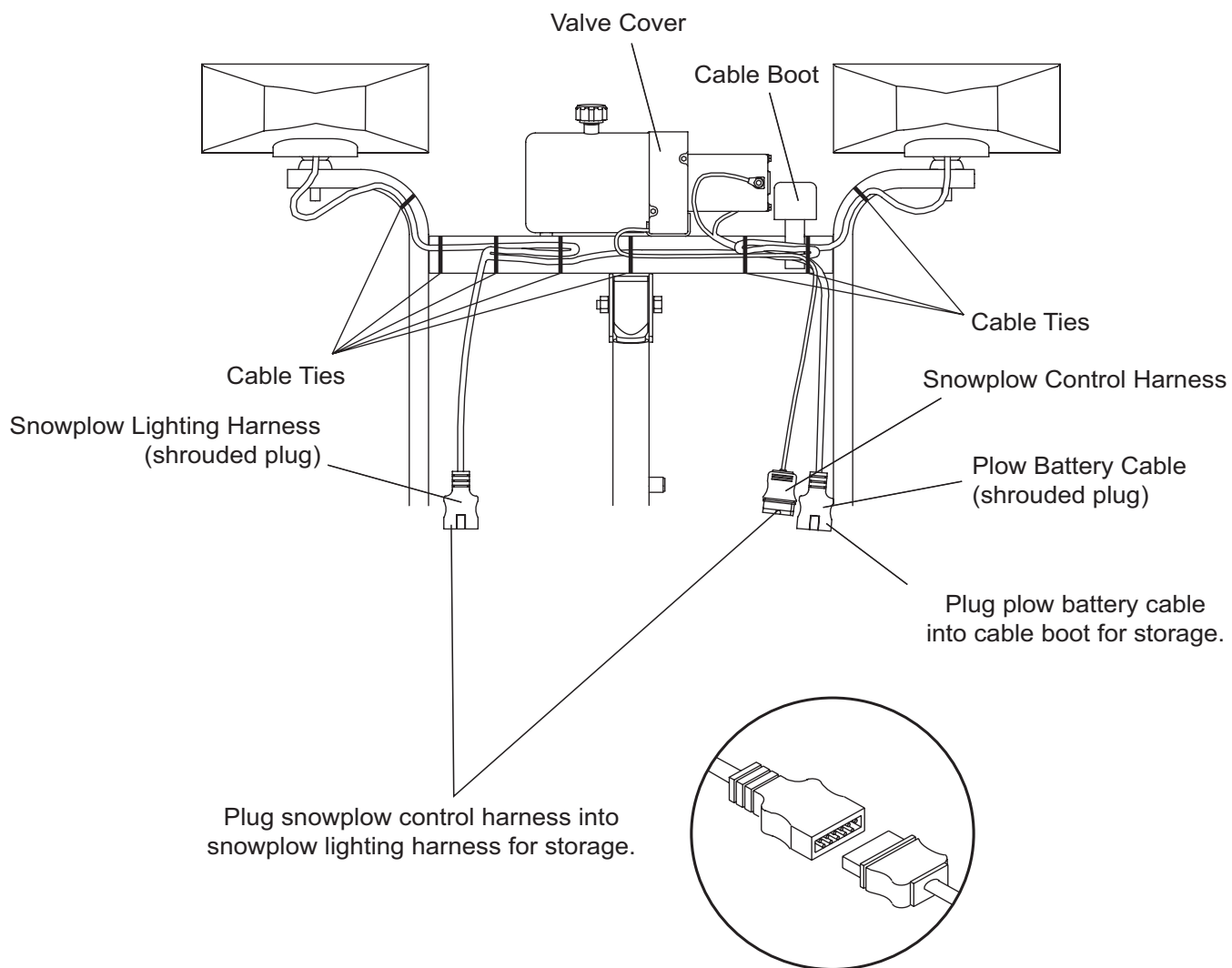

## FILLING HYDRAULIC SYSTEM

### **⚠ CAUTION**

**Do not mix different types of hydraulic fluid. Some fluids are not compatible and may cause performance problems and product damage.**

These steps are only intended for the initial filling of the hydraulic system. For subsequent hydraulic system filling procedures and maintenance, see Owner's Manual.

1. Completely assemble the blade, plow gear, hydraulic system, and headlamps. Make sure the jacks are supporting the plow gear and the plow gear is rotated forward so that the cross member is in contact with the A-frame.
3. Remove the filler breather plug. Using new high performance hydraulic fluid (available from your sales outlet), fill the hydraulic reservoir until the dipstick on the filler breather plug reads full. Reinstall the filler breather plug.

#### System Capacity:

Unit reservoir – 1-3/4 quarts

System total – 2-1/8 quarts

4. Rotate the plow gear back until the attachment arms are parallel to the ground. Rotating the plow gear beyond this point will make attaching the snowplow to the vehicle difficult.

5. Complete the electrical installation in the vehicle, and install the control. Attach the snowplow to the vehicle, and plug in the electrical connectors.

### **⚠ WARNING**

**Keep 8' clear of the blade drop zone when it is being raised, lowered or angled. Do not stand between the vehicle and blade or directly in front of blade. If the blade hits you or drops on you, you could be seriously injured.**

6. Angle the blade left and right several times to purge the air from the angle rams. Having the ported ends of the angle rams at a higher level than the rod ends will speed up the purging process.
7. Raise and lower the blade several times to purge the air from the lift ram.
8. Lower the blade to the ground. Refill the hydraulic reservoir so the fluid level is between the marks on the dipstick when the filler breather plug is fully installed. Do not overfill. Reinstall the filler breather plug.

## SCRAPE LOCK PRESSURE ADJUSTMENT

Although the scrape lock system comes preset from the factory, it may be adjusted if needed. The relief valve stem in the top of the lift ram adjusts this setting.

### ⚠ WARNING

**Lower blade when vehicle is parked. Keep 8' clear of blade drop zone. Temperature changes could change hydraulic pressure, causing the blade to drop unexpectedly or damaging hydraulic components. Failure to do this can result in serious personal injury.**

### ⚠ CAUTION

**To prevent accidental movement of the blade, always turn the ON/OFF switch to OFF whenever the snowplow is not in use. The control indicator light will turn off.**

1. Attach the plow to the vehicle.
2. Raise and lower the blade several times to purge air from the lift ram.

**NOTE: If blade will not raise or raises too slowly, the setting is too high. Decrease the setting until blade will raise easily. Likewise, if backdrag performance has decreased, the setting is too low. Increase the setting until optimal backdrag performance is reached.**

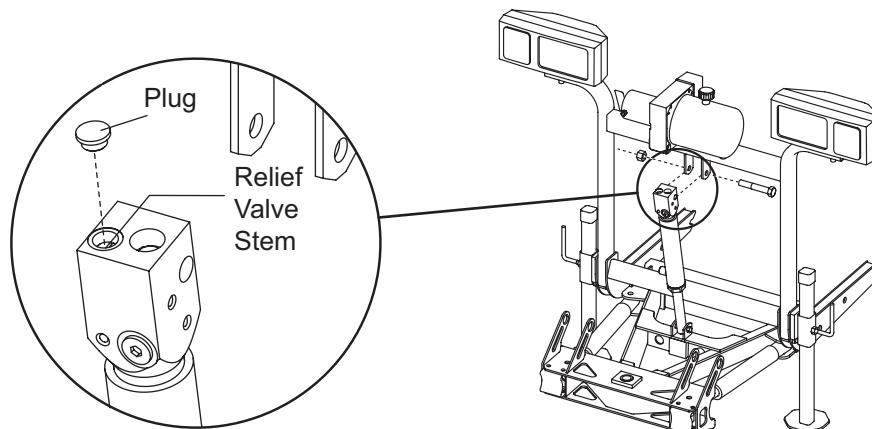

### ⚠ WARNING

**Hydraulic fluid under pressure can cause skin injection injury. If you are injured by hydraulic fluid, get medical attention immediately.**

3. The recommended pressure setting is 1000–1200 psi. To check the pressure setting, install a T-fitting with a pressure gauge in the rod-end hydraulic line, and observe the pressure reading as the blade is raised. If a pressure gauge is not available, increase the scrape lock setting as high as possible without severely limiting the blade raise speed.
4. To gain access to the relief valve stem, remove the 1/2" x 3" cap screw that attaches the lift ram to the top of the plow gear, and remove the plug covering the slotted head of the relief valve stem.
5. Adjust the scrape lock pressure setting by using a slotted-head screwdriver. Turn the relief valve stem IN (clockwise) to increase the scrape lock pressure; turn the relief valve stem OUT (counterclockwise) to decrease it.

**NOTE: Adjustments should be made in 1/8-turn increments.**

6. Reattach the lift ram to the plow gear after adjustment.
7. Remove the 1/2" x 3" cap screw that attaches the lift ram to the top of the plow gear, reinstall the plug over the relief valve stem, and reattach the lift ram.

## VEHICLE LIGHTING CHECK

1. Check the operation of vehicle and plow lights with plow mounted to vehicle and all harnesses connected.

### Turn signals and parking lamps

Parking lamps ON:

- Both vehicle and plow parking lamps should be on at the same time.

Driver-side turn signal ON:

- Both vehicle and plow driver-side turn signal lamps should flash at the same time.

Passenger-side turn signal ON:

- Both vehicle and plow passenger-side turn signal lamps should flash at the same time.

### Headlamps

Move vehicle headlamp switch to the ON position. Connecting and disconnecting the headlamp harness plug from the vehicle harness connector should switch between vehicle and plow headlamps as follows:

Headlamp harness plug DISCONNECTED:

- Vehicle headlamps should be on.
- Plow headlamps should be off.

Headlamp harness plug CONNECTED:

- Plow headlamps should be on.
- Vehicle headlamps should be off.

Dimmer switch should dim whichever headlamps are operating. The high beam indicator on the dash should light when either set of headlamps is on high beam.

### Daytime Running Lamps (DRLs)

With headlamp switch off, activate the DRLs.

Headlamp harness plug DISCONNECTED:

- Vehicle DRLs should be on.
- Plow headlamps should be off.

Headlamp harness plug CONNECTED AND vehicle uses the headlamp bulbs for DRLs:

- Plow headlamps should be on in DRL mode (with reduced intensity compared to high or low beam).
- Vehicle DRLs should be OFF.

Headlamp harness plug CONNECTED AND vehicle uses lamps **other than** the headlamp bulbs for DRLs:

- Plow headlamps should be on in DRL mode (with reduced intensity compared to high or low beam).
- Vehicle DRLs should be on.
- Vehicle headlamps should be off.

### Joystick Control or Hand-Held Control

The control indicator light should light whenever the control ON/OFF switch and the ignition (key) switches are both in the ON position. The plow plugs do not need to be connected to the vehicle harness connectors.

2. Connect all plow and vehicle harnesses. Raise the plow and aim plow headlamps according to the Snowplow Headlamp Beam Aiming instructions included with the headlamps and any state or local regulations.
3. Check aim of vehicle headlamps with plow removed.
4. When the plow is removed from the vehicle, install the plug cover on the vehicle battery cable connector and insert the plow battery cable connector into the cable boot on the plow. On both the vehicle and plow, the lighting harness and control harness connectors plug into one another for storage.

## OWNER'S MANUAL PACKET

If the completed plow will be delivered immediately, the Owner's Manual should be reviewed with and given to the purchaser.

If the plow is completed prior to delivery to the purchaser, attach the Owner's Manual Packet to the electrical cable of the cab control for safekeeping.

The company reserves the right under its product improvement policy to change construction or design details and furnish equipment when so altered without reference to illustrations or specifications used. This equipment manufacturer or the vehicle manufacturer may require or recommend optional equipment for snow removal. Do not exceed vehicle ratings with a snowplow. The company offers a limited warranty for all snowplows. See separately printed page for this important information.