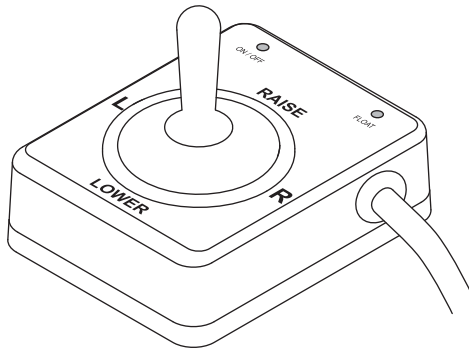

INSTALLATION INSTRUCTIONSMarch 15, 2008
Lit. No. 49483, Rev. 00**⚠ CAUTION**

Read this document before installing the Joystick Controls.

⚠ CAUTION

Use standard methods and practices when attaching snowplow and installing accessories including proper personal protective safety equipment.

⚠ CAUTION

See your BLIZZARD® outlet for specific application recommendations before installation. The Selection List has specific vehicle and snowplow requirements.

FUSES

The BLIZZARD electrical and hydraulic systems contain several automotive blade-style fuses. If a problem should occur and fuse replacement is necessary, the replacement fuse should be of the same type and amperage rating as the original. Installing a fuse with the higher rating could damage the system.

NOTE: The controls (4-pin square connector) do not contain on-board fuses. Consult your snowplow Owner's Manual for fuse replacement. Fuses are located both underhood and on the hydraulic unit.

NOTE: Circuit board may be damaged by static electricity. Always touch ground before handling PC board.

CONTROL PLACEMENT**⚠ CAUTION**

Do not alter, modify or install additional components in shaded areas of the illustration below. Failure to comply may interfere with air bag deployment or cause injury to operator in an accident.

When choosing a location for your control, it should be mounted in easy reach of the vehicle operator and not restricting access to vehicle controls or vehicle instrumentation. Do not mount the control in areas prohibited by the vehicle manufacturer for crash worthiness. See the vehicle's body builder's book, owner's manual, or service manual for details. The shaded areas in the illustration below show the most commonly restricted areas.

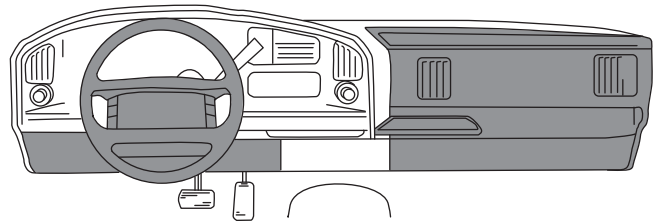

INSTALLING DASH BRACKET

⚠ CAUTION

Before drilling holes, check to be sure that no vehicle wiring or other components could be damaged.

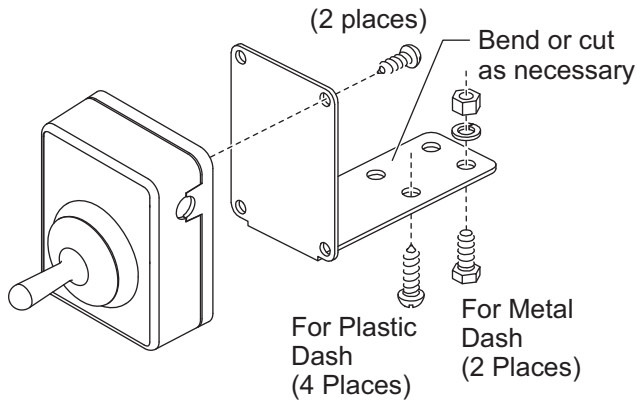

Metal Dash Only:

1. Using two of the four clearance holes on narrow end of the bracket as guides, drill two 9/32" holes in dash.
2. Attach control to control bracket with two #8 x 5/8" self-tapping screws, or with the PRO-GRIP Mount Kit (PN 49305K) as instructed.
3. Attach bracket to dash with two 1/4" x 3/4" cap screws, 1/4" lock washers and 1/4" nuts.

Plastic Dash Only:

1. Using the four clearance holes on the narrow end of the bracket as guides, drill four 9/64" tap holes in dash.
2. Attach bracket to dash with four #12 x 3/4" self-tapping screws.

PRO-GRIP MOUNT KIT

The PRO-GRIP Mount Kit will secure your BLIZZARD® joystick control to interior vehicle cab surfaces. Possible mounting areas may include front or side of dash, center console, etc. Location will depend on operator preference and mounting clearance with other vehicle controls. Once the control is properly mounted, it can be easily removed and stored.

Installation should be done at temperatures above 60°F (15.6°C).

1. Select the area of the cab where control will be mounted.
2. Clean installation area and surface of control with isopropyl alcohol or mineral spirits. Allow surface to dry for 15 minutes.
3. Determine length of dual locking strip required. **Do not obstruct the ON/OFF switch.**

For flat surfaces: Use full length locking strips mounted along the length of the control. Strips may be placed on the back of the side of the control.

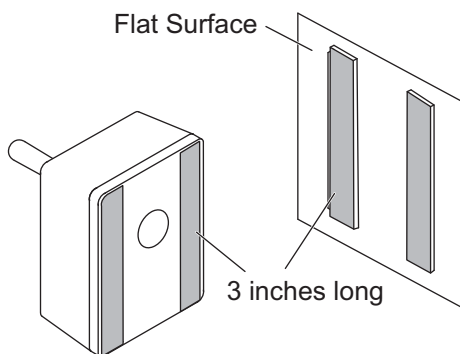

For curved surfaces: Cut the locking strips to 2 inches. These strips must be placed parallel to the curved surface.

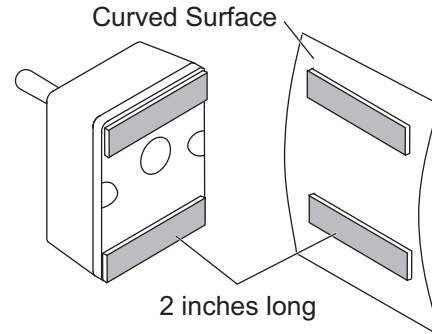

4. Once the selected surfaces are prepared, remove the adhesive back protection strip and press the locking strips into place. Apply pressure across entire surface to work out any trapped air bubbles.
5. Allow the locking strip adhesive to set for 24 hours before mounting the control to the cab surface.

The control can be easily removed by applying a sideways lifting motion to the control. Do not apply excessive force. If the control does not release, gently pry up in the opening under the control with a screwdriver or other flat object.

The PRO-GRIP locking strips can be removed from control and mounting location if no longer needed. Adhesive residue can be cleaned up with mineral spirits.

Copyright © 2008 Douglas Dynamics, L.L.C. All rights reserved. This material may not be reproduced or copied, in whole or in part, in any printed, mechanical, electronic, film or other distribution and storage media, without the written consent of Blizzard. Authorization to photocopy items for internal or personal use by the Blizzard outlets or snowplow owner is granted.

Blizzard reserves the right under its product improvement policy to change construction or design details and furnish equipment when so altered without reference to illustrations or specifications used. Blizzard or the vehicle manufacturer may require or recommend optional equipment for snow removal. Do not exceed vehicle ratings with a snowplow. Blizzard offers a limited warranty for all snowplows and accessories. See separately printed page for this important information. The following are registered (®) or unregistered (™) trademarks of Douglas Dynamics, L.L.C.: BLIZZARD®.

Printed in U.S.A.
