

6211

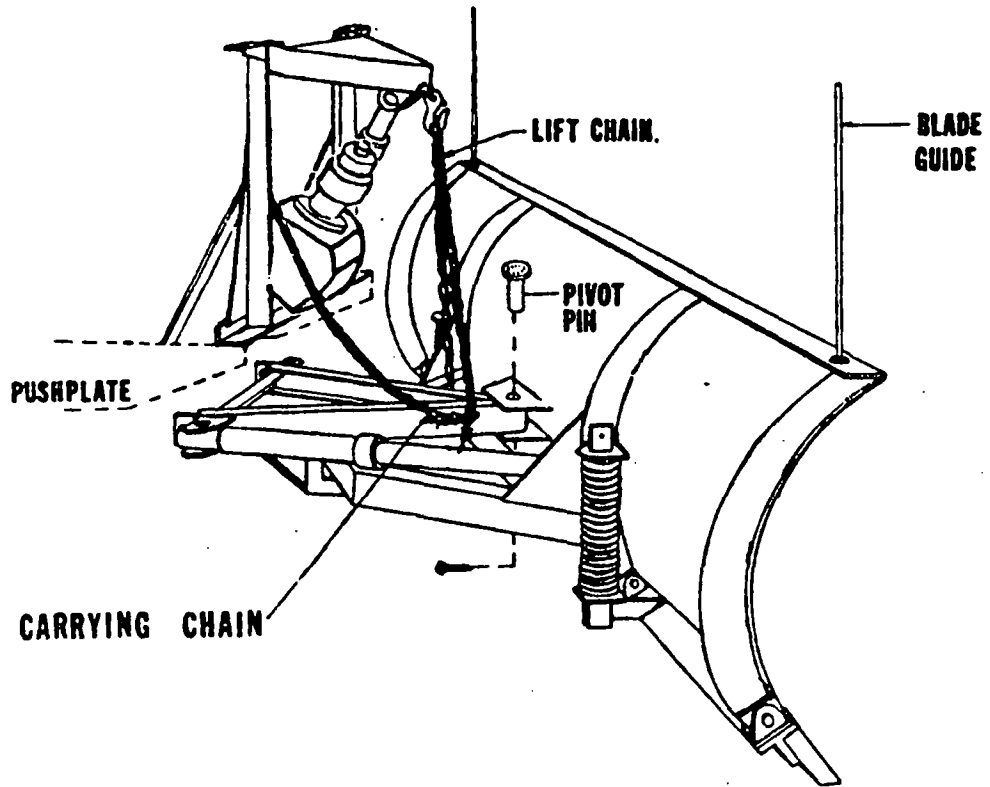

**TYPICAL DASH MOUNT**

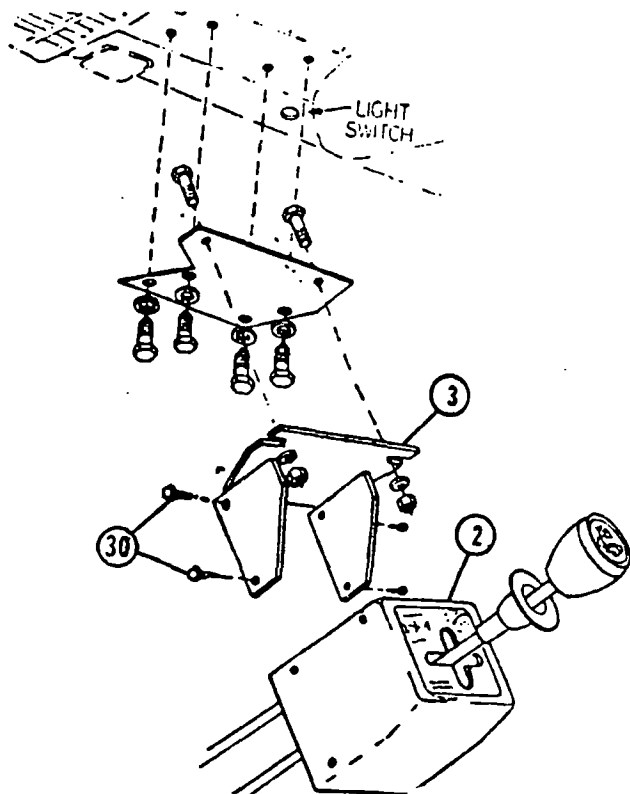

**LIFT VALVE & GENERAL**

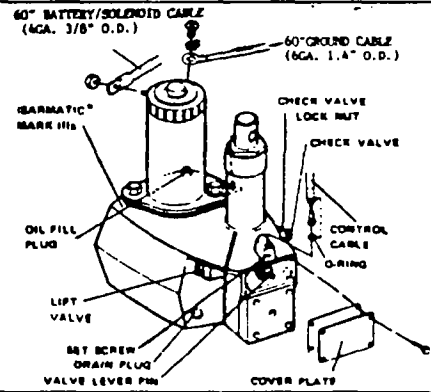

**ANGLE VALVE**

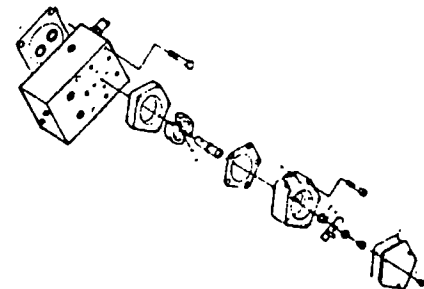

## PARTS LIST

A6125

REF#	QTY	PART#	DESCRIPTION
1	1	A5796	FISHER ELEC PAK 6" 2500 PSI
2	1	A5929	SINGLE LEVER CONTROL W/CABLES
2A	1	5931	CABLE W/CLIP & O-RING (90")
2B	1	5930	CABLE W/CLIP & O-RING (ADJ 90")
3	1	5847	SLC ADAPTOR BRACKET
4	2	A318	10" ANGLE CYLINDER ASSEMBLY
5	2	6814	CLEVIS PIN
6	4	6816	ANCHOR PIN
7	6	90601	1/4 X 1-1/2 COTTER PIN
8	1	376	32" H.P. HOSE, 1/4 P TO 1/4 P
9	1	3074	22" H.P. HOSE, 1/4 P TO 1/4 P
10	2	A1587	DISCONNECT ASSEMBLY
11	2	1588	DUST PLUG
12	2	5804	1/4" HEX NIPPLE
13	1	765	1/4" BRASS BAR STREET ELL
14	2	2780	1/4" BRASS BAR STREET ELL (FORGED)
15	1	5129	FUSE HOLDER
16	2	2540	#16 EYE TERMINAL
17	1	4302	3M 560 INLINE CONNECTOR
18	1	4303	FEMALE CONNECTOR
19	1	5048	MALE CONNECTOR
20	1	5794	SOLENOID
21	1	5797	60" CABLE (RED)
22	1	5798	60" GROUND CABLE (BLACK)
23	1	5799	22" CABLE (RED)
24	1		SAFETY DECAL
25	4	3042	GROMMET
26	1	5802	HOSE GROMMET
27	4	3666	TIE WRAPS
28	2	5801	CABLE CLAMP
29	2	5803	#10 X 1" SELF TAPPING SCREWS
30	4	5800	#8 X 5/8" SELF TAPPING SCREWS
31	2	90016	1/4 X 3/4 (NC) CAPSCREW *
32	2	90311	1/4 FLATWASHER *
33	2	90350	1/4 (NC) LOCKNUT *
34	1	90692	5/16 EX TOOTH LOCKWASHER *
35	1	90691	5/16-18 X 1/2 CAPSCREW
36			
37	1	5703	#16 WIRE, 8' LONG
38	1	5793	#16 BARREL CONNECTOR

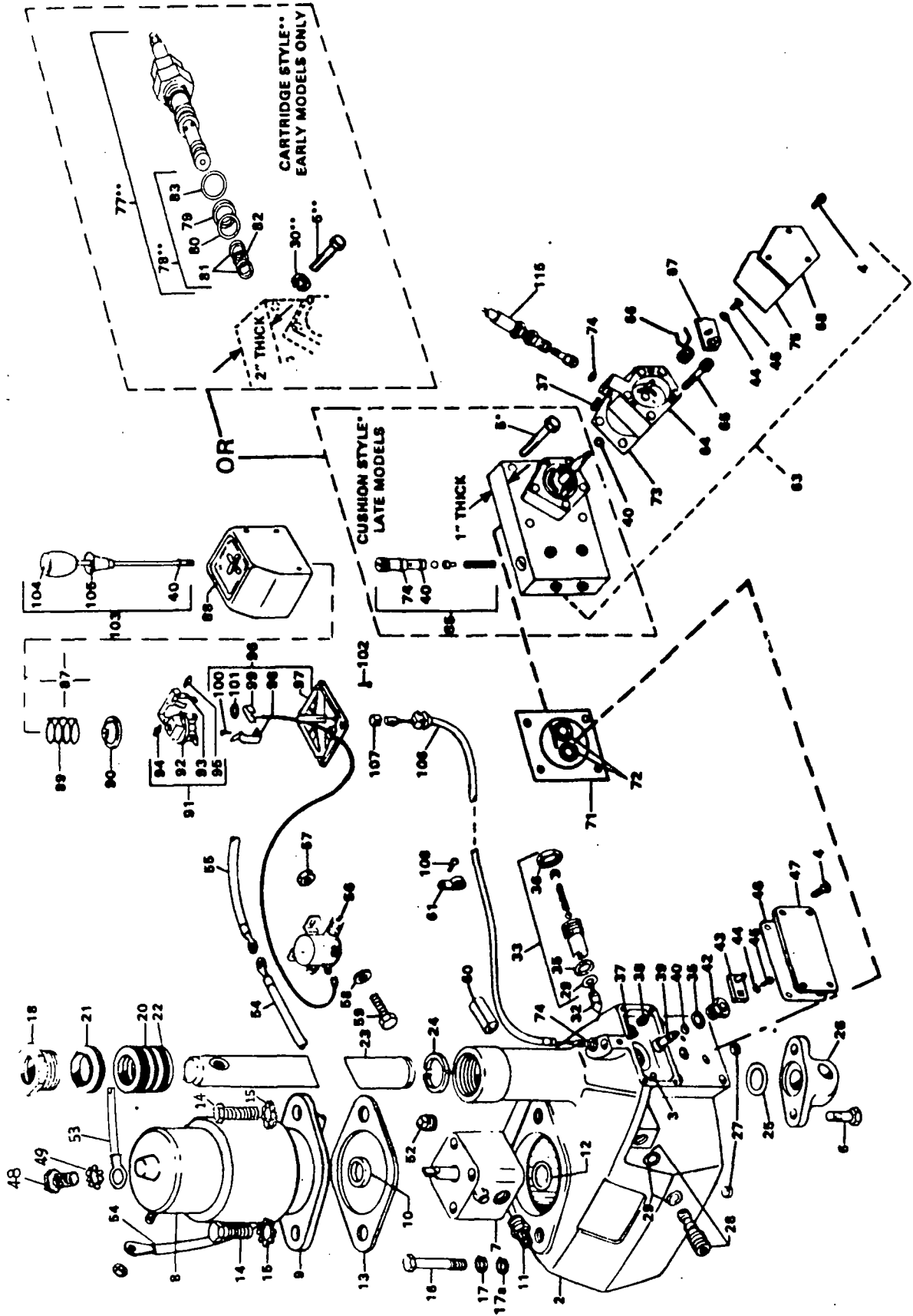

# SERVICE PARTS LIST

Item	Part No.	Qty.	Description	Item	Part No.	Qty.	Description
* Notes parts for Crossover Relief with 1" thick block and Cushion Valves (Late Models)							
**Notes parts for Crossover Relief with 2" thick block and Cartridge Valve (Early Models)							
1	A5796	1	Fisher Electric/Hydraulic Pak 6" (2500 PSI) (Not Shown)	57	80350	2	Locknut — 1/4"-20
	A5808	1	Fisher Electric/Hydraulic Pak 10" (4000 PSI) (Not Shown)	58	90311	2	Flat Washer — 1/4" Standard
	6972	1	Fisher Commercial EHP 6" (2500 PSI) (Not Shown)	59	90018	2	Capscrew — 1/4"-20 x 3/4"
Item 1 consists of the Out-Front PAK only, and does not include the Single Lever Control, cables, hoses or cylinders Available with Cushion Style Crossover Reliefs only.				60	5802	2	Hose Grommet
2		1	Main Housing (8")	61	5801	2	Cable Clamp
		1	Main Housing (10")	63	A5838-25	1	Angling Valve Assembly — 6" (2500 PSI)*
		1	Main Housing (8" Commercial)		A5838-40	1	Angling Valve Assembly — 10" (4000 PSI)*
		1	Expansion Plug — 1/4"	37	8062	1	Half Dog Point Set Screw — #10-24 x 3/8"
3		1	Expansion Plug — 1/4"	64	6579	1	Cable & Linkage Enclosure
4	6063	4	Hex Head Tapping Screw — #10-24 x 5/8"	65		8	Socket Head Capscrew — 1/4"-20 x 1-1/2"
5	90035	4	Capscrew — 1/4"-20 x 2-3/4" — Grade 5**	66	6576	1	Torsion Spring
		4	Capscrew Thread Forming — 1/4"-20 x 1-3/4**	67		1	Valve Lever
		2	Capscrew Thread Forming — 5/16"-18 x 1-1/4"	44		1	Lock Washer #6 — External
6		2	Capscrew Thread Forming — 5/16"-18 x 1-1/4"	45		1	Pan Head Machine Screw — #6-32 x 1/4"
7	A5818	1	Hydraulic Pump Assembly (MTE) (1450-1800 PSI)	68	6573	1	Enclosure Cover
	7049	1	Hydraulic Pump Assembly (MTE) Die Cast (Includes Items 11, 12, 16, 17, 17a) (1450-1800 PSI)	4	6063	3	Hex Head Tapping Screw — #10-24 x 5/8"
	7052	1	Hydraulic Pump Assembly (MTE) (6" Commercial) (2050-2200 PSI)	70	5839	1	Angling Valve Gasket & O-Ring "KIT" * (Not Shown)
8	A5819	1	Motor Assembly — 4"	71	6506	1	Manifold Gasket
9	8577	1	Flange w/Bearing & Seal	72		2	O-Ring — 015
10	8578	1	Oil Seal Only	40	5833	1	O-Ring — 008
11	5820	1	Suction Filter	73	6580	1	Shim Spacer — .0005" (Silver) Option
	7053	1	Suction Filter (Die Cast Pump)		6581	1	Shim Spacer — .00035" (Clear) Option
12	5821	1	O-Ring — 115	74		1	O-Ring — 010
13	5822	1	Gasket	75	5840	1	Cover Gasket
14	90177	2	Capscrew — 7/16"-14 x 1-1/2" — Grade 5	77	A4950-25	1	Crossover Relief Valve — 2500 PSI** w/O-Rings
15		3	Lock Washer — 7/16" External		A4850-40	1	Crossover Relief Valve — 4000 PSI** w/O-Rings
16		2	Capscrew — 5/16"-18 x 2-3/4"	78	A5044	1	O-Ring Kit **
	90073	2	Capscrew — 5/16"-18 x 2-1/4" — Gr. 5 (Die Cast Pump)	79	3721	1	Back-Up Ring — 015
17	90360	2	Lock Washer — 5/16"	80	3714	1	O-Ring — .58 ID x .06 W
	90608	2	Belleville Spring Washers (Die Cast Pump)	81	3718	2	Back-Up Ring — 013
17a		2	Flat Washer — 1/4" Standard (Die Cast Pump)	82	3719	1	O-Ring — .44 ID x .06 W
18	5783	1	Packing Nut — 1-1/2" Ram	83	3712	1	O-Ring — .765 ID x .097 W
	6998	1	Packing Nut — 2" Ram	85	6529	1	Cushion Valve Kit — * (Includes 2 Sets) (Pressure determined by adjustment)
20	339	1	Packing Set — 1-1/2" Ram	40	5833	2	O-Ring — 008
	3623	1	Packing Set — 2" Ram	74		2	O-Ring — 010
21	341	1	Wiper Ring — 1-1/2" Ram	87	A5929	1	Single Lever Control w/90" Cables
	3624	1	Wiper Ring — 2" Ram		A5785	1	Single Lever Control w/108" Cables
22	338	1	Special Washer — 1-1/2" Ram	88		1	Body w/Label
	3621	1	Special Washer — 2" Ram	89	6065	1	Centering Spring
23	5509	1	Plunger — 1-1/2" x 8" Ram w/Retainer Ring	90		1	Spring Retainer
	336	1	Plunger — 1-1/2" x 10" Ram w/Retainer Ring	91	6584	1	Platen Assembly
	6994	1	Plunger — 2" Ram w/Retainer Ring	92		1	Pivot Platen
24	8332	1	Retainer Ring — 1-1/2" Ram	93	6064	1	Contact Strip
	6997	1	Retainer Ring — 2" Ram	94		2	Ball Stud
25	5823	1	O-Ring — 216	95		1	Hex Head Thread Forming Screw — #10 x 3/8" Hi-Lo
26	5824	1	Base Lug	96	A5841	1	Bottom Cover Assembly
	6999	1	Base Lug (6" Commercial)	97		1	Bottom Cover
27		2	Socket Head Pipe Plug — 1/4"	98		1	Detent Spring
28	5826	1	Lift Valve w/O-Rings	99		1	Contact Tube Assembly
29	5827	2	O-Ring — 012	100		1	Hex Head Thread Forming Screw — #6 x 3/8" Hi-Lo
30	90359	4	Lock Washer — 1/4"***	101		1	Retaining Ring — 3/8"
32	5828	1	Shuttle	102	5900	8	Hex Head Thread Forming Screw — #8 x 5/8" Hi-Lo
33	A5829	1	Check Valve Assembly w/O-Rings	103	A5842	1	Knob & Lever Assembly
29	5827	1	O-Ring — 012	104	6528	1	Lens Label
35	5831	1	O-Ring — 112	105	5857	1	Lockspool w/Label
36		1	Jam Nut — 5/8"-18	40	5833	1	O-Ring — 008
37	6062	1	Half Dog Point Set Screw — #10-24 x 3/8"	106	5931	1	Cable w/Clip & O-Ring (90")
38		1	Socket Pipe Plug — 1/8"		5843	1	Cable w/Clip & O-Ring (108")
39	5832	1	Camshaft	115	5930	1	Cable w/Clip & O-Ring (Adjustable 90")
40	5833	1	O-Ring — 008		5844	1	Cable w/Clip & O-Ring (Adjustable 108")
35	5831	1	O-Ring — 112	74		1	O-Ring — 010 (Fits All Cables)
42	5836	1	Hub Nut	107	4418	1	Ball Stud Retainer Clip (Fits All Cables)
43		1	Valve Lever	108	5803	2	Tapping Screw — #10 x 1"
44		1	Lock Washer #6 — External				
45		1	Pan Head Machine Screw — #6-32 x 1/4"				
46	5837	1	Cover Gasket				
47	6572	1	Valve Cover Plate				
48	90691	1	5/16-18 x 1/2" Capscrew				
49	90692	2	5/16" Ex Tooth Lockwasher				
50							
51							
52		1	Pipe Plug — 3/8"				
53	5798	1	Grounding Cable — 60" — 6 Ga. (Black)				
54	5797	1	Battery Cable — 60" — 4 Ga. (Red)				
55	5799	1	Battery Cable — 22" — 4 Ga. (Red)				
58	5794	1	Solenoid Switch				

**FOR COMPACT TRUCKS**

**NOTE:** BEFORE BEGINNING THE HYDRAULICS INSTALLATION, ALL OF THE ATTACHMENTS, INCLUDING THE HEADGEAR AND LIFT ARM, MUST BE INSTALLED ON THE VEHICLE.

**1. HYDRAULICS ASSEMBLY**

**A.** USING A BENCH VISE TO HOLD THE 32" H.P. HOSE (8) ATTACH ONE 1/4" BRASS BAR STREET ELL (13) TO HOSE. ATTACH THE MALE HALF OF THE DISCONNECT ASSEMBLY (10) TO THE BRASS ELL. PLACE THE 22" H.P. HOSE (9) IN THE BENCH VISE AND ATTACH THE FEMALE HALF OF THE DISCONNECT ASSEMBLY (10) DIRECTLY TO THE HOSE.

**B.** USING A BENCH VISE TO HOLD ANGLE CYLINDERS (4), REMOVE CLOSURES FROM PORTS. SCREW BRASS FORGED STREET ELL (14) INTO PORTS. WHEN TIGHT, ELLS SHOULD BE PARALLEL TO CYLINDER AND POINTING TOWARDS LIVE END. INSTALL 32" H.P. HOSE WITH MALE DISCONNECT HALF TO ELL IN ONE CYLINDER. THIS BECOMES THE PASSENGER'S SIDE CYLINDER. INSTALL THE HOSE WITH THE FEMALE DISCONNECT HALF TO THE REMAINING CYLINDER. THIS WILL BE THE DRIVER'S SIDE CYLINDER. INSTALL CYLINDERS TO A-FRAME AND BLADE ON THEIR RESPECTIVE SIDES SO THAT ELLS ARE ON THE TOP SIDE OF CYLINDER. SECURE CYLINDERS WITH ANCHOR PINS (6) AT PORT END AND RAM END. SECURE ANCHOR PINS WITH COTTER PINS (7).

**C.** INSTALL THE FISHER ELECTRIC HYDRAULIC PAK (EHP) (1) TO THE VEHICLE BETWEEN THE BASE OF THE HEADGEAR AND THE ATTACHING EARS ON THE BOTTOM SIDE OF THE LIFT ARM. CONNECT TO HEADGEAR AND LIFT ARM WITH CLEVIS PINS (5), AND COTTER PINS (7).

**D.** SEPARATE THE REMAINING DISCONNECT ASSEMBLY (10) AND INSTALL A 1/4" HEX NIPPLE (12) AND DUST PLUG (11) TO EACH HALF. REMOVE CLOSURES FROM UPPER AND LOWER ANGLE PORTS ON THE EHP AND INSTALL FEMALE HALF OF DISCONNECT TO UPPER PORT (PASS. SIDE) AND MALE HALF TO LOWER PORT (DRIVER'S SIDE).

**2. SINGLE LEVER CONTROL AND CABLE INSTALLATION**

**A.** DRILL THREE 5/8" HOLES IN FIREWALL FOR CONTROL CABLES AND WIRING HARNESS USING DRILLING GUIDE AS A REFERENCE ONLY. BE SURE THAT BOTH SIDES OF FIREWALL ARE CLEAR OF WIRES OR ANY OTHER OBSTRUCTIONS BEFORE DRILLING. (REFER TO DASH BRACKET KIT FOR DRILLING AND DASH BRACKET MOUNTING INSTRUCTIONS FOR YOUR SPECIFIC VEHICLE).

**B.** CONNECT CONTROL HEAD ADAPTOR BRACKET (3) TO CONTROL HEAD ASSEMBLY (2) WITH FOUR #8 X 5/8" HEX HEAD SELF TAPPING SCREWS (30). ROUTE THE TWO CONTROL CABLES OUT THROUGH THE 5/8" HOLES IN THE FIREWALL, ALONG THE INNER FENDERWELL, TO THE FRONT OF THE VEHICLE. CONNECT THE ADAPTOR BRACKET WITH CONTROL HEAD TO THE DASH BRACKET. INSTALL RUBBER GROMMETS (25) AROUND CABLES WHERE THEY PASS THROUGH FIREWALL.

**C.** ROUTE THE CONTROL CABLES OUT BETWEEN THE RADIATOR AND THE RADIATOR WEB THEN OUT THROUGH THE GRILL LEFT OF THE CENTER OF VEHICLE TO THE EHP. IF THERE ISN'T A CONVENIENT SPOT TO ROUTE THE CABLES OUT PAST THE RADIATOR, DRILL TWO 5/8" HOLES THROUGH THE RADIATOR WEB AND INSTALL RUBBER GROMMETS (25) AROUND CABLES WHERE THEY PASS THROUGH WEB. THE CABLES SHOULD RUN IN AS SMOOTH A PATH AS POSSIBLE, ANY EXTRA LENGTH IN THE CABLES SHOULD BE TAKEN UP WITH A LARGE LOOP OR LOOPS IN THE ENGINE COMPARTMENT. SLIP HOSE GROMMET (26) ON OVER CABLES FOR PROTECTION WHERE THEY PASS THROUGH GRILL OR RADIATOR WEB.

**D.** TO INSTALL THE LIFT CABLE, REMOVE THE RECTANGULAR VALVE COVER PLATE AND GASKET FROM THE EHP (4 SCREWS). APPLY SOME PERMATEX OR OTHER NON-HARDENING SEALER AROUND THE O-RING OF THE CABLE. INSERT THE CABLE INTO THE HOLE ABOVE THE RECTANGULAR OPENING UNTIL YOU CAN PLACE THE SPADE END OF THE CABLE OVER THE VALVE LEVER PIN. OFTEN, THIS CAN BE DONE BY ROTATING THE CABLE SO THE SPADE IS PARALLEL TO THE LEVER. INSERT THE CABLE THE REST OF THE WAY INTO ITS HOLE AND SECURE WITH THE SPECIAL DOG POINT SET SCREW.

**NOTE:** BE SURE THE SET SCREW ENTERS THE TOP GROOVE IN THE CABLE. REPLACE THE RECTANGULAR COVER AND GASKET WITH THE FOUR SCREWS. .

**E.** TO INSTALL THE ANGLE CABLE, REMOVE THE PENTAGON SHAPED COVER (3 SCREWS) FROM THE ANGLE VALVE. CONNECT CABLE AS ABOVE BUT LEAVE THE DOG POINT SET SCREW JUST LOOSE ENOUGH TO ROTATE THE BASE END OF THE CABLE FITTINGS. ACTUATE THE SINGLE LEVER CONTROL TO THE FULL LEFT AND RIGHT POSITIONS THEN RETURN IT TO CENTER AND LOCK IN PLACE. ADJUST CABLE AND FITTING TO ALIGN THE VALVE LEVER PIN TO THE CENTERING SPRING ROLL PIN AND VALVE LEVER ATTACHING SCREW (3 POINT ALIGNMENT). RELEASE LOCK ON CONTROL HEAD. FOR FINAL ADJUSTING PROCEDURE SEE OPERATION PARAGRAPH.

**F.** FASTEN CONTROL CABLES TO INNER FENDER WELL MIDWAY BETWEEN FIREWALL AND RADIATOR WEB WITH CABLE CLAMPS (28). DRILL A 9/64" HOLE AND FASTEN CABLE CLAMP TO INNER FENDER WITH A #10 X 1" SELF TAPPING SCREW (29).

### **3. ELECTRICAL CONNECTIONS**

**A.** LOCATE THE EHP SOLENOID (20) WITHIN 18" OF THE VEHICLE BATTERY. USING THE TWO HOLES IN THE SOLENOID AS A GUIDE, MARK AND DRILL TWO 9/32" HOLES, AND FASTEN WITH TWO 1/4" X 3/4" CAPSCREWS (31), FLATWASHERS (32) AND LOCK NUTS (33). CONNECT ONE END OF THE 22" #4 CABLE (23) TO ONE OF THE LARGE TERMINALS ON THE SOLENOID. ROUTE THE OTHER END OF THE CABLE FORWARD TO THE BATTERY AND CONNECT IT TO THE POSITIVE TERMINAL. CONNECT ONE END OF THE RED 60" #4 CABLE (21) TO THE OTHER LARGE TERMINAL ON THE SOLENOID. ROUTE THE END OF THIS CABLE OUT THROUGH THE GRILL AND CONNECT IT TO THE MOTOR TERMINAL ON THE EHP. CONNECT ONE END OF THE BLACK 60" #6 GROUND CABLE (22) TO THE GROUND CONNECTION (THREADED HOLE) ON THE SIDE OF THE ISARMATIC UNIT WITH A 5/16-18 X 1/2 CAPSCREW (35) AND THE LOCKWASHER (34). ROUTE THE OTHER END BACK THROUGH THE GRILL ALONG WITH THE MOTOR WIRE TO THE ENGINE COMPARTMENT AND CONNECT IT TO THE ENGINE GROUND TERMINAL OR OTHER CONVENIENT GROUND LOCATION.

B. FISHER ENGINEERING RECOMMENDS THAT THE SOLENOID CIRCUIT (ACTIVATED BY THE SINGLE LEVER CONTROL HEAD SWITCH) BE CONNECTED TO A POWER SOURCE THAT IS ENERGIZED ONLY WHEN THE VEHICLE IGNITION SWITCH IS "ON". SEE VEHICLE OWNERS MANUAL OR SERVICE MANUAL FOR PROPER INSTALLATION POINT OF POWER TAP TO ELECTRICAL SYSTEM. CUT THE SHORT WIRE LOOP ON THE FUSE HOLDER (15) IN HALF AND CONNECT ONE SIDE TO POWER SOURCE WITH APPROPRIATE CONNECTOR (17,18,19) AS MENTIONED ABOVE. INSERT ONE END OF THE #16 WIRE (37) IN THROUGH THE FIREWALL ALONG WITH ONE OF THE CONTROL CABLES. USING A #16 BARREL CONNECTOR (38) ATTACH THIS WIRE TO THE OTHER END OF THE FUSE HOLDER WIRE. LEAVE JUST ENOUGH WIRE INSIDE THE CAB TO POSITION THE FUSE HOLDER OUT OF THE WAY. ROUTE THE CONTROL HEAD WIRE OUT TO THE ENGINE COMPARTMENT ALONG WITH THE OTHER CONTROL CABLE. ROUTE THIS WIRE ALONG WITH THE FUSE HOLDER WIRE TO THE SOLENOID. CUT BOTH WIRES TO LENGTH, STRIP ENDS AND CRIMP ON #16 EYE TERMINALS (16). CONNECT WIRES TO THE TWO SMALL TERMINALS. (EITHER WIRE CAN GO ONTO EITHER TERMINAL.) WHEN FINAL ELECTRICAL CONNECTION IS COMPLETE, RECONNECT BATTERY TERMINALS. CHECK ALL FITTINGS, CAPSCREWS AND NUTS FOR TIGHTNESS. SECURE WIRES WITH NYLON TIE WRAPS (27) AND PLACE OPERATING DECAL (24) ON DASH.



# TROUBLESHOOTING AND TUNE-UP GUIDE A6125

Cab Control Position	PROBLEM DESCRIPTION	DEFINE PROBLEM AND FOLLOW STEPS BELOW.					
Angle	Blade will not angle or angles too slow. Time: 1½" dia. cylinders — 4 seconds 2" dia. cylinders — 8 seconds	Check if motor runs, if not, see Electrical Diagnosis B	Check oil level. (Page 8)	Verify 4-way valve lever travel. See C.	Adjust lift valve out. See E1.	Check Quick Couplers & Angling Cylinder Packings	Remove Pump. Clean filter screen.
Raise	Blade will not raise or raises too slow. Time: 1½" x 8" lift ram — 2 seconds 1½" x 10" lift ram — 3 seconds 2" x 6" lift ram — 4 seconds			Verify 3-way valve lever travel. See C.	Adjust lift valve in. See E1.	Check lift ram packing nut.	
Neutral	Blade will not remain angled while plowing.	Adjust cushion valves. See A.					
Neutral	Motor continues to run in neutral.	Disconnect cab control wire from solenoid.	If motor runs, solenoid is shorted. Replace solenoid. If motor stops, short is in primary (cab control) circuit. Isolate and repair.				
Angle	Blade raises while angling.	Verify 3-way valve lever travel. See C.	Adjust lift valve (out). See E1.		<b>FURTHER TROUBLESHOOTING REQUIRES THE USE OF TEST EQUIPMENT.</b>  <b>RETURN UNIT TO FACTORY</b>		
Neutral	Blade lowers in neutral.		Adjust check valve (out). See E2.	Remove check valve. Inspect O-ring & seat.			
Lower	Blade lowers too fast.						
Lower	Blade will not lower or lowers too slow.		Adjust check valve (in). See E2.	Check lift ram packing nut.			

## GENERAL INFORMATION

Most service can be performed with the hydraulic unit left on the vehicle. This should be done whenever possible because it permits evaluation of the entire system (vehicle electrical system, cables, cab control, etc.) as well as saving time.

Be sure to disconnect the negative battery terminal before removing the motor, solenoid or cab control.

**CAUTION** — Do not stand between the vehicle and plow when it is being raised or angled. **CLEARANCE BETWEEN VEHICLE AND PLOW IS DECREASED AS PLOW IS RAISED OR ANGLED.**

## A CUSHION VALVE ADJUSTMENT

(Applies to 1" block cushion style valves. 2" block cartridge style crossover relief valves are serviced by replacement only).

Tighten cushion valve stem as much as possible (until spring is fully compressed). Then, back off valve stem (rotate counterclockwise) the number of turns specified.

CYLINDER STROKE		CROSSOVER RELIEF PRESSURE	NUMBER OF TURNS
LIFT	ANGLE		
6"	10"	2500	1-3/4

**PACKING NUT ADJUSTMENT** — EHP or Angling Cylinders. If leaking, tighten packing **NOT MORE THAN 1/4 TURN AFTER YOU FEEL PACKING NUT CONTACT PACKINGS.** Over-tightening affects cylinder operation and packing life.

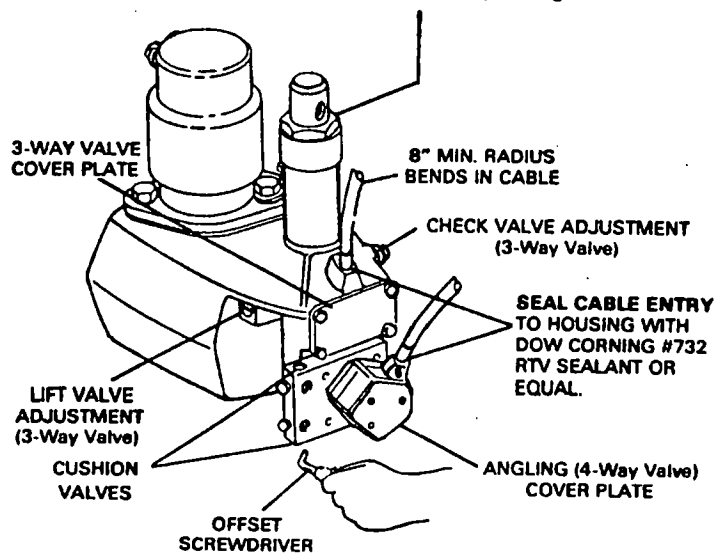

**NOTE:** Manufacturer assumes no liability for accidents or damages notwithstanding the fact that suggestions have been followed.

## B ELECTRICAL DIAGNOSIS

Condition — EHP motor does not run with cab control in "raise" or "angle" positions and ignition key is on. (Battery has sufficient charge to start engine.)

1. Check all electrical cables and connections. Clean and tighten as required.

See **WARNING ON PAGE 2 BEFORE PROCEEDING.**

2. Attach 16 ga. or heavier jumper wire from positive post of battery to solenoid small terminal with wire from fuse. Operate cab control in raise and both angle positions. If motor runs, problem is in power supply to solenoid. Check in-line fuse and wires. If motor does not run. . .
3. Turn Ignition key ON. Use above jumper wire to ground solenoid small terminal with black wire from cab control. If motor runs, problem is in cab control. Check for broken wire, loose connection or bent contact in cab control. Check if cab control is grounded through push-pull cables. If motor does not run. . .

4. Use heavy jumper cable to by-pass the secondary (large) terminals of the solenoid. If motor runs, the solenoid is defective. If motor does not run. . .
5. Disconnect battery ground cable. Remove motor and check pump shaft. If tight, repair/replace pump. If loose, motor is defective.

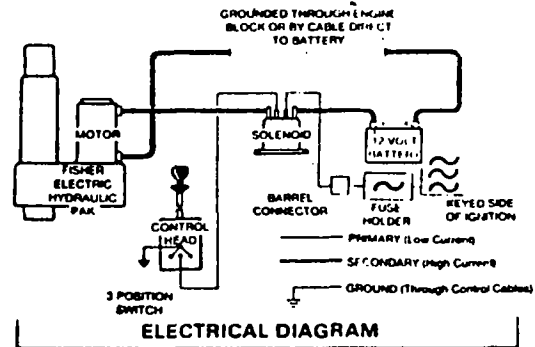

## C

### 3 WAY/4 WAY VALVE TRAVEL

1. Disconnect angling hoses and lift chain.
2. Remove 3-way (lift valve) or 4-way (angle valve) cover plate. Activate cab control in all directions and observe valve lever travel and positions. Lock the cab control in center position with the locking spool. Both valve levers should be in the neutral position as shown.

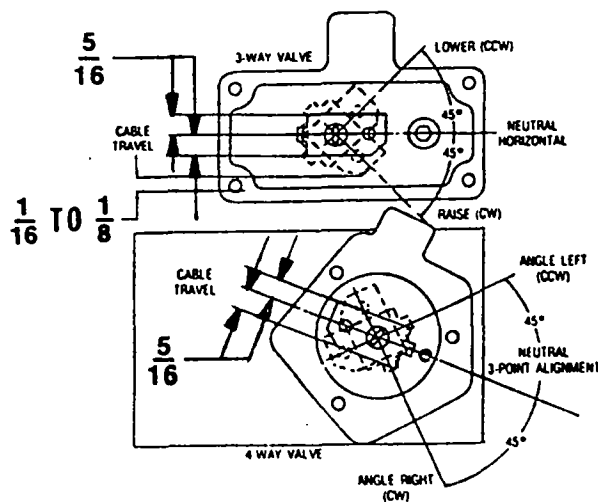

### POSSIBLE CAUSE OF INADEQUATE TRAVEL OR INCORRECT VALVE LEVER POSITIONS.

1. Dirt, or ice buildup in enclosure.
2. Cables disconnected in valve enclosure or in cab control.
3. Binding, kinked or broken cable. (8" minimum radius)
4. Set-screw not in groove in cable.
5. Cable out of adjustment or insufficient ring/rotor clearance (4-way valves only).
6. Lift valve too far in (3-way valve only). See E1.

## D

### 4-WAY (ANGLE) VALVE ADJUSTMENT

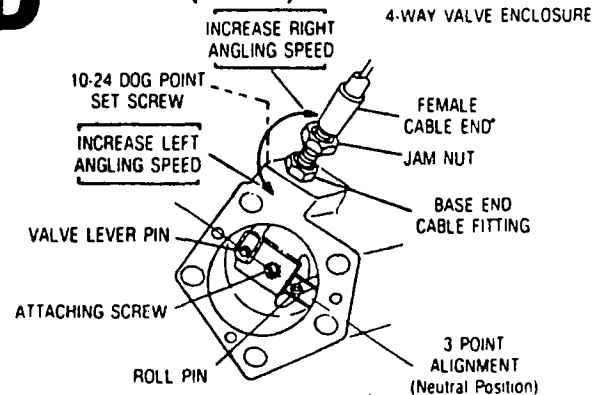

## E1

### 3-WAY (RAISE-LOWER) VALVE ADJUSTMENT (SENSITIVE ADJUSTMENTS - MAX 1/8 TURN AT A TIME)

## E2

#### LIFT VALVE ADJUSTMENT

Disconnect plow before adjusting. If plow will not raise or raises too slowly, turn (CW). If plow raises while angling or angles too slowly, turn out (CCW).

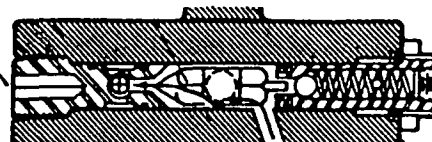

#### CHECK VALVE ADJUSTMENT

If plow will not lower or lowers too slowly, turn in (CW). If plow lowers too fast, turn out (CCW). Hold check valve while loosening or tightening jam nut. To prevent O-ring from blowing out, loosen jam nut 1/4 turn max.

### INITIAL ADJUSTMENT (IF VALVES HAVE BEEN DISTURBED OR REMOVED)

#### LIFT VALVE

Remove cable from pin and place valve lever in neutral position (see C). Turn lift valve in until it is flush to the casting surface. Rotate lever to the "raise" position. It should stop 1/16 to 1/8" from enclosure bottom. If not, turn valve in or out until this dimension is obtained.

#### CHECK VALVE

Turn check valve in until three (3) full threads protrude from the jam nut with jam nut bottomed on housing.

# INSPECTION AND ROUTINE SERVICE

## GENERAL

Scratching, denting or marring machined surfaces can make parts unserviceable. Cleanliness is essential when servicing the unit.

The following recommendations are intended as a general guide for regular care and maintenance. Operating under adverse conditions or sustained loads requires more frequent servicing.

## CHECKLIST

1. Check oil level with unit on vehicle and ram collapsed. If low, fill to top of reservoir fill hole, located at rear of housing.

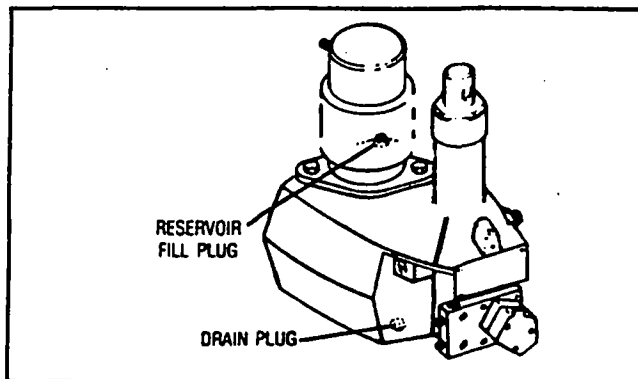

### NOTE:

Be sure to fill through reservoir fill hole. Never fill through motor/pump opening if, for instance, motor has been removed for servicing. Filling through motor/pump hole can cause overfilling and damage entire unit.

Use automatic transmission fluid. If that is not available, you may also use SAE 10W nondetergent motor oil (SAE 5W in extreme cold).

Capacity of the system is summarized in the following chart. Note that the system holds less if angling cylinders and hoses have not been drained.

CYLINDER STROKE		CAPACITIES	
LIFT	ANGLE	EHP RESERVOIR ONLY	TOTAL (w/HOSES & CYL)
6"	10"	1½ QT.	2¼ QT.
10"	12"	1½ QT.	2¼ QT.
6"	16"	1½ QT.	2¼ QT.

2. Drain and flush the hydraulic reservoir at the end of each plowing season. Use the drain plug located in the bottom front of the reservoir.
3. If rams are leaking excessively, tighten packing nuts. Do not tighten more than 1/4 turn after you feel the nut contact the packings. If leak continues, replace packings and wiper ring in nut. Over-tightening affects cylinder operation and packing life.
4. Check 3-way and 4-way valves for excessive oil leaks. Replace O-rings if they are damaged.
5. Periodically clean and tighten all electrical connections.
6. At beginning of plowing season, inspect and test battery. Recharge or replace, if necessary. Suggested MINIMUM vehicle electrical system: 70 amp hr./550 CCA Battery, 55 amp Alternator.
7. The pump inlet filter screen should be cleaned whenever the pump is removed. If the screen is damaged, replace it.

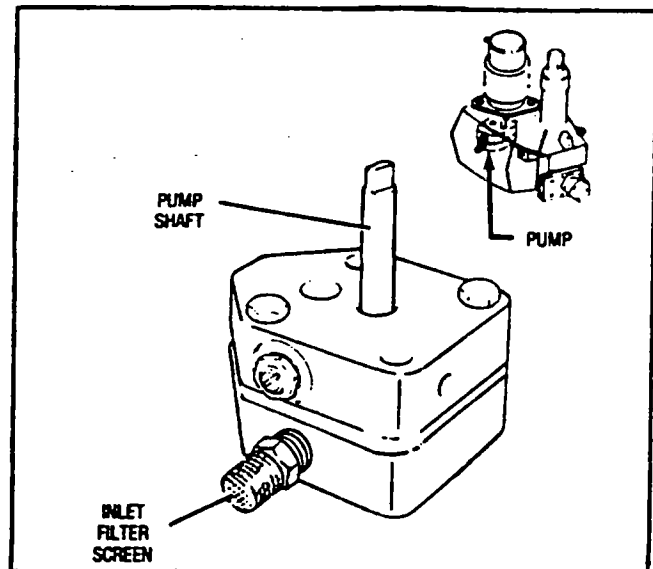

8. During periods of inactivity, leave the EHP lift ram collapsed. This will prevent damage to the surface of the plunger. Also, coat the exposed surfaces of the angling cylinders with grease to prevent rust or corrosion.