



PARTS & INSTALLATION INSTRUCTIONS MEYER MDII™ SNOW PLOW MOUNTING 1999 & Later GMC and Chevrolet K 1500 Series 4x4 Models

IMPORTANT NOTICE

End user must be given this instruction sheet prior to delivery of this Snow Plow.

The equipment you have just purchased should only be used on vehicles equipped with the Manufacturer's Snow Plow Preparation Packages. Snow Plowing without the original Snow Plow Preparation Package may damage your vehicle and the added weight to the equipment may impair the operation and control of the vehicle. Snow Plowing with a vehicle that the manufacturer does not recommend for that purpose may void your new vehicle warranty. If your vehicle is not originally equipped with the Snow Plow Package, additional parts may be necessary before snow plowing. Owners of these vehicles should consult their dealers before purchase or installation of such parts. CAUTION: the installation, on any vehicle, of these parts is not a full substitute for the original equipment Snow Plow Preparation Package.

Warning: Lift Arm extends beyond bumper of vehicle. To minimize damage from a front-end collision, Lift Arm should be removed from vehicle when Snow Plow is removed.

Parts List

Item	Part No.	Qty	Description
	17121	1	MOUNTING CARTON
1	11819	1	• L.H. Side Mount
2	11820	1	• R.H. Side Mount
3	11825	1	• Underframe Weld
4	22223	1	• Handle Bolt, Washer
	08734	1	• HARDWARE BAG
5	22280	4	• Handle Bolt, Washer
6	11669	2	•• Sleeve
7	20141	2	•• Bolt H 5/8-11 x 2" Gr. 5
8	20096	12	•• Bolt H 1/2-13 x 1-3/4" Gr.5
9	20109	2	•• Bolt H 1/2-13 x 6" Gr.5
10	20355	18	•• Flatwasher 1/2"
11	20357	8	•• Flatwasher 5/8"
12	20307	18	•• Locknut Esna 1/2-13
13	20309	3	•• Locknut Esna 5/8-11
	21976	2	•• Battery Connectors
*	11770	1	Universal Clevis (Packed in CLF Carton)
11" Sector		MEYER	
	Part No.	Qty	Description
	16515	1	Sector A-Frame Carton
	21534	2	• Lift Chain 5/16 x 36"
	12326	1	• Sector
	13711	1	• A-Frame (11" x 34" x 22-1/4")
	07017	3	• Trip Spring
	09916	1	• Plow Marker kit
	08738	1	• Hardware Bag
DIAMOND			
	81504	1	Common Attaching Kit
	817000104	2	• Cylinder Collar
	8511002008059	1	• Chain 5/16" PR Coil Lift 59"
	811000095	2	• Plow Marker
	80389	1	• Hardware Bag
	81026	1	Push Frame

Parts indented are included in the carton, bag or assembly under which they are indented.

Meyer Products and Diamond Equipment reserves the right, under its continuing product improvement program, to change construction or design details, specifications and prices without notice or without incurring any obligation.

Meyer Products
18513 Euclid Ave. • Cleveland, Ohio 44112-1084
Phone 486-1313 (Area Code 216)
www.meyerproducts.com • email inf@meyerproducts.com



Diamond Equipment
Old Route 1 RR #1 • Damariscotta, ME 04543-9720
Phone 563-2227 (Area Code 207)
www.diamondplow.com • email info@diamondplow.com

General Information

CAUTION: Always disconnect battery before beginning installation.

DO NOT BURN holes or **WELD** vehicle frame. This may cause frame failure.

After first use, retighten all mounting bolt connections to specified torque. All mounting bolt connections to be checked periodically for tightness.

Locknuts are furnished **DO NOT** tighten bolts and nuts until installation is complete (unless otherwise specified), then be sure to tighten all attaching parts per specified torque chart.

SAFETY PRECAUTIONS should be used when **Hydraulic Unit is in OPERATION** and plow is in a **RAISED** position. Lower plow to ground when vehicle is **PARKED**.

NOTE: It is important that the Meyer harness, all wires from the Meyer light switch, and all other electrical wires be routed around hot or moving engine parts, and any sharp metal. Protection must be provided to guard against wire damage at these points. All excess or loose wires must be neatly secured using wire ties.

Check contents against the parts list to determine all are correct and included, and also to familiarize yourself with them.

FOLLOW THESE INSTRUCTIONS EXPLICITLY. Warranty does not apply to a Meyer or Diamond product which has been negligently or improperly assembled or installed.

OVERHAUL and **SERVICE INFORMATION** are covered on separate instructions.

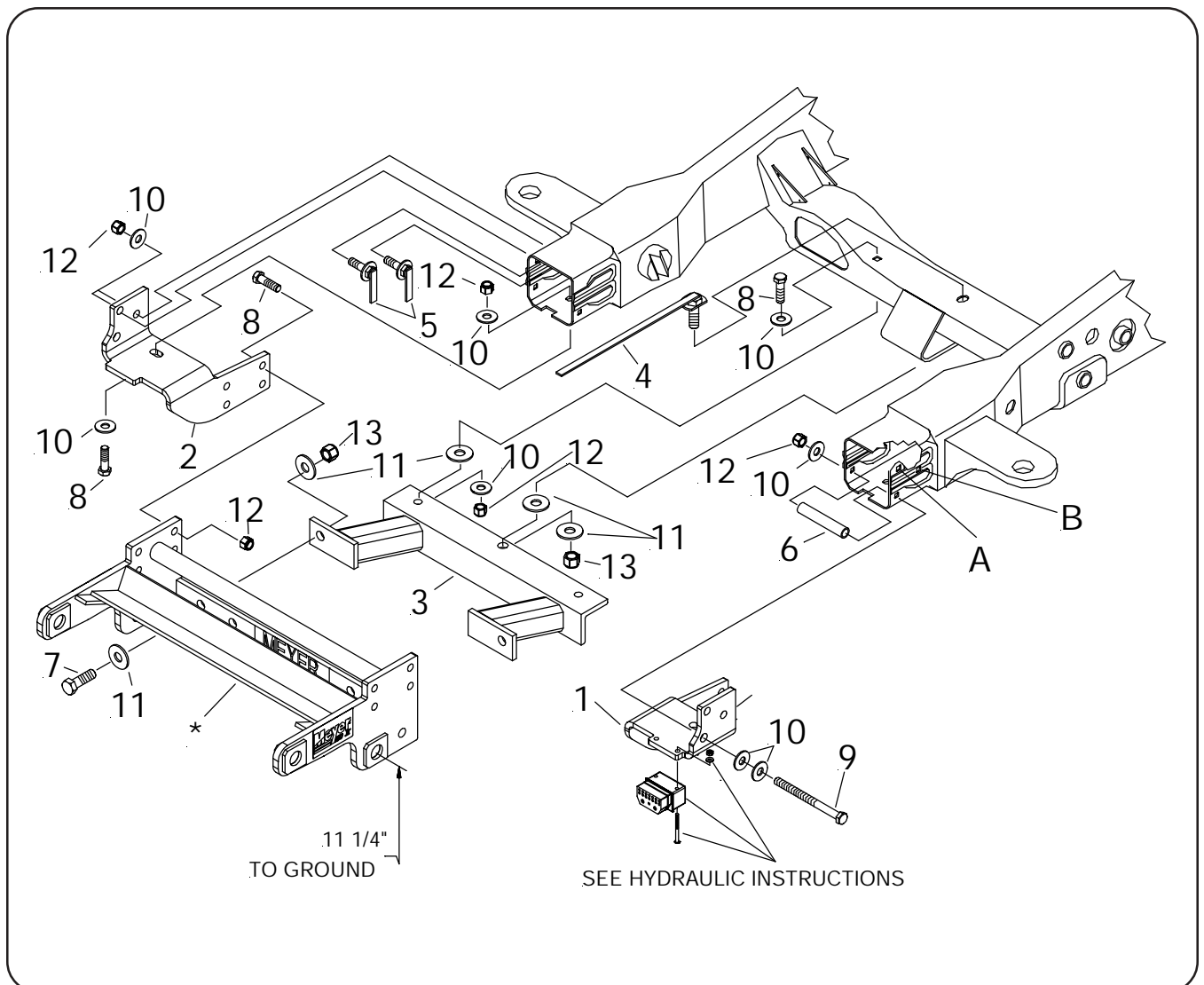

VEHICLE RECOMMENDATIONS

General Motors Corp.

General Motors recommends snowplow usage for only those trucks that have the option "VYU" Snow Plow Preparation Package.

General Motors recommends that when a snow plow is mounted that only one passenger should accompany the driver. More than one passenger may exceed front gross axle weight ratings.

Model - K1500	G.V.W.	Opt.Code	Frnt.	G.V.W.R.
Reg. Cab only				
119" W.B. 1999-cur.	6100 lb.	(C5M)		3925 lb.
133" W.B. 2001-cur.	6400 lb.	(C7H)		3925 lb.

Vehicles Not Recommended:

1500 Extended Cab Pickups
 1500 Chevy Avalanche
 1500 Chevy Tahoe/Suburban
 1500 GMC Yukon/Yukon Denali
 1500 GMC Sierra Denali (AWD)
 Cadillac Escalade/ Escalade EXT

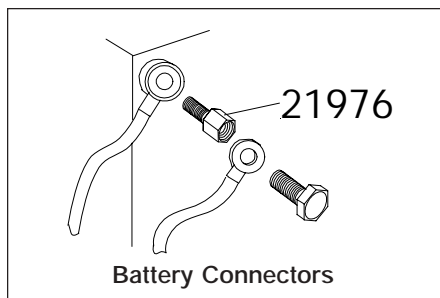

TORQUE CHART FOOT LBS.

Bolt Nut Size	Gr. 2	Gr. 5	Gr. 8
1/4 - 20	4 - 5		
5/16 - 18	9 - 11		
3/8 - 16	17 - 20	26 - 29	
7/16 - 14		42 - 46	60 - 66
1/2 - 13		64 - 72	90 - 100
5/8 - 11		127 - 141	179 - 198
3/4 - 10		227 - 251	

Meyer Products or Diamond Equipment assumes no responsibility for installations not made in accordance with these instructions.

INSTALLATION INSTRUCTIONS

- A. Remove air dam. Retain all hardware. The air dam may be reinstalled.
 - B. Remove splash shield. Retain. It will not be reused. Hardware will not be reused.
 - C. Remove tow hooks from both driver and passenger side frame rails. Retain, they will not be reused. **NOTE: On some GMC models removal of the bumper may be necessary.**
 - D. Position the L.H. & R.H. Side Mounts (1&2) to the bottom flange of vehicle frame and align holes to where tow hook bolts were removed. Attach Side Mounts to bottom tow hook hole under the rails with 1/2-13 x 1-3/4" bolts (8), 1/2" flatwashers (10), and 1/2-13 locknuts (12). Attach front holes of Side Mounts using 1/2-13 x 6" bolts (9), 1/2" flatwashers (10), sleeves (6), and 1/2-13 locknuts (12). **Note: Snug all bolts during the installation. Do not torque down any bolts until step I.**
 - E. Using the Side Mounts as templates, drill two 9/16" holes at "A" and "B" on the outside of each frame rail only. **Notes: Hole "A" may be on some frames from the factory. Optional fog lamps may need to be removed during drilling.** Remove 1/2-13 x 6" bolts (9), 1/2" flatwashers (10), sleeves (6), and 1/2-13 locknuts (12). Attach holes "A" and "B" using Handle Bolt/Washers (5), 1/2" flatwashers (10), and 1/2" locknut (12). Reinstall the 1/2-13 x 6" bolts (9), 1/2" flatwashers (10), sleeves (6), and 1/2-13 locknuts (12). Do not tighten at this time.
 - F. Attach the Universal Clevis (*) between the LH & RH Side Mounts (1&2) using four 1/2-13 x 1-3/4" bolts (8), and 1/2" locknuts (12) on each side.
 - G. Position underframe (3) behind the universal clevis frame's bottom angle. Attach underframe (3) to the Universal Clevis (*), using 5/8-11 x 2" bolts (7), 5/8 flatwashers (11), and 5/8-11 locknuts (13).
 - H. Attach rear of underframe (3) to the three holes in the vehicle crossmember. All bolts must be installed thru the tear drop shaped opening on either side of vehicle crossmember. Attach to the outer two holes in vehicle crossmember using 1/2-13 x 1 3/4" bolts (8), 1/2 flatwashers (10), and 1/2-13 locknut (12), and at the center hole using handle bolt (4), 5/8" flatwasher (11), and 5/8-11 locknut (13).
- Note: Flatwashers (11) should be placed between the crossmember and underframe on all three holes.**
- Note: Before tightening the fasteners, the Clevis Frame (*) should be level with the ground and pushed back as far under the vehicle as possible.**
- I. Tighten all fasteners to their proper torque. Tighten bolts in the same order they were assembled to the vehicle.
 - J. Reinstall bumper if removed. Reinstall air dam if desired, notch out around clevis frame as needed.
 - K. Install remaining snowplow hardware per separate instructions.