



PARTS & INSTALLATION INSTRUCTIONS
MDII™ and EZ MOUNT PLUS™
SNOW PLOW MOUNTING 17128
1992 THRU 1998 FORD F350
PICK-UP 4x4 MODELS

End user must be given this instruction sheet prior to delivery of this Snow Plow.

SAFETY DEFINITIONS

	This is the safety alert symbol. It is used to alert you to potential personal injury hazards. Obey all safety messages that follow this symbol to avoid possible injury or death.
	DANGER Indicates an imminently hazardous situation which, if not avoided, will result in death or serious injury.
	WARNING Indicates a potentially hazardous situation which, if not avoided, could result in death or serious injury.
	CAUTION Indicates an potentially hazardous situation which, if not avoided, may result in minor or moderate injury.
	CAUTION used without the safety alert symbol indicates a potentially hazardous situation which, if not avoided, will result in property damage.

IMPORTANT NOTICE

In conjunction with FMVSS (Federal Motor Vehicle Safety Standards) and OEM (Original Equipment Manufacturer) guidelines, Meyer Products has designed this plow package with the following guidelines:

	Installation of a snowplow may effect your new vehicle warranty. For more information consult your Vehicle Owner's Manual / Vehicle Dealer.
	The vehicle must not be operated when overloaded. In all cases, the loaded vehicle weight, including the entire snowplow system, all aftermarket accessories, driver, passenger, options, nominal fluid levels, and cargo must not exceed the front/rear Gross Axle Weight Rating (GAWR), and total Gross Vehicle Weight Rating (GVWR). These weights ratings are specified on the safety compliance certification label on the driver's side door opening. The use of rear ballast weight may be required to prevent exceeding the front GAWR.

According to the NHTSA (National Highway Traffic Safety Administration) new and untitled vehicles need to be verified by the installer that snowplow and ballast (if needed) do no exceed the front/rear GAWR and total GVWR.

	Read the Meyer Owner's Manual before operating or servicing a snowplow. FOLLOW THESE INSTRUCTIONS EXPLICITLY.
--	--

GENERAL INFORMATION

	SAFETY PRECAUTIONS should be used when Hydraulic Unit is in OPERATION and plow is in a RAISED position. Lower plow to ground when vehicle is PARKED in case of hydraulic failure.
--	---

Check contents against the parts list to determine all are correct and included, and also to familiarize yourself with them.

	Warranty does not apply to a Meyer or Diamond product which has been negligently or improperly assembled or installed.
--	--

	CAUTION: To avoid harm to vehicles electrical system always disconnect battery before beginning installation. DO NOT BURN holes or WELD vehicle frame. This may cause frame failure.
--	---

OVERHAUL and SERVICE INFORMATION are covered on separate instructions.

Meyer Products and Diamond Equipment reserves the right, under its continuing product improvement program, to change construction or design details, specifications and prices without notice or without incurring any obligation.

Meyer Products Inc.
18513 Euclid Ave. • Cleveland, Ohio 44112-1084
Phone 486-1313 (Area Code 216)
www.meyerproducts.com • email info@meyerproducts.com

Diamond Equipment
6 Angell Lane • Damariscotta, ME 04543-4507
Phone 563-2227 (Area Code 207)
www.diamondplow.com • email info@diamondplow.com



PARTS LIST

ITEM	PART NO.	QTY	DESCRIPTION
	17128	1	MOUNTING CARTON
1	11987	1	• L.H. Brace Weldment
2	11988	1	• R.H. Brace Weldment
3	11991	1	• Top Bracket Weldment
4	11396	1	• Brace Connector
5	11525	1	• L.H. Side Member
6	11524	1	• R.H. Side Member
	08768	1	• Hardware Bag
7	11943	2	•• Spacer
8	14744	2	•• Spacer
9	20077	4	•• Bolt H 7/16-14 x 2-1/2" Gr.5
10	22159	8	•• Bolt H 7/16-14 x 2" Gr.8
11	20096	8	•• Bolt H 1/2-13 x 1-3/4" Gr. 5
12	20139	2	•• Bolt H 5/8-11 x 1-1/2" Gr. 5
13	20140	6	•• Bolt H 5/8-11 x 1-3/4" Gr. 5
14	20141	2	•• Bolt H 5/8-11 x 2" Gr. 5
15	20150	2	•• Bolt H 5/8-11 x 4-1/2" Gr. 5
16	20162	2	•• Bolt H 3/4-10 x 1-1/2" Gr. 5
17	20306	12	•• Locknut ESNA 7/16-14
18	20307	8	•• Locknut ESNA 1/2-13
19	20309	10	•• Locknut ESNA 5/8-11
20	20310	2	•• Locknut ESNA 3/4-10
21	20354	16	•• Flatwasher 7/16"
22	20357	2	•• Flatwasher 5/8"
23	20359	2	•• Flatwasher 3/4
24	22135	2	•• Handle Nut
25	22268	4	•• Retaining Washer
*	19370	1	Universal Clevis (Part of Plus CLF Carton)
**	11770	1	Universal Clevis (Part of MDII CLF Carton)
11" Sector		15" Sector	
PART NO.		MEYER	
16515	16516	1	DESCRIPTION
			Sector A-Frame Carton
DIAMOND			
81504		1	Common Attaching Kit
81026		1	Push Frame

Parts indented are included in the carton, bag or assembly under which they are indented.

IMPORTANT

After first use, retighten all mounting bolt connections to specified torque. All mounting bolt connections to be checked periodically for tightness.

Locknuts are furnished **DO NOT** tighten bolts and nuts until installation is complete (unless otherwise specified), then be sure to tighten all attaching parts per specified torque chart.

TORQUE CHART FOOT

Bolt Nut Size	Gr. 2	Gr. 5	Gr. 8
1/4 - 20	4 - 5		
5/16 - 18	9 - 11		
3/8 - 16	17 - 20	26 - 29	
7/16 - 14		42 - 46	60 - 66
1/2 - 13		64 - 72	90 - 100
5/8 - 11		127 - 141	179 - 198

NOTE:

THIS MOUNTING CARTON CAN BE USED WITH THE MDII OR EZ MOUNT PLUS CLF CARTONS.

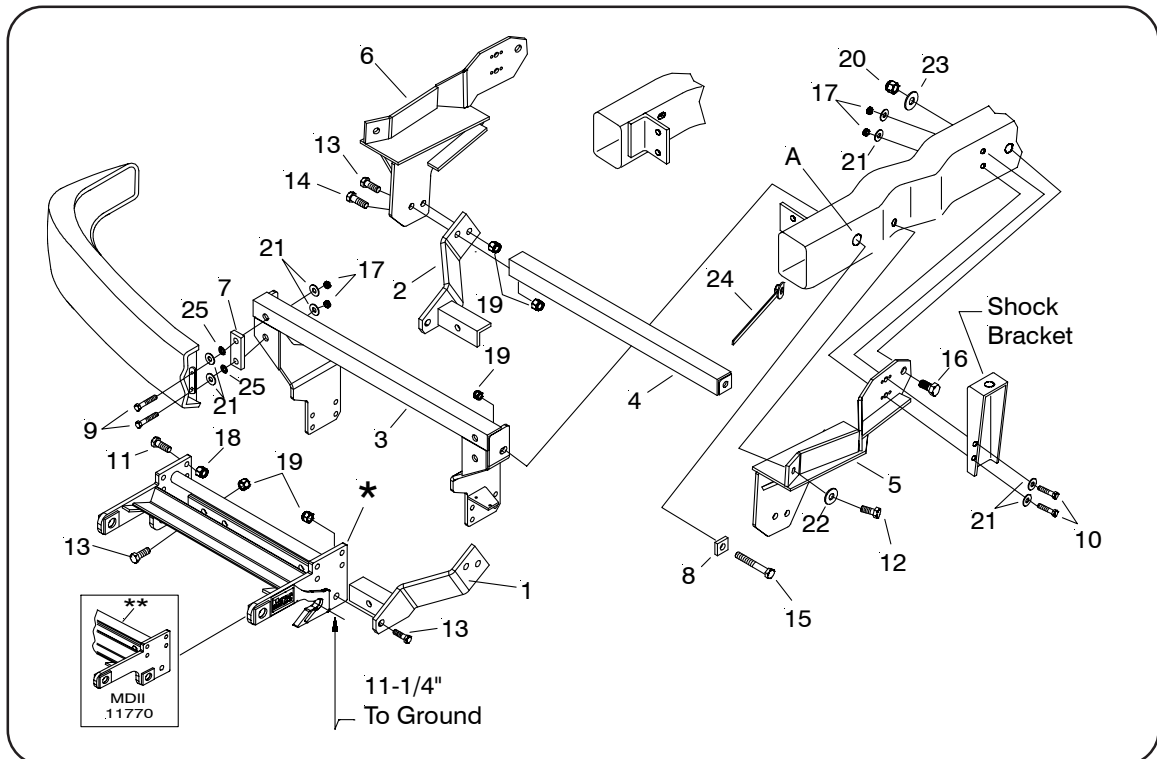

VEHICLE RECOMMENDATIONS

SNOW PLOWS ON NOT RECOMMENDED VEHICLES:

Applying a snowplow to a model shown as "N/R" (not recommended), or to 4X2 models, does not in of itself void the Normal Ford New Vehicle Warranty. However, Warranty may be denied if the addition of occupants in any available seat belt position would result in vehicle overloading. For all models, whether recommended or not, Warranty denial may also occur if damage to any Ford part of vehicle system results from the installation of the after market equipment.

4WD 1992 thru 1998:

F350---4600 lb.Frt. G.A.W.R.

F350 Chassis Cab---5000 lb.Frt. G.A.W.R.

Not recommended :

Super / Crew Cab, Short wheel base models.

Pick up with 7.3L V-8 diesel (99M) engine

▲WARNING

- A ballast weight may be required to prevent front GAWR overloading. If required, ballast must be securely attached at least 24 inches behind the rear axle.

▲WARNING

- Front end wheel alignment and headlight aim may require readjustment after installation of equipment, and is the responsibility of the equipment installer. Failure to adjust front wheel alignment may cause premature uneven tire wear. If required, reset to chassis manufacture's specifications found in the Ford Shop Manual.

Rear ballast is determined by weighing a vehicle's front and rear axles and adding weight behind the rear axle until front axle weight is under or equal to the vehicle specific front GAWR while not exceeding the rear GAWR and GVWR.

Vehicle option packages may vary. If in doubt, it is always a good idea to weigh the vehicle to ensure all weight ratings are not exceeded with plow in the raised position.

Meyer Products or Diamond Equipment assumes no responsibility for installations not made in accordance with these instructions.

INSTALLATION INSTRUCTIONS

- A. Remove bolts from shock absorber brackets. Retain all hardware it will not be re-used.
- B. Position side members (5&6) between vehicle frame and shock absorber brackets. On 1994 and later vehicles, it will be necessary to ream all four of the 5/16" diameter holes in each sidemember to 1/2" diameter. On 1992 and 1993 vehicles, reaming of these holes is not necessary. Attach sidemembers at shock absorber bracket using 7/16-14 x 2" bolts (10), flatwashers (21) and 7/16-14 locknut (17). Attach sidemembers to vehicle frame back hole using 3/4-10 x 1-1/2" bolt (16), flatwasher (23) and locknut (20). Attach front hole using 5/8-11 x 1-1/2" bolt (12), flatwasher (22) and handle nut (24).

Make certain side members are flat against bottom of vehicle frame before tightening to proper torque.

- C. Remove bumper and remove studs from bumper.
- D. Using hole "A" in vehicle frame, position top bracket weldment (3) behind vehicle bumper brackets. Attach to vehicle frame using 5/8-11 x 4-1/2" bolts (15), spacers (8) and locknuts(19). Re-install bumper using 7/16-14 x 2 1/2 bolts (9), 7/16 flatwashers (21), retaining washers (25), spacers (7) and 7/16-14 locknuts (17) as shown in the illustration.
- E. Hang Universal Clevis(*) from top bracket weldment (3) using 1/2-13 x 1 3/4 bolts (11) and 1/2-13 locknuts (18).
- F. Attach brace weldments (1&2) to the Universal Clevis (*) using 5/8-11 x 1 3/4 bolts (13) and locknuts (19). Attach brace weldments to side members (5&6) including brace connector (4) with 5/8-11 x 2 bolts (14) and also using 5/8-11 x 1 3/4 bolts (13) and locknuts (19).

Note: Before tightening the fasteners, the clevis frame should be pushed back as far as possible under vehicle.

- G. Tighten all fasteners to their proper torque. Tighten bolts in the same order they were assembled to the vehicle.