

Parts & Installation Instructions EZ Mount Classic Model DP 7'-6" Drive Pro™ Moldboard

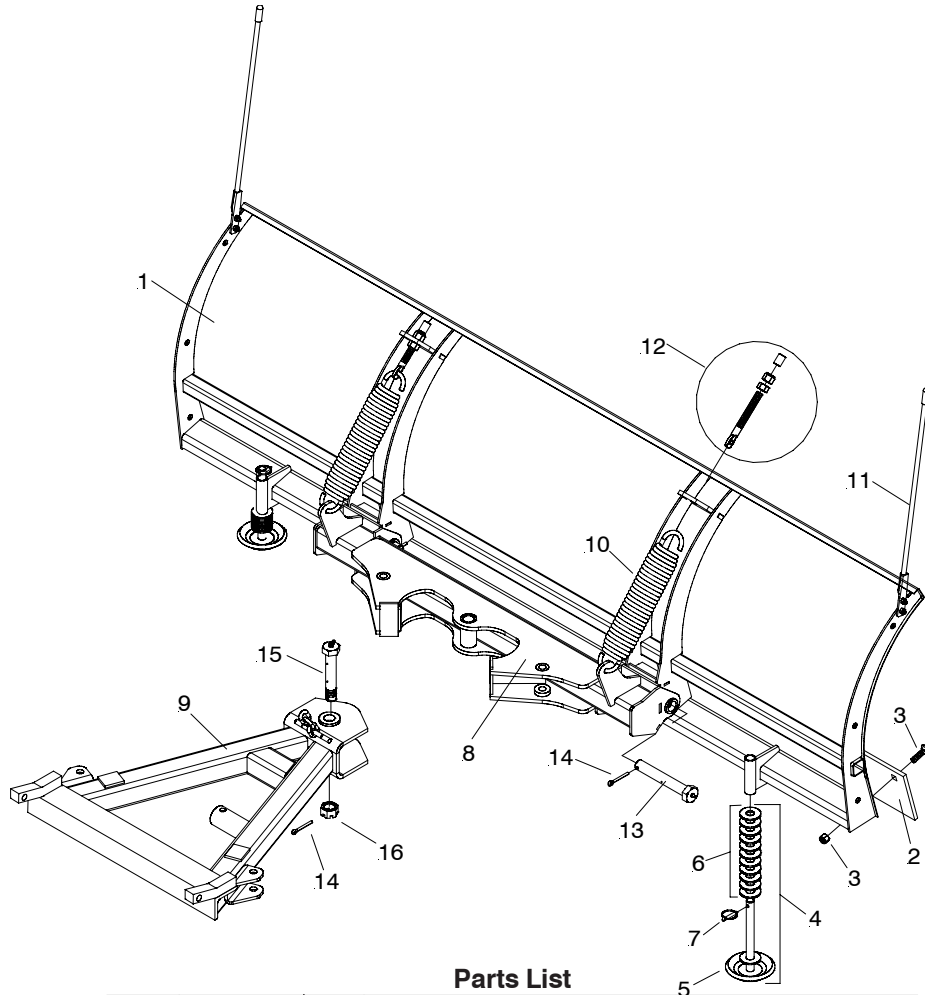

Parts List

Item	LP - 7.5	Qty	Description
1	09275	1	Moldboard Assembly
2	09796	1	• Cutting Edge 3/8" x 7'-6"
3	08184	1	• Bolt C 1/2-13 x 1-3/4 & Locknut (Kit of 9 each)
4	09127	2	• Mushroom Shoe Casting Assy.
5	10853	1	• Runner Shoe Casting
6	20359	12	• Flatwasher 3/4
7	22083	1	• Linch Pin
	13512	2	• Stops
	16548	1	Pivot Bar & A-Frame Carton
8	12590	1	• Pivot Bar DP Series
9	13520	1	• A-Frame (3-1/2" x 29" x 23-1/2")
10	07178	2	• Trip Spring
11	09917	1	• Plow Marker Kit
	08154	1	• Hardware Bag
12	09124	2	• Eye Bolt w/ Locknut & Cap
13	22333	2	• Pivot Pin 1 x 6-5/8" w/grease fitting
14	20406	3	• Cotter Pin 3/16 x 1-1/2"
15	22398	1	• King Pivot Bolt 1-8 x 5-1/2" w/grease fitting
16	22274	1	• Hex Nut Slotted 1-8

Parts indented are included in the assembly under which they are indented.

INSTALLATION INSTRUCTIONS

Note: The following instructions cover assembly of Moldboard, Pivot Bar and A-Frame. Refer to separate instructions for installation of plow mounting and hydraulic system.

- A. Liberally coat Pivot Pins (13) with chassis lubricant.
- B. Attach Pivot Bar (8) to Moldboard (1) with Pivot Pins (13) (grease fitting facing outward) and insert Cotter Pins (14). Grease outer Pivot Pin's (14) using grease fitting.
- C. Attach Eye Bolts (12) to Moldboard (1) and Trip Springs (10) to Pivot Bar (8), making certain locknuts are positioned as shown in Figure 1.
- D. Make certain each Eye Bolt (12) is in a vertical position as shown in Figure 1 so that the Eye Bolt (12) and Trip Spring (10) hinge properly when moldboard trips.

Note: Proper tension is attained when Trip Spring (10) coils just begin to separate and then tightening top locknut four additional turns. Tighten bottom Locknut (20530) to secure Eyebolt in position. Install Eyebolt caps (07031) over exposed threads. See Figure 1.

- E. Attach A-Frame (9) to Pivot Bar (8) using King Pivot Bolt (15), Hex Nut Slotted (16) and Cotter Pin (14). **IMPORTANT:** Install King Pivot Bolt (15) from top so that grease fitting is easily accessible. Grease King Pivot Bolt (15) using grease fitting.

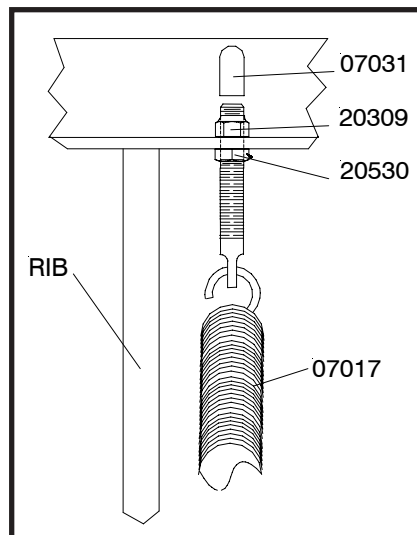

Figure 1

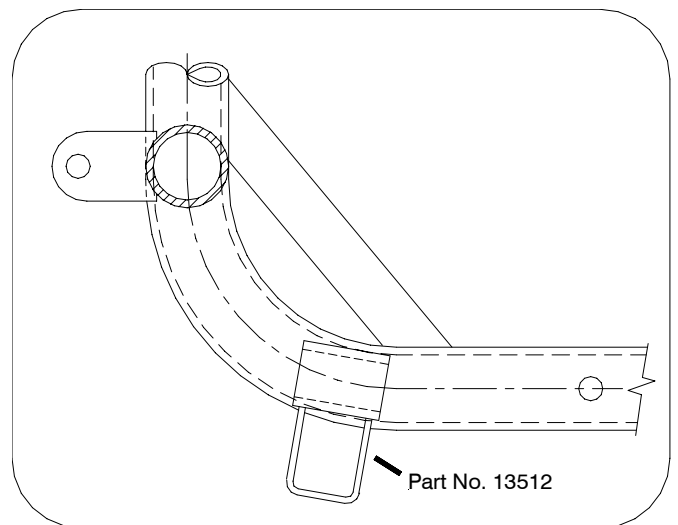

Figure 2

Note: 13512 Stops may need to be welded to the stops on the 11255 lift frame to avoid the plow lifting too high during stacking. See Figure 2.

Meyer Products LLC
18513 Euclid Ave. • Cleveland, Ohio 44112-1084
Phone 486-1313 (Area Code 216)
www.meyerproducts.com • email info@meyerproducts.com

Meyer Products LLC
6 Angell Lane • Damariscotta, ME 04543-4507
Phone 563-2227 (Area Code 207)
www.meyerproducts.com • email info@meyerproducts.com

