

Parts & Installation Instructions

EZ Mount Classic Model LP-7.5, LP-8, LP-8.5 & LP-9 Lot Pro™ Moldboards

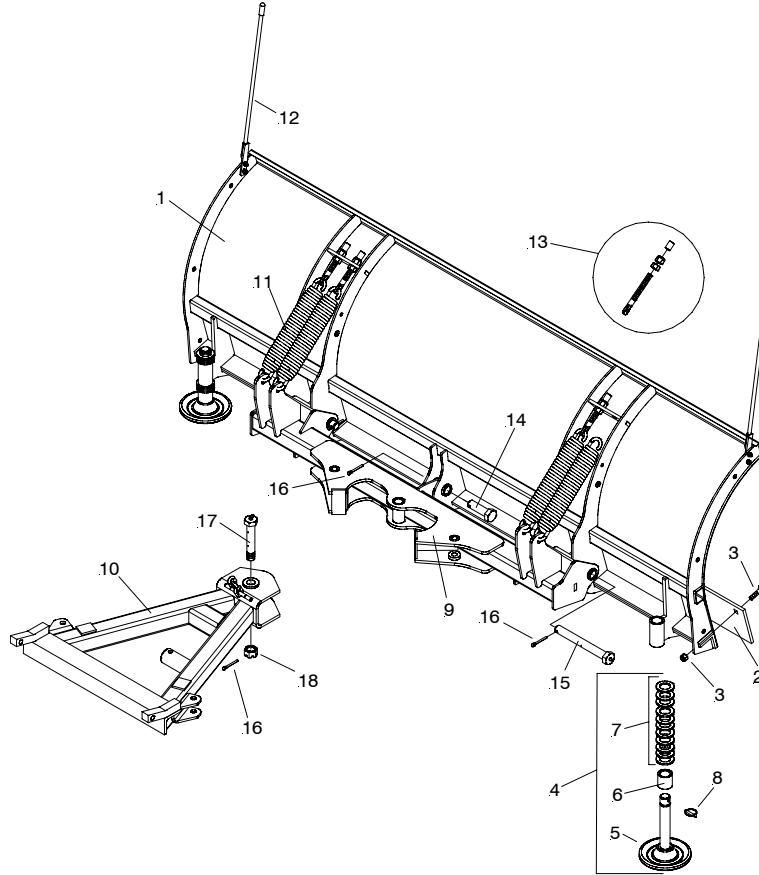

Parts List

Item	LP - 7.5	LP - 8.0	LP - 8.5	LP - 9.0	Qty	Description
1	09400	09401	09402	09403	1	Moldboard Assembly
2	09796	09133	09134	07259	1	• Cutting Edge
3	08486	-----	-----	-----	1	• Bolt C 1/2-13 x 1-3/4 & Locknut (Kit of 9 each)
3	-----	08692	08692	-----	1	• Bolt C 1/2-13 x 2 & Locknut (Kit of 10 each)
3	-----	-----	-----	08318	1	• Bolt C 5/8-11 x 2-1/4 & Locknut (Kit of 12 each)
4	09362	09362	09362	09362	2	• Mushroom Shoe Casting Assy.
5	12394	12394	12394	12394	1	•• Runner Shoe Casting
6	12449	12449	12449	12449	1	•• Runner Spacer
7	20363	20363	20363	20363	11	•• Flatwasher 1-1/4
8	22083	22083	22083	22083	1	•• Linch Pin
9	16549	16549	16549	16549	1	Pivot Bar & A-Frame Carton
9	12750	12750	12750	12750	1	• Pivot Bar LP Series
10	13520	13520	13520	13520	1	• A-Frame (3-1/2" x 29" x 23-1/2")
11	07017	07017	07017	07017	4	• Trip Spring
12	08852	08852	08852	08852	1	• Plow Marker Kit
13	08152	08152	08152	08152	1	• Hardware Bag
13	09124	09124	09124	09124	4	•• Eye Bolt w/ Locknut & Cap
14	22331	22331	22331	22331	1	•• Hex Head Pin 1 x 3-5/16"
15	22375	22375	22375	22375	2	•• Pivot Pin 1 x 8-3/4" w/grease fitting
16	20406	20406	20406	20406	4	•• Cotter Pin 3/16 x 1-1/2"
17	22398	22398	22398	22398	1	•• King Pivot Bolt 1-8 x 5-1/2" w/grease fitting
18	22274	22274	22274	22274	1	•• Hex Nut Slotted 1-8

Parts indented are included in the assembly under which they are indented.

INSTALLATION INSTRUCTIONS

Note: The following instructions cover assembly of Moldboard, Pivot Bar and A-Frame. Refer to separate instructions for installation of plow mounting and hydraulic system.

- A. Liberally coat Pivot Pins (14 & 15) with chassis lubricant.
- B. Attach Pivot Bar (9) to Moldboard (1) with Pivot Pins (14 & 15) (grease fitting facing outward) and insert Cotter Pins (16). Grease outer Pivot Pin's (15) using grease fitting.
- C. Attach Eye Bolts (13) to Moldboard (1) and Trip Springs (11) to Pivot Bar (9), making certain locknuts are positioned as shown in Figure 1.
- D. Make certain each Eye Bolt (13) is in a vertical position as shown in Figure 1 so that the Eye Bolt (13) and Trip Spring (11) hinge properly when moldboard trips.

Note: Proper tension is attained when Trip Spring (11) coils just begin to separate and then tightening top locknut four additional turns. Tighten bottom Locknut (20530) to secure Eyebolt in position. Install Eyebolt caps (07031) over exposed threads. See Figure 1.

- E. Attach A-Frame (10) to Pivot Bar (9) using King Pivot Bolt (17), Hex Nut Slotted (18) and Cotter Pin (16). **IMPORTANT:** Install King Pivot Bolt (17) from top so that grease fitting is easily accessible. Grease King Pivot Bolt (17) using grease fitting.

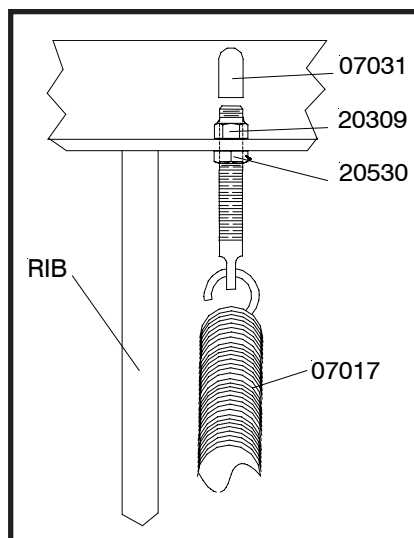

Figure 1

Meyer Products LLC
18513 Euclid Ave. • Cleveland, Ohio 44112-1084
Phone 486-1313 (Area Code 216)
www.meyerproducts.com • email info@meyerproducts.com



Meyer Products LLC
6 Angell Lane • Damariscotta, ME 04543-4507
Phone 563-2227 (Area Code 207)
www.meyerproducts.com • email info@meyerproducts.com