



## B30042-1

### UNDERCARRIAGE KIT

GM K1500 HD Silverado/Sierra	2001 - 03
GM K2500 Silverado/Sierra	1999 - ___
GM Suburban/Yukon XL 2500	2000 - ___
GM Avalanche 2500	2002 - ___
GM K3500 Silverado/Sierra	2001 - ___

#### Parts List and Installation Instructions

**⚠ CAUTION**

Read this document before installing the snowplow.

**⚠ CAUTION**

See your BLIZZARD® outlet/Web site for specific vehicle application recommendations before installation. The Undercarriage Selection Guide has specific vehicle and snowplow requirements.

# SAFETY

---

## SAFETY DEFINITIONS

### WARNING

Indicates a potentially hazardous situation that, if not avoided, could result in death or serious personal injury.

### CAUTION

Indicates a potentially hazardous situation that, if not avoided, may result in minor or moderate injury. It may also be used to alert against unsafe practices.

---

**NOTE:** Indicates a situation or action that can lead to damage to your snowplow and vehicle or other property. Other useful information can also be described.

---

# SAFETY

## SAFETY PRECAUTIONS

Improper installation and operation could cause personal injury, and/or equipment and property damage. Read and understand labels and the Owner's Manual before installing, operating or making adjustments.

### **⚠ WARNING**

**Lower blade when vehicle is parked. Temperature changes could change hydraulic pressure, causing the blade to drop unexpectedly or damaging hydraulic components. Failure to do this could result in serious personal injury.**

### **⚠ WARNING**

**The driver shall keep bystanders clear of the blade when it is being raised, lowered or angled. Do not stand between the vehicle and the blade or within 8 feet of a moving blade. A moving or falling blade could cause personal injury.**

### **⚠ WARNING**

**Keep hands and feet clear of the blade and A-frame when mounting or dismounting the snowplow. Moving or falling assemblies could cause personal injury.**

### **⚠ WARNING**

**Do not exceed GVWR or GAWR including the blade and ballast. The rating label is found on the driver-side vehicle door cornerpost.**

### **⚠ WARNING**

**To prevent accidental movement of the blade, always turn the ON/OFF switch to OFF whenever the snowplow is not in use. The control indicator light will turn off.**

### **⚠ WARNING**

**Remove blade assembly before placing vehicle on hoist.**

### **⚠ CAUTION**

**Refer to the Undercarriage Selection Guide for minimum vehicle recommendations and ballast requirements.**

## PERSONAL SAFETY

- Remove ignition key and put the vehicle in park or in gear to prevent others from starting the vehicle during installation or service.
- Wear only snug-fitting clothing while working on your vehicle or snowplow.
- Do not wear jewelry or a necktie, and secure long hair.
- Wear safety goggles to protect your eyes from battery acid, gasoline, dirt and dust.
- Avoid touching hot surfaces such as the engine, radiator, hoses and exhaust pipes.
- Always have a fire extinguisher rated BC handy, for flammable liquids and electrical fires.

## FIRE AND EXPLOSION

### **⚠ WARNING**

**Gasoline is highly flammable and gasoline vapor is explosive. Never smoke while working on vehicle. Keep all open flames away from gasoline tank and lines. Wipe up any spilled gasoline immediately.**

Be careful when using gasoline. Do not use gasoline to clean parts. Store only in approved containers away from sources of heat or flame.

## VENTILATION

### **⚠ WARNING**

**Vehicle exhaust contains lethal fumes. Breathing these fumes, even in low concentrations, can cause death. Never operate a vehicle in an enclosed area without venting exhaust to the outside.**

# TORQUE SPECIFICATIONS

## TORQUE CHART

### ⚠ CAUTION

Read instructions before assembling. Fasteners should be finger tight until instructed to tighten according to the torque chart. Use standard methods and practices when attaching snowplow including proper personal protective safety equipment.



Grade Identification for J429–Grade 5 Bolt



Grade Identification for J429–Grade 8 Bolt

SAE J429 Grade 5 Torque Values				SAE J429 Grade 8 Torque Values			
Nominal Thread Size	Clamp Loads (lbs)	Tightening Torque		Nominal Thread Size	Clamp Loads (lbs)	Tightening Torque	
		"Lubricated"	"Dry"			"Lubricated"	"Dry"
1/4-20	2,000	6 ft-lbs	8 ft-lbs	1/4-20	2,850	9 ft-lbs	12 ft-lbs
5/16-18	3,350	13 ft-lbs	18 ft-lbs	5/16-18	4,700	18 ft-lbs	25 ft-lbs
3/8-16	4,950	23 ft-lbs	31 ft-lbs	3/8-16	6,950	32 ft-lbs	44 ft-lbs
7/16-14	6,800	37 ft-lbs	50 ft-lbs	7/16-14	9,600	53 ft-lbs	70 ft-lbs
1/2-13	9,050	57 ft-lbs	75 ft-lbs	1/2-13	12,800	80 ft-lbs	107 ft-lbs
9/16-12	11,600	82 ft-lbs	109 ft-lbs	9/16-12	16,400	115 ft-lbs	154 ft-lbs
5/8-11	14,500	113 ft-lbs	151 ft-lbs	5/8-11	20,300	159 ft-lbs	211 ft-lbs
3/4-10	21,300	200 ft-lbs	266 ft-lbs	3/4-10	30,100	282 ft-lbs	376 ft-lbs
7/8-9	29,435	321 ft-lbs	430 ft-lbs	7/8-9	41,550	454 ft-lbs	606 ft-lbs
1-8	38,600	482 ft-lbs	640 ft-lbs	1-8	54,540	680 ft-lbs	900 ft-lbs



Grade Identification for Metric–Grade 8.8 Bolt



Grade Identification for Metric–Grade 10.9 Bolt

Metric Class 8.8 Torque Values				Metric Class 10.9 Torque Values			
Diameter (mm)	Clamp Loads (lbs)	Tightening Torque		Diameter (mm)	Clamp Loads (lbs)	Tightening Torque	
		"Lubricated"	"Dry"			"Lubricated"	"Dry"
5	1,389	3 ft-lbs	5 ft-lbs	5	1,987	5 ft-lbs	7 ft-lbs
6	1,965	6 ft-lbs	8 ft-lbs	6	2,812	8 ft-lbs	11 ft-lbs
7	2,826	10 ft-lbs	13 ft-lbs	7	4,044	14 ft-lbs	19 ft-lbs
8	3,579	14 ft-lbs	19 ft-lbs	8	5,121	20 ft-lbs	27 ft-lbs
10	5,672	28 ft-lbs	37 ft-lbs	10	8,116	40 ft-lbs	53 ft-lbs
12	8,243	49 ft-lbs	65 ft-lbs	12	11,796	70 ft-lbs	92 ft-lbs
14	11,246	77 ft-lbs	103 ft-lbs	14	16,092	111 ft-lbs	148 ft-lbs
16	15,882	125 ft-lbs	167 ft-lbs	16	21,970	173 ft-lbs	231 ft-lbs
18	19,423	172 ft-lbs	229 ft-lbs	18	26,868	238 ft-lbs	317 ft-lbs
20	24,784	244 ft-lbs	325 ft-lbs	20	34,284	338 ft-lbs	450 ft-lbs

# PUSHBEAM

---

## PUSHBEAM HEIGHT

The recommended pushbeam height for this undercarriage assembly is 12-1/2" from the center of the pushbeam to level ground. DO NOT exceed 14-1/2" in height for this undercarriage.

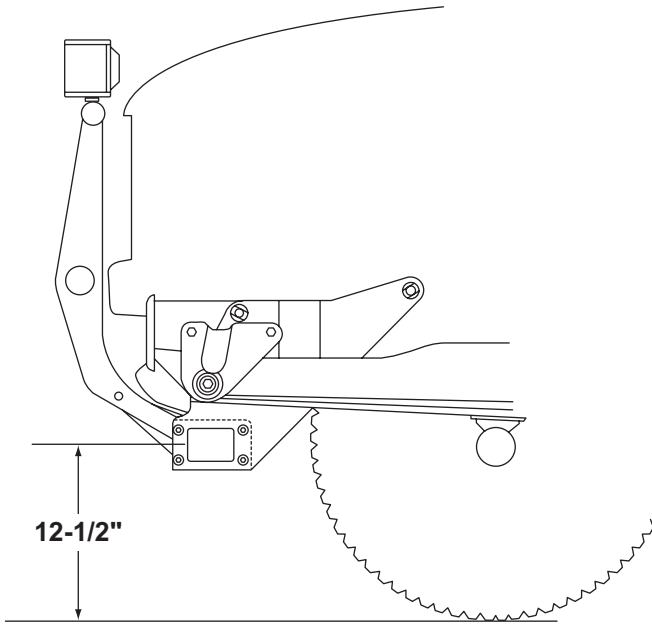

# UNDERCARRIAGE INSTALLATION

---

---

**NOTE: For easier assembly and installation, vehicle and all snowplow components should be on a smooth, level, hard surface, such as concrete.**

---

1. Remove the plastic bumper fascia mounted to the bottom of the front bumper. For the Avalanche, remove the entire plastic bumper. Disconnect the fog lamp electrical harnesses, if equipped, prior to removing the bumper. Remove tow hooks.

---

**NOTE: The airfoil/bumper will need to be permanently removed or notched to accommodate the undercarriage assembly.**

---

2. Align the undercarriage tabs (at each end of the pushbeam weldment) with the tow hook mounting holes on the vehicle.

---

**NOTE: Use a floor jack to help facilitate the installation procedure.**

---

3. Insert two 1/2" x 1-3/4" cap screws with 1/2" washers into the front of the truck frame and out through the tow hook mounting holes and undercarriage tabs at each end of the assembly. Attach 1/2" locknuts and finger tighten the fasteners until all undercarriage parts are in place.

4. Insert a 1/2" x 1-1/2" cap screw with handle and 1/2" washer in through the truck frame and out through the rear tow hook mount at each side of the pushbeam. Attach the large 1/2" washer, then the hardened 1/2" washer and locknut and finger tighten.
5. With the rear section of the pushbeam in place, insert a 5/8" x 2" cap screw and 5/8" washer down through frame cross member and fasten loosely with a 5/8" washer and locknut.
6. Tighten all fasteners according to torque chart.

---

**NOTE: After five to ten hours of snowplow usage, retorque all undercarriage assembly fasteners.**

---

# UNDERCARRIAGE PARTS LIST

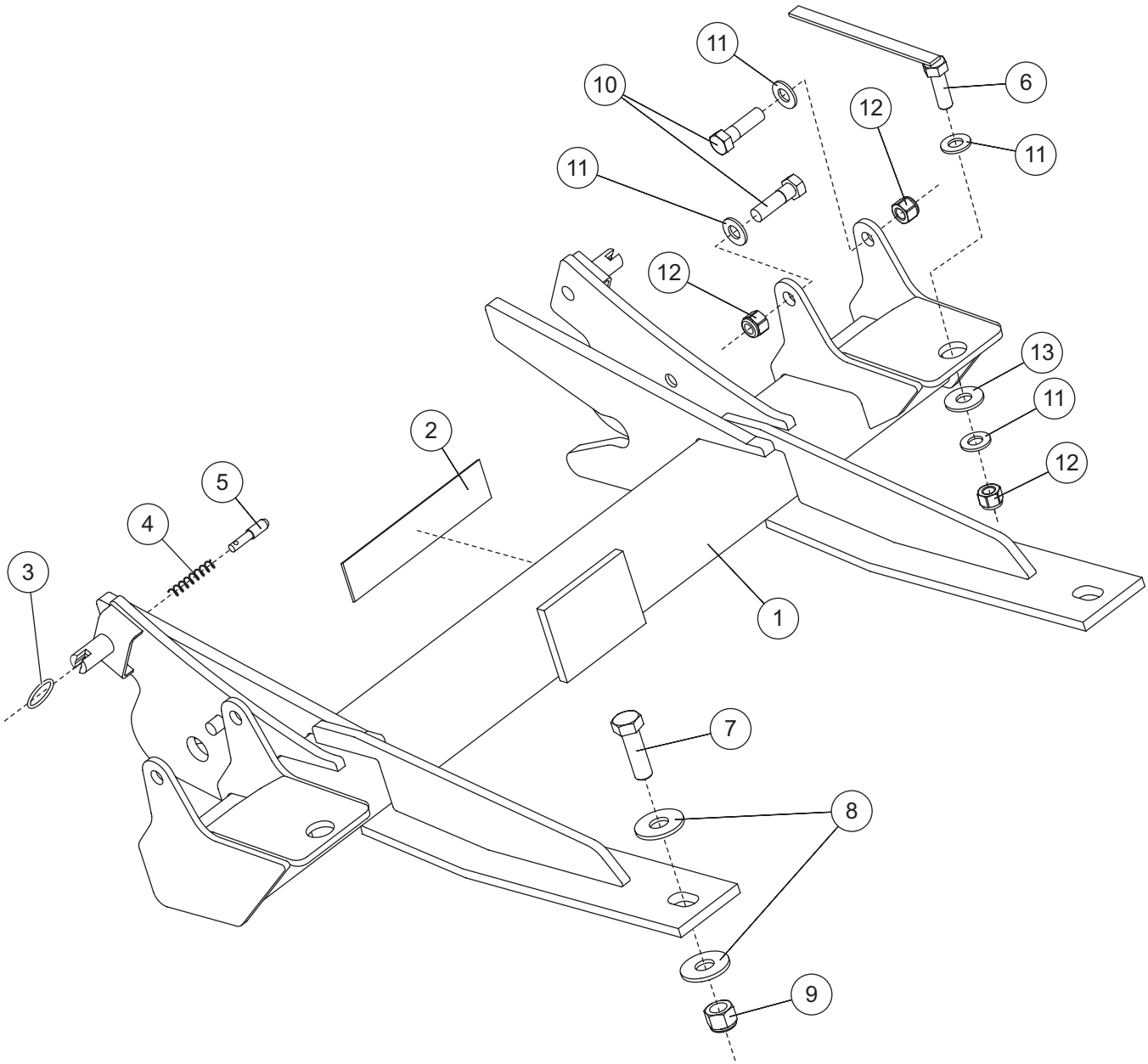

<b>B30042-1 Undercarriage Kit</b>							
Item	Part	Qty	Description	Item	Part	Qty	Description
1		1	Pushbeam	5	B40079	2	A-Frame Latch Pin
2	B63162	1	Label, Pushbeam	6	21590	2	1/2-13 x 1-1/2 Hex Cap Screw G5 with Handle
3	B61309	2	Split Ring, 1.25 OD	ns	29892	1	Hardware Kit
4	B61000	2	Compression Spring SS	<b>29892 Hardware Kit</b>			
7	90129	2	5/8-11 x 2 Hex Cap Screw G5	11	90572	14	1/2 Hardened Flat Washer
8	90576	4	5/8 Hardened Flat Washer	12	91335	6	1/2-13 Hex Locknut GB
9	91337	2	5/8-11 Hex Locknut GB	13	91105	2	1/2 Flat Washer
10	90101	4	1/2-13 x 1-3/4 Hex Cap Screw G5				
			ns = not shown			SS = Stainless Steel	
						G = Grade	



Blizzard  
P.O. Box 245038  
Milwaukee, WI 53224-9538  
[www.blizzardplows.com](http://www.blizzardplows.com)

 A DIVISION OF DOUGLAS DYNAMICS, L.L.C.

Copyright © 2007 Douglas Dynamics, L.L.C. All rights reserved. This material may not be reproduced or copied, in whole or in part, in any printed, mechanical, electronic, film or other distribution and storage media, without the written consent of Blizzard. Authorization to photocopy items for internal or personal use by Blizzard outlets or snowplow owner is granted.

Blizzard reserves the right under its product improvement policy to change construction or design details and furnish equipment when so altered without reference to illustrations or specifications used. Blizzard or the vehicle manufacturer may require or recommend optional equipment for snow removal. Do not exceed vehicle ratings with a snowplow. Blizzard offers a limited warranty for all snowplows and accessories. See separately printed page for this important information. The following is a registered (®) trademark of Douglas Dynamics, L.L.C.: BLIZZARD®.

**Printed in U.S.A.**