



B35018

UNDERCARRIAGE KIT

Toyota Tacoma

1995-1/2 - 04

Parts List & Installation Instructions

⚠ CAUTION

Read this document before installing the snowplow.

⚠ CAUTION

See your BLIZZARD® outlet/Web site for specific vehicle application recommendations before installation. The Undercarriage Selection Guide has specific vehicle and snowplow requirements.

SAFETY

SAFETY DEFINITIONS

⚠ WARNING

Indicates a potentially hazardous situation that, if not avoided, could result in death or serious personal injury.

⚠ CAUTION

Indicates a potentially hazardous situation that, if not avoided, may result in minor or moderate injury. It may also be used to alert against unsafe practices.

NOTE: Indicates a situation or action that can lead to damage to your snowplow and vehicle or other property. Other useful information can also be described.

WARNING/CAUTION & INSTRUCTION LABELS

Become familiar with and inform users about the warning and instruction labels on the back of the blade.

NOTE: If labels are missing or cannot be read, see your sales outlet.



POWER PLOW® & SPEEDWING™ Blades Only (both sides)

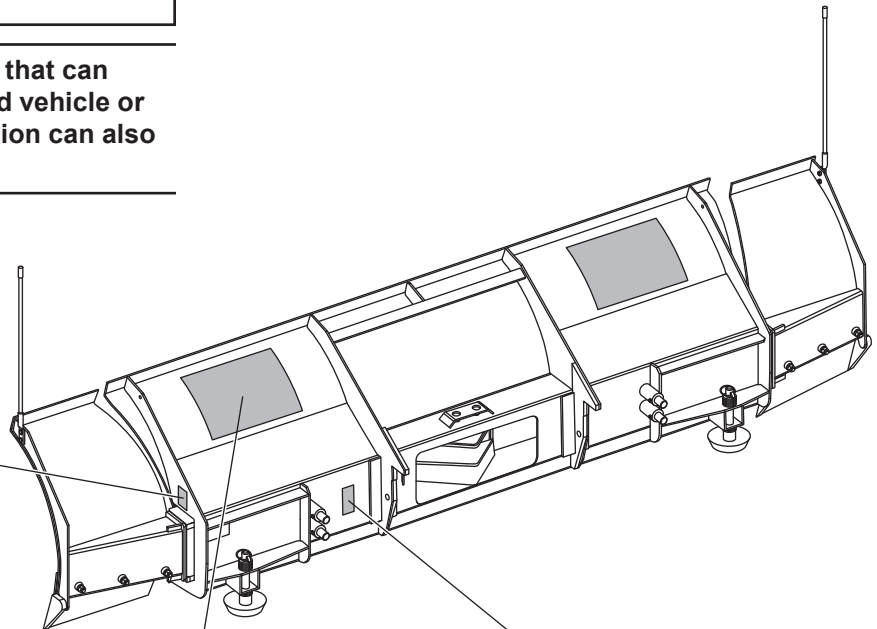

ATTACH	⚠ WARNING Keep fingers away from snowplow and truck attachment points. POWER HITCH™ 2 arm raises behind undercarriage pushbeam.	DETACH
<ol style="list-style-type: none"> Slowly drive vehicle forward to engage mount adapter into A-frame. Move power switch to center or "OFF" position. Plug in electrical harnesses. Push and hold power switch RIGHT and push UP and hold armblade operation switch. Arm will engage mount adapter and pull snowplow toward vehicle. Rotate and release hitch pin. Hitch pin is fully engaged when pin handle is against the pin guide plate. Repeat Step 5 on passenger's side. Rotate and release hitch pin. Hitch pin is fully engaged when pin handle is against the pin guide plate. While holding power switch RIGHT, push DOWN and hold armblade operation switch. Arm will disengage mount adapter to relieve tension on the stand. Pull stand handle up. Stand will lift off ground. Pull stand pin out. Rotate stand up until stand pin seats into upper hole. Pin must lock into upper A-frame hole. Repeat Step 8 on passenger's side. Pull stand handle up. Stand will lift off ground. Pull stand pin out. Rotate stand up until stand pin seats into upper hole. Pin must lock into upper A-frame hole. Move power switch to left or "Plowing" position. 		<ol style="list-style-type: none"> Lower snowplow into ground with blade straight. Turn snowplow control in cab OFF. Move power switch to center or "OFF" position. While holding the power switch RIGHT, push DOWN and hold the armblade operation switch. Arm will disengage mount adapter to relieve tension on the stand. Pull stand pin out. Rotate stand down until stand pin seats into lower A-frame hole. Push down on top of shoe. Shoe will be on the ground. Repeat Step 4 on passenger's side. Pull stand pin out. Rotate stand down until stand pin seats into lower A-frame hole. Push down on top of shoe. Shoe will be on the ground. Push and hold power switch RIGHT and push UP the armblade operation switch. Arm will engage mount adapter and pull snowplow tightly to vehicle. Rotate and pull hitch pin. Rotate hitch pin into retracted position. Repeat Step 7 on passenger's side. Rotate and pull hitch pin. Rotate hitch pin into retracted position. While holding power switch RIGHT, push DOWN and hold armblade operation switch to fully lower arm. Unplug electrical harnesses.
<p>POWER HITCH 2</p> <p>Read Owner's Manual for complete instructions.</p> <p>U.S. patents 5,420,480; 5,638,618; 5,899,007; 6,178,089; 6,253,470; 6,276,076; 6,393,737; 6,408,548; 6,410,199; 6,442,877; 6,615,513; 7,134,227; 7,400,058; 7,439,821; RESS 700; CAN patents 2,000,425; 2,184,922; 2,220,783; 2,258,508; 2,359,145; 2,358,354; 2,359,533; and other patents pending.</p> <p>BLIZZARD</p>		

SAFETY

SAFETY PRECAUTIONS

Improper installation and operation could cause personal injury and/or equipment and property damage. Read and understand labels and the Owner's Manual before installing, operating or making adjustments.

⚠ WARNING

Lower the blade when vehicle is parked. Temperature changes could change hydraulic pressure, causing the blade to drop unexpectedly or damaging hydraulic components. Failure to do this could result in serious personal injury.

⚠ WARNING

The driver shall keep bystanders clear of the blade when it is being raised, lowered or angled. Do not stand between the vehicle and the blade or within 8 feet of a moving blade. A moving or falling blade could cause personal injury.

⚠ WARNING

Keep hands and feet clear of the blade and A-frame when mounting or removing the snowplow. Moving or falling assemblies could cause personal injury.

⚠ WARNING

Do not exceed GVWR or GAWR including the blade and ballast. The rating label is found on the driver-side vehicle door cornerpost.

⚠ WARNING

To prevent accidental movement of the blade, always turn the control OFF whenever the snowplow is not in use. The power indicator light will turn OFF.

⚠ WARNING

Remove blade assembly before placing vehicle on hoist.

⚠ CAUTION

Refer to the Undercarriage Selection Guide for minimum vehicle recommendations and ballast requirements.

PERSONAL SAFETY

- Remove ignition key and put the vehicle in park or in gear to prevent others from starting the vehicle during installation or service.
- Wear only snug-fitting clothing while working on your vehicle or snowplow.
- Do not wear jewelry or a necktie, and secure long hair.
- Wear safety goggles to protect your eyes from battery acid, gasoline, dirt and dust.
- Avoid touching hot surfaces such as the engine, radiator, hoses and exhaust pipes.
- Always have a fire extinguisher rated BC handy, for flammable liquids and electrical fires.

FIRE AND EXPLOSION

⚠ WARNING

Gasoline is highly flammable, and gasoline vapor is explosive. Never smoke while working on vehicle. Keep all open flames away from gasoline tank and lines. Wipe up any spilled gasoline immediately.

Be careful when using gasoline. Do not use gasoline to clean parts. Store only in approved containers away from sources of heat or flame.

CELL PHONES

A driver's first responsibility is the safe operation of the vehicle. The most important thing you can do to prevent a crash is to avoid distractions and pay attention to the road. Wait until it is safe to operate Mobile Communication Equipment such as cell phones or two-way radios.

VENTILATION

⚠ WARNING

Vehicle exhaust contains lethal fumes. Breathing these fumes, even in low concentrations, can cause death. Never operate a vehicle in an enclosed area without venting exhaust to the outside.

TORQUE SPECIFICATIONS

TORQUE CHART

⚠ CAUTION

Read instructions before assembling. Fasteners should be finger tight until instructed to tighten according to the torque chart. Use standard methods and practices when attaching snowplow including proper personal protective safety equipment.



Grade Identification for J429–Grade 5 Bolt



Grade Identification for J429–Grade 8 Bolt

SAE J429 Grade 5 Torque Values				SAE J429 Grade 8 Torque Values			
Nominal Thread Size	Clamp Loads (lb)	Tightening Torque		Nominal Thread Size	Clamp Loads (lb)	Tightening Torque	
		"Lubricated"	"Dry"			"Lubricated"	"Dry"
1/4-20	2,000	6 ft-lb	8 ft-lb	1/4-20	2,850	9 ft-lb	12 ft-lb
5/16-18	3,350	13 ft-lb	18 ft-lb	5/16-18	4,700	18 ft-lb	25 ft-lb
3/8-16	4,950	23 ft-lb	31 ft-lb	3/8-16	6,950	32 ft-lb	44 ft-lb
7/16-14	6,800	37 ft-lb	50 ft-lb	7/16-14	9,600	53 ft-lb	70 ft-lb
1/2-13	9,050	57 ft-lb	75 ft-lb	1/2-13	12,800	80 ft-lb	107 ft-lb
9/16-12	11,600	82 ft-lb	109 ft-lb	9/16-12	16,400	115 ft-lb	154 ft-lb
5/8-11	14,500	113 ft-lb	151 ft-lb	5/8-11	20,300	159 ft-lb	211 ft-lb
3/4-10	21,300	200 ft-lb	266 ft-lb	3/4-10	30,100	282 ft-lb	376 ft-lb
7/8-9	29,435	321 ft-lb	430 ft-lb	7/8-9	41,550	454 ft-lb	606 ft-lb
1-8	38,600	482 ft-lb	640 ft-lb	1-8	54,540	680 ft-lb	900 ft-lb



Grade Identification for Metric–Grade 8.8 Bolt



Grade Identification for Metric–Grade 10.9 Bolt

Metric Class 8.8 Torque Values				Metric Class 10.9 Torque Values			
Diameter (mm)	Clamp Loads (lb)	Tightening Torque		Diameter (mm)	Clamp Loads (lb)	Tightening Torque	
		"Lubricated"	"Dry"			"Lubricated"	"Dry"
5	1,389	3 ft-lb	5 ft-lb	5	1,987	5 ft-lb	7 ft-lb
6	1,965	6 ft-lb	8 ft-lb	6	2,812	8 ft-lb	11 ft-lb
7	2,826	10 ft-lb	13 ft-lb	7	4,044	14 ft-lb	19 ft-lb
8	3,579	14 ft-lb	19 ft-lb	8	5,121	20 ft-lb	27 ft-lb
10	5,672	28 ft-lb	37 ft-lb	10	8,116	40 ft-lb	53 ft-lb
12	8,243	49 ft-lb	65 ft-lb	12	11,796	70 ft-lb	92 ft-lb
14	11,246	77 ft-lb	103 ft-lb	14	16,092	111 ft-lb	148 ft-lb
16	15,882	125 ft-lb	167 ft-lb	16	21,970	173 ft-lb	231 ft-lb
18	19,423	172 ft-lb	229 ft-lb	18	26,868	238 ft-lb	317 ft-lb
20	24,784	244 ft-lb	325 ft-lb	20	34,284	338 ft-lb	450 ft-lb

PUSHBEAM

PUSHBEAM HEIGHT

The recommended pushbeam height for this undercarriage assembly is 10-1/2" from the center of the pushbeam to level ground. DO NOT exceed 12-1/2" in height for this undercarriage.

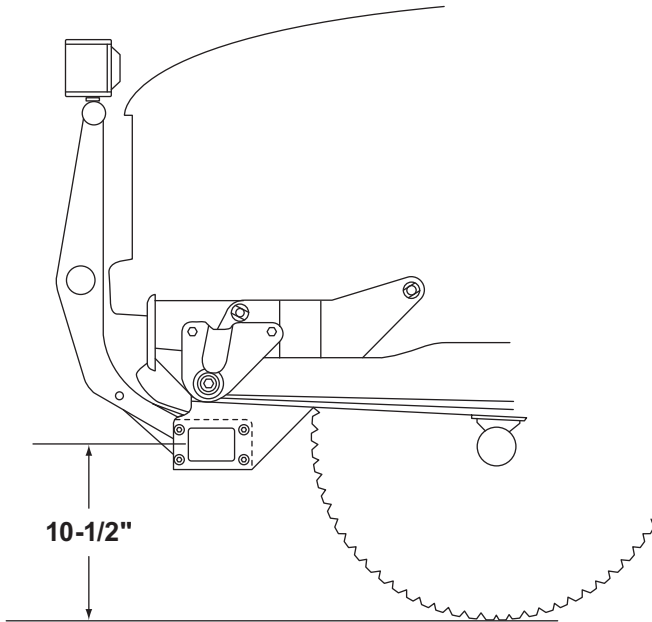

UNDERCARRIAGE INSTALLATION

NOTE: For easier assembly and installation, the vehicle and all snowplow components should be on a smooth, level, hard surface, such as concrete.

1. Remove and set aside the plastic pop rivets that secure the bumper fascia to the truck frame rail. Remove the bumper fascia.
2. Remove the hardware from the tow hooks at the end of each truck frame rail. Discard the fasteners.
3. Position the driver- and passenger-side hanger plates under the truck frame rails and align the center plate holes with the holes in the frame and tow hooks. Secure the plates to the tow hooks through the frame with M12 x 35mm cap screws and 7/16" washers. Finger tighten the fasteners until all undercarriage parts are in place.
4. Position the frame clamping plates with the 1/2" x 5" carriage bolts over the frame rails. Align the carriage bolts with the front and rear holes in the hanger plates and secure with 1/2" washers and 1/2" locknuts.
5. Mount the pushbeam square with the bottom of each hanger plate using 1/2" x 1-1/4" cap screws, 1/2" washers and 1/2" locknuts. Torque the pushbeam hardware according to the torque chart.
6. Align the cross member support with the vehicle cross member. Secure each side with 7/16" x 4" cap screws, 7/16" washers and 7/16" locknuts.
7. Level the pushbeam with the floor and tighten all hardware according to the torque chart.
8. Reinstall the bumper fascia to the truck frame rail with the plastic pop rivets.

NOTE: After five to ten hours of snowplow usage, retorque all undercarriage assembly fasteners.

UNDERCARRIAGE PARTS LIST

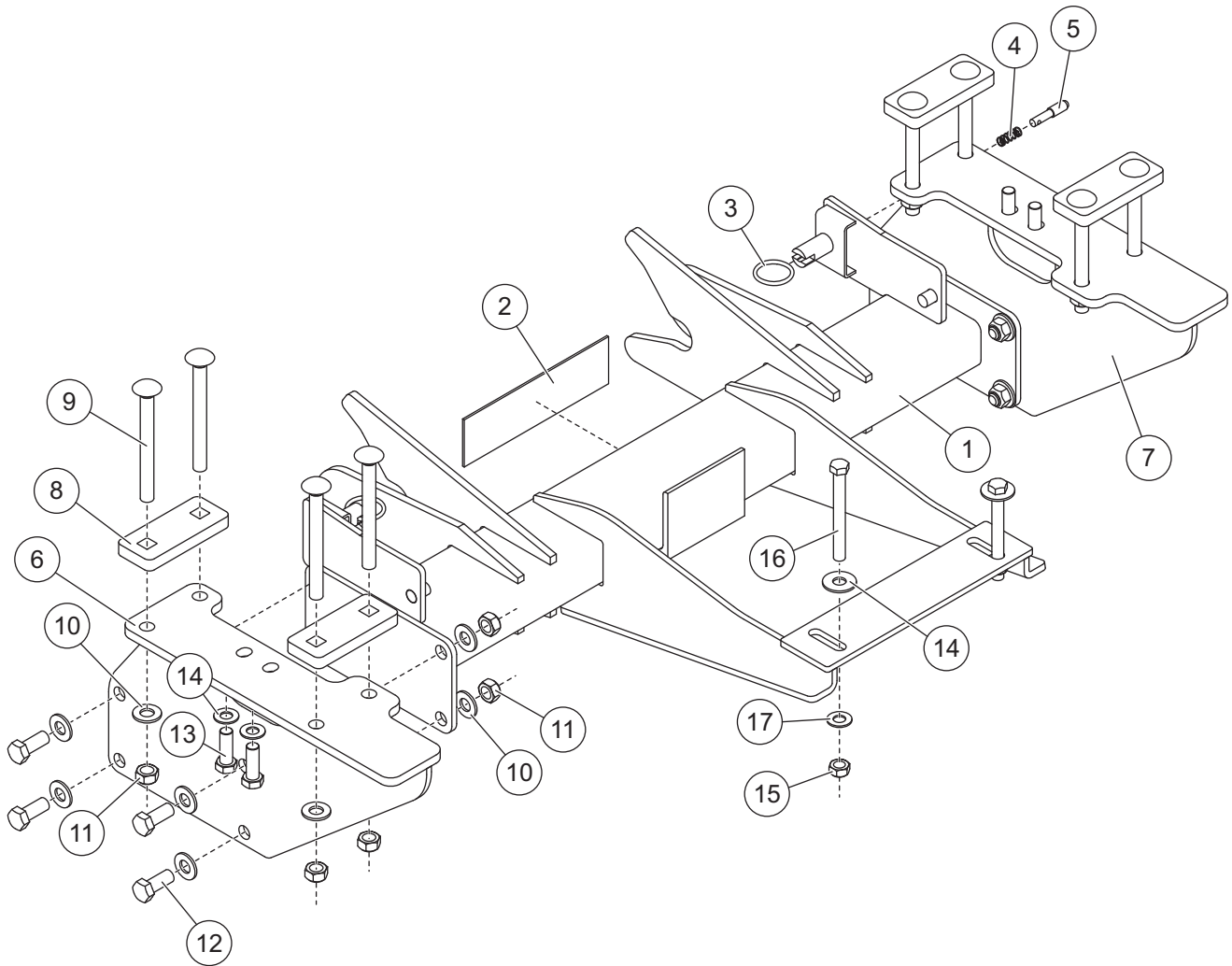

B35018 Undercarriage Kit							
Item	Part	Qty	Description	Item	Part	Qty	Description
1	B35016	1	Pushbeam	6	B35024	1	Hanger Plate – DS
2	B63162	1	Decal, Pushbeam	7	B35021	1	Hanger Plate – PS
3	B61309	2	Split Ring, 1.25 OD	8	B35022	4	Frame Clamping Plate
4	B61000	2	Compression Spring SS	ns	B61468	1	Hardware Kit
5	B40079	2	A-Frame Latch Pin				
B61468 Hardware Kit							
9	90253	8	1/2-13 x 5 Carriage Bolt G5	14	29232	6	7/16 Hardened Flat Washer
10	90572	24	1/2 Hardened Flat Washer	15	90353	2	7/16-14 Hex Locknut GB
11	90593	16	1/2-13 Hex Locknut GC	16	B61466	2	7/16-14 x 4 Hex Cap Screw G8
12	90665	8	1/2-13 x 1-1/4 Hex Cap Screw G8	17	91104	2	7/16 Flat Washer
13	B61467	4	M12-1.25 x 35 Hex Cap Screw G8.8				
ns = not shown			SS = Stainless Steel			G = Grade	

Copyright © 2011 Douglas Dynamics, L.L.C. All rights reserved. This material may not be reproduced or copied, in whole or in part, in any printed, mechanical, electronic, film or other distribution and storage media, without the written consent of Blizzard. Authorization to photocopy items for internal or personal use by Blizzard outlets or snowplow owner is granted.

Blizzard reserves the right under its product improvement policy to change construction or design details and furnish equipment when so altered without reference to illustrations or specifications used. Blizzard or the vehicle manufacturer may require or recommend optional equipment for snow removal. Do not exceed vehicle ratings with a snowplow. Blizzard offers a limited warranty for all snowplows and accessories. See separately printed page for this important information. The following are registered (®) or unregistered (™) trademarks of Douglas Dynamics, L.L.C.: BLIZZARD®, POWER HITCH™ 2, POWER PLOW®, SPEEDWING™.

Printed in U.S.A.