

LED Snow Plow Headlight Kit

IS276
Dec. 2018

Parts List

ITEM	PART NO.	QTY.	DESCRIPTION
1	LI81092R	1	Headlight Passenger Side
2	LI81092L	1	Headlight Driver Side
3	81-W540	1	Hardware Bag
4	BL38	4	•• Bolt, Hex Head
5	NT38	4	•• Nut
6	WS45	4	•• Lockwasher
7	BR81	2	•• Bracket, Bottom Mount
8	NT07	2	•• Nut
9	WS05	2	•• Lockwasher
10	WS19	4	•• Washer, Flat
11	GR18	2	•• Washer, Rubber
12	BL31	2	•• Bolt, Hex Head

ITEM	PART NO.	QTY.	DESCRIPTION
13	LI71080L	1	LED Module Driver Side without Heat Grid Activated High Beam: 1.0A @ 12Vdc Low Beam: 1.3A @ 12Vdc with Heat Grid Activated High Beam: 2.2A @ 12Vdc Low Beam: 2.5A @ 12Vdc
14	LI71080R (not shown)	1	LED Module Passenger Side without Heat Grid Activated High Beam: 1.0A @ 12Vdc Low Beam: 1.3A @ 12Vdc with Heat Grid Activated High Beam: 2.2A @ 12Vdc Low Beam: 2.5A @ 12Vdc
15	10-1157NA	2	1157NA Bulb Park/Turn 21W (installed in light)

Parts indented are included in carton, bag or assembly under which they are indented.

Part #81092

The LED lighting system includes two complete headlights with park and turn functions. The kits include mounting hardware and an integral 36" wire harness with no terminals or connectors attached. The installer is responsible for providing adequate connectors, wire, switches and fuses so the lighting system will operate within Federal, State and Provincial laws.

It is the responsibility of the installer and operator to ensure that the headlight system is mounted in accordance with all Federal, State and Provincial laws that may be applicable. The installer must ensure that the headlights are aimed in accordance with FMVSS and CMVSS 108 standards. Hamsar accepts no responsibility for the installation of the light system mentioned above.

Installation Instructions | Headlight Assembly

Please see the drawing below for mounting the LED headlight units. Tighten the nut assembly until it is firm. Do not overtighten. It is recommended that you check the tightness of the headlight assembly on a regular basis, weekly or monthly and retighten as required. Note: The park turn light must be on the "outside" of the assembly.

Wiring Instructions | Headlight Assembly

Hamsar provides wires exiting the headlight but no connectors or terminals are provided. The installer is responsible for finishing the connection to the vehicle. Please see below for the wire colours for the various functions. Note: It is very important to make proper connections and grounding. Ensure no grease, paint or dirt interferes with the ground connection. Note: Fuse the power connections with a maximum 10A fuse (not supplied).

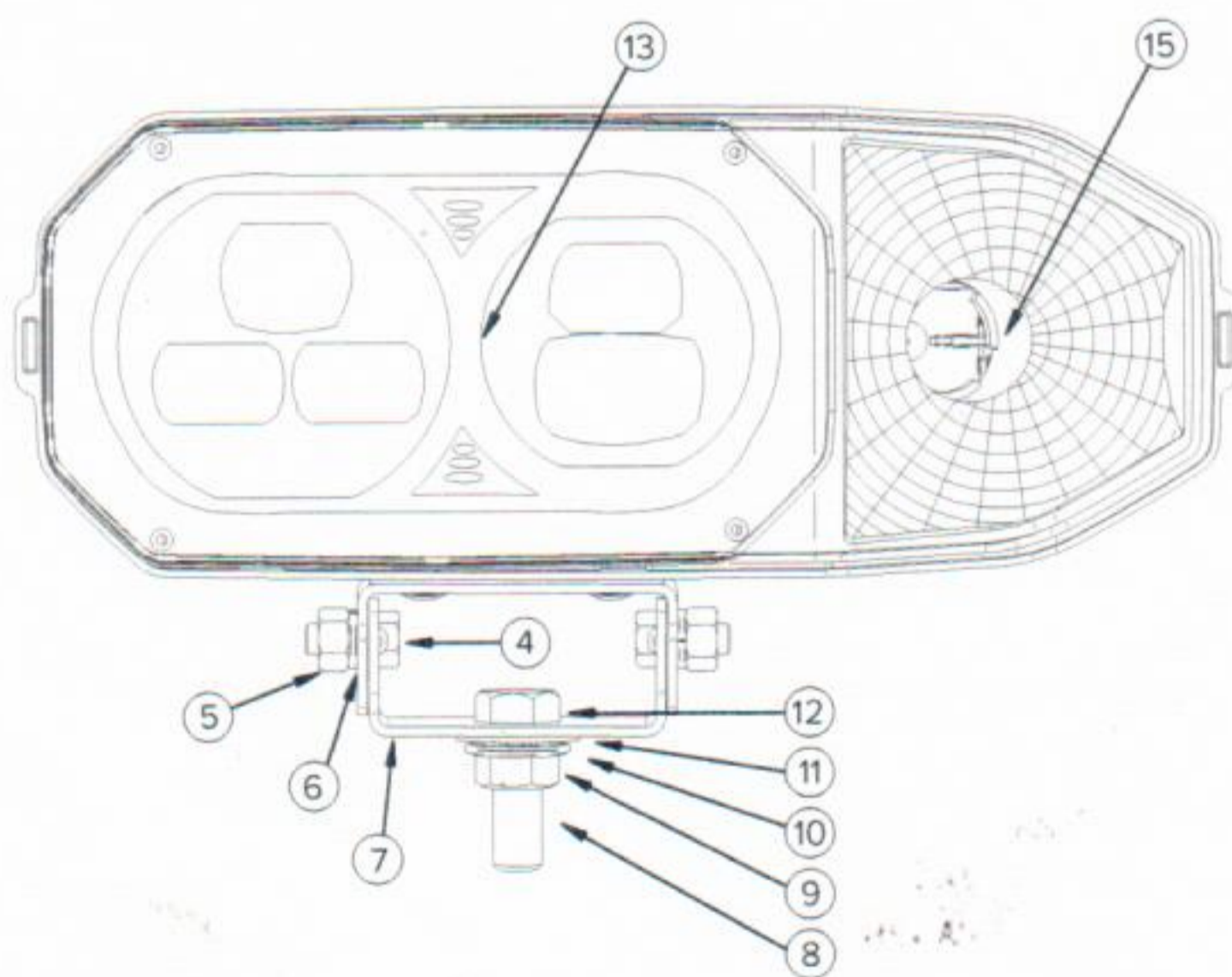

WIRE HARNESS

WIRE INTERNAL WIRE COLOR (FUNCTION)

- A YELLOW (PARK LAMP)
- B BLACK (GROUND)
- C GREEN (TURN LAMP)
- D RED (HIGH BEAM)
- E BLUE (COMMON)
- F WHITE (LOW BEAM)

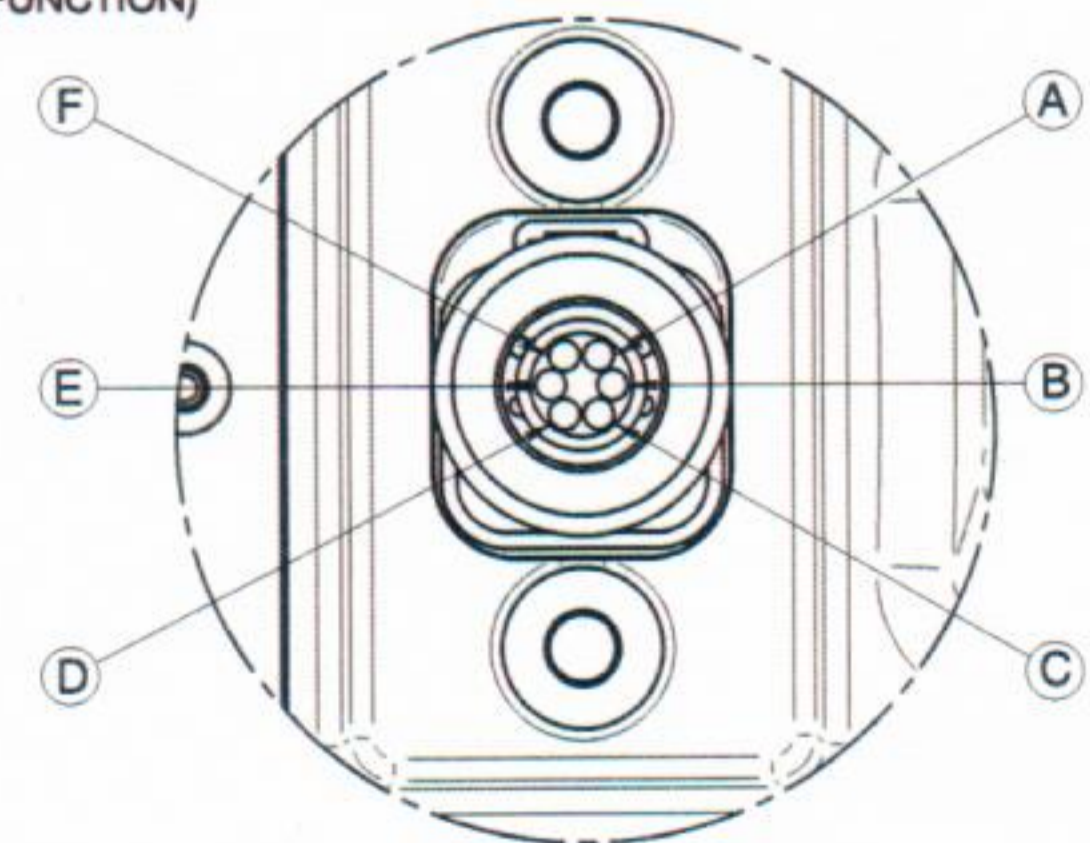

5320 Downey Street | Burlington | Ontario | Canada | L7L 6M2
Tel: 905.332.4094 | Fax: 905.332.9020 | Toll Free: 1.800.567.5483
sales@hamsar.com | www.hamsar.com
ISO9001:2015 | ISO14001:2015

Hamsar's Limited Product Warranty

The following warranty is exclusive and in lieu of all other warranties, whether expressed, implied or statutory with respect to or relating to any product shipped hereunder (the "Product"), including, but not limited to any warranty of merchantability or fitness for any particular purpose. Hamsar Diversco Inc. warrants that the Product is, at the time of shipment to the Purchaser, free of material and workmanship defects provided that there shall be no warranty with respect to any Product which has been repaired or altered in any way, which has been subject to negligence, accident, improper storage or damaged in shipment without the fault of Hamsar Diversco Inc. or has not been installed, used or maintained in accordance with normal practice and in conformity with the recommendations or the published specifications of Hamsar Diversco Inc. Hamsar Diversco Inc. shall, at its option, repair or replace any defective Product or refund the purchase price of a Product provided a warranty claim is made within one (1) year of the date of shipment of the Product and this shall be the full extent of Hamsar Diversco Inc.'s liability for breach of warranty.