

# PARTS & INSTALLATION INSTRUCTIONS

## E-Z MOUNT PLUS™ HD

### UNIVERSAL HD CLEVIS AND HD LIFT FRAME

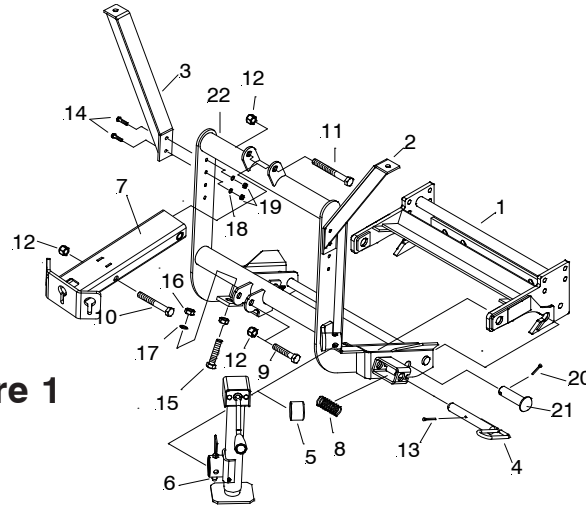

**Figure 1**

#### PARTS LIST

| Item | Part No.      | Qty. | Description                          |
|------|---------------|------|--------------------------------------|
|      | 16401         | 1    | <b>E-Z Mount Plus™ HD Assembly</b>   |
| 1    | 10564         | 1    | • E-Z Mount Plus™ HD Clevis Frame    |
| 2    | 11751         | 1    | •• L.H. Light Bracket                |
| 3    | 11752         | 1    | •• R.H. Light Bracket                |
| 4    | 11859         | 2    | •• Blue Handle Pin                   |
| 5    | 11844         | 1    | •• Receiver Tube Cap                 |
| 6    | 22245         | 1    | •• Crankstand                        |
| 7    | 13538         | 1    | •• Lift Arm                          |
|      | 08815         | 1    | •• <b>MOUNTING HARDWARE BAG</b>      |
| 8    | 814000005     | 2    | ••• Spring                           |
| 9    | 20146         | 1    | ••• Bolt H 5/8-11 x 3-1/4" Gr. 5     |
| 10   | 20152         | 1    | ••• Bolt H 5/8-11 x 5" Gr. 5         |
| 11   | 20153         | 1    | ••• Bolt H 5/8-11 x 5-1/2" Gr. 5     |
| 12   | 20309         | 3    | ••• Locknut Esna 5/8-11              |
| 13   | 20406         | 2    | ••• Cotter Pin 3/16 x 1-1/2"         |
| 14   | 20028         | 4    | ••• Bolt H 5/16-18 x 1-1/4" Gr. 2    |
| 15   | 8500003307001 | 2    | ••• Bolt H 5/8-11 x 3" Full Th'd Cap |
| 16   | 8501003013    | 4    | ••• Jam Nut 5/8-11                   |
| 17   | 20331         | 2    | ••• Lockwasher 5/8                   |
| 18   | 20326         | 4    | ••• Lockwasher 5/16                  |
| 19   | 20525         | 4    | ••• Hex Nut 5/16-18                  |
| 20   | 20420         | 2    | ••• Cotter Pin 1/4 x 2"              |
| 21   | 22436         | 2    | ••• 1"DIA X 3" Pin                   |
|      | 12536         | 1    | • Top Deflector                      |
|      | 14204         | 1    | • Bottom Belt                        |
|      | 08964         | 1    | • Hardware Bag (SV2 V-Plow)          |
|      | 13724         | 1    | •• Deflector Brace                   |
|      | 14205         | 2    | •• Backing Plate                     |
|      | 20028         | 7    | •• Bolt H 5/16-18 x 1-1/4" Gr. 2     |
|      | 20095         | 1    | •• Bolt H 1/2-13 x 1-1/2" Gr. 5      |
|      | 20304         | 7    | •• Locknut 5/16-18                   |
|      | 20309         | 2    | •• Locknut 5/8-11                    |
|      | 20329         | 1    | •• Lockwasher 1/2"                   |
|      | 20352         | 7    | •• Flatwasher 5/16"                  |
|      | 21962         | 2    | •• Bolt C 5/8-11 x 2-3/4"            |
| 22   | 10561         | 1    | Lift Frame                           |

**Parts indented are included in the carton, bag or assembly under which they are indented.**

Meyer Products LLC reserves the right, under its continuing product improvement program, to change construction or design details, specifications and prices without notice or without incurring any obligation.

## GENERAL INFORMATION

**CAUTION:** Always disconnect battery before beginning installation.

**DO NOT BURN** holes or **WELD** vehicle frame. This may cause frame failure.

After first use, re-tighten all mounting bolt connections to specified torque. All mounting bolt connections to be checked periodically for tightness.

Locknuts are furnished **DO NOT** tighten bolts and nuts until installation is complete (unless otherwise specified), then be sure to tighten all attaching parts per specified torque chart.

**NOTE:** It is important that the Meyer harness, all wires from the Meyer light switch, and all other electrical wires be routed around hot or moving engine parts, and any sharp metal. Protection must be provided to guard against wire damage at these points. All excess or loose wires must be neatly secured using wire ties.

Check contents against the parts list to determine all are correct and included, and also to familiarize yourself with them.

**SAFETY PRECAUTIONS** should be used when **Hydraulic Unit is in OPERATION** and plow is in a **RAISED** position. **Lower plow to ground when vehicle is PARKED.**

**OVERHAUL** and **SERVICE INFORMATION** are covered on separate instructions.

Follow these instructions explicitly. Warranty does not apply to a Meyer product which has been negligently or improperly assembled or installed.

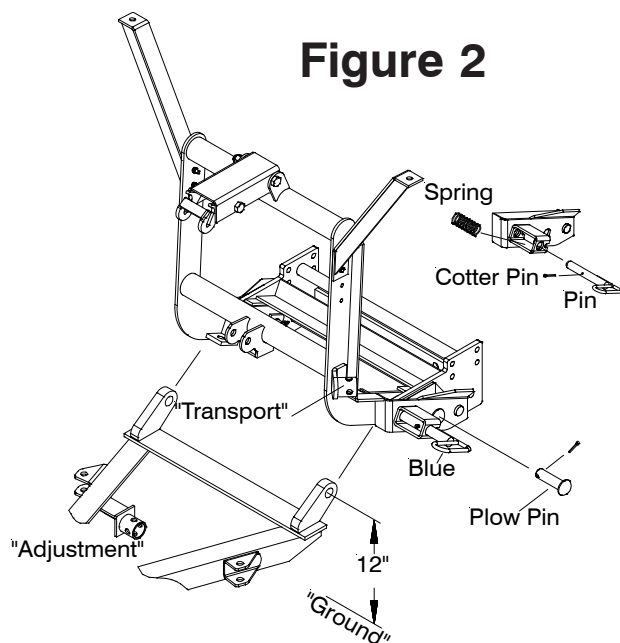

## INSTALLATION INSTRUCTIONS

- A. Assemble clevis frame (1) to vehicle per separate Mounting Carton Instructions.
- B. Assemble Blue Handle Pin (4) to lift frame (22) by inserting the Blue Handle Pin (4) through the outer lift frame plates, through the center of the spring (8). At this time align the small blue leg on the handle through the notch on the outermost plate. Compress the spring (8) slightly with your fingers and insert the 3/16" x 1-1/2" Cotter Pin (13) through the small hole towards the center of the pin. With cotter pin (13) fully inserted, pull the blue handle until the spring is fully compressed and rotate the handle one full turn to bend the cotter pin in place. Realign the small blue leg with the notch on the outermost plate to lock in place. Repeat assembly process (as per figure 2 & 3) until both pins are assembled. **Note: Lubricate the stainless steel pins and Lift Frame bearing surfaces with chassis grease or anti-seize lubricant periodically for easier disengagement of pins.**
- C. Attach lift frame (22) to clevis frame (1) (Ref. Figure 1) locate and pull out on the Blue Handled Pins and twist them slightly to the right or left so that the small leg of blue handle is resting on the outer plate, disengaging the pin. Align fixed pins (21) in Lift Frame (22) to notched hole on Clevis Frame (1) secure with Cotter Pin (20). Align Blue Handle Pins with the holes located on the clevis frame (1). Twist the Blue Handle Pins so that the small leg realigns with the slot, engaging the pin. The spring loaded pin should snap into place locking the lift frame to the clevis frame.
- D. Assemble adjustable stacking stop bolts to lift frame (22) using 5/8-11 x 3" bolts (15), lockwasher (17) and jamnuts (16) per figure 1. When using a Diamond Trip Edge moldboard both jamnuts are not required. See Figure 1. Adjustment bolts should be bottomed out on mounting plates. **Note:** Adjustment must be made after moldboard assembly is installed. Adjustment bolts (15) should make contact with the a-frame before any part of the A-Frame/ Sector or moldboard come in contact with the lift arm and, or hydraulic unit while raising the snowplow or stacking snow. Moldboard should be checked in all positions.
- E. Attach L.H. and R.H. Light Brackets (2&3) to the side plates of Lift Frame (22) in the upper two holes using 5/16"-18 x 1-1/4" bolts (14), 5/16" lockwashers (18), and 5/16"-18 hex nuts (19). **Note:** Light brackets may be adjusted down two levels in height for better appearance on lower profile vehicles. Tighten all fasteners to their proper torque. Refer to Torque Chart on next page.
- F. Attach lift arm (7) to lift frame (22) using

**Figure 3**

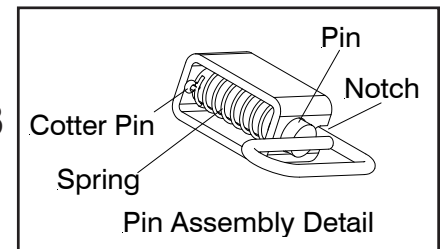

5/8-11 x 5-1/2" bolt (11) and 5/8-11 locknut (12). Mount Hydraulic unit to lift frame (22) using 5/8-11 x 3-1/4" bolt (9) and 5/8-11 locknut (12) and to lift arm (7) using 5/8-11 x 5" bolt (10) and 5/8-11 locknut (12).

- G. Install hydraulic system and light system per separate instructions.
- H. Pre-Assemble Moldboard Assembly per separate instructions.
- I. To store Crankstand (6) on the Lift Frame (22) slide the tube that is attached to the side of the Crankstand (6) over the transport tube on the driver's side of the Lift Frame. Insert the chained locking pin through the vertical holes on both the tubes. **Note: Crankstand (6) should always be fully retracted (up) and be pinned in the vertical transport position when not in use.** Receiver Tube Cap (5) may be placed over the driver side transport tube while the Crankstand (6) is in use on the A-Frame. The Receiver Tube Cap (5) may also be switched over to the Adjustment Tube of the A-Frame when the Crankstand is mounted to the Lift Frame.
- J. Attach A-Frame to Lift Frame (22) by connecting Crankstand (6) to the adjustment tube in the center of the A-Frame. Insert the chained locking pin all the way through the vertical holes on both the tubes. Crank up A-Frame until the holes on the back ears of the A-Frame are about 12" off the ground per Figure 2. Pull truck up to the A-Frame/Moldboard assembly aligning the A-Frame ears between the two lift frame plates until contact is made with the Clevis Frame (1). Once you feel contact, push the moldboard assembly a few inches forward, this insures proper alignment so that the A-Frame is square to the Clevis Frame. Adjust the Crankstand up until the front of the truck raises slightly. Attach Lift Frame (22) to A-frame using 1" Dia Pin (21) and Cotter Pin (20). **Note:** If pins do not properly engage move the truck slightly forward a few more inches and/or adjust (raise or lower) the Crankstand until pins slide into place. If only one pin should engage, retract the stand to the full upright position. Remove the Crankstand from the A-frame by removing the chained locking pin. Reattach the Crankstand to the transport tube on the driver's side of the Lift Frame in the vertical transport position. Attach lift chain as per paragraph "K" below. Raise the plow with the hydraulics and swing the moldboard slightly left or right until the pin will slide into place.

**Storage of the Crankstand (6) is the responsibility of the operator. The stand can be stored on the lift frame in the retracted position (per Figure 1) to the driver's side transport tube or inside the vehicle cab.**

- K. Attach the Lift Chain to the Lift Arm (7) through the

two hooks on the lift arm. Adjust the lift chain at the lift arm so that there are 2-3 links of slack. This ensures that the plow blade will lift fully and be able to follow the ground contour while plowing.

#### DETACHING THE COMPLETE ASSEMBLY

Leave control switch in lower float position and push down on the Lift Arm (7). Disconnect the electrical plug and slip on weather caps over the both ends. Attach Crankstand to the adjustment tube in the center of the A-Frame using the chained locking pin. **Caution: Crankstand must be secured at all times.** Adjust the Crankstand down until the bottom of stand touches the ground. Pull and twist the two Blue Handle Pins (4) to disengage. If the pins do not pull easily, adjust stand up or down slightly to remove tension on the pins until they disengage. At this time the lift frame should be leaning forward slightly, at rest on the top of the Crankstand. Pull truck away.

#### DETACHING MOLDBOARD ASSEMBLY ONLY



Leave control switch in lower float position and push down on the Lift Arm (7). Disconnect hydraulic couplers and Lift Chain from Lift Arm. Attach Crankstand to the adjustment tube in the center of the A-Frame using the chained locking pin. **Caution: Crankstand must be secured at all times.** Adjust the Crankstand down until the bottom of stand touches the ground. Remove Cotter Pins (20) and remove 1" Dia Pins (21) to disengage. If the pins do not pull easily, adjust stand up or down slightly to remove tension on the pins until they disengage. Pull truck away.

#### ATTACHING THE COMPLETE ASSEMBLY

Check that the Blue Handle Pins are disengaged. Drive the truck up to the E-Z Mount Plus™ assembly centering the hood of the truck to the lift arm to assure proper alignment with lift frame guide plates until contact is made. Once contact is made drive forward, pushing the assembly a few inches. This insures the A-Frame is square to the Clevis Frame for proper pin attachment. Adjust the Crankstand up until the front of the truck raises slightly. The rear fixed Pins should now be aligned with the rear notched hole on the clevis frame (1). Twist both Blue Handle Pins so that the small leg realigns with the slot, push the top of the Lift Frame towards the truck locking the front pins to the clevis frame. Remove the Crankstand from the A-frame by removing the chained locking pin. Reattach the Crankstand to the transport tube on the driver's side of the Lift Frame in the vertical, retracted position. **Caution: Crankstand must be secured at all times.**

Reattach the one step electrical connection.

#### TORQUE CHART FOOT LBS.

| Bolt Nut Size | Gr. 2  | Gr. 5  | Gr. 8  |
|---------------|---|---|---|
| 1/4 - 20      | 4 - 5   |   |   |
| 5/16 - 18     | 9 - 11  |   |   |
| 3/8 - 16      | 17 - 20   | 26 - 29   |   |
| 7/16 - 14     |   | 42 - 46   | 60 - 66   |
| 1/2 - 13      |   | 64 - 72   | 90 - 100  |
| 5/8 - 11      |   | 127 - 141   | 179 - 198   |
| 3/4 - 10      |   | 227 - 251   |   |

Meyer Products assumes no responsibility for installations not made in accordance with these instructions.