

PARTS & INSTALLATION INSTRUCTIONS

DRIVE PRO™

UNIVERSAL CLEVIS AND LIFT FRAME (CLF) W/CRANKSTAND

FOR VEHICLE 1/2 TON OR SMALLER USING THE E-Z MOUNT PLUS MOUNTING SYSTEM

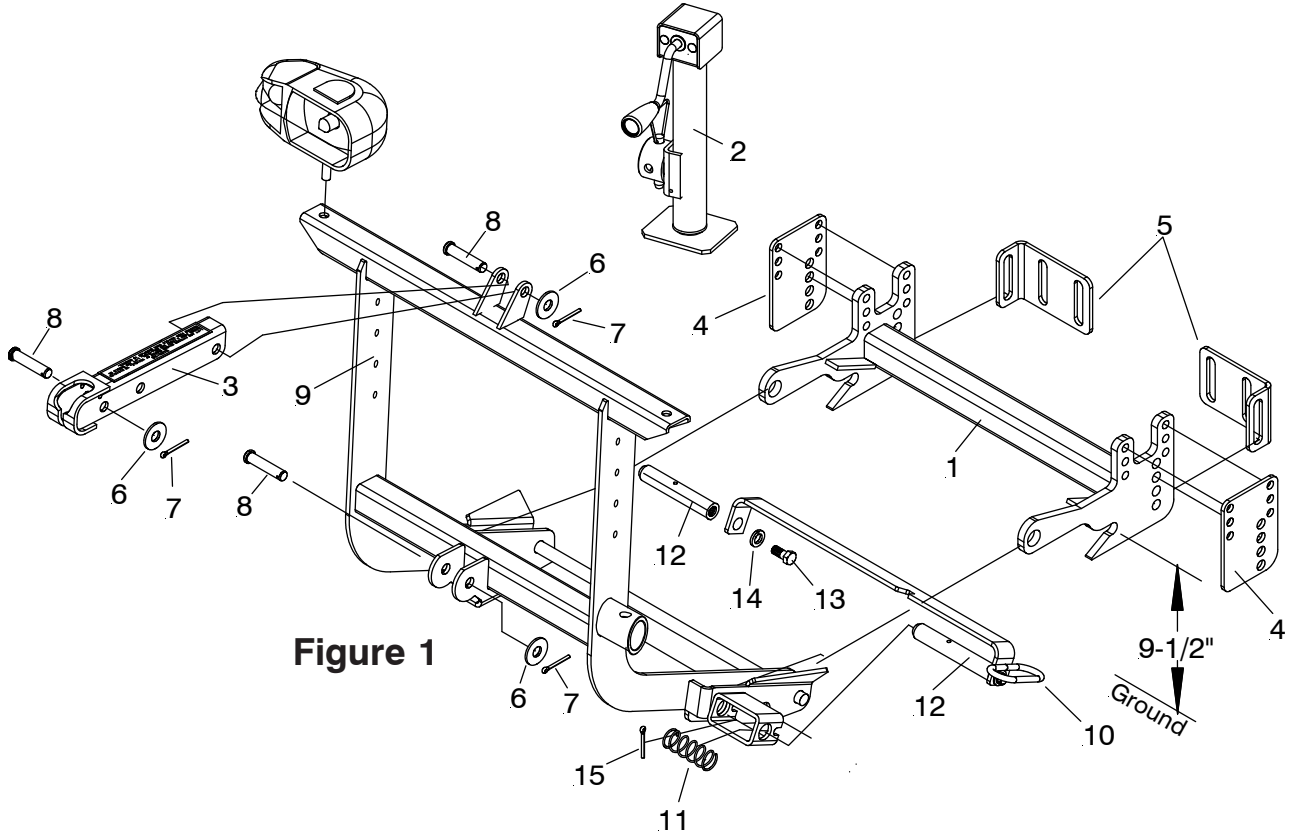

Figure 1

PARTS LIST

Item	Part No.	Qty.	Description
	16604	1	Drive Pro™ CLF Assembly
	16603	1	• Drive Pro™ Clevis Carton
1	19943	1	•• Drive Pro™ Clevis Frame
2	22245	1	•• Crank Stand
3	10514	1	•• Lift Arm
4	19945	2	•• Drive Pro Clevis Spacer
5	19948	2	•• Clevis Support Bracket
	08142	1	•• MOUNTING HARDWARE BAG
6	20357	3	••• Flatwasher 5/8"
7	20385	3	••• Cotter Pin 1/8 x 1-1/4"
8	22719	3	••• Pivot Pin
	18981	1	• Lift Frame Assembly
9	18980	1	• Lift Frame
10	19781	1	• Handle Pin
11	814000005	1	• Spring
12	19775	2	• Pin
13	22010	2	• Bolt H 3/8-16 x 1-1/4" Patch
14	22260	2	• Poly Washer 3/8"
15	20406	1	• Cotter Pin 3/16 x 1-1/2"

Parts indented are included in the carton, bag or assembly under which they are indented.

Meyer Products LLC reserves the right, under its continuing product improvement program, to change construction or design details, specifications and prices without notice or without incurring any obligation.

Meyer Products LLC
18513 Euclid Ave. • Cleveland, Ohio 44112-1084
Phone (216) 486-1313
www.meyerproducts.com • email info@meyerproducts.com

GENERAL INFORMATION

CAUTION: Always disconnect battery before beginning installation.

DO NOT BURN holes or **WELD** vehicle frame. This may cause frame failure.

After first use, re-tighten all mounting bolt connections to specified torque. All mounting bolt connections to be checked periodically for tightness.

Locknuts are furnished **DO NOT** tighten bolts and nuts until installation is complete (unless otherwise specified), then be sure to tighten all attaching parts per specified torque chart.

NOTE: It is important that the Meyer harness, all wires from the Meyer light switch, and all other electrical wires be routed around hot or moving engine parts, and any sharp metal. Protection must be provided to guard against wire damage at these points. All excess or loose wires must be neatly secured using wire ties. Check contents against the parts list to determine all are correct and included, and also to familiarize yourself with them.

SAFETY PRECAUTIONS should be used when **Hydraulic Unit is in OPERATION** and plow is in a **RAISED** position. **Lower plow to ground when vehicle is PARKED.**

OVERHAUL and **SERVICE INFORMATION** are covered on separate instructions.

Follow these instructions explicitly. Warranty does not apply to a Meyer product which has been negligently or improperly assembled or installed.

INSTALLATION INSTRUCTIONS

A. Assemble Clevis Frame (1) to vehicle per separate Mounting Carton Instructions. Use the holes on the Clevis Frame (1) that will put the rear slot closest to 9-1/2" from the ground as shown. Spacer (4) and Bracket (5) will be needed as shown.

B. Note: Handle Pin has been pre-assembled to the Lift Frame. Assemble Pin (12) to Handle Pin (10) using 3/8-16 x 1-1/4" Bolt (13) and 3/8" Poly washer (14). Only tighten until head of bolt begins to touch poly washer. Assemble to Lift Frame (9) by inserting the Pin (12) through the Lift Frame plates, through the center of the spring (11). Compress the spring (11) slightly with your fingers and insert the 3/16" x 1-1/2" Cotter Pin (15) through the small hole towards the center of the pin. With cotter pin (15) fully inserted, bend the cotter pin in place. Align the notch on the Handle Pin (10) to Lift Frame (9) to lock in place (disengaged). **Note: Lubricate the stainless steel pins and Lift Frame bearing surfaces with chassis grease or anti-seize lubricant periodically for easier disengagement of pins.**

C. Slide Crank Stand (2) to the receiver tube on the Lift frame (9). Pin Crankstand (2) to the Lift Frame (9).

D. Attach Lift Frame (9) to Clevis Frame (1) (Ref. Figure 1). Twist the Handle Pin so that the two Pins (12) engage. The spring loaded pin should snap into place locking the lift frame to the clevis frame.

E. Attach Lift Arm (3) to Lift Frame (9), Mount Hydraulic unit to lift frame (9) and to lift arm (3) using Pivot Pin (8), 5/8" Washer (6) and 1/8 x 1-1/4" Cotter Pin (7).

F. Install hydraulic system and light system per separate instructions.

G. Pre-Assemble Moldboard Assembly per separate instructions.

H. Attach the Lift Chain to the Lift Arm (3) through the hook on the lift arm. Adjust the lift chain at the lift arm so that there are 2-3 links of slack. This ensures that the plow blade will lift fully and be able to follow the ground contour while plowing.

DETACHING THE COMPLETE ASSEMBLY



Leave control switch in lower float position and push down on the Lift Arm (3). Disconnect the electrical plug and slip on weather caps over the both ends. Attach Crankstand to the adjustment tube in the center of the A-Frame using the chained locking pin. **Caution: Crankstand must be secured at all times.** Adjust the Crankstand down until the bottom of stand touches the ground. Pull and twist the Handle Pin (10) to disengage. If the pins do not pull easily, adjust stand up or down slightly to remove tension on the pins until they disengage. At this time the lift frame should be leaning forward slightly, at rest on the top of the Crankstand. Pull truck away.

ATTACHING THE COMPLETE ASSEMBLY

Check that the Handle Pin is locked open. Drive the truck up to the Drive Pro Plow Assembly assembly centering the hood of the truck to the lift arm to assure proper alignment with lift frame guide plates until contact is made. Once contact is made drive forward, pushing the assembly a few inches. This insures the A-Frame is square to the Clevis Frame for proper pin attachment. Adjust the Crankstand up until the front of the truck raises slightly. The rear fixed Pins should now be aligned with the rear notched hole on the clevis frame (1). Twist the Handle Pin so that the spring begins to push the pins into the Lift Frame (9). Push the top of the Lift Frame towards the truck locking the front pins to the clevis frame. Remove the Crankstand from the A-frame by removing the chained locking pin. Reattach the Crankstand to the transport tube on the driver's side of the Lift Frame in the vertical, retracted position. **Caution: Crankstand must be secured at all times.**

Reattach the one step electrical connection.

TORQUE CHART FOOT

Bolt Nut Size	Gr. 2 	Gr. 5 	Gr. 8 
1/4 - 20	4 - 5		
5/16 - 18	9 - 11		
3/8 - 16	17 - 20	26 - 29	
7/16 - 14		42 - 46	60 - 66
1/2 - 13		64 - 72	90 - 100
5/8 - 11		127 - 141	179 - 198

Meyer Products assumes no responsibility for installations not made in accordance with these instructions.