

Hiniker Company
58766 240th St.

P.O. Box 3407
Mankato, MN 56002

INSTALLATION INSTRUCTION SHEET FOR:
FORD RANGER 4x4 1996 - 2011

INSTRUCTION SHEET NO: 25012061 Rev. A

April 10, 2012



IMPORTANT: Read the Snowplow Operator's Manual before assembling this kit.

REAR BALLAST -
150 lbs. when plow is attached.
Secure Weight Behind Rear
Wheels.

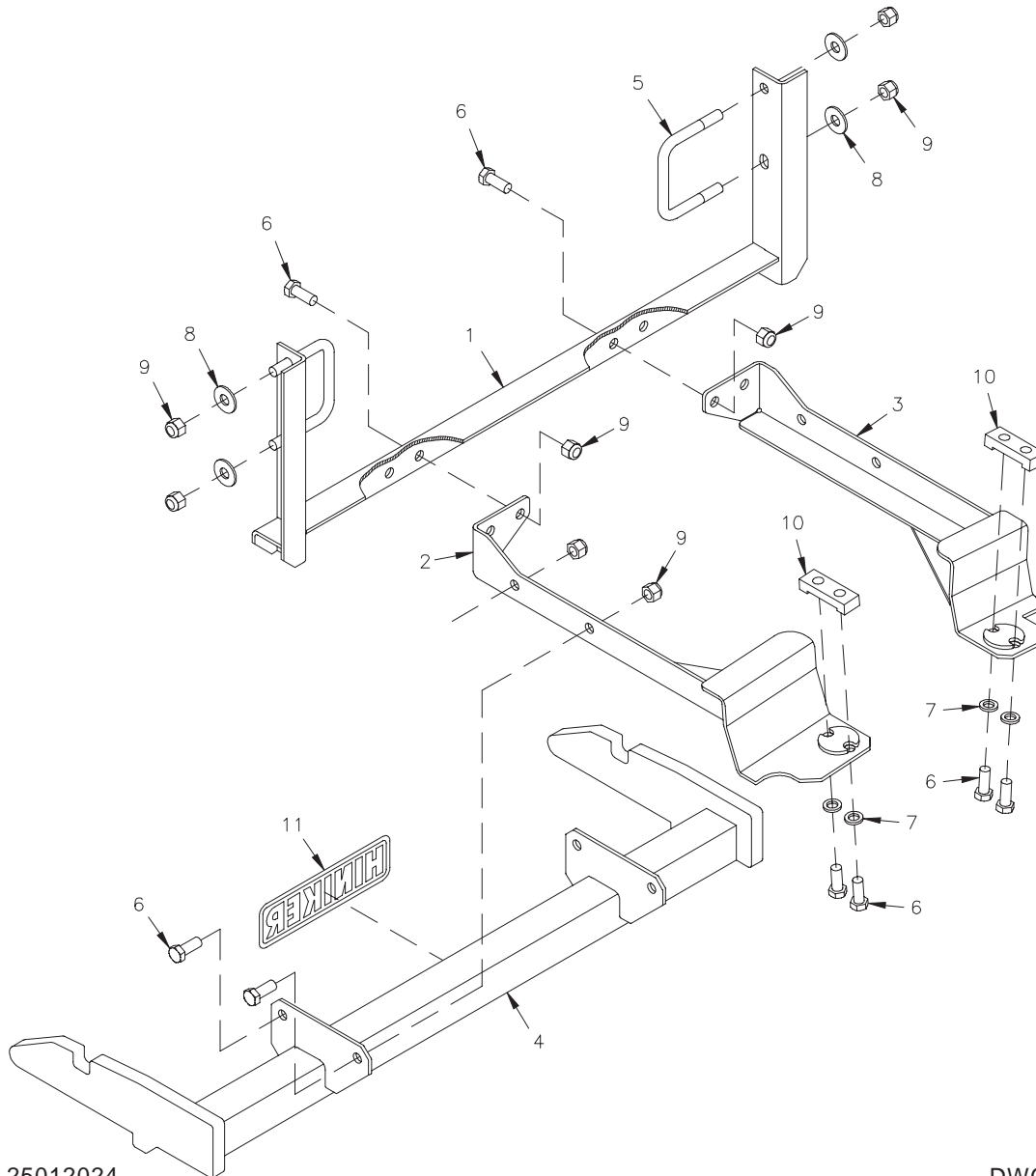

Mount Kit 25012024

DWG. NO. 5833

REF. NO.	PART NUMBER	DESCRIPTION	QTY.	REF. NO.	PART NUMBER	DESCRIPTION	QTY.
1	25012062	Front Frame Weldment	1	7	952-001-004	Lock Washer 1/2 Inch	4
2	25012063	LH Bracket Weldment	1	8	952-002-005	Flat Washer 1/2 Inch	4
3	25012064	RH Bracket Weldment	1	9	951-003-009	Lock Nut 1/2-13 Nylon Insert	12
4	25012065	Prong Weldment	1	10	25012067	Nut Bar	2
5	25012066	U-Bolt 1/2-13 x 4 1/4 x 3 1/2	2	11	25010008	Hiniker Decal	1
6	950-001-111	Hex Head Cap Screw 1/2-13 x 1 1/4 Gr. 5	12		25012069	Bolt Bag	1

All hardware should be tightened only enough to ensure safety during assembly. Fully tighten all hardware after entire assembly is completed.

GRADE 5 TYPE B & F LOCK NUT TORQUE VALUES

Size	Ft-lbs.	N-m
5/16"	13-18	17-25
3/8"	23-33	31-44
1/2"	58-82	79-112
5/8"	117-165	158-223

GRADE 5 BOLT TORQUE VALUES*

Size	Ft-lbs.	N-m
1/4"	8-12	11-16
3/8"	29-41	39-56
1/2"	73-103	99-140
5/8"	146-206	198-279

* applications without lock nuts

1. Place a U-bolt from the mount kit around each frame rail on the truck from the in-board side out, ahead of the radiator.



PHOTO NO. DCP0227

Identify the front and back orientation of the front frame weldment from the photo or front page illustration.

Lift the frame to the outside of the vehicle rails and insert the two U-bolts through holes in the vertical members. Loosely install 1/2 inch flat washers and lock nuts on the U-bolts to hold the frame in place.

2. Insert the two nut bars from the kit into each end of the vehicle's front crossmember to match the large round holes through the bottom of the crossmember. On the passenger side of the truck, place the nut bar over the outermost large hole.



PHOTO NO. 4219

Install the nut bars so the notched surfaces are directed down and the two tapped holes are aligned front to back relative to the truck.

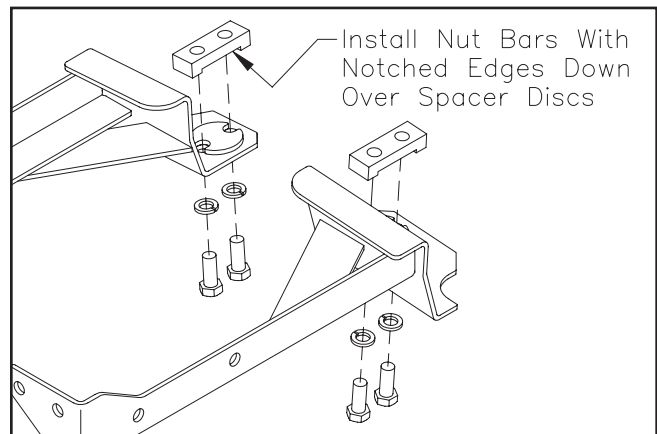

DWG. NO. 5834

Assemble the LH and RH side bracket weldments to the vehicle by aligning the two holes through the rear of the brackets with nut bars in the vehicle crossmember and bolting in place with 1/2 inch x 1 1/4 inch hex bolts and lock washers.



PHOTO NO. DCP0220

Important: Be sure that spacer discs on the side brackets are fully contained in the vehicle crossmember holes before final tightening of the hardware in Step 4.

Slide the front frame weldment and U-bolt assembly rearward on the vehicle rails until four holes in the frame weldment match the front sets of holes in the side brackets.



PHOTO NO. DCP0221

Fasten the side brackets to the front frame weldment with four 1/2 inch x 1 1/4 inch hex bolts and lock nuts.

3. Fasten the mount plates of the prong weldment to holes in the LH and RH side brackets with four 1/2 inch x 1 1/4 inch hex bolts and lock nuts.



PHOTO NO. DCP0216

Bottom edges of the prongs should measure about 10 inches above the ground when completed.

4. Assure that the front frame weldment hangs straight down and that spacer discs on the LH and RH side brackets are fully contained in vehicle crossmember holes. Fully tighten all hardware to specified torque values.