

# 28027-3 In-Line Adapter Kit

## Installation Instructions

### ⚠ CAUTION

This adapter is required for vehicles equipped with a 4-headlamp lighting system that illuminates the low *and* high beams when in high-beam mode. This adapter prevents the low beams on the snowplow from illuminating when placed in high beam.

1. Install the vehicle control harness and plug-in harness(es) according to the isolation module Installation Instructions.
2. Plug the 10-position female connector of the in-line adapter into the isolation module as shown below.

3. Connect the 10-position female connector of the vehicle lighting harness to the 10-position male connector of the in-line adapter.
4. Connect ring terminal to NEGATIVE (-) battery terminal.

**NOTE: If ring terminal wire does not reach battery, lengthen wire as required.**

5. To complete the installation, secure the relay assemblies to an existing assembly using cable ties. Mount the relay connectors wire side down.

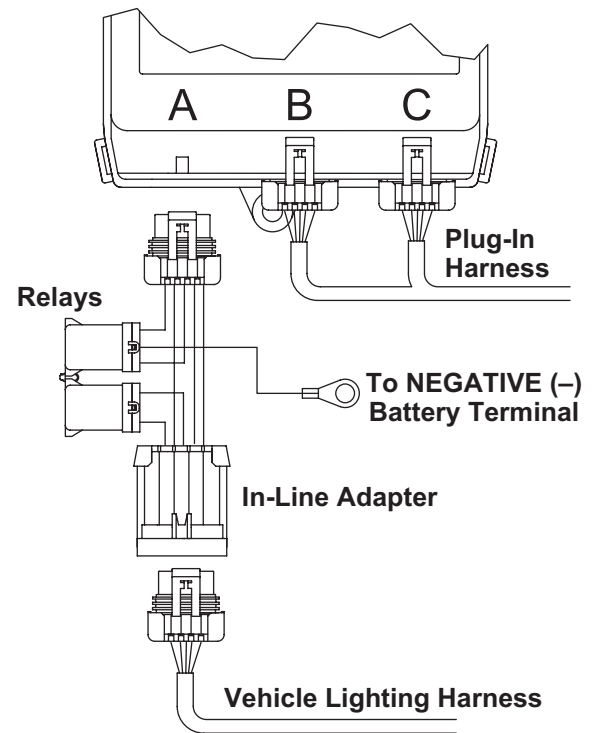
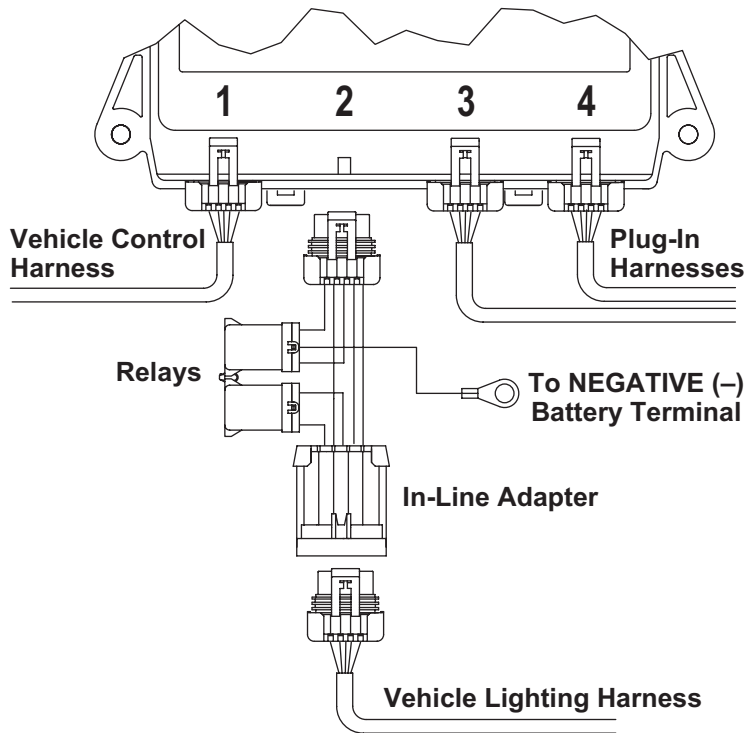

The company reserves the right under its product improvement policy to change construction or design details and furnish equipment when so altered without reference to illustrations or specifications used. This equipment manufacturer or the vehicle manufacturer may require or recommend optional equipment for snow removal. Do not exceed vehicle ratings with a snowplow. The company offers a limited warranty for all snowplows and accessories. See separately printed page for this important information.

**Printed in U.S.A.**

---