

Installation Instructions

Safety

- Always follow the vehicle manufacturer's recommendations relating to system installation. For recommended vehicle models, refer to the *BOSS Snowplow Application Chart and Selection Guide*.
- Never disable, remove, or relocate any sensors or other components related to the operation of the air bags.
- To comply with federal regulations and to assure a safe vehicle, do not exceed the front gross-axle-weight rating (FGAWR), rear gross-axle-weight rating (RGAWR), and the gross-vehicle-weight rating (GVWR) at any time.
- Due to the variety of equipment that you can install on the vehicle and undercarriage, do not exceed the front gross-axle-weight rating (FGAWR), rear gross-axle-weight rating (RGAWR), and the gross-vehicle-weight rating (GVWR) at any time. This may require weighing the vehicle and adding ballast as necessary. It may also limit the payload capacity of the vehicle.

Installation

Determine the left and right sides of the machine from the normal operating position.

1. Park the machine on a level surface, shut off the engine, wait for all moving parts to stop, engage the parking brake, and remove the key.
2. Remove the front bumper of the vehicle.
3. Remove the vehicle tow hook fasteners.
4. Install the pushbeam support plates, on both sides, as shown in [Figure 1](#).

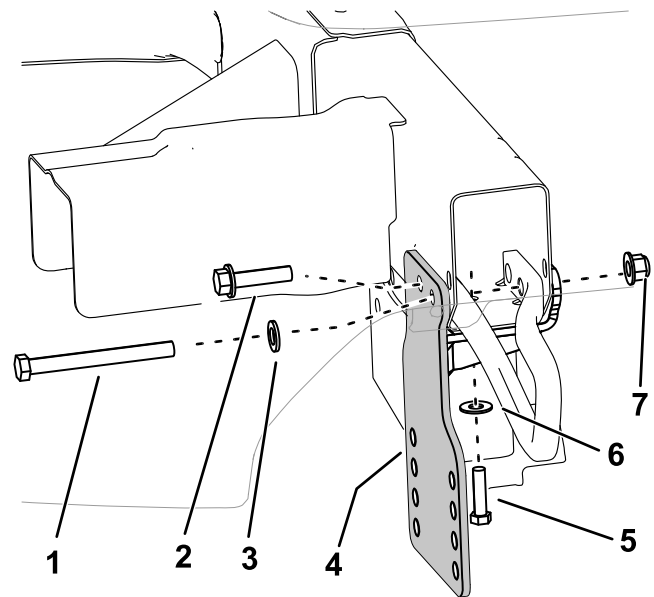

Figure 1

g258521

- | | |
|--------------------------------|--------------------------------|
| 1. Bolt – M12 x 120 mm (2) | 5. Bolt–3/8-16 x 1-12 inch (2) |
| 2. Bolt –M12 x 50 mm (2) | 6. Washer–3/8 inch (2) |
| 3. Washer–M12 (2) | 7. Nut–M12 (2) |
| 4. Pushbeam support plates (2) | |

5. Remove, cut, or trim the lower portion of the bumper fascia where the pushbeam hooks protrude.
6. Install the pushbeam as shown in [Figure 2](#).

Note: Refer to your plow *Owner's Manual* for the appropriate pushbeam height.



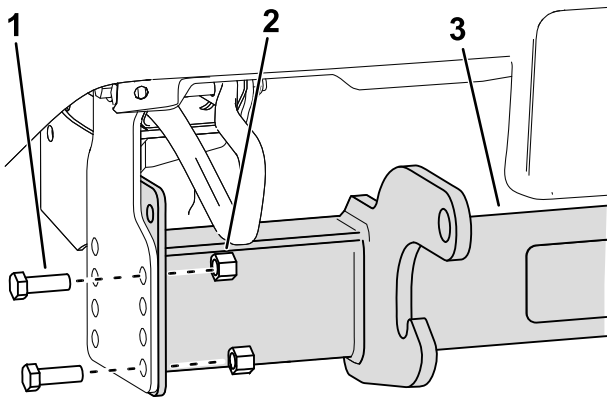

g258522

Figure 2

1. Bolt (1/2-13 X 1-1/2 inch); 3. Pushbeam
qty 4
2. Nut (1/2 inch); qty 4

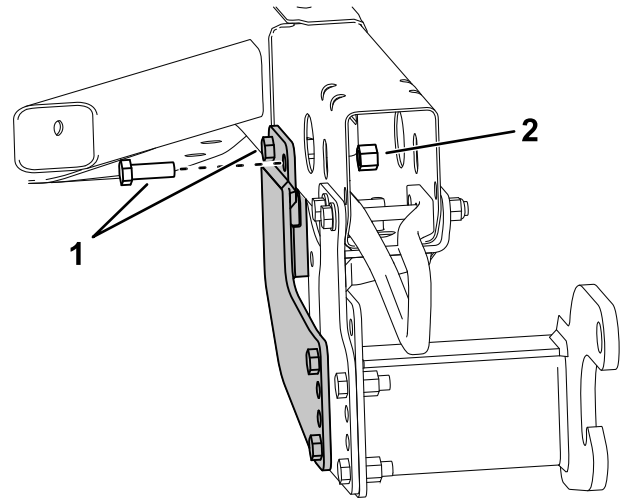

g258524

Figure 4

1. Bolt (1/2-13 X 1-1/2 inch); 2. Nut (1/2 inch); qty 4
qty 4

7. Secure the lower portion of the angle brackets, on both sides, as shown in [Figure 3](#).

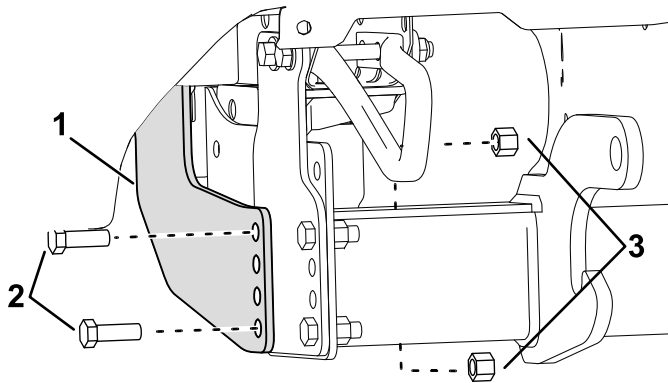

g258523

Figure 3

1. Bolt (1/2-13 X 1-1/2 inch); 3. Nut (1/2 inch); qty 4
qty 4
2. Angle bracket; qty 2

11. Torque all the fasteners, in this order, to the following specifications: 76 N·m (56 ft-lb).
 - Pushbeam support plates to the pushbeam ([Figure 2](#)): 91 to 113 N·m (67 to 83 ft-lb).
 - Pushbeam support plates to the frame (tow hook bolts) ([Figure 1](#)): 83 to 103 N·m (112 to 140 ft-lb).
 - Angle brackets ([Figure 3](#) and [Figure 4](#)): 91 to 113 N·m (67 to 83 ft-lb).
12. Install the previously removed front bumper.

Note: To prevent damage to the grille shutters and wire harnesses, do not route wire harnesses through the grill area.

Route wire harnesses horizontally across the upper radiator support or vertically between the vehicle headlights and radiator.

Note: Do not make direct-to-battery connections at the negative battery post.

Make negative battery connections at the auxiliary negative post on the sidewall on the engine compartment.

8. Mark the upper holes of the angle brackets.
9. Remove the angle brackets and drill the 4 9/16 inch holes.
10. Install the angle brackets ([Figure 4](#)).

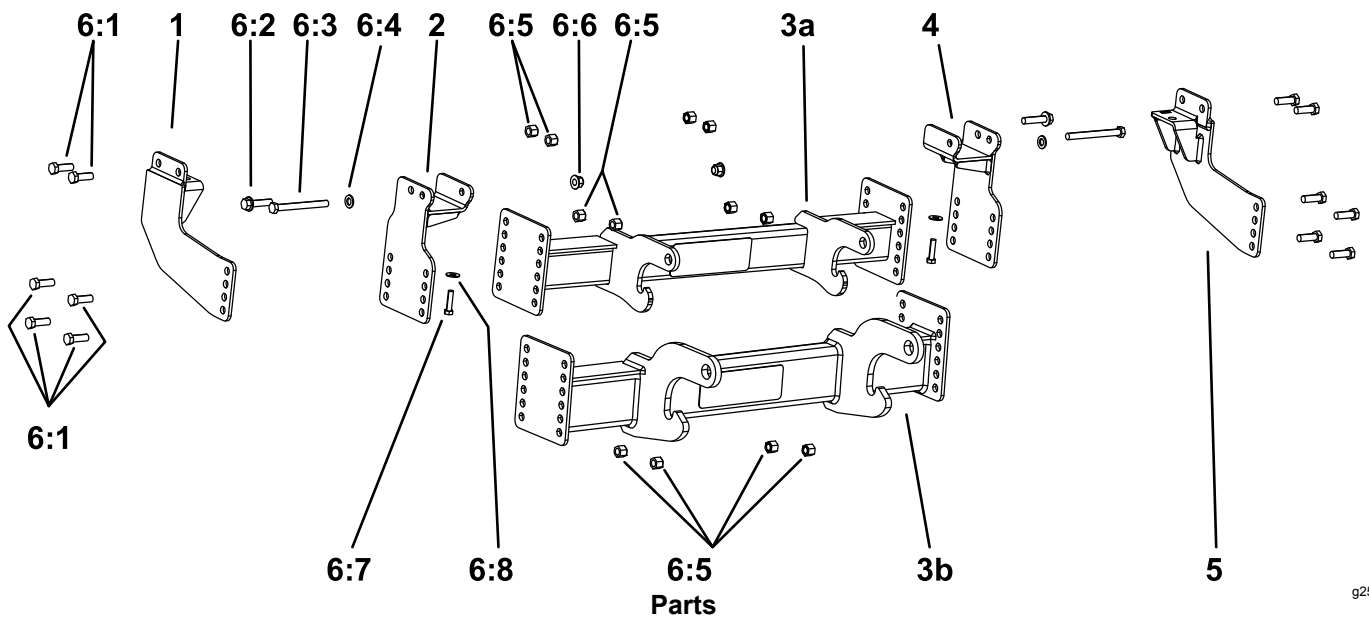

g258520

Ref.	Part Number	Qty.	Description
1	LTA11230-03	1	ANGLE BRACKET
2	PBA11221-03	1	PUSHBEAM SUPPORT BRACKET
3a	PBA11215-03	1	RT3 PUSHBEAM
3b	PBA11225-03	1	HTX PUSHBEAM
4	PBA11220-03	1	PUSHBEAM SUPPORT BRACKET
5	LTA11231-03	1	ANGLE BRACKET
6:1	HDW01728	12	1/2" - 13 X 1-1/2" HEX HEAD BOLT GR 5
6:2	HDW08977	2	BOLT,HEX,FLANGE,M12X1.75X50MM,ZINC
6:3	HDW11236	2	HHCS,M12X1.75X120MM,CL10.9,YZN
6:4	HDW11237	2	WASHER,FLAT,M12,YZN
6:5	HDW01748	12	1/2" - 13 HEX HEAD NYLON LOCK NUT
6:6	HDW11238	2	NUT,NYLOCK,FLANGE,M12X1.75MM,CL10,YZN
6:7	HDW01837	2	HHCS,3/8-16X1-1/2,YZN
6:8	HDW01733	2	WASHER,3/8,USS FLAT,YZN
6	HDW11212	1	FASTENER KIT

BOSS
S N O W P L O W