



SNOWFLOW

M.I. ELECTRIC, INC.

P.O. BOX 788 • IRON MOUNTAIN, MICHIGAN 49801

1991 AND OLDER FORD (DIESEL) UNDERCARRIAGE MOUNTING INSTRUCTIONS (PART NO. LTA2521)

TABLE OF CONTENTS

UNDERCARRIAGE MOUNTING INSTRUCTIONS	2
PUSH BEAM ASSEMBLY PARTS LIST (FIGURE 1).....	3
UNDERCARRIAGE PARTS LIST (FIGURE 3).....	5
DIESEL ANGLE BRACKET ASSEMBLY INSTALLATION PARTS LIST	6
TORQUE CHART (FIGURE 5).....	7
LIFT SYSTEM AND HEADLIGHT INSTALLATION INSTRUCTIONS	10
LIFT SYSTEM AND LIGHT BRACKET INSTALLATION PARTS LIST	11
DIESEL PUMP BRACKET INSTALLATION	12
ALTERNATE METHOD OF ATTACHING THE RAPID-TACH RELEASE CABLE.....	13
TWO YEAR WARRANTY	14

PUTS SNOW IN ITS PLACE

FORD (DIESEL)
PART NO. LTA2521
7'6", 8'2", AND 9'2" MODELS
UNDERCARRIAGE MOUNTING INSTRUCTIONS

The mounting procedure outlined below covers FORD (Diesel) trucks. You will need to refer to the illustrations and familiarize yourself with each of the undercarriage components and their relative position to each other. Then proceed as follows:

1. Remove the truck bumper and bumper brackets.
2. Position the LIFT TOWER ASSEMBLY (Ref. No. 74, Fig. 3) to the front frame rails of the truck. Using hex head bolts, flat washers, and self locking nuts provided bolt the LIFT TOWER ASSEMBLY to the front frame rails (Ref. Figure 6). Fasteners should only be finger tight.
3. Assemble the PUSH BEAM ASSEMBLY (Ref. No. G, Fig. 1) as shown.
4. Attach the PUSH BEAM ASSEMBLY to the LIFT TOWER ASSEMBLY as shown in Figure 3 using hex head bolts and self locking nuts, fasteners should only be finger tight. To determine the mounting height of the PUSH BEAM ASSEMBLY see plow type below:

A) V-Plow Measure from the center of the HORIZONTAL MOUNTING PIN (See Figure 2) on the T-FRAME to the ground when the plow is in the vee position. Position the PUSH BEAM ASSEMBLY to the appropriate height so the MOUNTING JAWS (See Figure 2) will accept the HORIZONTAL MOUNTING PIN on the T-FRAME.

NOTE: Should the PUSH BEAM ASSEMBLY be mounted higher than the HORIZONTAL MOUNTING PIN, the nose of the plow will tend to dig in while plowing. If the PUSH BEAM ASSEMBLY is mounted too low, the wings of the plow will not lay flat against the ground. This will be most apparent when plowing in the carry position.

B) Straight Blade Plow The distance from the ground to the top of the lower mounting jaw should be approximately 11-1/2" (See Figure 2).

5. Install RIGHT ANGLE BRACKET ASSEMBLY FRAME MOUNT (Ref. No. 75R, Fig. 4) and LEFT ANGLE BRACKET ASSEMBLY FRAME MOUNT (Ref. No. 75L, Fig. 4) as shown in Figure 4 using hex head bolts, and self locking nuts provided, fasteners should only be finger tight. Install ANGLE BRACKET ASSEMBLY (Ref. No. 75, Fig. 4) from the mounting points on the PUSH BEAM ASSEMBLY to their respective positions on the FRAME MOUNTS (see Figure 4) using hex head bolts and self locking nuts. fasteners should only be finger tight.

6. With all undercarriage parts in place, securely fasten all mounting hardware. IT IS IMPORTANT THAT FASTENERS BE PROPERLY TORQUED (SEE FIGURE 5) TO ASSURE A SAFE OPERATING PLOW.

7. Reinstall the front bumper directly to the LIFT TOWER ASSEMBLY as shown in Figure 3 for 1987 and newer Fords. For Fords prior to 1987 use the bumper adaptor brackets as shown in Figure 3.

With the above items completed, the hydraulic system can be installed. Refer to the HYDRAULIC Section for step by step instructions on how to install the HYDRAULIC PUMP, VALVE ASSEMBLY, HOSES, and CONTROL SWITCHES.

**PUSH BEAM ASSEMBLY
PARTS LIST (FIGURE 1)**

REF. NO.	DESCRIPTION	PART NO.	QTY.
A	Rapid-Tach Release Cable	MSC1512	1
B	Cable Stop	HDW1702	1
C	Rapid-Tach Pin	HDW1710	2
D	Rapid-Tach Spring	HDW1711	2
E	Cotter Pin	HDW1712	2
F	5/8" Flat Washer	HDW1726	4
G	Push Beam Assembly	PBA2101	1
H	Push Beam Release Strap	PBX0010	1

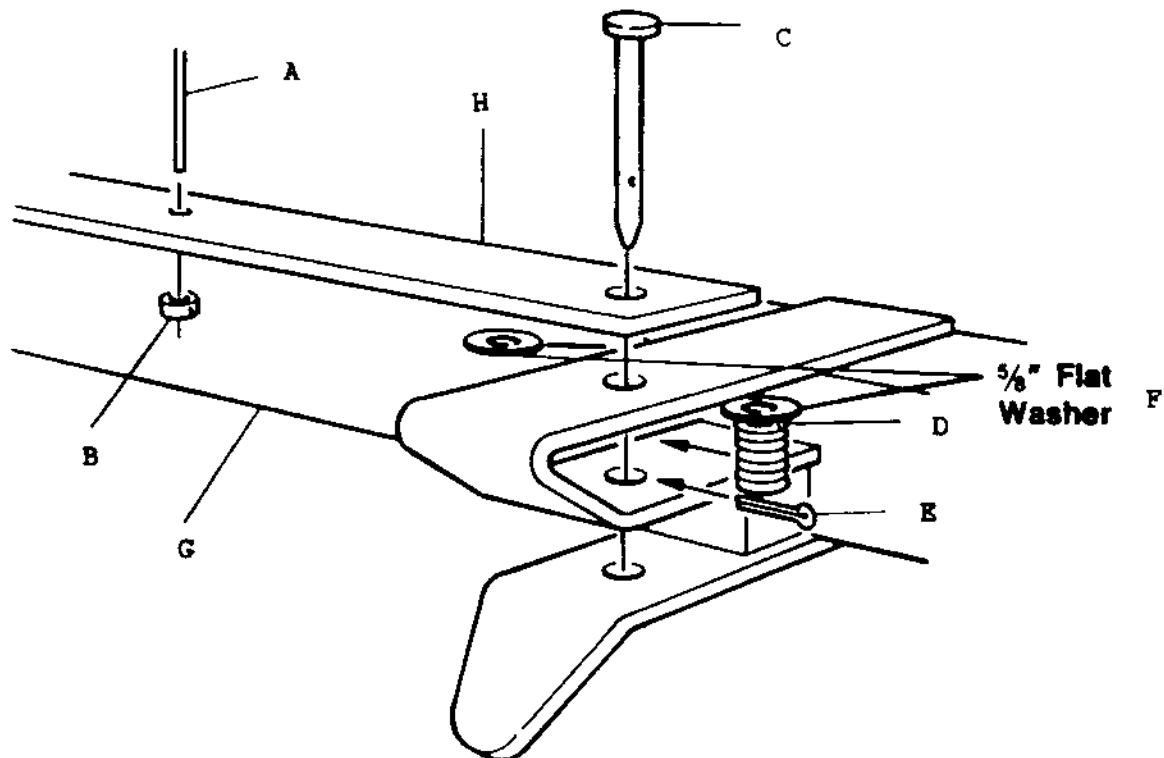

Figure 1

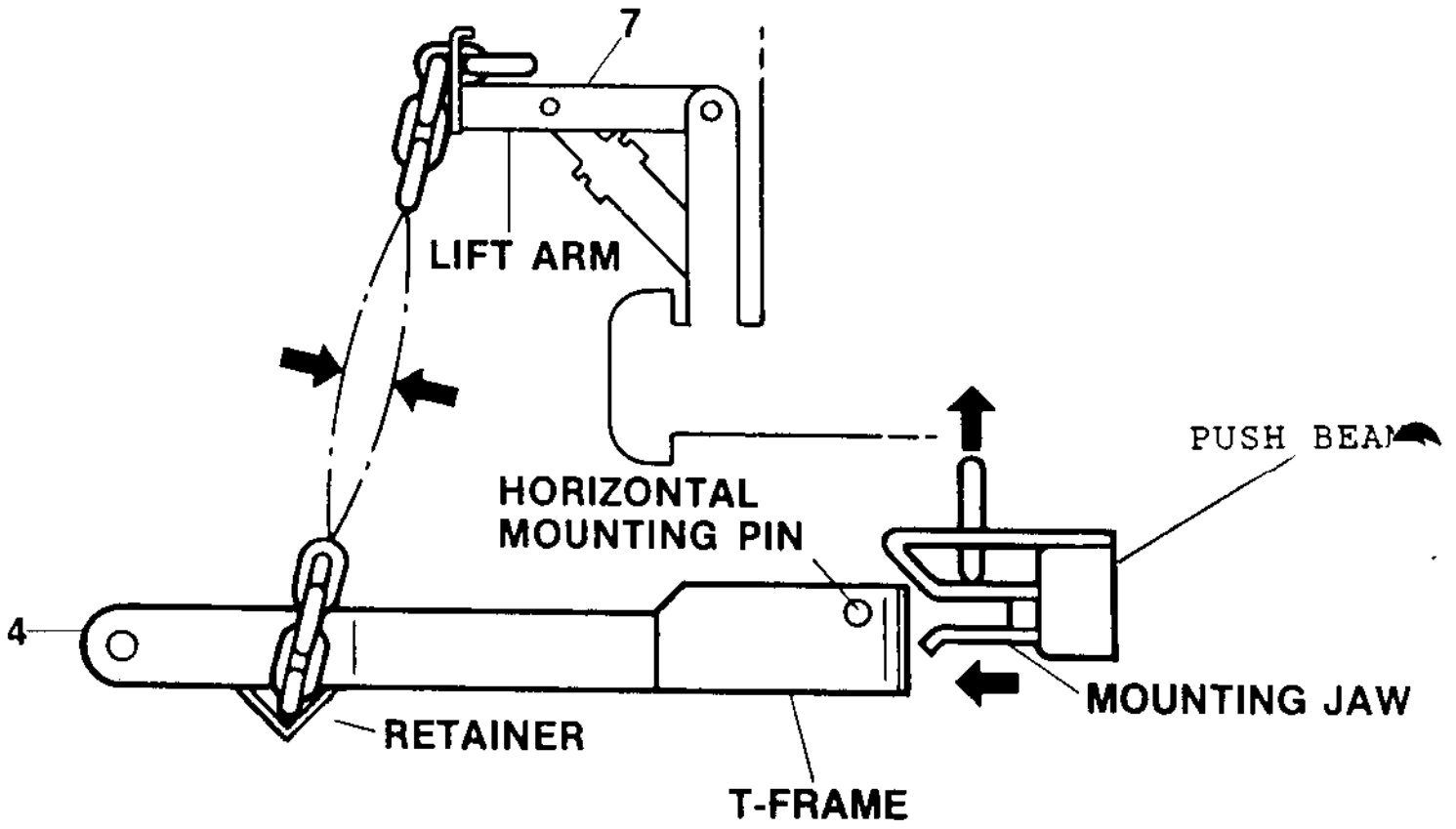

Figure 2

FORD (DIESEL)
PART NO. LTA2521
UNDERCARRIAGE PARTS LIST

REF. NO.	DESCRIPTION	PART NO.	QTY.
74	Lift Tower Assembly	LTA2500	1
62	Push Beam Assembly	PBA2101	1
77	Bumper Bracket (Prior to 1987)	LTA2508	2
A	5/8 x 4-1/2 Hex Head Bolt	HDW1705	1
B	5/8 x 4 Hex Head Bolt	HDW1706	1
C	5/8 Flat Washer	HDW1726	4
D	5/8 x 1-1/2 Hex Head Bolt	HDW1727	12
E	3/8 x 1 Hex Head Bolt	HDW1717	4
F	5/8 Self Locking Nut	HDW1709	14
G	3/8 Self Locking Nut	HDW1720	4
H	1/2 x 1-1/2 Hex Head Bolt	HDW1728	4
I	1/2 Self Locking Nut	HDW1703	4
J	1/2 Flat Washer	HDW1729	4

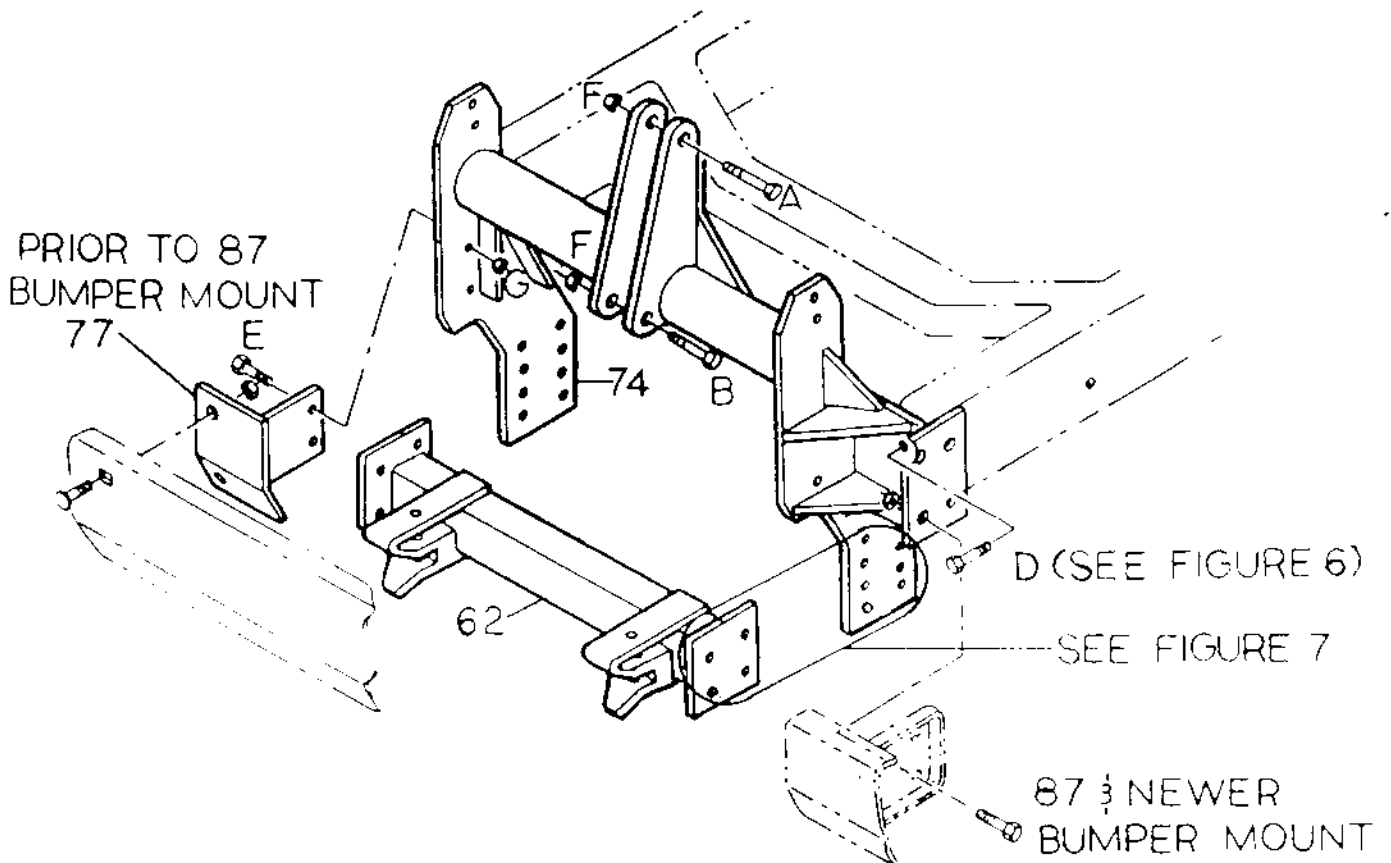

FIGURE 3

FORD (DIESEL)
 ANGLE BRACKET ASSEMBLY INSTALLATION
 PARTS LIST

REF. NO.	DESCRIPTION	PART NO.	QTY.
62	Push Beam Assembly	PBA2101	1
75	Diesel Angle Bracket Assembly	LTA2504	1
75L	Frame Mount (Left Hand)	LTA2530	1
75R	Frame Mount (Right Hand)	LTA2531	1
A	5/8 x 2 Hex Head Bolt	HDW1731	8
B	5/8 x 1-1/2 Hex Head Bolt	HDW1727	2
C	5/8 Self Locking Nut	HDW1709	10

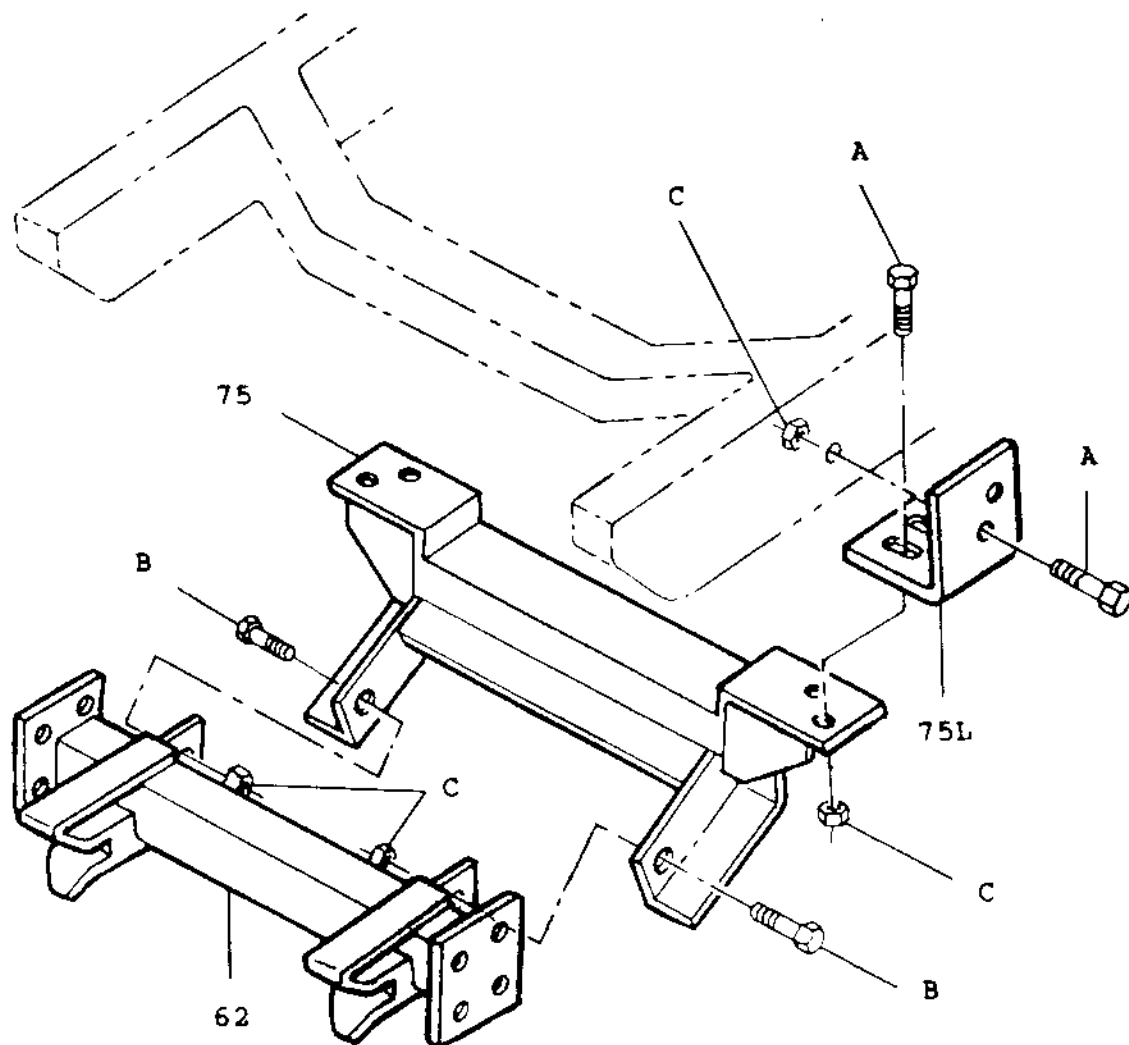
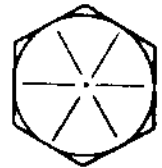

Figure 4

GUIDE TO RECOMMENDED ASSEMBLY TORQUE

All Torque Values Are In Foot-Pounds (Ft. - Lb.)



DIA./ PITCH	GRADE 5	GRADE 8
1/4 - 20	6	9
5/16 - 18	14	19
3/8 - 16	23	33
7/16 - 14	38	53
1/2 - 13	56	80
9/16 - 12	82	116
5/8 - 11	113	159
3/4 - 10	201	283

* The torque values listed above are based on dry, coated bolts, variables such as oil, or other lubrications may appreciably alter these values and must be taken into consideration.

NOTE: IT IS IMPORTANT THAT ALL FASTENERS BE PROPERLY TORQUED TO ASSURE A SAFE OPERATING PLOW.

Figure 5

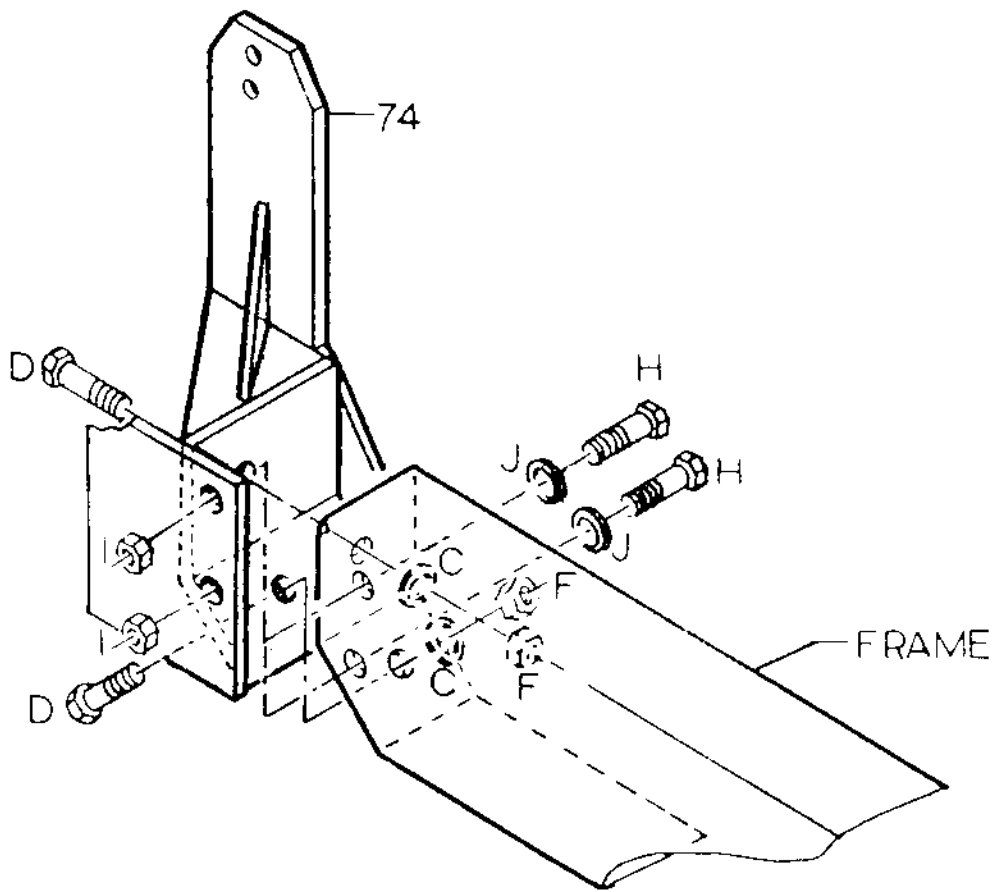

FIGURE 6

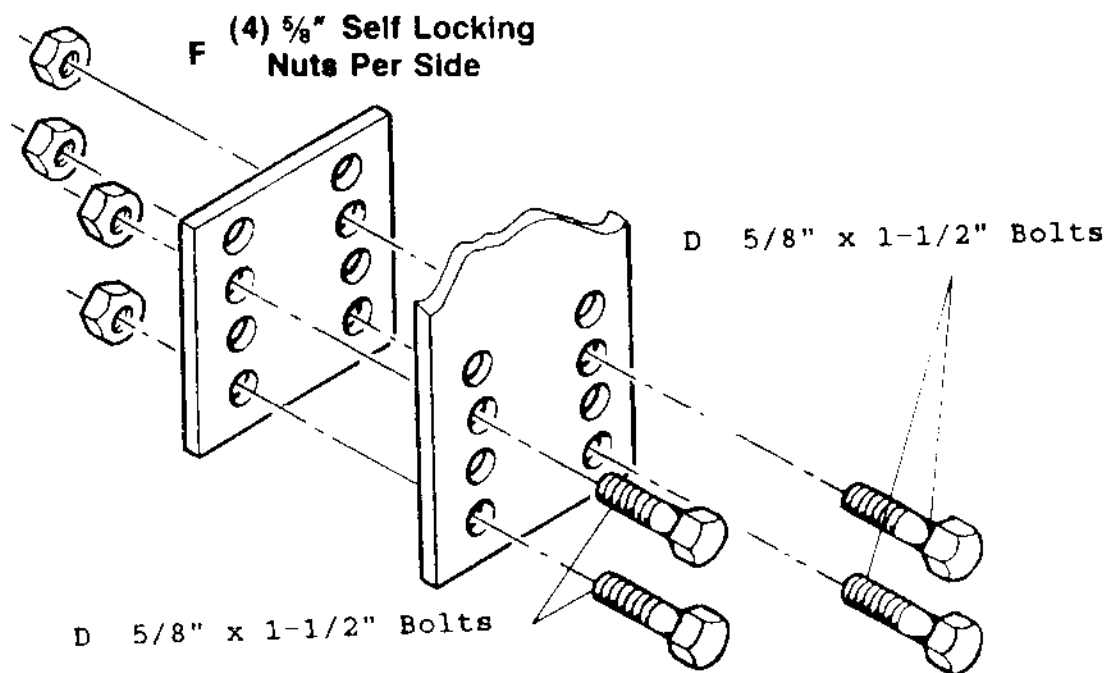

Figure 7

LIFT SYSTEM AND HEADLIGHT INSTALLATION INSTRUCTIONS

1. Install the AUXILIARY LIGHT BRACKETS (Ref. No. A, Fig. 8) to the LIFT TOWER as shown in Figure 8 using the hex head bolts and nuts provided.
2. Install LIFT ARM (Ref. No. B, Fig. 8) to the top of the LIFT TOWER ASSEMBLY using the 5/8" x 4-1/2" HEX HEAD BOLT (Ref. No. F, Fig. 8) and 5/8" SELF LOCKING NUT (Ref. No. I, Fig. 8) provided.
3. Position the LIFT CYLINDER (Ref. No. D, Fig. 8) in its respective position on the LIFT TOWER and fasten by using the 5/8" x 4" HEX HEAD BOLT (Ref. No. G, Fig. 8) and 5/8" SELF LOCKING NUT (Ref. No. I, Fig. 8) provided. Install the 90 DEGREE SWIVEL FITTING (Ref. No. E, Fig. 8). Fasten the rod end of the cylinder to the LIFT ARM using the 5/8" x 3-1/2" HEX HEAD BOLT (Ref. No. H, Fig. 8) and 5/8" SELF LOCKING NUT (Ref. No. I, Fig. 8) provided.
4. Mount the AUXILIARY HEADLIGHTS (Ref. No. C, Fig. 8) to the AUXILIARY LIGHT BRACKETS as shown in Figure 8. Do not tighten the AUXILIARY HEADLIGHT mounting nut as the positioning of the lights will have to be adjusted once the wiring has been completed.
5. A diagram has been provided in each Light Kit Box to illustrate the proper method of wiring the AUXILIARY HEADLIGHTS to the existing vehicle wiring harness.
6. Be sure to route all wires away from sharp obstructions and securely position them away from hot or moving parts.
7. Your AUXILIARY HEADLIGHT KIT comes with all of the necessary wiring, connectors and switch.
8. When the wiring of the AUXILIARY HEADLIGHTS has been completed, follow the Head Lamp Aiming instructions also provided in the Auxiliary Light Kit Box.

LIFT SYSTEM AND LIGHT BRACKET INSTALLATION
PARTS LIST

REF. NO.	DESCRIPTION	PART NO.	QTY.
A	Auxiliary Light Brackets	LTX0009	1 Set
B	Lift Arm	LFA1400	1
C	Auxiliary Headlights	MSC1513	2
D	Hydraulic Lift/Angle Cylinder	HYD1603	1
E	90 Degree Swivel (3/8" to 1/4")	HYD1619	1
F	5/8 x 4-1/2 Hex Head Bolt	HDW1705	1
G	5/8 x 4 Hex Head Bolt	HDW1706	1
H	5/8 x 3-1/2 Hex Head Bolt	HDW1707	1
I	5/8 Self Locking Nut	HDW1709	3
J	3/8 x 1 Hex Head Bolt	HDW1717	4
K	3/8 x 1-1/2 Hex Head Bolt	HDW1719	4
L	3/8 Self Locking Nut	HDW1720	8
M	Lift Tower Assembly	LTA2500	1

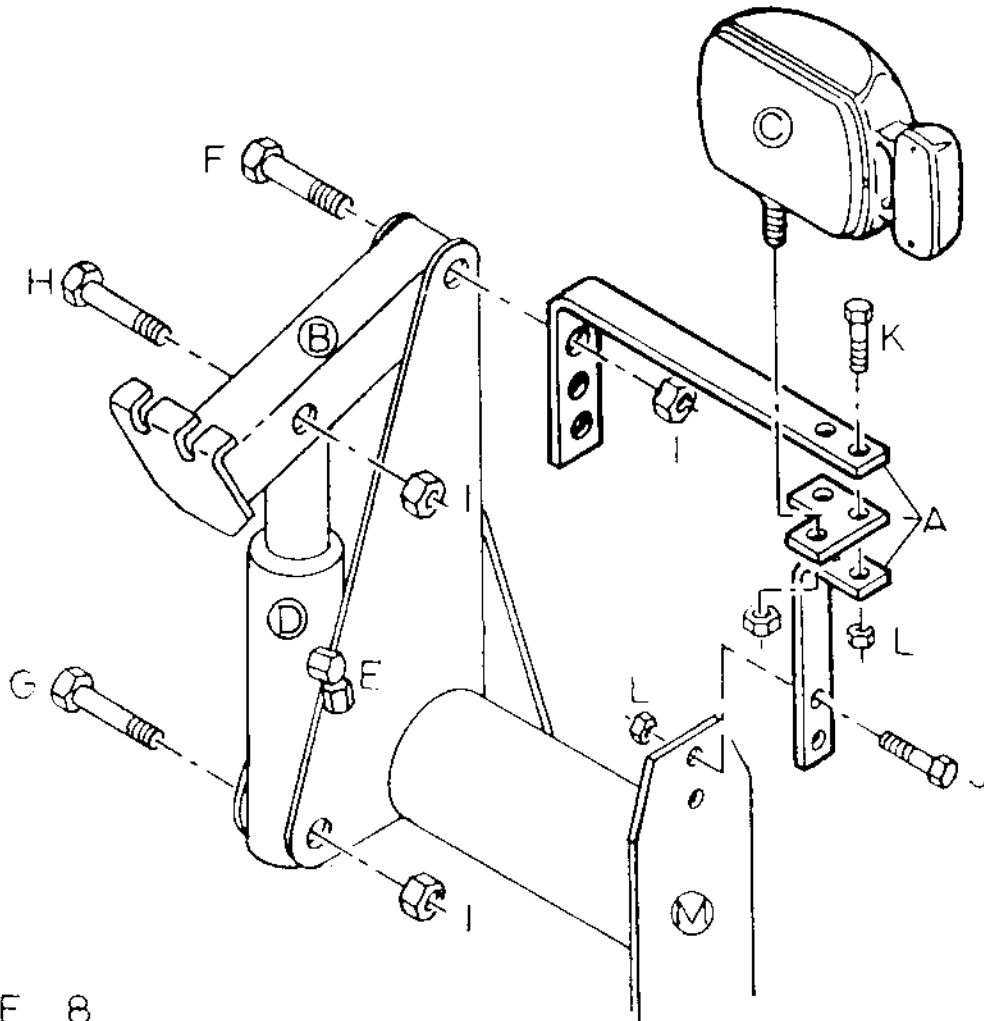
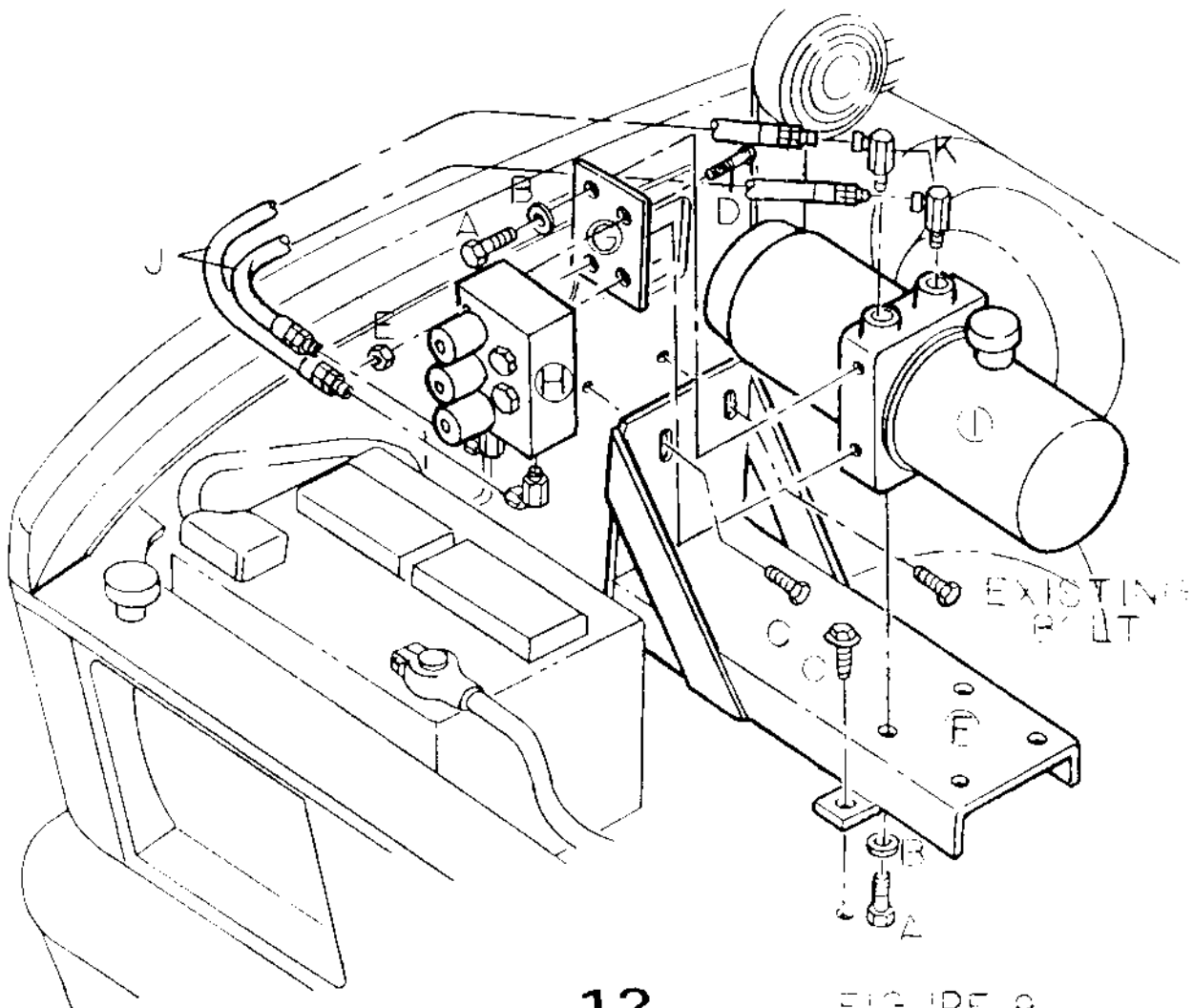

FIGURE 8

FORD (DIESEL)
PUMP BRACKET INSTALLATION

REF. NO.	DESCRIPTION	PART NO.	QTY.
A	3/8 x 3/4 Hex Head Bolt	HDW1743	4
B	3/8 Lock Washer	HDW1718	4
C	5/16 x 1 Sheet Metal Screw	HDW1730	2
D	1/4 x 2 1/2 Hex Head Bolt (V-Plow)	HDW1724	2
E	1/4 Self Locking Nut (V-Plow)	HDW1725	2
F	Pump Bracket	LTA2517	1
G	Valve Mounting Plate	LTA2526	1
H	Hydraulic Valve Assembly (V-Plow)	HYD1602	1
I	Hydraulic Pump (V-Plow)	HYD1600	1
	(Straight Blade)	STB3006	1
J	Hydraulic Hose 1/4" x 18" (V-Plow)	HYD1660	2
K	90 Degree Swivel ("O" Ring)	HYD1620	2



ALTERNATE METHOD OF ATTACHING
THE RAPID-TACH RELEASE CABLE

REF. NO.	DESCRIPTION	PART NO.	QTY.
A	Rapid-Tach Release Cable	MSC1512	1
B	Cable Clamp	HDW1701	1
C	1/4" x 1" Hex Head Bolt	HDW1723	1
D	1/4" Self Locking Nut	HDW1725	1
E	Auxiliary Light Bracket	LTX0009	1
F	Lift Tower	LTA2500	1

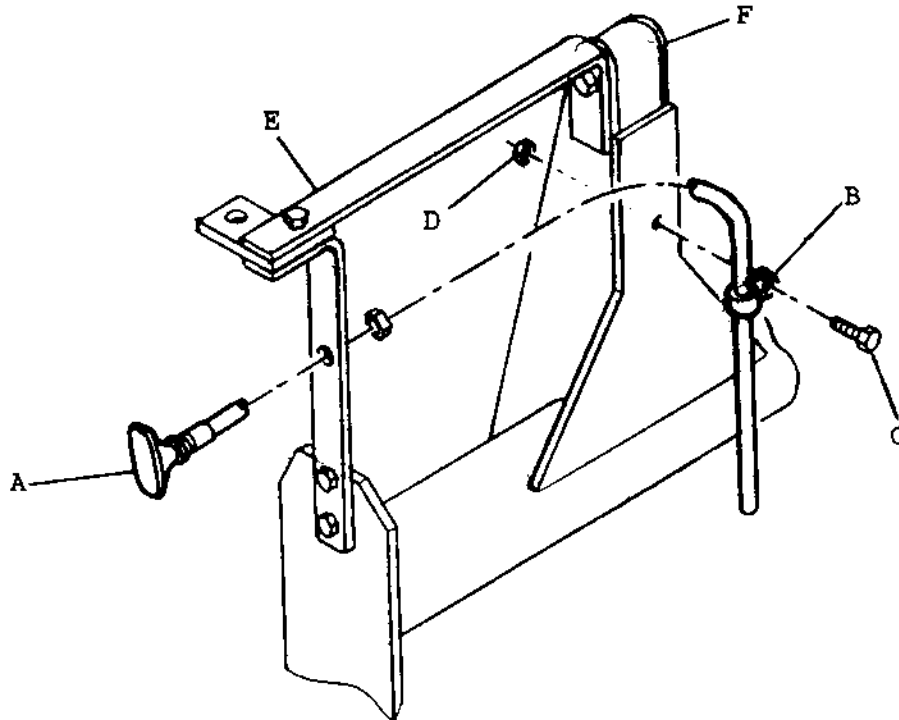

Figure 10