



**1990 & OLDER DODGE
PART NO.'S
LTA2605 ALL W150/W250/W350 SERIES
(EXCEPT 89 & 90 W150)
LTA2615 1989 & 1990 W150 SERIES
UNDERCARRIAGE MOUNTING INSTRUCTIONS**

TABLE OF CONTENTS

UNDERCARRIAGE MOUNTING INSTRUCTIONS 2
PUSH BEAM ASSEMBLY PARTS LIST (FIGURE 1)..... 3
UNDERCARRIAGE PARTS LIST (FIGURE 3)..... 5
TORQUE CHART (FIGURE 4).....6
LIFT SYSTEM AND HEADLIGHT INSTALLATION INSTRUCTIONS 9
LIFT SYSTEM AND LIGHT BRACKET INSTALLATION PARTS LIST..... 10
PUMP BRACKET INSTALLATION11
ALTERNATE METHOD OF ATTACHING THE RAPID-TACH RELEASE CABLE.....13
TWO YEAR WARRANTY14

**1990 & OLDER DODGE
PART NO.'S
LTA2605 ALL W150/W250/W350 SERIES
(EXCEPT 1989 & 90 W150)
LTA2615 1989 & 1990 W150
UNDERCARRIAGE MOUNTING INSTRUCTIONS**

The mounting procedure outlined below covers DODGE 1/2, 3/4, and 1 ton trucks. You will need to refer to the illustration that corresponds to your vehicle and familiarize yourself with each of the undercarriage components and their relative position to each other. Then proceed as follows:

1. Remove the truck bumper and bumper brackets.
2. Position the LIFT TOWER ASSEMBLY (Ref. No. 74, Fig. 3) to the front frame rails of the truck. Using the hex head bolts, flat washers, and self locking nuts provided bolt the LIFT TOWER ASSEMBLY to the front of the frame rails. See Figure 7. Fasteners should only be finger tight.
3. Assemble the PUSH BEAM ASSEMBLY (Ref. No. 62, Fig. 1) as shown.
4. Attach the PUSH BEAM ASSEMBLY to the LIFT TOWER ASSEMBLY as shown in Figure 3 using hex head bolts and self locking nuts indicated. Fasteners should only be finger tight. To determine the mounting height of the PUSH BEAM ASSEMBLY see plow type below:

A) V-Plow Measure from the center of the HORIZONTAL MOUNTING PIN (see Figure 2) on the T-FRAME to the ground when the plow is in the vee position. Position the PUSH BEAM ASSEMBLY to the appropriate height so the MOUNTING JAWS (see Figure 2) will accept the HORIZONTAL MOUNTING PIN on the T-FRAME.

NOTE: Should the PUSH BEAM ASSEMBLY be mounted higher than the HORIZONTAL MOUNTING PINS, the nose of the plow will tend to dig in while plowing. If the PUSH BEAM ASSEMBLY is mounted too low, the wings of the plow will not lay flat against the ground. This will be most apparent when plowing in the carry position.

B) Straight Blade Plow The distance from the ground to the top of the lower mounting jaw should be approximately 11-1/2" (See Figure 2).

5. Install RIGHT ANGLE BRACKET (Ref. No. 75R, Fig. 3) and LEFT ANGLE BRACKET (Ref. No. 75L, Fig. 3) from the mounting points on the LIFT TOWER ASSEMBLY to their respective positions on the truck frame using hex head bolts, flat washers, and self locking nuts provided. See Figure 5. Fasteners should only be finger tight.

6. With all undercarriage parts in place, securely fasten all mounting hardware. IT IS IMPORTANT THAT FASTENERS BE PROPERLY TORQUED (SEE FIGURE 4) TO ASSURE A SAFE OPERATING PLOW.

7. Reinstall the front bumper directly to the LIFT TOWER ASSEMBLY using the vehicle existing bumper mounting bolts and nuts.

With the above items completed, the hydraulic system can be installed. Refer to the Hydraulic Section for step by step instructions on how to install the HYDRAULIC PUMP, VALVE ASSEMBLY, HOSES, and CONTROL SWITCHES.

PUSH BEAM ASSEMBLY PARTS LIST (FIGURE 1)

REF. NO.	DESCRIPTION	PART NO.	QTY.
36	Rapid-Tach Release Cable	MSC1512	1
48 - 49	Cable Stop	HDW1745	1
62	Push Beam Assembly	PBA2200	1
63	Push Beam Release Strap	PBX0010	1
64	Rapid-Tach Pin	HDW1710	2
65	Rapid-Tach Spring		2
66	Cotter Pin		2
66	5/8" Flat Washer		4

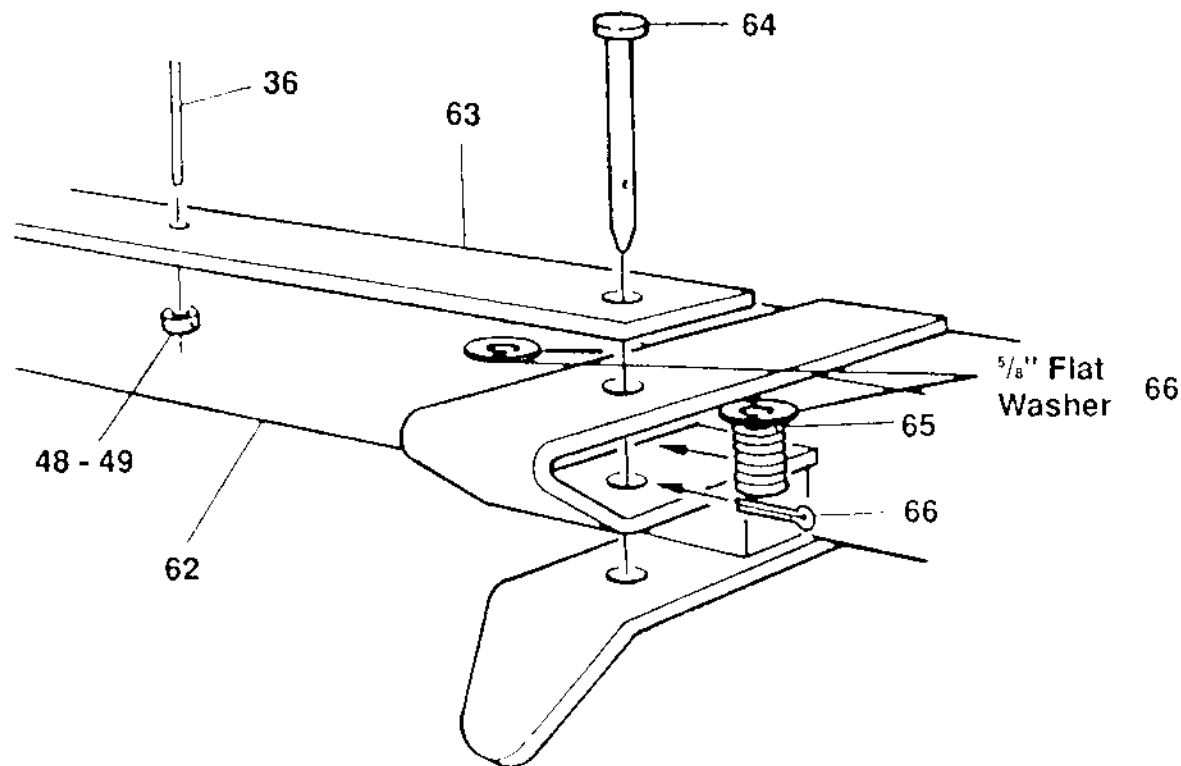

Figure 1

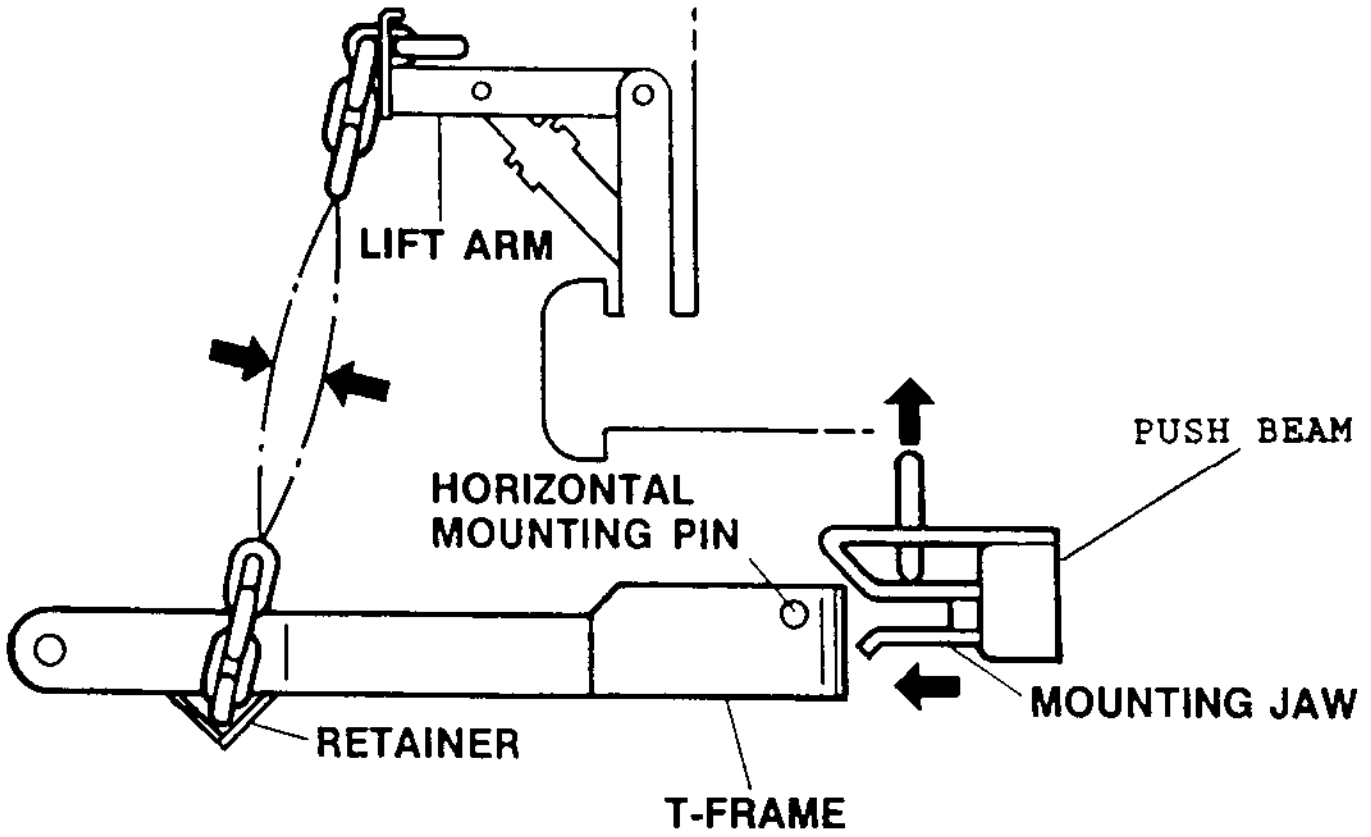

Figure 2

**1990 & OLDER DODGE
PART NO.'s LTA2605 & 2615
UNDERCARRIAGE PARTS LIST**

REF. NO.	DESCRIPTION	PART NO.	QTY.
74	Lift Tower Assembly	LTA2600	1
62	Push Beam Assembly	PBA2200	1
75R	Right Angle Bracket	LTA2601	1
75L	Left Angle Bracket (LTA2605)	LTA2602	1
75L	Left Angle Bracket (LTA2615)	LTA2607	1
A	5/8 x 4-1/2 Hex Head Bolt		1
B	5/8 x 4 Hex Head Bolt		1
C	5/8 x 1-1/2 Hex Head Bolt		14
D	1/2 x 1-1/2 Hex Head Bolt		8
E	5/8 Self Locking Nut		16
F	1/2 Self Locking Nut		8
G	1/2 Flat Washer		16
H	5/8 Flat Washer		4

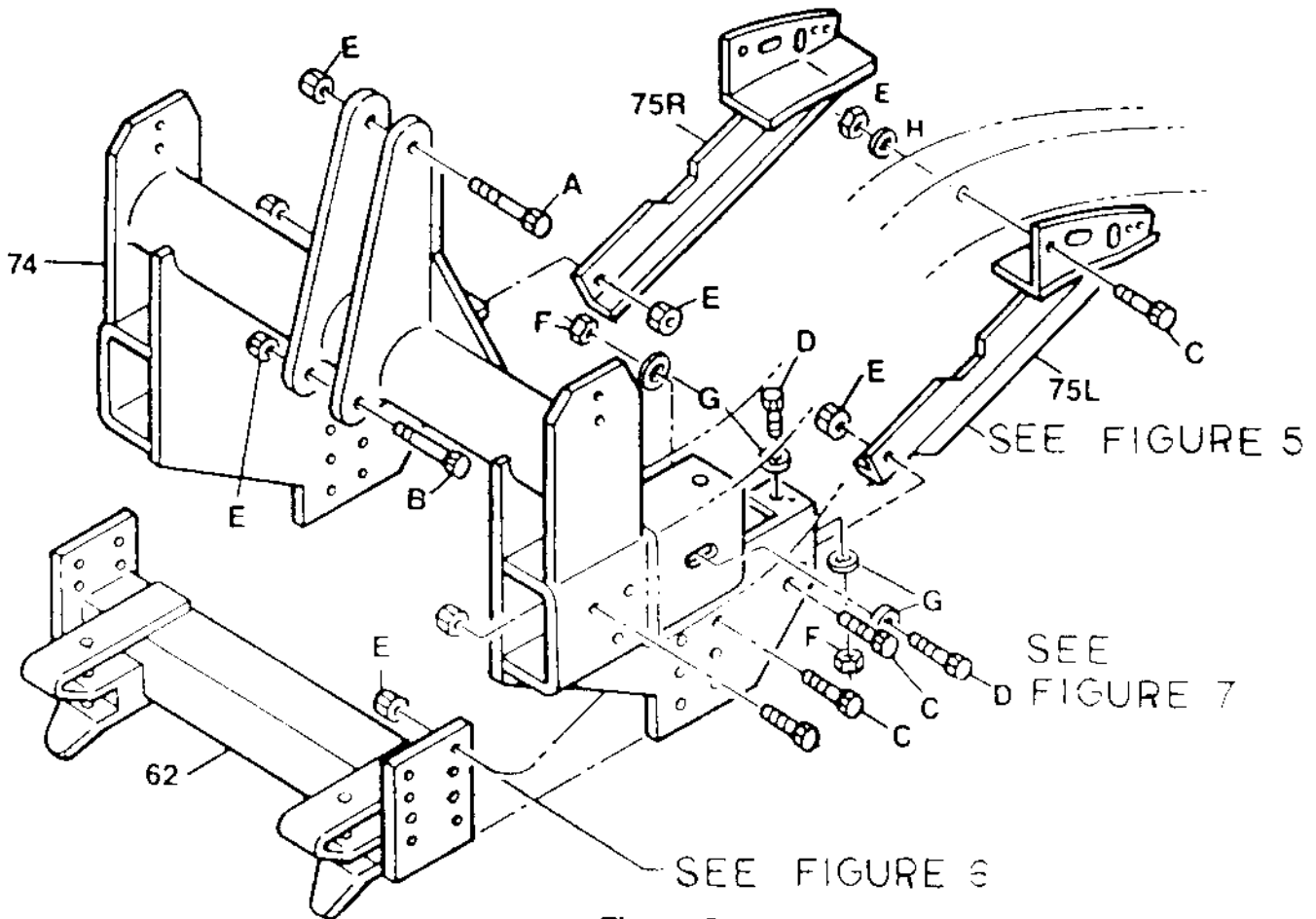
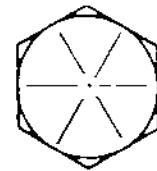

Figure 3

GUIDE TO RECOMMENDED ASSEMBLY TORQUE

All Torque Values Are In Foot-Pounds (Ft.-Lb.)



DIA./PITCH	GRADE 5	GRADE 8
1/4 - 20	6	9
5/16 - 18	14	19
3/8 - 16	23	33
7/16 - 14	38	53
1/2 - 13	56	80
9/16 - 12	82	116
5/8 - 11	113	159
3/4 - 10	201	283

* The torque values listed above are based on dry, coated bolts, variables such as oil, or other lubrications may appreciably alter these values and must be taken into consideration.

NOTE: IT IS IMPORTANT THAT ALL FASTENERS BE PROPERLY TORQUED TO ASSURE A SAFE OPERATING PLOW.

Figure 4

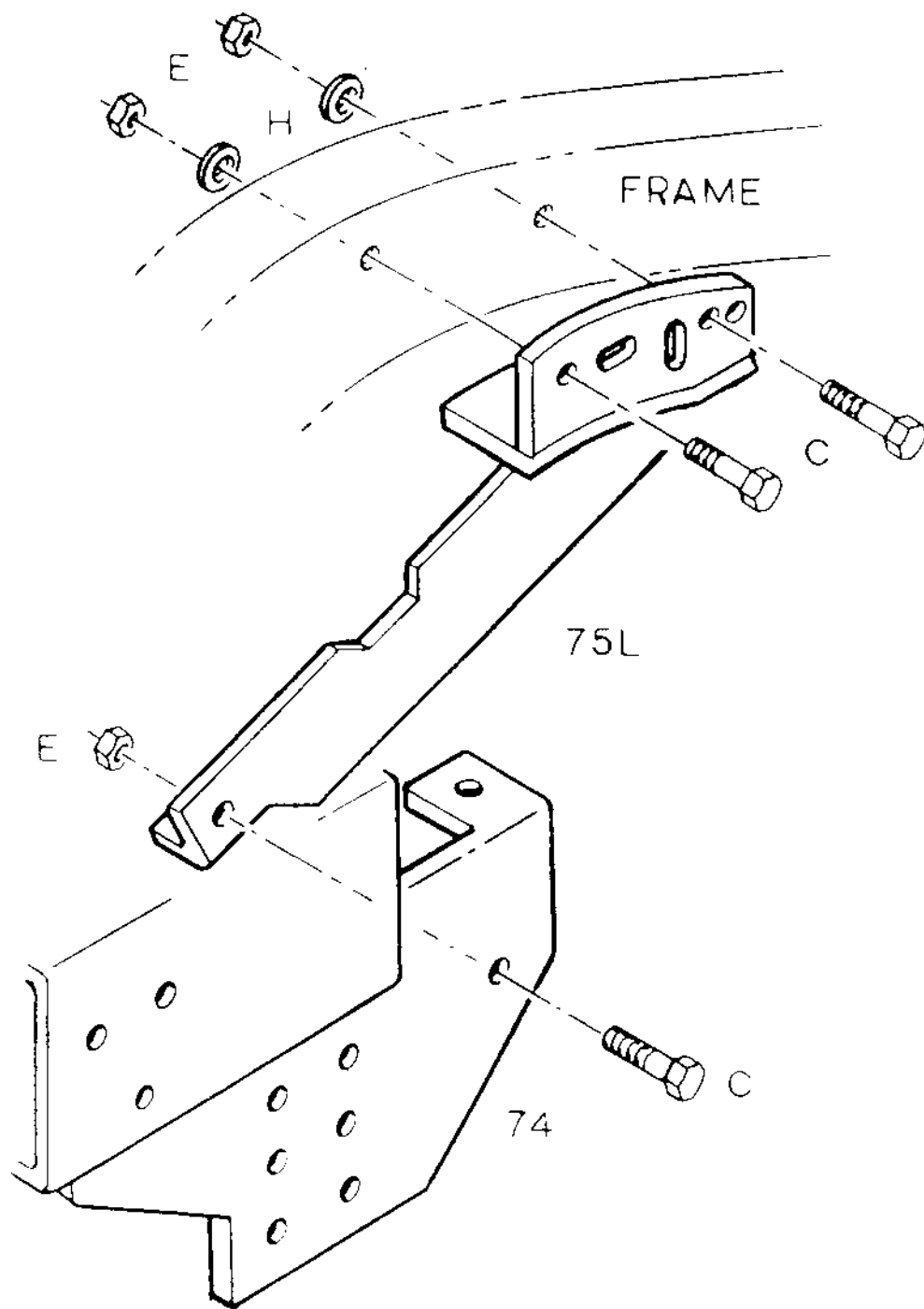

Figure 5

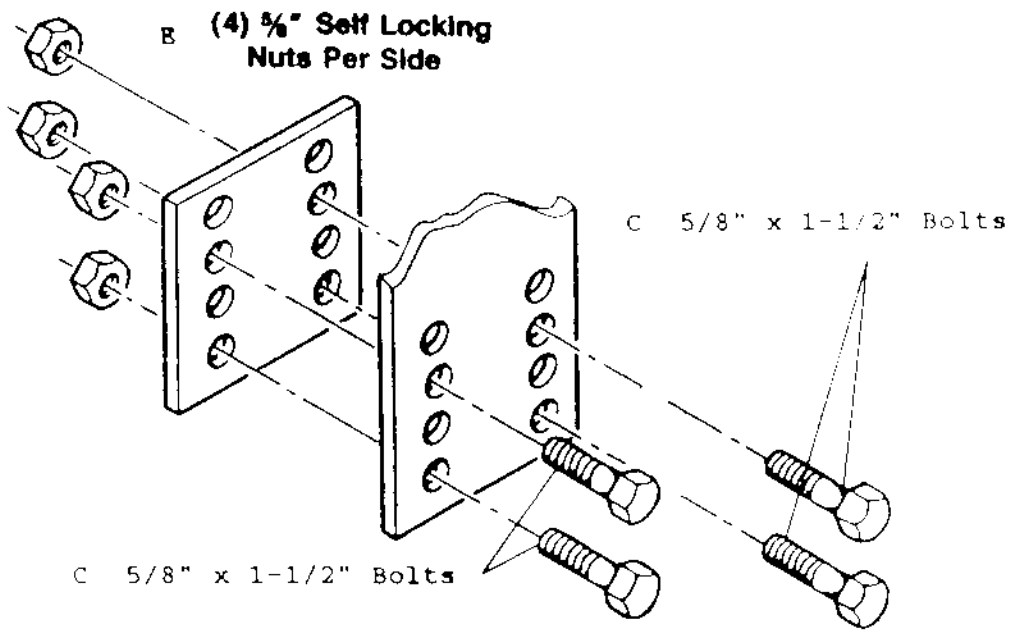

Figure 6

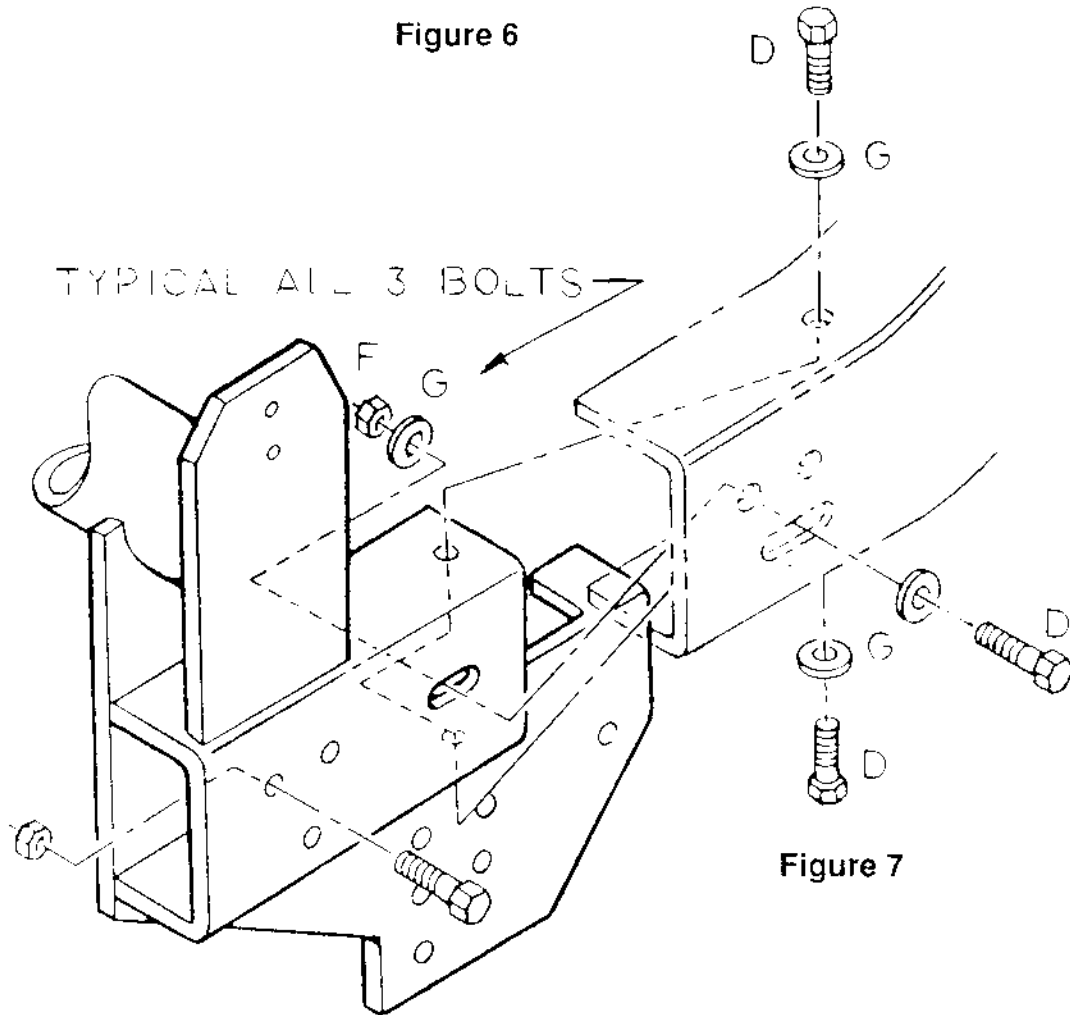

Figure 7

LIFT SYSTEM AND HEADLIGHT INSTALLATION INSTRUCTIONS

1. Install the AUXILIARY LIGHT BRACKETS (Ref. No. 8, Fig. 8) to the LIFT TOWER as shown in Figure 8 using the hex head bolts and nuts provided.
2. Install LIFT ARM (Ref. No. 7, Fig. 8) to the top of the LIFT TOWER ASSEMBLY using the 5/8" x 4-1/2" HEX HEAD BOLT (Ref. No. F, Fig. 8) and 5/8" SELF LOCKING NUT (Ref. No. I, Fig. 8) provided.
3. Position the LIFT CYLINDER (Ref. No. 17, Fig. 8) in its respective position on the LIFT TOWER and fasten by using the 5/8" x 4" HEX HEAD BOLT (Ref. No. G, Fig. 8) and 5/8" SELF LOCKING NUT (Ref. No. I, Fig. 8) provided. Install the 90 DEGREE SWIVEL FITTING (Ref. No. 31, Fig. 8). Fasten the rod end of the cylinder to the LIFT ARM using the 5/8" x 3-1/2" HEX HEAD BOLT (Ref. No. H, Fig. 8) and 5/8" SELF LOCKING NUT (Ref. No. I, Fig. 8) provided.
4. Mount the AUXILIARY HEADLIGHTS (Ref. No. 38, Fig. 8) to the AUXILIARY LIGHT BRACKETS as shown in Figure 8. Do not tighten the AUXILIARY HEADLIGHT mounting nut as the positioning of the lights will have to be adjusted once the wiring has been completed.
5. A diagram has been provided in each Light Kit Box to illustrate the proper method of wiring the AUXILIARY HEADLIGHTS to the existing vehicle wiring harness.
6. Be sure to route all wires away from all sharp obstructions and securely position them away from hot or moving parts.
7. Your AUXILIARY HEADLIGHT KIT comes with all of the necessary wiring, connectors and switch.
8. When the wiring of the AUXILIARY HEADLIGHTS has been completed, follow the Head Lamp Aiming instructions also provided in the Auxiliary Light Kit Box.

LIFT SYSTEM AND LIGHT BRACKET INSTALLATION PARTS LIST

REF. NO.	DESCRIPTION	PART NO.	QTY.
7	Lift Arm	LFA1400	1
8	Auxiliary Light Brackets	LXT0009	1 Set
17	Hydraulic Lift/Angle Cylinder	HYD1603	1
31	90 Degree Swivel (3/8" to 1/4")	HYD1619	1
38	Auxiliary Headlights	MSC1513	2
74	Lift Tower Assembly	LTA2600	1
F	5/8 x 4-1/2 Hex Head Bolt		1
G	5/8 x 4 Hex Head Bolt		1
H	5/8 x 3-1/2 Hex Head Bolt		1
I	5/8 Self Locking Nut		3
J	3/8 x 1 Hex Head Bolt		4
K	3/8 X 1-1/2 Hex Head Bolt		4
L	3/8 Self Locking Nut		8

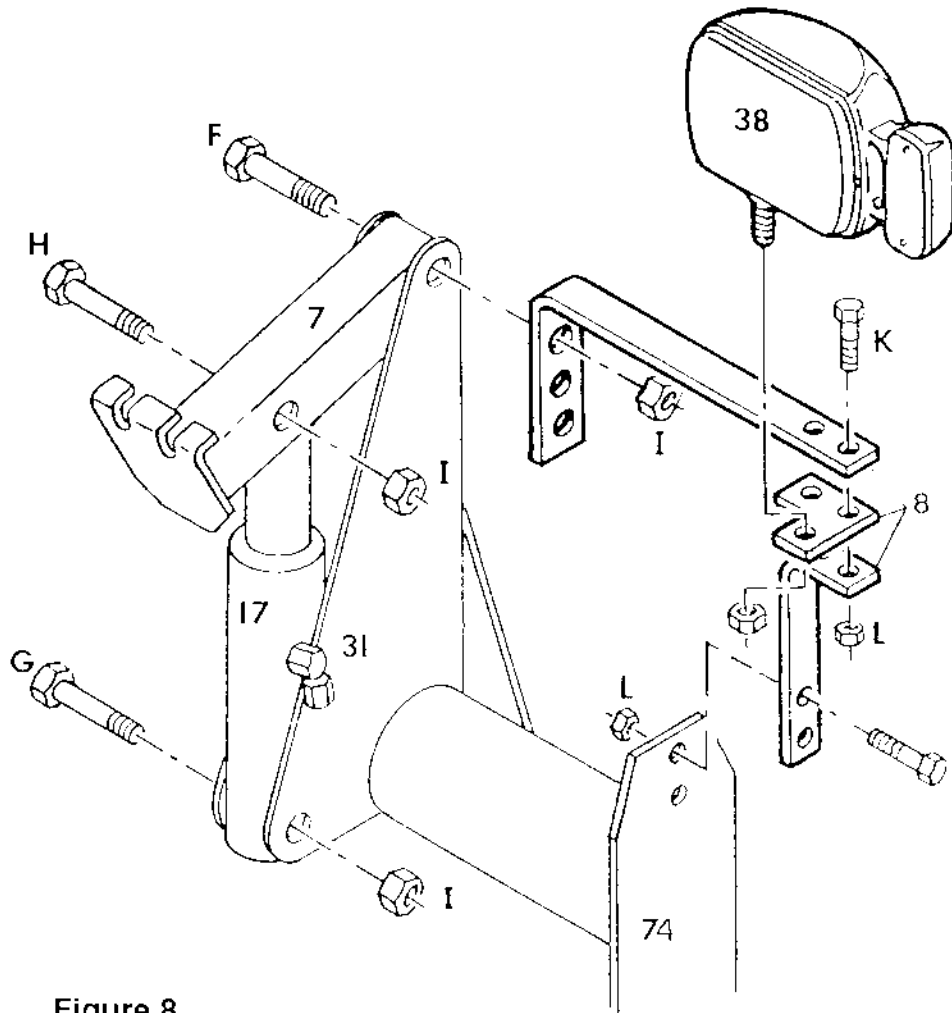

Figure 8

DODGE PUMP BRACKET INSTALLATION

REF. NO.	DESCRIPTION	PART NO.	QTY.
14	Hydraulic Pump (V-Plow) (Straight Blade)	HYD1600 STB3006	1
15	Hydraulic Valve Assembly (V-Plow)	HYD1602	1
32	90 Degree Swivel ("O" Ring)	HYD1620	2
75R	Dodge Angle Bracket (Right)	LTA2601 or LTA2620	1
86	Pump Bracket Includes: Valve Body Mounting Bracket	LTX0076 LTX0077	1
A	1/4 Self Locking Nut (V-Plow) (Straight Blade)		2 4
B	3/8 x 3/4 Hex Head Bolt		4
C	3/8 Lock Washer		4
D	1/4 x 2-1/2 Hex Head Bolt (V-Plow)		2
E	5/8 x 2 Hex Head Bolt		2
F	5/8 Self Locking Nut		2

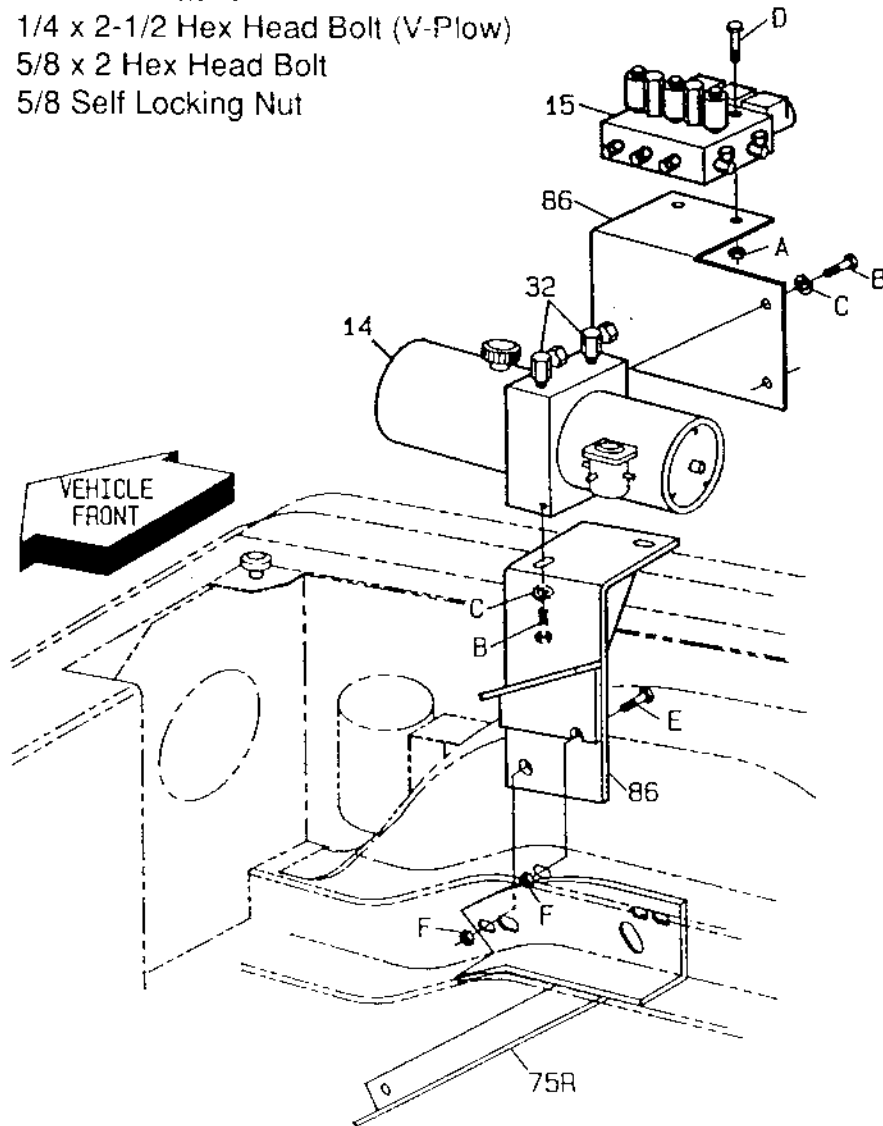

Figure 9

DODGE DIESEL PUMP BRACKET INSTALLATION

REF. NO.	DESCRIPTION	PART NO.	QTY.
14	Hydraulic Pump (V-Plow)	HYD1600	1
15	Hydraulic Valve Assembly (V-Plow)	HYD1602	1
86	Pump Bracket	LTA2629	1
	Includes:		
	1 - Valve Block Mtg. Plate		
	1 - Fender Brace		
	2 - Fender Backing Plates		
A	Existing Vehicle Bolt		1
B	1/4 x 1 Hex Head Bolt		4
C	3/8 x 3/4 Hex Head Bolt		4
D	3/8 Lock Washer		4
E	1/4 x 2-1/2 Hex Head Bolt		2
F	1/4 Flat Washer		4
G	1/4 Lock Nut		6

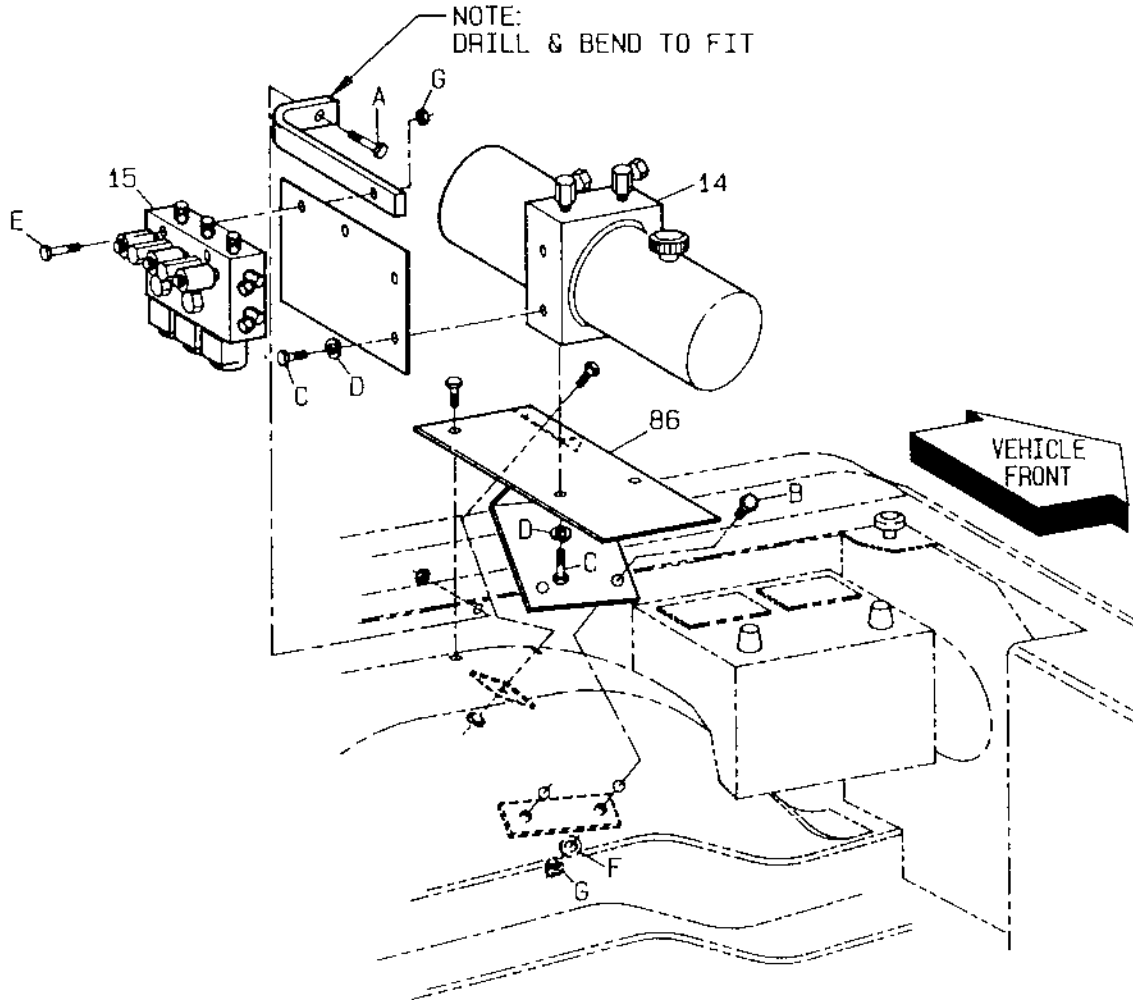

Figure 9A

ALTERNATE METHOD OF ATTACHING THE RAPID-TACH RELEASE CABLE

REF. NO.	DESCRIPTION	PART NO.	QTY.
8	Auxiliary Light Bracket	LTX0009	1
36	Rapid-Tach Release Cable	MSC1512	1
48 - 49	Cable Clamp	HDW1701	1
74	Lift Tower		1
C	1/4" x 1" Hex Head Bolt	HDW1723	1
D	1/4" Self Locking Nut	HDW1725	1

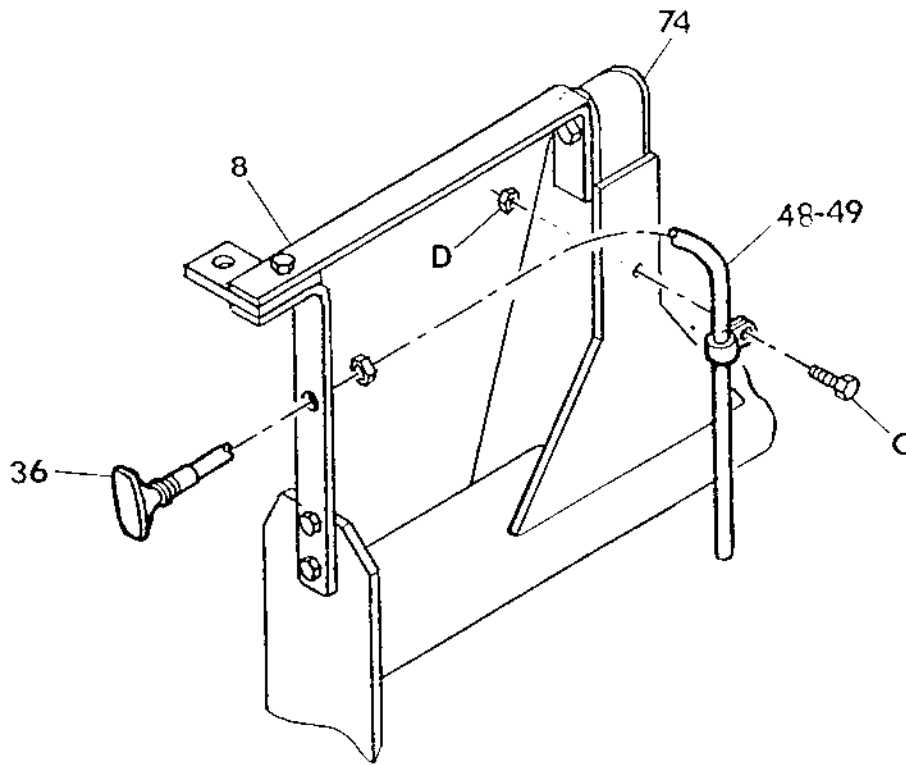

Figure 10