

# **BLIZZARD<sup>®</sup>**

## **SNOWPLOWS**



### **Model 810, 8611LP & 8611 POWER PLOW™ Snowplows**

### **Installation Instructions & Owner's Manual**

**⚠ CAUTION**

See your BLIZZARD<sup>®</sup> sales outlet/Web site for specific vehicle application recommendations before installation. The Undercarriage Selection Guide has specific vehicle and snowplow requirements.

**⚠ CAUTION**

Read this document before installing the snowplow.

**⚠ CAUTION**

Read this document before operating or servicing snowplow.

This manual supersedes all editions with an earlier date.

---

Congratulations on purchasing the most advanced snowplow available! The POWER PLOW™ snowplow is clearing new trails for innovative design, rugged durability, quality craftsmanship and superior performance. Our innovative products are tested all over the snowbelt.

This manual provides safety, operation and maintenance information for your new BLIZZARD® snowplow. To keep your snowplow in good condition, read and understand this manual and follow its recommendations. Failure to do so may affect your warranty coverage.

When service is necessary, your local BLIZZARD distributor knows your snowplow best. Contact your BLIZZARD outlet for maintenance, service or any other assistance you may require.

If you have not already done so, please visit [www.blizzardplows.com](http://www.blizzardplows.com) to register your new POWER PLOW snowplow.



# TABLE OF CONTENTS

---

<b>SAFETY INFORMATION</b> .....	4	<b>POWER HITCH™ SYSTEM INSTRUCTIONS</b> .....	30
<b>VEHICLE APPLICATION INFORMATION</b> .....	7	<b>TESTING YOUR SNOWPLOW</b> .....	31
Vehicle Application Recommendations .....	7	<b>HEADLAMP AIMING</b> .....	33
Ballast Requirements.....	7	<b>MAINTENANCE</b> .....	34
<b>OPERATION</b> .....	8	Maintenance Table.....	34
<b>UNPACKING &amp; INSPECTION</b> .....	9	Removing Snowplow from Storage .....	34
<b>TORQUE SPECIFICATIONS</b> .....	10	Lifting .....	34
<b>MOLDBOARD &amp; A-FRAME ASSEMBLY</b> .....	12	<b>TECHNICAL SPECIFICATIONS</b> .....	35
<b>ELECTRICAL &amp; HYDRAULIC SYSTEMS</b> .....	18	<b>TROUBLESHOOTING</b> .....	36
General System Schematics .....	18	<b>PARTS LISTS</b> .....	38
Hydraulic Valve & Hose Port Guide .....	19	Moldboard & Wing Parts—810 & 8611 Models... 38	
Harness Plugs .....	20	Moldboard & Wing Parts—8611LP Model..... 41	
Electrical Installation—Snowplow Side .....	21	A-Frame & Pivot Beam Parts—All Models..... 43	
Electrical Schematics—Snowplow Side .....	22	Power Unit Parts—All Models .....	46
Electrical Installation—Vehicle Side .....	24	Headlamps & Control Parts—All Models .....	48
Electrical Schematics—Vehicle Side .....	26	Accessories and Kits—All Models .....	50

# SAFETY

## SAFETY DEFINITIONS

### ⚠ WARNING

Indicates a potentially hazardous situation that, if not avoided, could result in death or serious personal injury.

### ⚠ CAUTION

Indicates a potentially hazardous situation that, if not avoided, may result in minor or moderate injury. It may also be used to alert against unsafe practices.

**NOTE:** Indicates a situation or action that can lead to damage to your snowplow and vehicle or other property. Other useful information can also be described.

## WARNING/CAUTION AND INSTRUCTION LABELS

Become familiar with and inform users about the warning and instruction labels on the back of the blade.

**NOTE:** If labels are missing or cannot be read, see your sales outlet.

MOUNT INSTRUCTIONS		DISMOUNT INSTRUCTIONS	
Read Owner's Manual for Complete Instructions.		Read Owner's Manual for Complete Instructions.	
<p><b>STEP #1</b></p> <p>CONNECT/DISCONNECT POWER HITCH Switch</p> <p>Pushbeam Receiver Mount Pin</p> <p>Kickstand Pin</p> <p>Adjustable Kickstand</p> <p>POWER HITCH Arm</p> <p>Slowly Move Vehicle Forward</p> <p><b>WARNING:</b> Keep fingers away. POWER HITCH arm raises behind undercarriage pushbeam.</p> <ul style="list-style-type: none"> <li>Kickstand must be lowered, with kickstand pin seated in lower hole on pivot beam.</li> <li>Slowly drive vehicle forward until pushbeam receiver mount points contact A-frame mount bushings.</li> <li>Turn POWER HITCH OPERATION switch (on plow control) to "ON" position.</li> <li>Connect plow and vehicle electrical harnesses. Connect weather caps together.</li> </ul>	<p><b>STEP #1</b></p> <p>CONNECT/DISCONNECT POWER HITCH Switch</p> <p>Adjustable Kickstand</p> <p>POWER HITCH Arm</p> <p>Slowly Move Vehicle Backward</p> <p><b>WARNING:</b> Keep fingers away from plow and truck mounting points.</p> <ul style="list-style-type: none"> <li>Raise plow. Lower kickstand until kickstand pin is seated in lower hole on pivot beam.</li> <li>Lower plow on flat, level surface. Turn vehicle ignition off.</li> <li>Remove hitch pins from A-frame and undercarriage.</li> <li>Turn vehicle ignition on.</li> <li>Turn POWER HITCH OPERATION switch (on plow control) to "OFF" position.</li> </ul>		
<p><b>STEP #2</b></p> <p>A-Frame Latch</p> <p>POWER HITCH Arm</p> <p>Pushbeam Receiver Mount Pin</p> <p>Slowly Move Vehicle Forward</p> <p><b>WARNING:</b> Keep fingers away from plow and truck mounting points.</p> <ul style="list-style-type: none"> <li>Pull A-frame latch lock pin out and lower A-frame latch over draw pin.</li> <li>Push and hold CONNECT/DISCONNECT switch upward. POWER HITCH arm will engage back of pushbeam and pull plow into pushbeam receiver mount points on vehicle.</li> <li>Insert both hitch pins and secure each with hair pin cotter.</li> <li>Lower POWER HITCH arm to relieve tension on A-frame latch. Raise A-frame latch and lock into position with lock pin. Raise plow.</li> <li>Raise kickstand until kickstand pin seats into upper hole on pivot beam.</li> </ul>	<p><b>STEP #2</b></p> <p>CONNECT/DISCONNECT POWER HITCH Switch</p> <p>Adjustable Kickstand</p> <p>POWER HITCH Arm</p> <p>Slowly Move Vehicle Backward</p> <p><b>WARNING:</b> Keep fingers away from plow and truck mounting points.</p> <ul style="list-style-type: none"> <li>Push and hold CONNECT/DISCONNECT switch downward. POWER HITCH arm will disengage from behind undercarriage pushbeam and lower.</li> <li>Disconnect plow and vehicle electrical harnesses. Install weather caps.</li> <li>Turn SYSTEM POWER (on plow control) to "OFF" position.</li> <li>Slowly move vehicle backward away from plow.</li> </ul>		

<h3>⚠ WARNING</h3> <p>Lower blade when vehicle is parked.</p> <p>Do not exceed GVWR or GAWR including blade and ballast.</p>	
<h3>⚠ CAUTION</h3> <p>Read Owner's Manual before operating or servicing snowplow.</p> <p>Transport speed should not exceed 45 mph (72 km/h). Further reduce speed under adverse travel conditions.</p> <p>Plowing speed should not exceed 10 mph (16 km/h).</p> <p>See your sales outlet/Web site for specific vehicle application recommendations.</p> <p>59900</p>	

<h3>⚠ WARNING</h3> <p>Multiple Pinch Points</p>
---

**POWER FLOW™ & SPEEDWING™ Blades Only (both sides)**

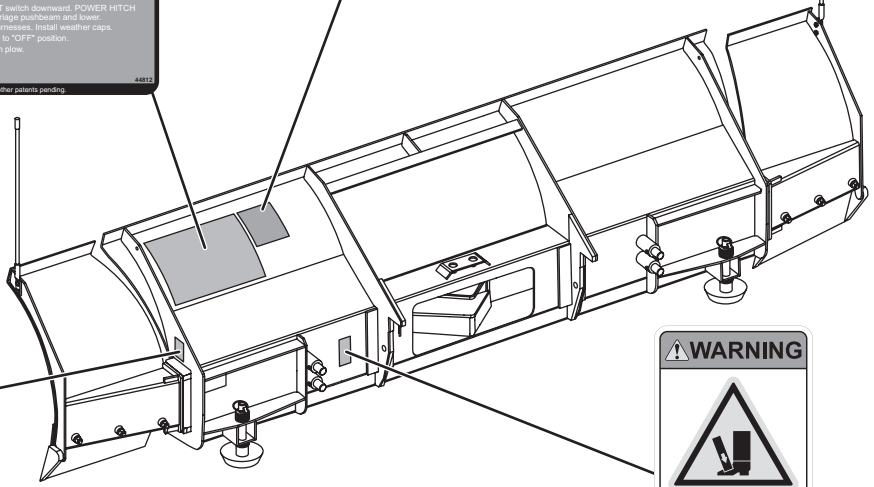

<h3>⚠ WARNING</h3> <p>Crush hazard</p> <p>Keep feet clear</p> <p>29296</p>
--

# SAFETY

## SAFETY PRECAUTIONS

Improper installation and operation could cause personal injury and/or equipment and property damage. Read and understand labels and the Owner's Manual before installing, operating or making adjustments.

### ⚠ WARNING

Lower the blade when the vehicle is parked. Temperature changes could change hydraulic pressure, causing the blade to drop unexpectedly or damaging hydraulic components. Failure to do this could result in serious personal injury.

### ⚠ WARNING

You can die or be seriously injured. Keep hands and feet away from hitch mechanism and snowplow blade when operating the POWER HITCH™ arm. The action of the arm moves the snowplow toward the vehicle and into position for proper attachment.

### ⚠ WARNING

The driver shall keep bystanders clear of the blade when it is being raised, lowered or angled. Do not stand between vehicle and blade or within 8 feet of a moving blade. A moving or falling blade could cause personal injury.

### ⚠ WARNING



Do not exceed GVWR or GAWR including the blade and ballast. The rating label is found on the driver-side vehicle door cornerpost.

### ⚠ WARNING

To prevent accidental movement of the blade, always turn the control OFF whenever the snowplow is not in use. The power indicator light will turn OFF.

### ⚠ WARNING

Remove blade assembly before placing vehicle on hoist.

### ⚠ CAUTION

Read Owner's Manual before operating or servicing snowplow.

### ⚠ CAUTION

Transport speed should not exceed 45 mph (72 km/h). Further reduce speed under adverse travel conditions.

### ⚠ CAUTION

Plowing speed should not exceed 10 mph (16 km/h).

### ⚠ CAUTION

See your BLIZZARD® outlet for application recommendations.

## HYDRAULIC SAFETY

### ⚠ WARNING



Hydraulic fluid under pressure can cause skin injection injury. If you are injured by hydraulic fluid, get medical attention immediately.

- Always inspect hydraulic components and hoses before using. Replace any damaged or worn parts immediately.
- If you suspect a hose leak, DO NOT use your hand to locate it. Use a piece of cardboard or wood.

## FUSES

The snowplow electrical and hydraulic systems contain several blade-style automotive fuses. If a problem should occur and fuse replacement is necessary, the replacement fuse must be of the same type and amperage rating as the original. Installing a fuse with a higher rating could damage the system and could start a fire. Fuse Replacement, including fuse ratings and locations, is located in the Maintenance section of this Owner's Manual.

# SAFETY

---

## PERSONAL SAFETY

- Remove ignition key and put the vehicle in park or in gear to prevent others from starting the vehicle during installation or service.
- Wear only snug-fitting clothing while working on your vehicle or snowplow.
- Do not wear jewelry or a necktie, and secure long hair.
- Wear safety goggles to protect your eyes from battery acid, gasoline, dirt and dust.
- Avoid touching hot surfaces such as the engine, radiator, hoses and exhaust pipes.
- Always have a fire extinguisher handy, rated BC for flammable liquids and electrical fires.

## FIRE AND EXPLOSION

### **⚠ WARNING**

**Gasoline is highly flammable and gasoline vapor is explosive. Never smoke while working on vehicle. Keep all open flames away from gasoline tank and lines. Wipe up any spilled gasoline immediately.**

Be careful when using gasoline. Do not use gasoline to clean parts. Store only in approved containers away from sources of heat or flame.

## CELL PHONES

A driver's first responsibility is the safe operation of the vehicle. The most important thing you can do to prevent a crash is to avoid distractions and pay attention to the road. Wait until it is safe to operate Mobile Communication equipment such as cell phones, text messaging devices, pagers or two-way radios.

## VENTILATION

### **⚠ WARNING**

**Vehicle exhaust contains lethal fumes. Breathing these fumes, even in low concentrations, could cause death. Never operate a vehicle in an enclosed area without venting exhaust to the outside.**

## BATTERY SAFETY

### **⚠ CAUTION**

**Batteries normally produce explosive gases, which can cause personal injury. Therefore, do not allow flames, sparks or lit tobacco to come near the battery. When charging or working near a battery, always cover your face and protect your eyes, and also provide ventilation.**

- Batteries contain sulfuric acid, which burns skin, eyes and clothing.
- Disconnect the battery before removing or replacing any electrical components.

## NOISE

Airborne noise emission during use is below 70 dB(A) for the snowplow operator.

## VIBRATION

Operating snowplow vibration does not exceed 2.5 m/s<sup>2</sup> to the hand-arm or 0.5 m/s<sup>2</sup> to the whole body.

# VEHICLE APPLICATION INFORMATION

---

## VEHICLE APPLICATION RECOMMENDATIONS

### **⚠ CAUTION**

See your BLIZZARD® outlet for specific vehicle application recommendations before installation. The Undercarriage Selection Guide has specific vehicle and snowplow requirements.

Vehicle application recommendations are based on the following:

- The vehicle with the snowplow installed must comply with applicable Federal Motor Vehicle Safety Standards (FMVSS).
- The vehicle with the snowplow installed must comply with the vehicle manufacturer's stated gross vehicle and axle weight ratings (found on the driver-side door cornerpost of the vehicle) and the front and rear weight distribution ratio. In some cases, rear ballast may be required to comply with these requirements.
- BLIZZARD Undercarriage Selection Guide is based on available vehicle capacity for snowplow equipment on a representative vehicle equipped with options commonly used for snowplowing and with 300 lb of front seat occupant weight.
- Weights of front seat occupants can be adjusted above 300 lb, but vehicle with snowplow must not exceed vehicle GVWR or GAWR.
- some cases there may be additional limitations and requirements.
- Installation, modification and addition of accessories must comply with published BLIZZARD recommendations and instructions. Available capacity decreases as the vehicle is loaded with cargo or other truck equipment or snowplow accessories are installed.
- If there is uncertainty as to whether available capacity exists, the actual vehicle as configured must be weighed.

## BALLAST REQUIREMENTS

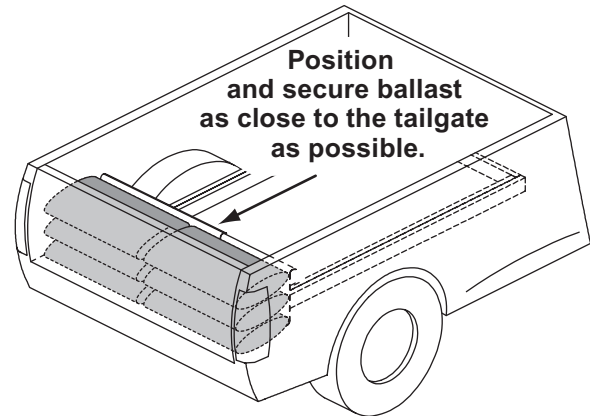

Ballast (additional weight) is an important part of qualifying vehicles for snowplow eligibility. Rear ballast must be used when necessary to remain in compliance with axle ratings and ratios as specified by the vehicle manufacturer.

If ballast is required, it is important that it be secured properly behind the rear axle. A ballast retainer kit is available from your BLIZZARD outlet, PN 62849.

---

**NOTE: The ballast retainer kit is for snowplow vehicles requiring ballast. See your BLIZZARD outlet for the correct amount of ballast required. Include the weight of the retainer as part of the ballast requirement. Sand bags are recommended for use as ballast.**

---

---

**NOTE: Ballast recommended and its weight calculations assume the entire width of the bed is filled as close to tailgate as possible.**

---

# OPERATION

Your POWER PLOW™ snowplow is the most advanced and versatile snowplow on the market. The easy-to-use controls allow you to automatically adjust the snowplow blade and wings into an infinite number of plowing positions. Review the illustrations below to determine the best position for your plowing needs.

A.

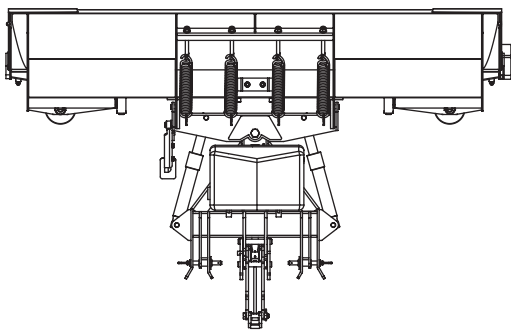

B.

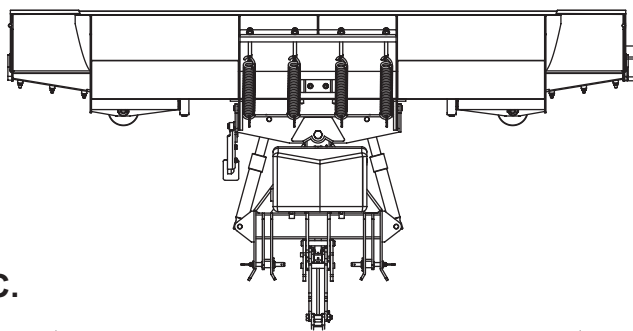

C.

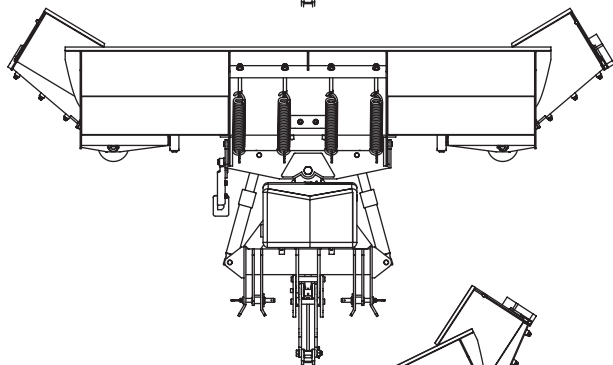

D.

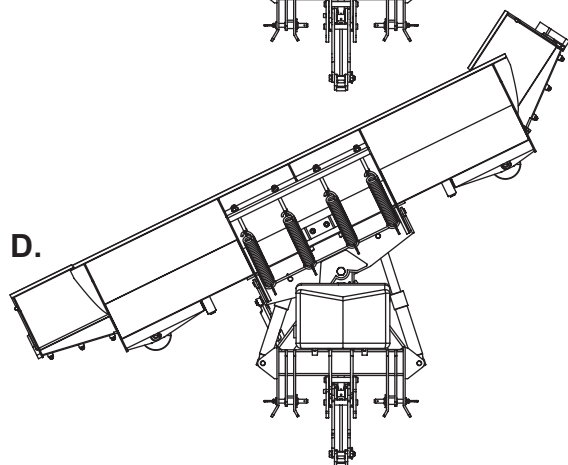

## A. Compact Position

(8' or 8'-6" Blade Width)

- Primary position when transporting the snowplow
- For use in heavy snow conditions with poor visibility, initial clearing and tight quarters
- *Ideal application: residential driveways, small roads*

## B. WIDE PASS™ Position

(10' or 11'-3" Blade Width)

- Primary position for clearing large surfaces
- For use in light snow conditions with good visibility, final clearing and clean-up
- *Ideal application: large parking lots, widening roadways*

## C. BUCKET BLADE™ Position

(9'-3" or 9'-10" Blade Width)

- Primary position for transporting snow
- For use in initial clearing with decent visibility, transporting large volumes of snow, final clean-up
- *Ideal application: roadway intersections*

## D. WIDE PASS Position Angled with Wing Forward

- Primary position for accelerated angled plowing
- For use in directional plowing, cornering, diverting snow away from objects or buildings
- *Ideal application: plowing adjacent to buildings, driveway/road intersections*

### ⚠ CAUTION

Always transport POWER PLOW snowplow with both wings fully retracted.

**NOTE:** To prevent premature failure of the power contactor (solenoid), return the joystick to its neutral (center) position, or release the touchpad button, immediately after the blade reaches the limit of any position. Continuing to hold the control after the blade has reached the limit of movement in any position will reduce the life of the solenoid.



## UNPACKING & INSPECTION

---

Your POWER PLOW™ snowplow has been packaged to withstand transit and weather related damage. Fully inspect all components upon receipt of your snowplow. In the event of shipping damage or missing parts, immediately contact our Customer Support Department at 1-888-680-8600.

Begin unpacking and inspection in the following order:

1. Remove the shipping document from the end panel of the pallet wrap. Retain all documentation for your records.
2. All wood framing and polyethylene material should be removed from the pallet for easy access to the snowplow.
3. Due to the odd-shaped components and size of several assembly parts, various cable ties and corrugated material are used for scratch resistance and package orientation. Please remove these items prior to assembly.
4. Place the main blade assembly on a flat, level surface.

Once you have inspected all parts and removed all packaging materials, your snowplow is ready to be fully assembled.

**Retain this information for your records.**

**Date of Purchase:** \_\_\_\_\_

**Distributor:** \_\_\_\_\_

**Distributor Phone Number:** \_\_\_\_\_

**Snowplow Serial Number:** \_\_\_\_\_

**Hydraulic Pump Serial Number:** \_\_\_\_\_

***Register your snowplow online at  
[www.blizzardplows.com](http://www.blizzardplows.com).***

# TORQUE SPECIFICATIONS

## TORQUE CHART

**⚠ CAUTION**

Read instructions before assembling. Fasteners should be finger tight until instructed to tighten according to the torque chart. Use standard methods and practices when attaching snowplow including proper personal protective safety equipment.



Grade Identification for J429–Grade 5 Bolt



Grade Identification for J429–Grade 8 Bolt

SAE J429 Grade 5 Torque Values				SAE J429 Grade 8 Torque Values			
Nominal Thread Size	Clamp Loads (lb)	Tightening Torque		Nominal Thread Size	Clamp Loads (lb)	Tightening Torque	
		"Lubricated"	"Dry"			"Lubricated"	"Dry"
1/4-20	2,000	6 ft-lb	8 ft-lb	1/4-20	2,850	9 ft-lb	12 ft-lb
5/16-18	3,350	13 ft-lb	18 ft-lb	5/16-18	4,700	18 ft-lb	25 ft-lb
3/8-16	4,950	23 ft-lb	31 ft-lb	3/8-16	6,950	32 ft-lb	44 ft-lb
7/16-14	6,800	37 ft-lb	50 ft-lb	7/16-14	9,600	53 ft-lb	70 ft-lb
1/2-13	9,050	57 ft-lb	75 ft-lb	1/2-13	12,800	80 ft-lb	107 ft-lb
9/16-12	11,600	82 ft-lb	109 ft-lb	9/16-12	16,400	115 ft-lb	154 ft-lb
5/8-11	14,500	113 ft-lb	151 ft-lb	5/8-11	20,300	159 ft-lb	211 ft-lb
3/4-10	21,300	200 ft-lb	266 ft-lb	3/4-10	30,100	282 ft-lb	376 ft-lb
7/8-9	29,435	321 ft-lb	430 ft-lb	7/8-9	41,550	454 ft-lb	606 ft-lb
1-8	38,600	482 ft-lb	640 ft-lb	1-8	54,540	680 ft-lb	900 ft-lb



8.8 Grade Identification for Metric–Grade 8.8 Bolt



10.9 Grade Identification for Metric–Grade 10.9 Bolt

Metric Class 8.8 Torque Values				Metric Class 10.9 Torque Values			
Diameter (mm)	Clamp Loads (lb)	Tightening Torque		Diameter (mm)	Clamp Loads (lb)	Tightening Torque	
		"Lubricated"	"Dry"			"Lubricated"	"Dry"
5	1,389	3 ft-lb	5 ft-lb	5	1,987	5 ft-lb	7 ft-lb
6	1,965	6 ft-lb	8 ft-lb	6	2,812	8 ft-lb	11 ft-lb
7	2,826	10 ft-lb	13 ft-lb	7	4,044	14 ft-lb	19 ft-lb
8	3,579	14 ft-lb	19 ft-lb	8	5,121	20 ft-lb	27 ft-lb
10	5,672	28 ft-lb	37 ft-lb	10	8,116	40 ft-lb	53 ft-lb
12	8,243	49 ft-lb	65 ft-lb	12	11,796	70 ft-lb	92 ft-lb
14	11,246	77 ft-lb	103 ft-lb	14	16,092	111 ft-lb	148 ft-lb
16	15,882	125 ft-lb	167 ft-lb	16	21,970	173 ft-lb	231 ft-lb
18	19,423	172 ft-lb	229 ft-lb	18	26,868	238 ft-lb	317 ft-lb
20	24,784	244 ft-lb	325 ft-lb	20	34,284	338 ft-lb	450 ft-lb

# TORQUE SPECIFICATIONS

JIC Flare Torque Values			
Turns	Size	ft-lb min-max	Assembly Steps
N/A	-02	6-7	<p>Make sure the tubing and threads are clean.</p> <p>Lubricate the threads with 10W hydraulic fluid.</p> <p>Hand tighten the nut/sleeve to approximately 30 in-lb.</p> <p>Make alignment marks on the nut and fitting.</p> <p>Tighten to turn or torque specification.</p> <p>When fully tightened, make a second set of alignment marks at the fully tightened position.</p> <p><b>NOTE: Torque values specified are for threads lubricated with 10W hydraulic fluid.</b></p> <p>Overtightening will reduce the clamping force resulting in loss of seal and reduction of flow.</p>
N/A	-03	8-9	
2	-04	11-12	
2	-05	14-15	
1-1/2	-06	18-20	
1-1/2	-08	36-39	
1-1/2	-10	57-63	
1-1/4	-12	79-88	
1	-14	94-103	
1	-16	108-113	
1	-20	127-133	
1	-24	158-167	
1	-32	245-258	

O-Ring Boss Torque Values		
Size	ft-lb min-max	Assembly Steps
-02	6-7	<ol style="list-style-type: none"> <li>1. Verify that the port, O-ring, sealing surfaces and threads are clean and free of damage.</li> <li>2. Lubricate the threads and the O-ring with 10W hydraulic fluid.</li> <li>3. For an adjustable ORB, completely back off the locknut and washer.</li> <li>4. Hand tighten the fitting until it contacts the port spotface. Point the elbow or tee in the desired direction and hold.</li> <li>5. Torque to specification.</li> </ol> <p><b>NOTE: Torque values specified are for threads lubricated with 10W hydraulic fluid.</b></p>
-03	8-10	
-04	13-15	
-05	17-21	
-06	22-25	
-08	40-43	
-10	43-57	
-12	68-75	
-14	90-99	
-16	112-123	
-20	146-200	
-24	154-215	
-32	218-290	

## MOLDBOARD & A-FRAME ASSEMBLY

1. Remove the dust cap from both of the slide box cylinders located at the center/rear of the moldboard. Attach one 9/16" male ORB connector to both ports on each slide box cylinder. Tighten fittings per torque chart.

**NOTE: All of the hydraulic adapters can be found packaged with the manifold assembly.**

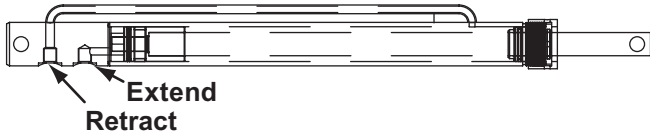

**NOTE: The hoses that operate the retract functions (rod) of the cylinders are closest to the base of each cylinder. The hoses that operate the extend functions (base) of the cylinders are closest to the rod of each cylinder.**

2. Connect hoses (**49501**) to each of the hydraulic adapters on the cylinders. Tighten hoses per torque chart.

**NOTE: Review the label on each hose for the appropriate part number.**

3. Position the pivot beam and A-frame near the mount locations at the rear of the blade. Place the right and left group of hydraulic hoses (connected to the slide box cylinders) through the 1-1/2" diameter rubber grommet openings in the front face of the pivot beam.

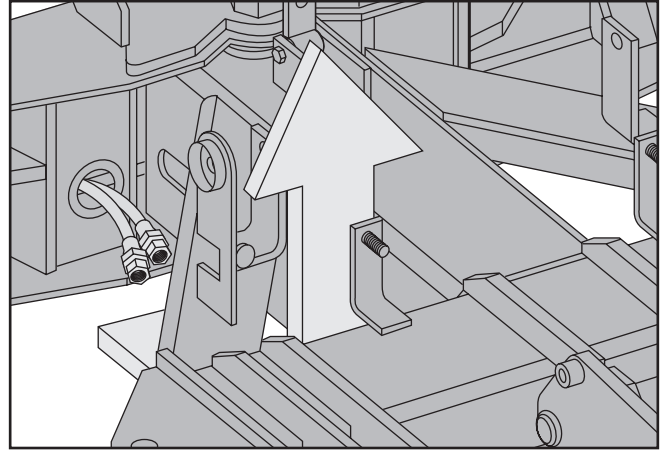

Feed each group of hoses (two per side) through the grommets in the pivot beam and up through the openings in the A-frame. Positioning the hoses through the pivot beam supports the hoses while the snowplow is in use and prevents them from dragging on the ground.

4. Position the pivot beam between the two support ribs until the connecting points on the beam align with those on the snowplow. Insert one 3/4" x 3" clevis pin (**B50069**) or 1" x 3-1/4" clevis pin (**B61717**) through each mounting hole and secure it with a 1/4" x 1-1/2" cotter pin (**90601**).

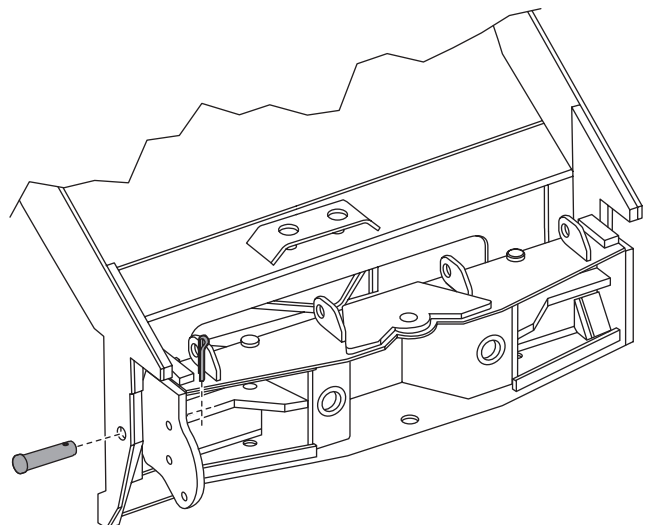

## MOLDBOARD & A-FRAME ASSEMBLY

5. Mount the kickstand to the end of the pivot beam (driver-side) using the 1/2" x 4-1/2" carriage bolt provided. The spring, bushing and locknut are located on the inside of the pivot beam. Review the diagrams below and to the right. To pivot the kickstand, pull the spring-loaded leg out and rotate it until the pin locks into place. Adjust the foot on the stand arm so that the foot is 1/8" from the ground when the A-frame is level and the A-frame mount points are 12-1/2" from the ground. Tighten both of the locknuts on the kickstand.

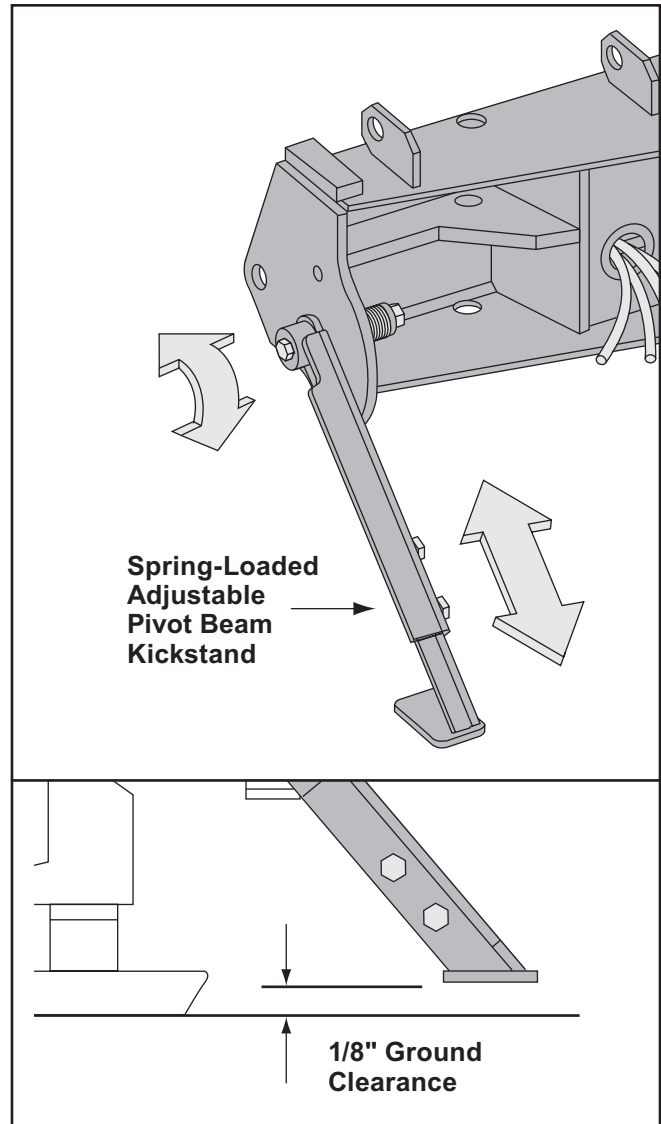
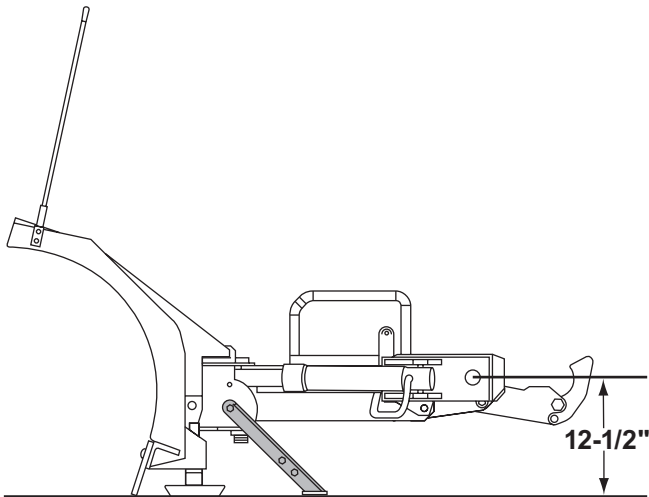

## MOLDBOARD & A-FRAME ASSEMBLY

- Position each angle cylinder with the rod end of the cylinder in the pivot beam and the hydraulic hose port facing away from the A-frame. Secure the cylinder to the pivot beam with a 3/4" x 5" clevis pin (**B41051**) and a 1/4" x 1-1/2" cotter pin (**B61357**). Extend each cylinder rod until the cylinder base mounting hole aligns with the hole on the A-frame angle cylinder bracket. Insert another clevis pin and secure it with a cotter pin.
- Remove the dust cap from both of the hydraulic angle cylinder ports and attach one 9/16" 90° adjustable elbow ORB adapter (**56590**) to each port. Each adapter should be angled toward the top of the moldboard. Connect one 3/8" x 24" (26" for 8611) hydraulic hose (**B60091** or **B60223**) to each angle cylinder adapter. Be careful not to overtighten the hose connections. Route both hoses over the TOP of each cylinder. This will prevent them from hanging or being pinched. Tighten fittings and hoses per torque chart.

- Remove the plastic dust caps from the hydraulic lift cylinder ports. Attach one 9/16" 45° adjustable elbow ORB adapter (**56695**) to the driver-side port (base end) and one 9/16" male ORB connector adapter (**B60007**) to the passenger-side port (rod end). Once the adapters have been installed on the cylinder, connect the hydraulic hoses. Tighten fittings and hoses per torque chart.

**NOTE: Position the 45° fitting in the cylinder port so that the hoses install directly in the center of the A-frame access holes. A hose installed too close to the edge of the opening may work itself free with the operation of the lift cylinder and/or movement of the snowplow.**

The 45° adapter receives a 3/8" x 17" hydraulic hose (**B60273**). Connect the 45° angle on the hose to the hydraulic adapter on the cylinder. The male connector adapter receives a 3/8" x 15" hydraulic hose (**B60274**). Connect the 45° end of the hose to the hydraulic adapter on the cylinder. Both hoses should be routed through the triangular openings in the A-frame. Tighten fittings and hoses per torque chart.

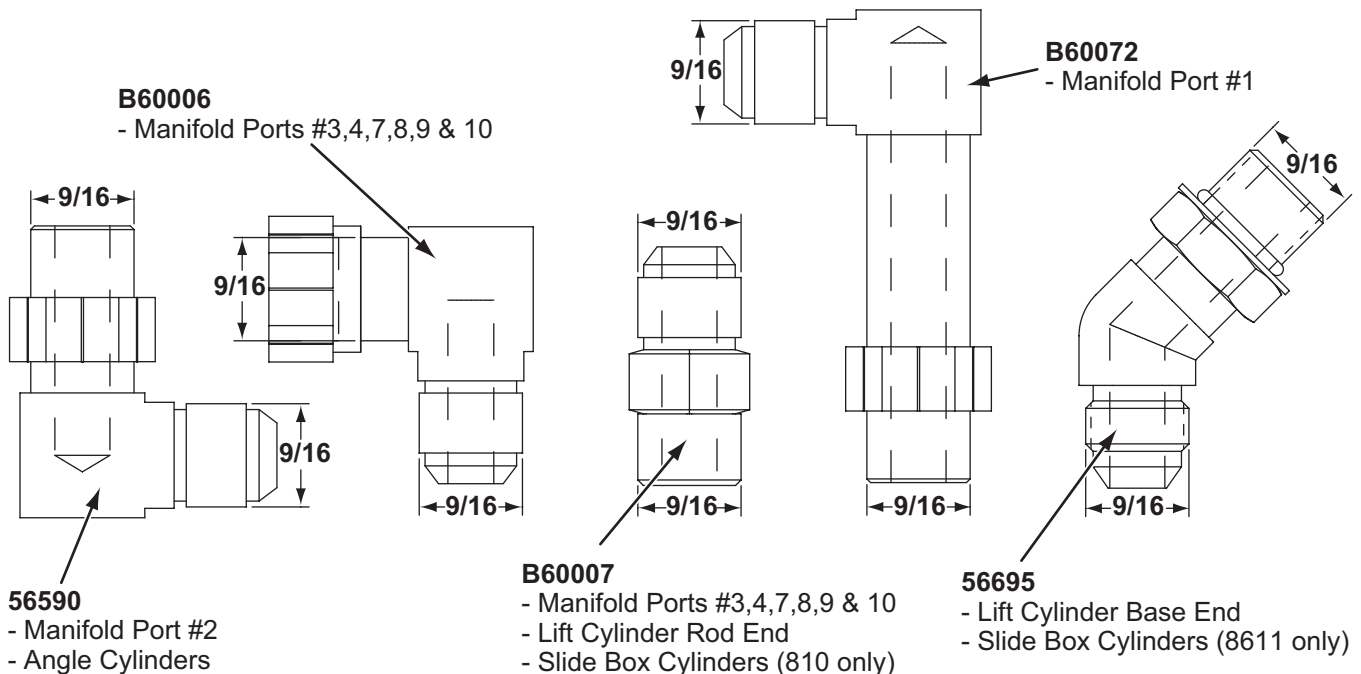

## MOLDBOARD & A-FRAME ASSEMBLY

9. Remove the draw latch mount pin, spacer and cotter pin from the draw latch assembly. By removing this pin, the inner draw latch plates can swing free. Remove the inner draw latch plate lift cylinder mount pin. Position the plates on either side of the lift/lower cylinder rod and insert the pin through the plates and cylinder rod. With the cylinder connected to the inner draw latch plates, rotate the draw latch assembly toward the draw latch mount holes on the A-frame. Align the holes in the outer draw latch plate with those of the inner draw latch plates and the A-frame.

**NOTE: The A-frame latch, located at the rear/center of the A-frame, should be raised up to insert the draw latch mount pin. Pull the A-frame latch pull pin out and rotate the latch counterclockwise if it is locked into position.**

Secure the assembly to the A-frame by replacing the draw latch mount pin, spacer and cotter pin. Reset the A-frame latch so the A-frame latch pin locks into place.

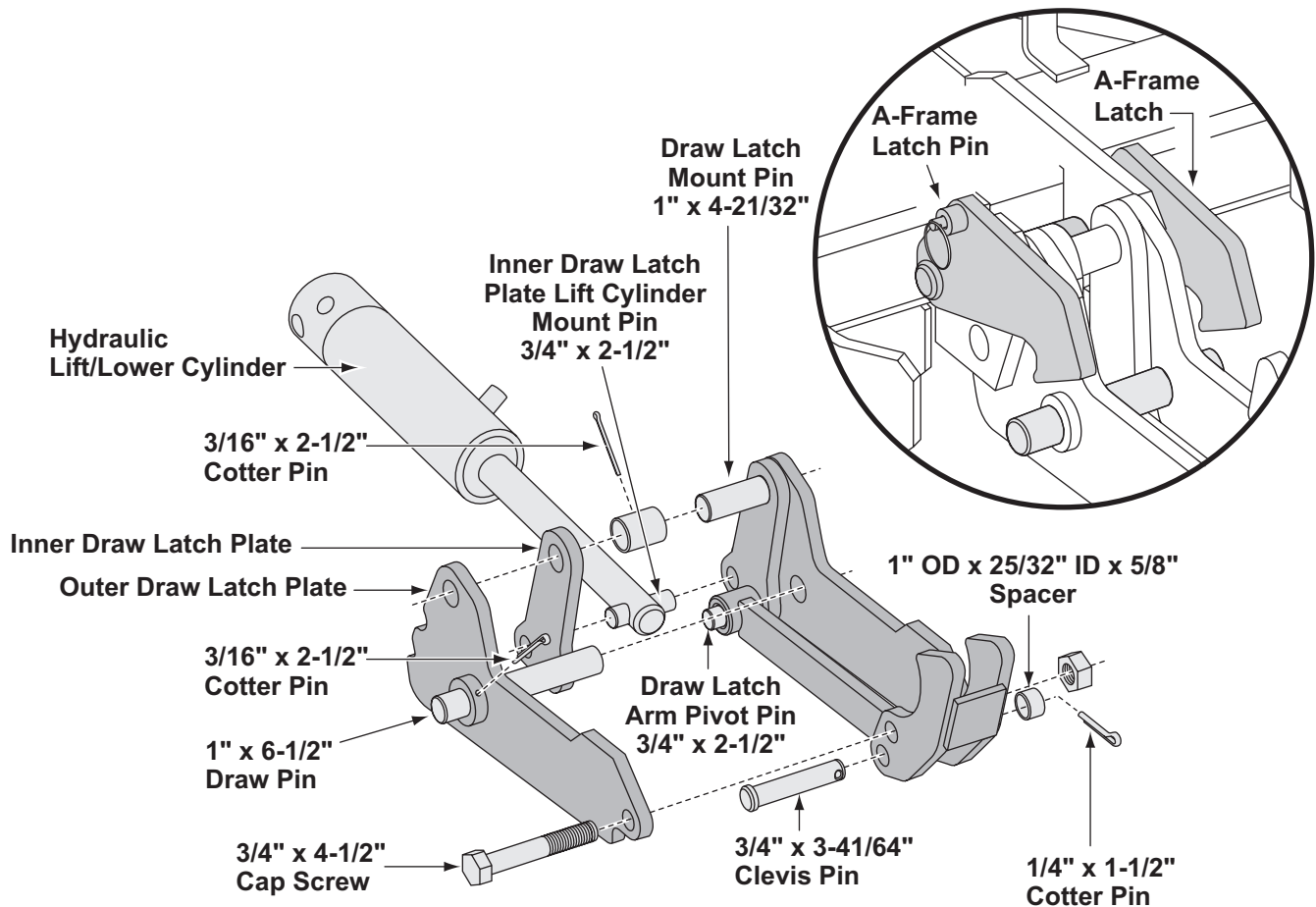

## MOLDBOARD & A-FRAME ASSEMBLY

10. Assemble the manifold. The manifold, pump and coil harness have been connected at the factory; however, the manifold contains several components that you will need to install prior to securing the assembly to the A-frame. Each of the hose ports on the manifold is covered with stretch wrap. Remove the wrap and install the appropriate fitting in its respective port. Tighten fittings and hoses per torque chart.

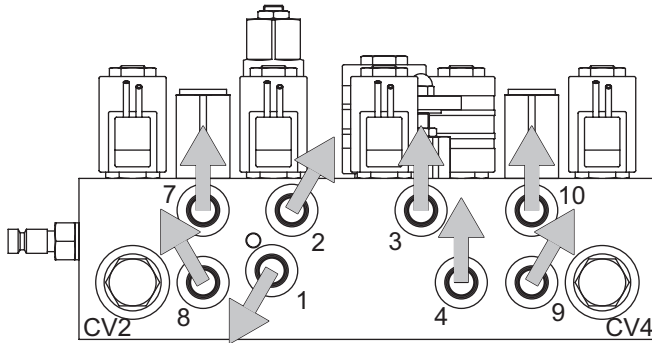

**NOTE:** The arrows shown on the manifold illustration indicate the direction the 90° adapters should be positioned to receive the hydraulic hoses.

**NOTE:** DO NOT let any foreign objects enter into the open ports. The valves can become contaminated and greatly hinder the snowplow's performance. Torque to proper specifications.

**NOTE:** All ports are identified by a stamped number on the manifold. The numbers also identify the hydraulic functions, which can be referenced on the label under the hydraulic pump and manifold cover.

11. Align the mount holes in the pump with the holes in the hinged bracket, located on the A-frame.

**NOTE:** Before mounting the pump, angle the hinged bracket as needed and tighten the bracket hardware to lock it in place.

Secure with 3/8" x 3/4" cap screw and 3/8" flat washer through the top mount hole in the bracket and into the pump. Insert 3/8" x 1-3/4" threaded stud with 3/8" locknut through the bottom mount hole in the bracket and into the pump. The threaded stud should bottom out in the pump.

**NOTE:** When installing the manifold between the mount brackets on the A-frame, hold the manifold at the sides of the block. Never handle the manifold by the coils. Doing so can cause a solenoid cartridge to bend, causing the cartridge to stick when activated.

**NOTE:** A medium-strength threadlocking compound should be used on both of the pump mount fasteners.

12. Connect the hydraulic hoses to their respective adapters on the manifold. Hose PN B60091 or B60223 Ports #1 and #2, Hose PN B60273 Port #3, Hose PN B60274 Port #4, Hose PN 49501 Ports #7 and #10, Hose PN 49501 Ports #8 and #9. Tighten hoses per torque chart.

**NOTE:** All hoses, except #1 and #2 (angle cylinders) should be routed through the triangular openings in the A-frame. Position these hoses over the A-frame angle and to their respective manifold ports.

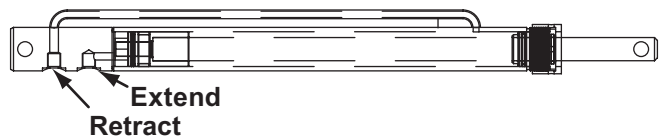

**NOTE:** The hoses that operate the retract functions (rod) of the cylinders are closest to the base of each cylinder. The hoses that operate the extend functions (base) of the cylinders are closest to the rod of each cylinder.



## MOLDBOARD & A-FRAME ASSEMBLY

13. Secure the manifold to the A-frame. Remove the washers, split lock washers and cap screws from the manifold and align the mount holes with the A-frame brackets. Properly replace and tighten all hardware.

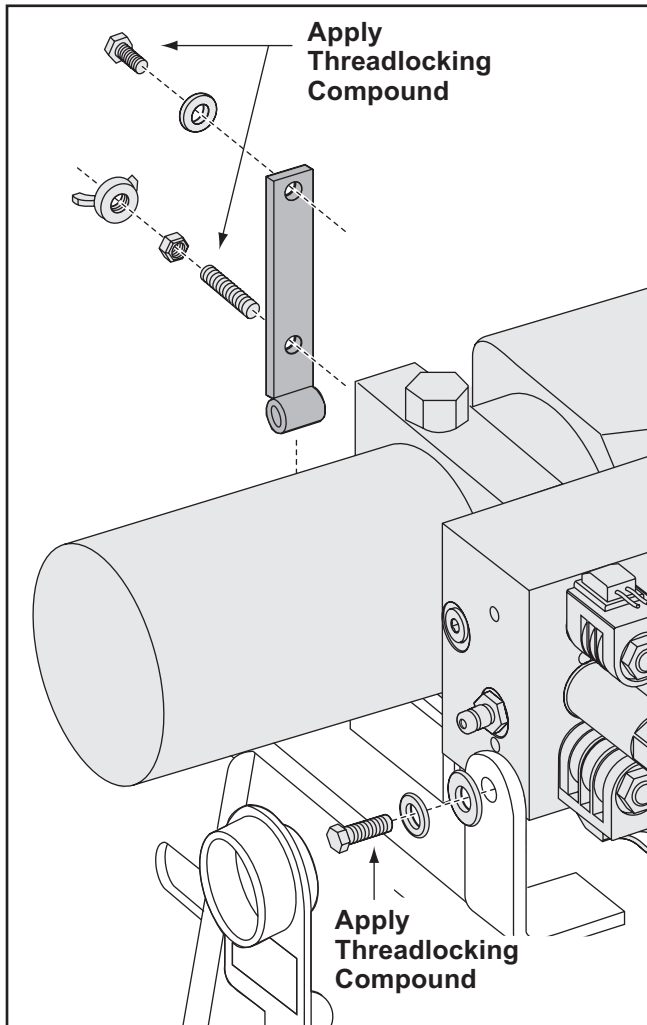

**NOTE: A medium-strength threadlocking compound should be used to secure the manifold mount fasteners.**

14. Hook each extension spring to the receiving holes on the pivot beam and attach the opposite end of the spring to its respective spade bolts. Install the spade bolts through the extension spring mounting angle on the top rear of the blade. Secure each spade bolt by placing one 5/8" flat washer on the bolt and thread one 5/8" locknut. Tighten each locknut until a piece of paper can pass between the 3rd and 4th coils on the spring.

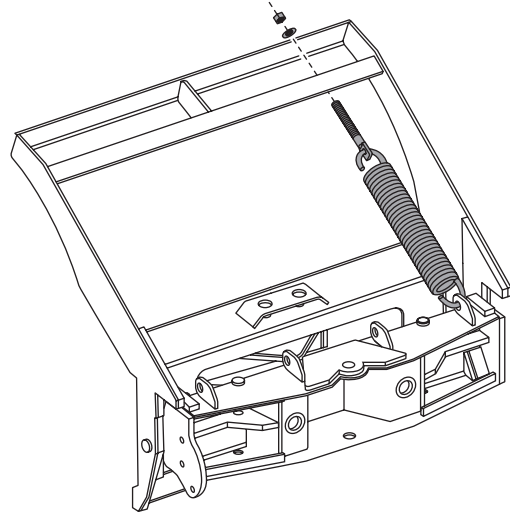

15. Install the blade guides at each end of the moldboard. Insert the cap screw through the holes at the top of the wing reinforcement rib. Tighten all screws with locknuts.

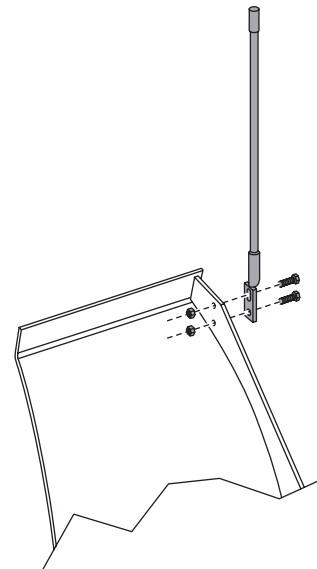

# GENERAL SYSTEM SCHEMATICS

## ELECTRICAL SCHEMATIC

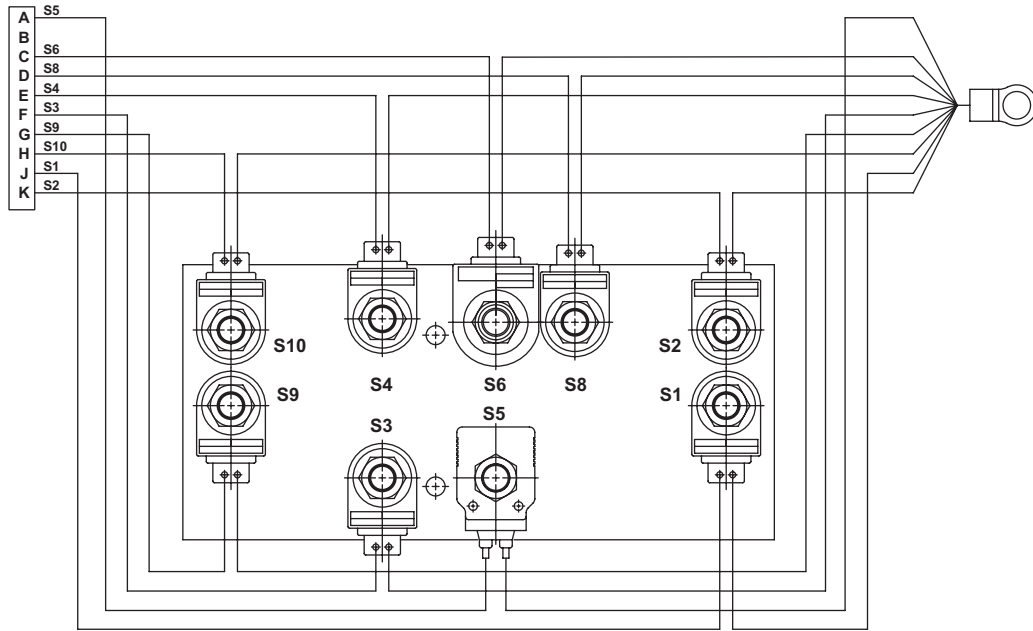

## HYDRAULIC SCHEMATIC

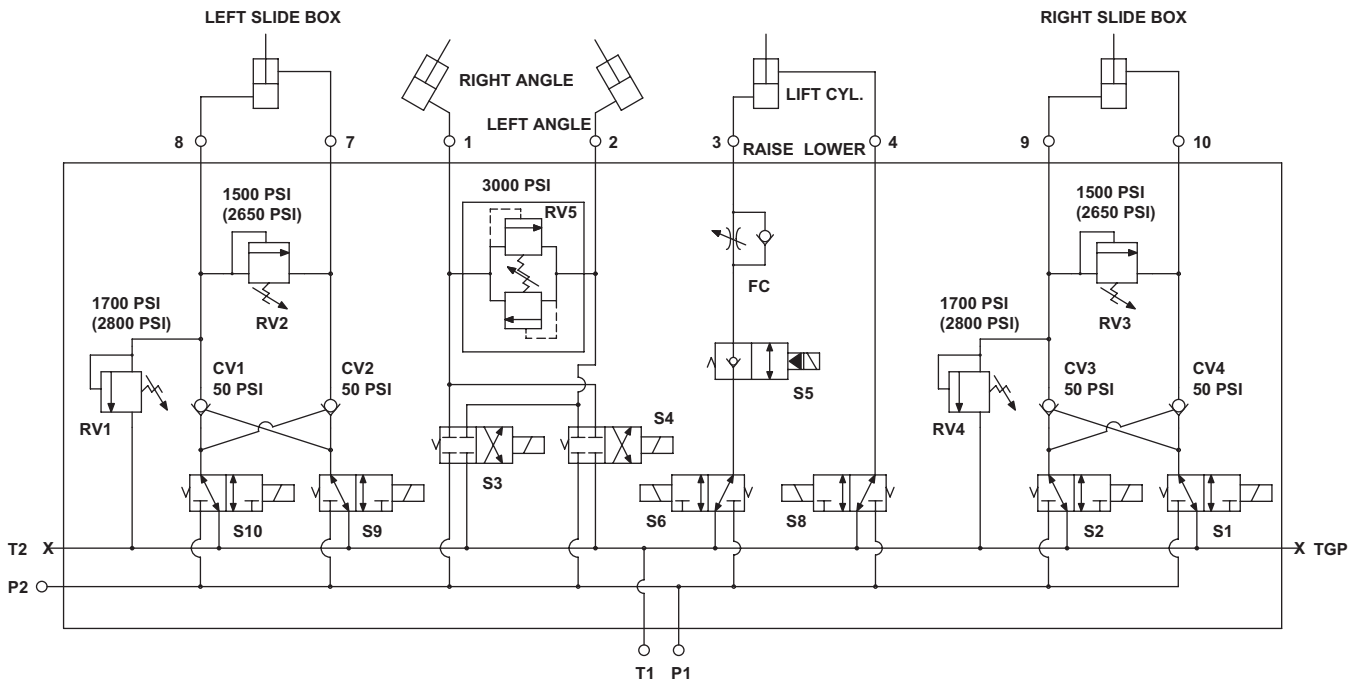

**NOTE:** Where applicable, Model 8611 values are in parentheses.

# Hydraulic Valve & Hose Port Guide

## Models 810 & 8611

If being used with auxiliary hydraulics, recommended for systems having a flow rated at 4–30 gallons per minute (gpm) and a maximum pressure rating of 3,000psi.

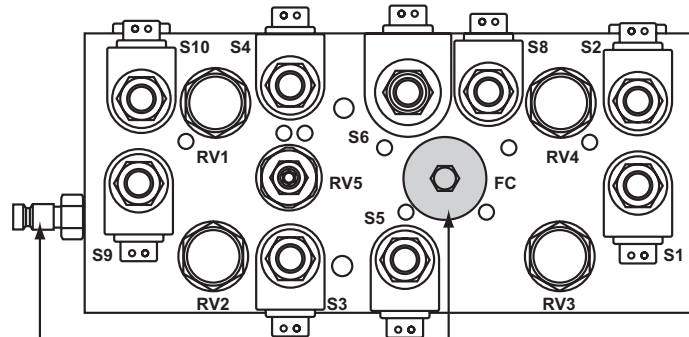

Pressure Gauge Quick Connect

Clockwise – Decrease Snowplow Drop Speed  
Counterclockwise – Increase Snowplow Drop Speed

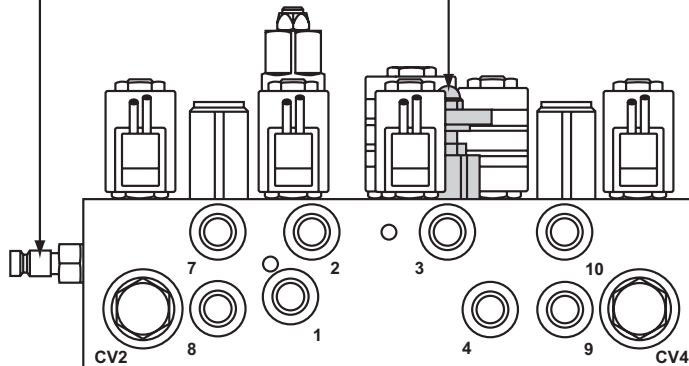

NOTE: Check valves CV1 & CV3 are not illustrated. Both valves are located on the opposite side of the manifold in the diagram shown above.

HYDRAULIC HOSES	
Port	Function
1	Angle Right – Driver-Side Cylinder
2	Angle Left – Passenger-Side Cylinder
3	Raise – Lift Cylinder (Base)
4	Lower – Lift Cylinder (Rod)
7	Driver-Side Slide Box Retract
8	Driver-Side Slide Box Extend
9	Passenger-Side Slide Box Extend
10	Passenger-Side Slide Box Retract
RELIEF & CHECK VALVES	
Valve	Function
RV1	Driver-Side Wing Pressure Relief
RV2	Driver-Side Wing Anti-Cavitation
RV3	Passenger-Side Wing Anti-Cavitation
RV4	Passenger-Side Wing Pressure Relief
RV5	Angle Relief
CV1	Driver-Side Wing Check Valve
CV2	Driver-Side Slide Box Check Valve
CV3	Passenger-Side Wing Check Valve
CV4	Passenger-Side Slide Box Check Valve
VARIABLE FLOW CONTROL VALVE	
Valve	Function
FC	Snowplow Drop Speed Adjustment
<b>NOTE: Energize the following solenoids for the functions:</b>	
S1	Passenger-Side Slide Box Retract
S2	Passenger-Side Slide Box Extend
S3	Angle Left – Passenger-Side Cylinder
S4	Angle Right – Driver-Side Cylinder
S5	Float
S6	Raise – Lift Cylinder (Base)
S5 & S8	Lower – Lift Cylinder (Rod)
S9	Driver-Side Slide Box Retract
S10	Driver-Side Slide Box Extend



Milwaukee, Wisconsin 53224

B63100

# HARNESS PLUGS

## BLIZZARD® HARNESS PLUG (VEHICLE) UNIVERSAL 14 + 2 MOLD

PIN NO.	COLOR	FUNCTION	AWG
1	BLACK	GROUND	4
2	BLACK	GROUND	18
3	RED	12 VOLT DC (+)	4
4	BROWN/WHITE	PUMP SOLENOID TO RING	18
5	BROWN	PUMP SOLENOID TO MOLEX	18
6	RED/WHITE	RIGHT SLIDE BOX EXTEND	18
7	RED/BLACK	RIGHT SLIDE BOX RETRACT	18
8	BLUE/WHITE	LEFT SLIDE BOX EXTEND	18
9	BLUE/BLACK	LEFT SLIDE BOX RETRACT	18
10	BLUE	LEFT ANGLE	18
11	LT. GREEN	RIGHT ANGLE	18
12	WHITE	LIFT	18
13	ORANGE	FLOAT	18
14	N/A	N/A	N/A
15	N/A	N/A	N/A
16	N/A	N/A	N/A
17	PINK/BLACK	12 (+) VDC FUSED	18
18	N/A	N/A	18

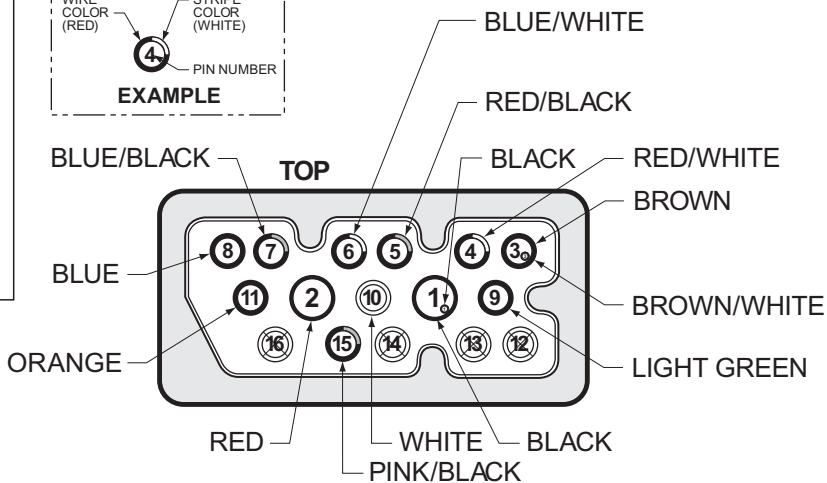
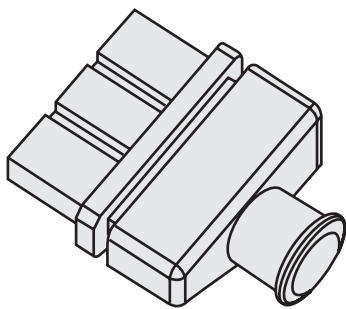
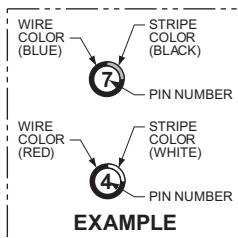

## BLIZZARD HARNESS PLUG (PLOW)

PIN NO.	COLOR	FUNCTION	AWG
1	BLACK	GROUND	4
2	N/A	N/A	N/A
3	RED	12 VOLT DC (+)	4
4	BROWN	PUMP SOLENOID	18
5	RED/WHITE	RIGHT SLIDE BOX EXTEND	18
6	RED/BLACK	RIGHT SLIDE BOX RETRACT	18
7	BLUE/WHITE	LEFT SLIDE BOX EXTEND	18
8	BLUE/BLACK	LEFT SLIDE BOX RETRACT	18
9	BLUE	LEFT ANGLE	18
10	LT. GREEN	RIGHT ANGLE	18
11	WHITE	LIFT	18
12	ORANGE	FLOAT	18
13	N/A	N/A	N/A
14	N/A	N/A	N/A
15	N/A	N/A	N/A
16	PINK/BLACK	12 (+) VDC FUSED	18
17	N/A	N/A	18

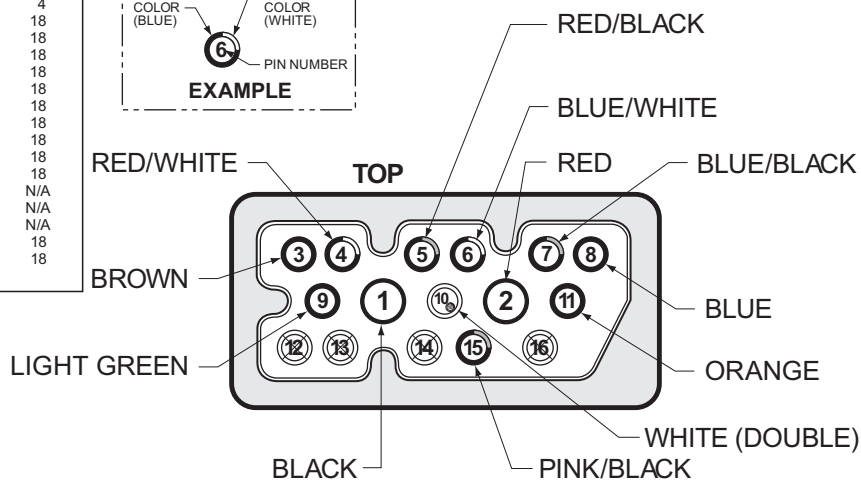
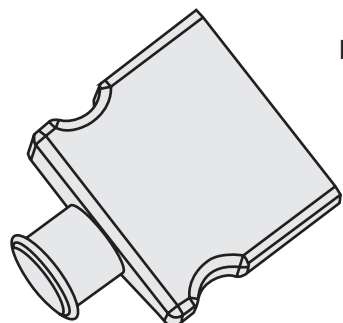
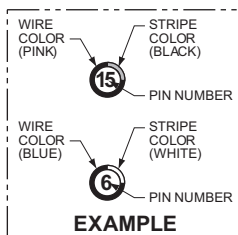

## ELECTRICAL INSTALLATION — SNOWPLOW SIDE

---

1. Connect the red power wire from the snowplow harness to the pump motor terminal stud. Hardware provided on pump.
2. Place the 3/8" lock washer, the black ground wire (from the harness) and the red ground wire on the coil harness (from the manifold) over the tapped hole on the pump and secure with 3/8" x 3/4" screw.
3. Remove the nut and washer from the POWER HITCH™ connect/disconnect toggle switch and insert it through the back of the mounting bracket on the A-frame. Align the notches on the switch and bracket. Replace the washer and nut and tighten until the switch is firmly in place. Attach the connector on the snowplow harness to the switch.

---

**NOTE: Use caution when connecting. Switches can break if this is done forcefully.**

---

4. Attach the connector on the harness to the connector on the coil harness.
5. Position the harness braid in the notch on the switch bracket and secure it with a cable tie.

---

**NOTE: The diode loop harness should be inside of the pump cover.**

---

6. Install the pump and manifold cover by aligning the notches in the cover with the welded bolts on the A-frame brackets. Secure with clamping knob. Verify that the cover is positioned over the protective toggle switch hood. Pop the front of the cover on the threaded stud and secure it with the remaining knob.

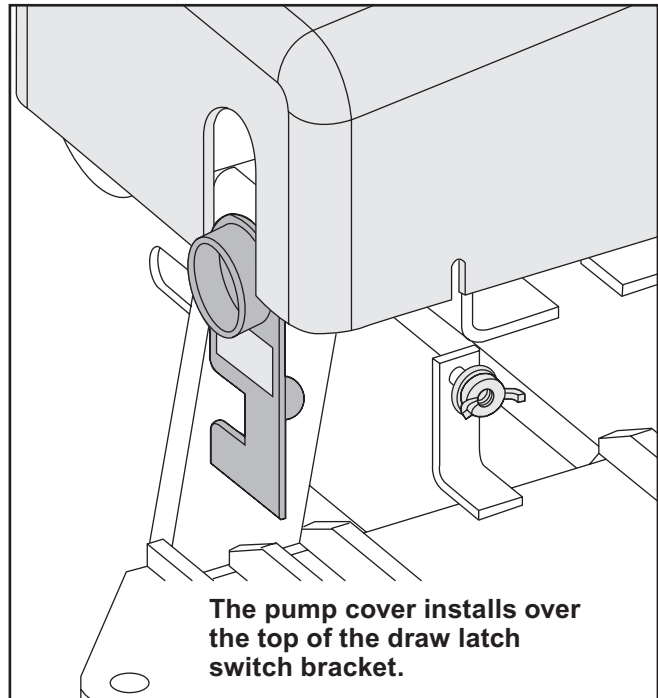

# ELECTRICAL SCHEMATICS — SNOWPLOW SIDE

## PLOW HARNESS (B62039)

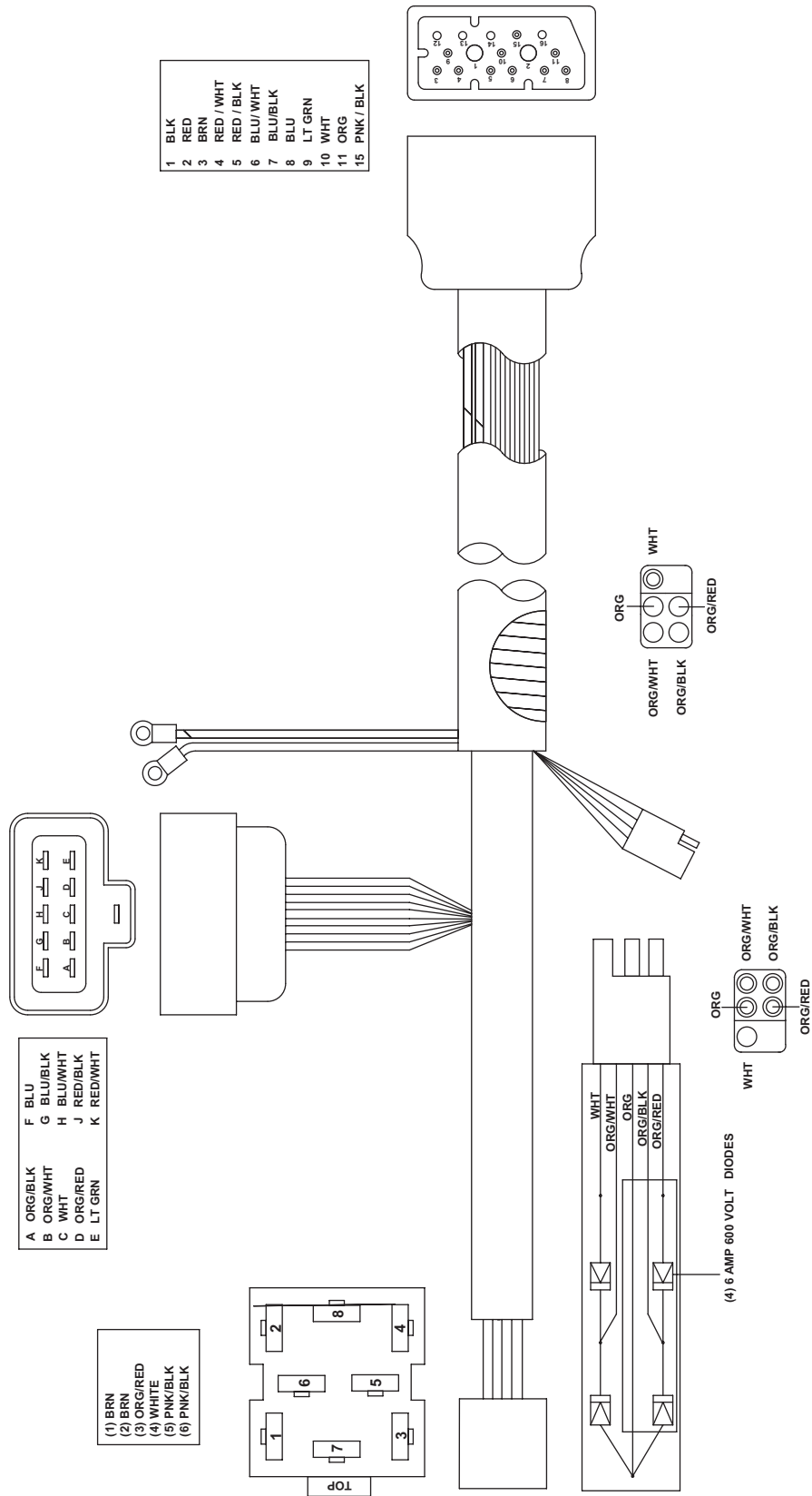

FLOW WIRE HARNESS SCHEMATIC (B62039)

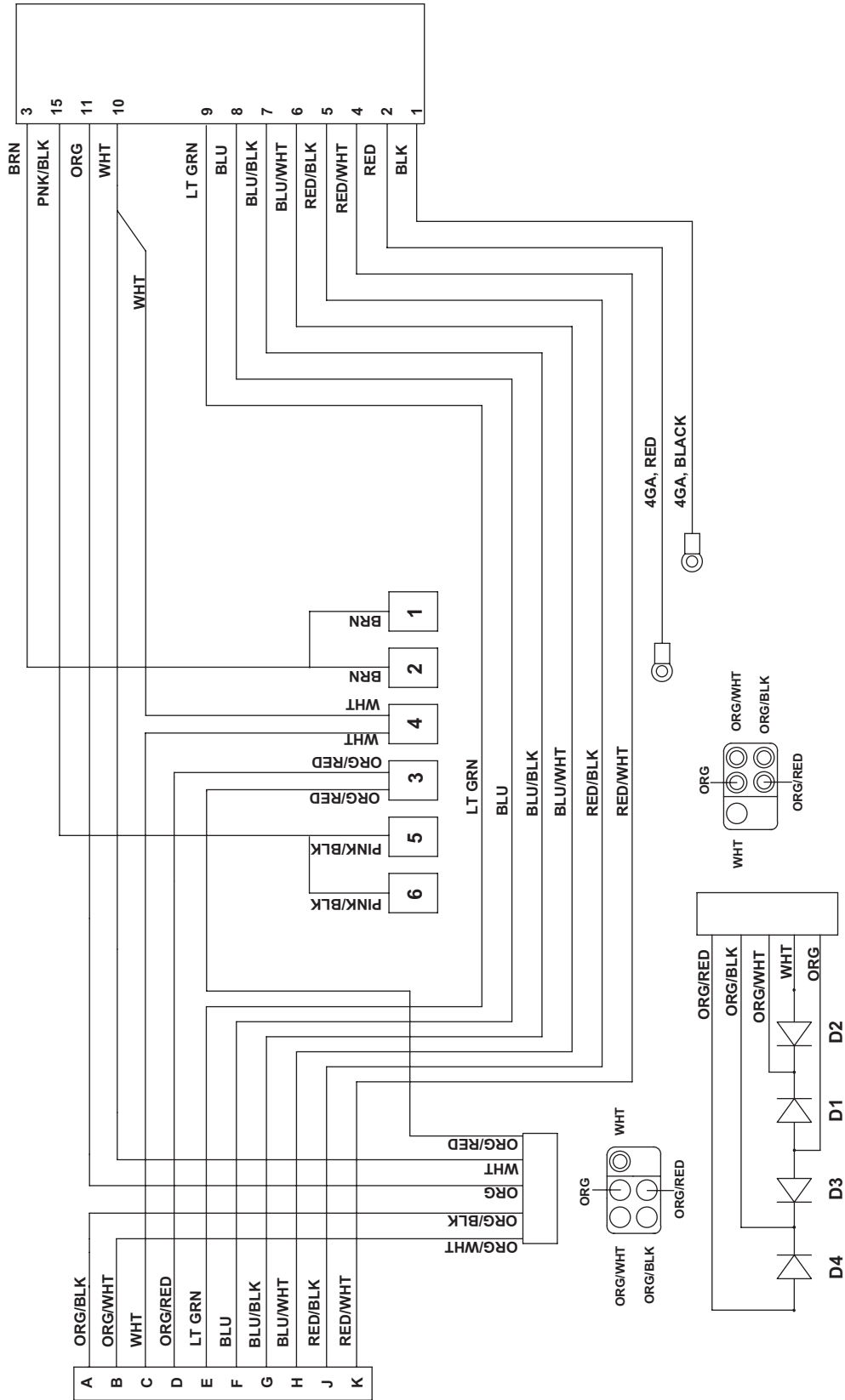

## ELECTRICAL INSTALLATION — VEHICLE SIDE

### **⚠ CAUTION**

**Before drilling any holes, check the selected area for wires, hoses or other obstructions.**

1. With the large plug on the electrical harness placed near the tow hook, under the bumper, route the harness over the driver-side fender well and to the fire wall. Insert the connector end of the harness through an existing hole in the fire wall and into the vehicle cab. If an access hole does not exist, drill an appropriately sized hole through the fire wall in a convenient location away from sharp edges and hot or moving parts.

**NOTE: Keep the snowplow plug and vehicle connector pins lubricated with a liberal amount of dielectric grease. Always replace the protective weather caps when the snowplow is disconnected from the vehicle.**

2. Attach the power contactor (solenoid) to the driver-side wheel well or engine fan guard using #12 x 3/4" self-drilling screws.

**NOTE: Some model vehicles provide mounting locations for accessory components.**

Always mount the solenoid with the terminals facing up, for extended solenoid life. Connect the 24" black ground wire to either small terminal on the solenoid and attach the opposite end to the vehicle with a self-drilling screw. Cut the brown/white pump activation wire on the harness to length. Strip the end of the harness and crimp

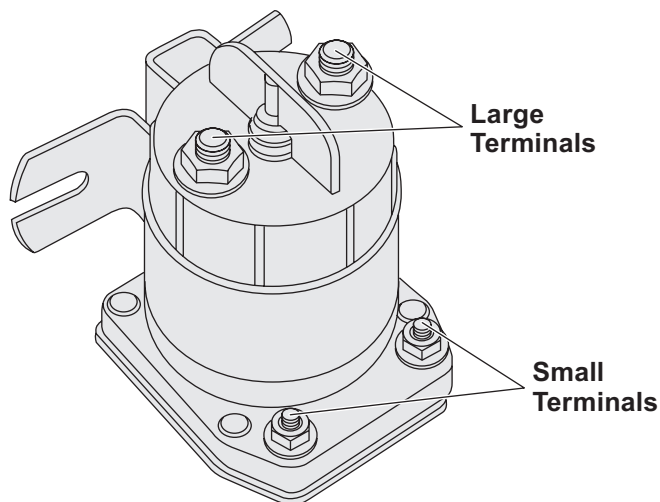

the eyelet terminal onto it. Attach the eyelet to the remaining small terminal on the contactor. Secure it with the hardware provided on the solenoid.

**NOTE: Do not fasten the harness to areas that come in contact with moving engine parts or become extremely hot. The harness could become tangled and/or melt causing electrical failure and vehicle damage.**

3. Connect the vehicle harness ground wire to the NEGATIVE (-) terminal on the vehicle's battery. Cut the plain wire to length and strip the end of the wire. Crimp and solder a 3/8" ring terminal on the wire.

**NOTE: The harness should be secured to the vehicle prior to taking the necessary measurement.**

Measure the distance needed for the power wire to reach the solenoid. Strip the wire, then crimp and solder an end ring terminal to it. Connect the power wire to either large terminal on the solenoid.

4. Strip both ends of the remaining length of red wire, then attach and solder an end ring terminal to both. Connect one end of the wire to the open terminal on the solenoid and the remaining end to the POSITIVE (+) terminal on the battery.
5. Position the main lighting harness with both of the truck headlamp connectors near each truck headlamp and the snowplow headlamp connectors near the grille of the vehicle.
6. Plug the headlamp ground/relay connector from the vehicle harness into the connector on the main lighting harness. Securely mount the relay receptacles to the vehicle with the terminal wires facing down and the relays facing up. Installing the relays in this position will allow moisture to drain from the relay.



## ELECTRICAL INSTALLATION — VEHICLE SIDE

7. Remove the front signal lamp assembly from both sides of the vehicle. On the driver's side, feed the violet (turn lamp) and gray (run lamp) wires from the main lighting harness through the opening in the signal lamp housing. Use a test light or ohmmeter to determine the proper wires in the vehicle's electrical system to splice into. Position one end of the turn or run lamp wire into the splice lock connector, and attach the vehicle wire into the opposite side. Complete the splice by pinching both wires together and locking the connector. Repeat the splice procedure for the remaining wire.
8. Repeat Step 7 for passenger's side, using the pink (turn lamp) and gray (run lamp) wires.
9. Connect the vehicle headlamps to the main lighting harness using a headlamp conversion harness kit. Due to differences in the construction of the kits, and the various make and model vehicles BLIZZARD® snowplows are installed on, a headlamp conversion kit is not packaged with your snowplow. Contact your local BLIZZARD outlet to obtain the appropriate conversion harness kit for your vehicle.
10. Secure the braided harness to the vehicle. Safely route all harness lengths around the engine components and attach them to the vehicle with cable ties. Extend the snowplow headlamp connectors from the main lighting harness through the grille of the vehicle and position the harness power plug and weather cap near the bumper. Cable tie the plug to the vehicle bumper or tow hook to keep the harness from hanging too low.
11. Install the remainder of the vehicle wire harness to the interior of the cab. Connect the power wire (with 15-amp fuse) to a switched power source with a minimum of 15 amps.
12. Install the light tower. Position the arms into the receiving pockets located on the undercarriage. Each pocket has a lock pin that secures both light tower arms. Pull out and twist each handle to temporarily unlock the pins. Place the light tower into the pockets and relock the pins. See your local BLIZZARD outlet for complete installation instructions for your vehicle undercarriage.
13. Install the snowplow headlamps. Align one headlamp stud on the light tower tube with the mounting hole and insert the threaded stud through each. Secure the headlamp with one 1/2" galvanized washer (neoprene facing up), one 7/16" lock washer and locknut.

---

**NOTE: All snowplows are shipped with two caps that install on the ends of the light tower.**

---

After adding a liberal amount of dielectric grease, connect the terminals from the snowplow headlamps to the terminals on the main lighting harness.

14. Position the rocker switch/joystick control station on the front radius of the seat. Wrap the hook-and-loop fastener strap around the bench, through the 2" D-ring and fasten. Connect the white power connector from the vehicle wire harness to the connector on the control station. The power switch should be in the middle, or "OFF," position.

---

**NOTE: The operation of the draw latch can only be controlled when the POWER switch is located in the POWER HITCH™ (UP) position and the RAISE/LOWER rocker switch on the A-frame is in the NEUTRAL (CENTER) position.**

---

15. After completing the mechanical and electrical installations, test all snowplow and lighting functions before attempting to drive or plow.

---

**NOTE: The red power wire MUST be fused and switched ON and OFF with ignition.**

---

Secure all loose wires under the dash.



# ELECTRICAL SCHEMATICS — VEHICLE SIDE

## VEHICLE HARNESS (2005)

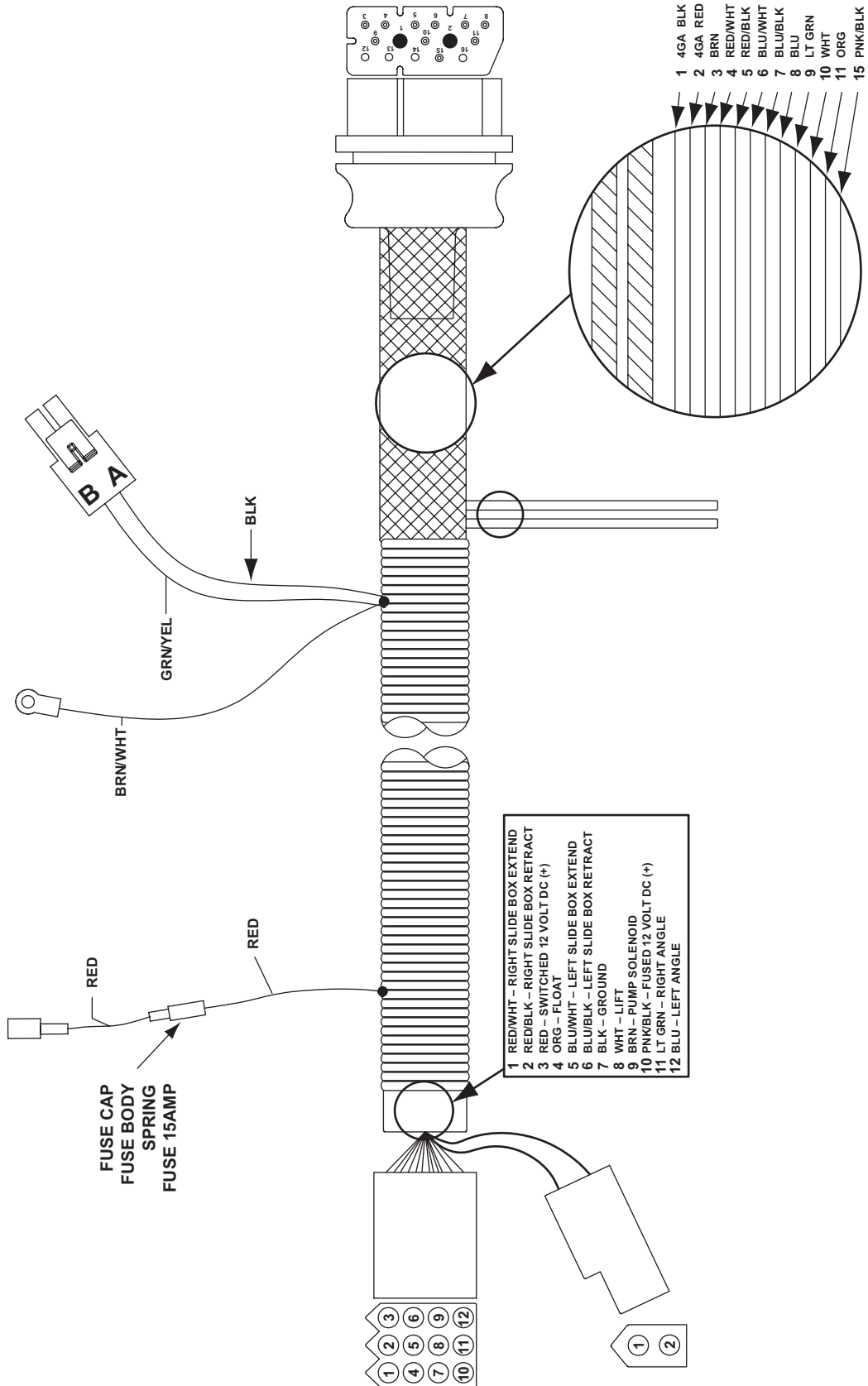

# ELECTRICAL SCHEMATICS — VEHICLE SIDE

VEHICLE HARNESS SCHEMATIC (2005)

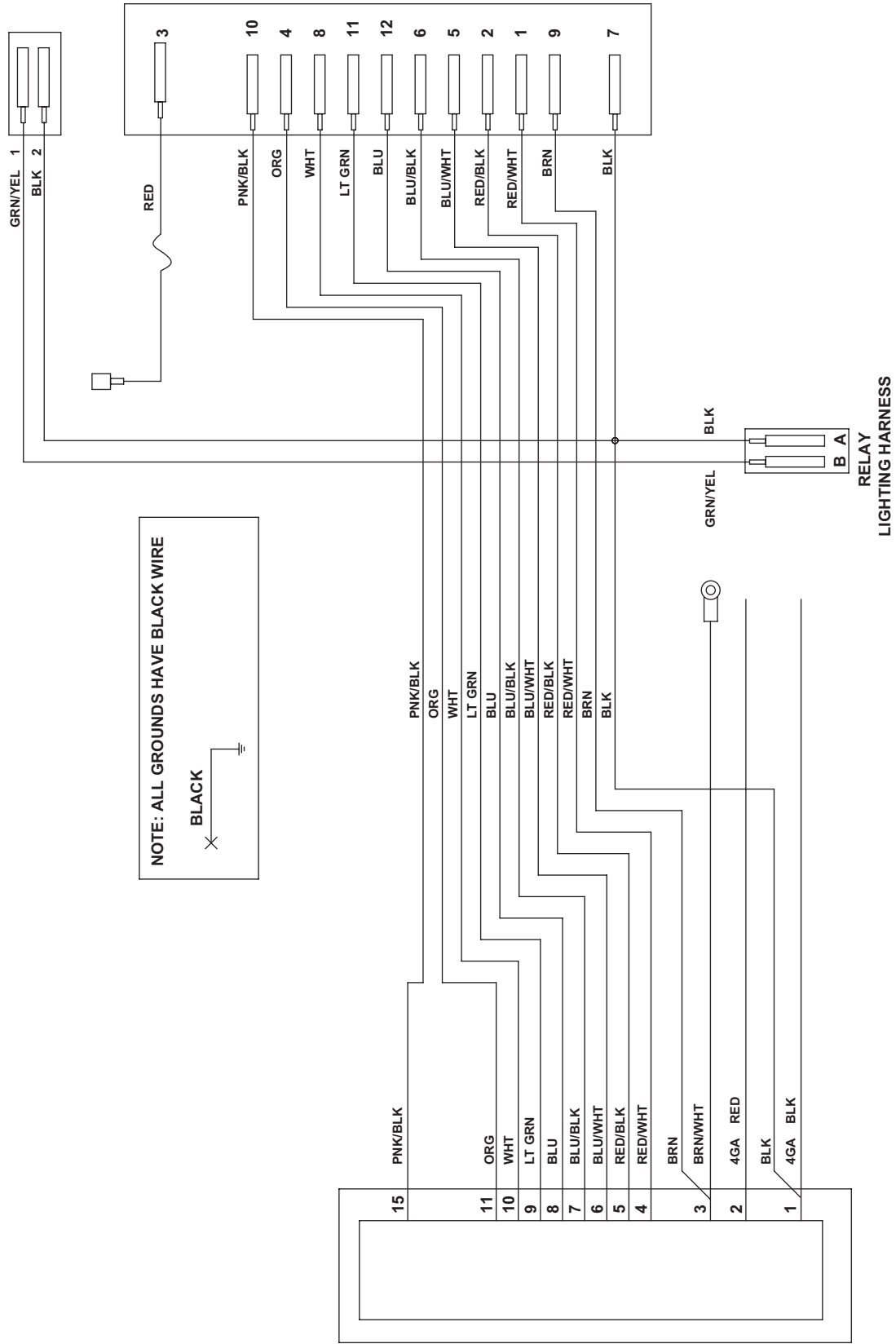

# ELECTRICAL SCHEMATICS — VEHICLE SIDE

## MAIN LIGHTING HARNESS (2005)

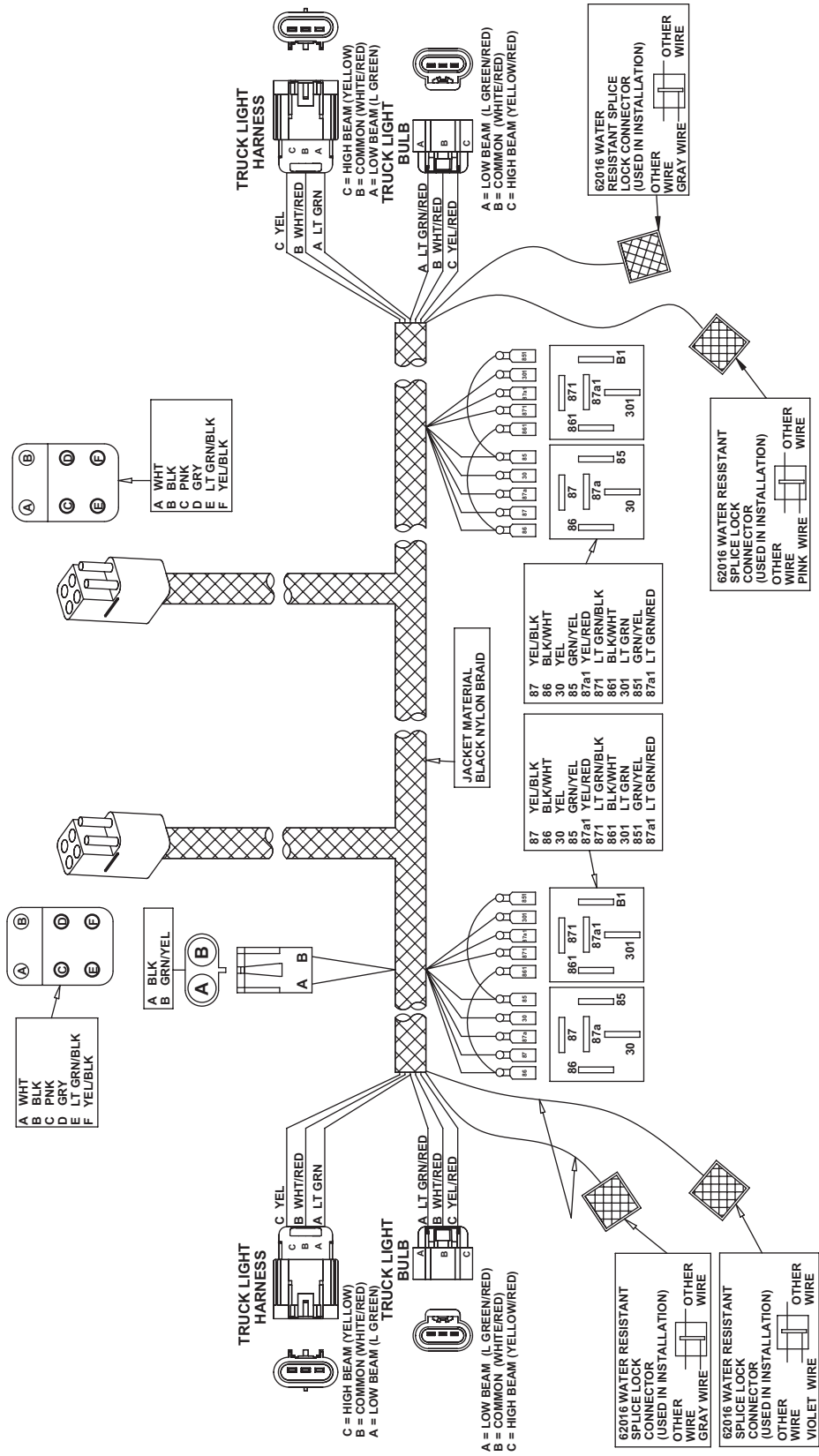

# ELECTRICAL SCHEMATICS — VEHICLE SIDE

## MAIN LIGHTING HARNESS SCHEMATIC (2005)

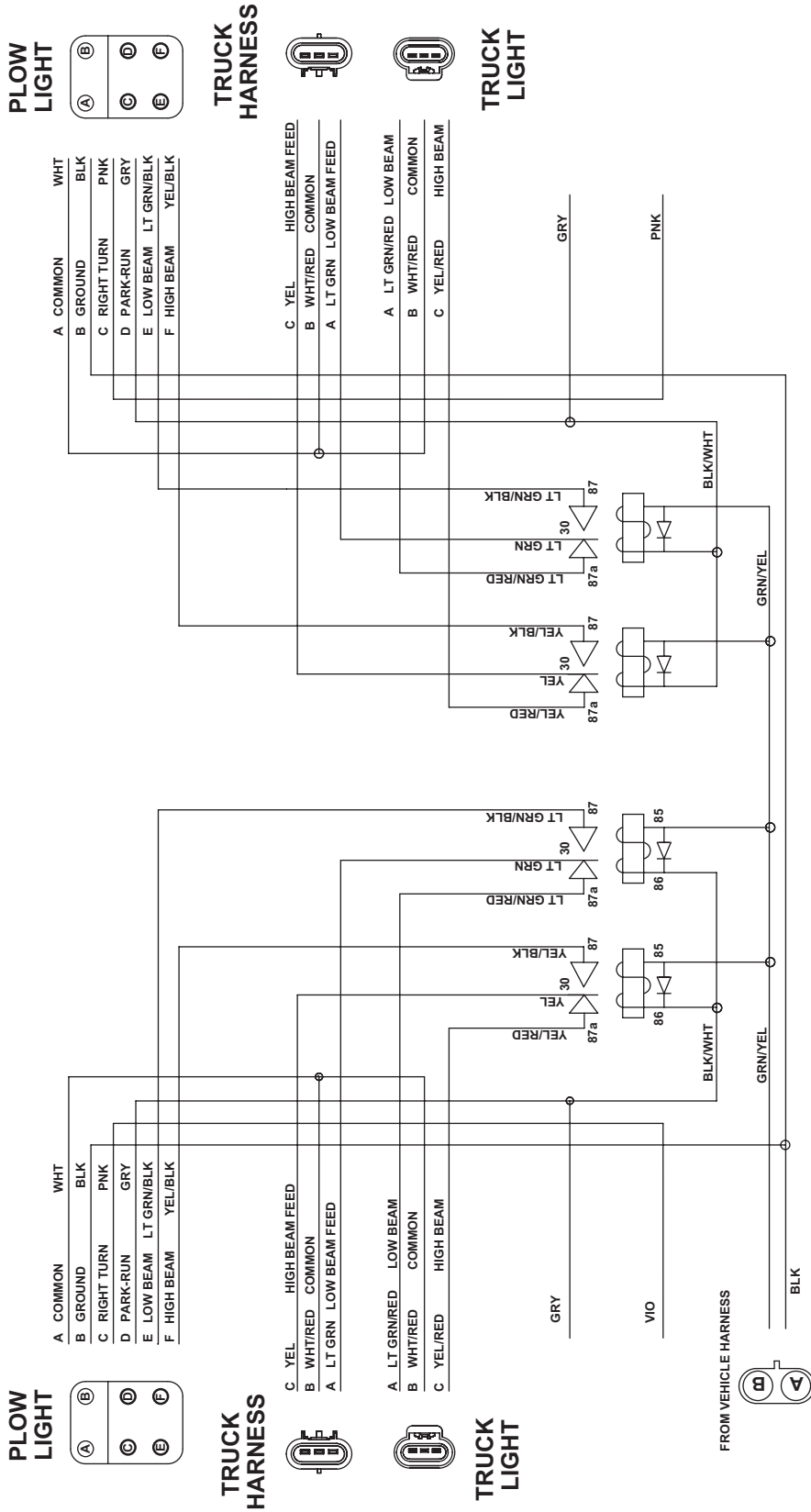

# POWER HITCH™ SYSTEM INSTRUCTIONS

Prior to operating your POWER PLOW™ snowplow, review the Mount and Dismount Instructions label on the back of the driver-side moldboard.

**NOTE: If at any time the Mount and Dismount Instructions label, or any other label attached to your snowplow, becomes illegible, promptly replace it.**

<b>MOUNT INSTRUCTIONS</b>		<b>DISMOUNT INSTRUCTIONS</b>	
Read Owner's Manual for Complete Instructions.		Read Owner's Manual for Complete Instructions.	
<p><b>STEP #1</b></p> <p><b>⚠ WARNING: Keep fingers away. POWER HITCH arm raises behind undercarriage pushbeam.</b></p> <ul style="list-style-type: none"> <li>• Kickstand must be lowered, with kickstand pin seated in lower hole on pivot beam.</li> <li>• Slowly drive vehicle forward until pushbeam receiver mount points contact A-frame mount bushings.</li> <li>• Turn POWER HITCH OPERATION switch (on plow control) to "ON" position.</li> <li>• Connect plow and vehicle electrical harnesses. Connect weather caps together.</li> </ul>		<p><b>STEP #1</b></p> <p><b>⚠ WARNING: Keep fingers away from plow and truck mounting points.</b></p> <ul style="list-style-type: none"> <li>• Raise plow. Lower kickstand until kickstand pin is seated in lower hole on pivot beam.</li> <li>• Lower plow on flat, level surface. Turn vehicle ignition off.</li> <li>• Remove hitch pins from A-frame and undercarriage.</li> <li>• Turn vehicle ignition on.</li> <li>• Turn POWER HITCH OPERATION switch (on plow control) to "ON" position.</li> </ul>	
<p><b>STEP #2</b></p> <ul style="list-style-type: none"> <li>• Pull A-frame latch lock pin out and lower A-frame latch over draw pin.</li> <li>• Push and hold CONNECT/DISCONNECT switch upward. POWER HITCH arm will engage back of pushbeam and pull plow into pushbeam receiver mount points on vehicle.</li> <li>• Insert both hitch pins and secure each with hair pin cotter.</li> <li>• Lower POWER HITCH arm to relieve tension on A-frame latch. Raise A-frame latch and lock into position with lock pin. Raise plow.</li> <li>• Raise kickstand until kickstand pin seats into upper hole on pivot beam.</li> </ul>	<p><b>STEP #2</b></p> <ul style="list-style-type: none"> <li>• Push and hold CONNECT/DISCONNECT switch downward. POWER HITCH arm will disengage from behind undercarriage pushbeam and lower.</li> <li>• Disconnect plow and vehicle electrical harnesses. Install weather caps.</li> <li>• Turn SYSTEM POWER (on plow control) to "OFF" position.</li> <li>• Slowly move vehicle backward away from plow.</li> </ul>		
<p>U.S. Patents 5,638,618; 5,899,007; 6,178,669; 6,276,076; 6,393,737; 6,408,549; 6,412,199; 6,442,877; 6,615,513; Canadian and other patents pending.</p>			

# TESTING YOUR SNOWPLOW

1. Fill the hydraulic pump reservoir with BLIZZARD® Rapid Action Hydraulic Fluid until it is approximately 3/4" from the top of the tank. Replace the cap on the reservoir. Remove the weather caps from each of the snowplow and vehicle harnesses and connect the plugs. Start the vehicle and turn the power switch on the control station in the cab to the "ON" position.

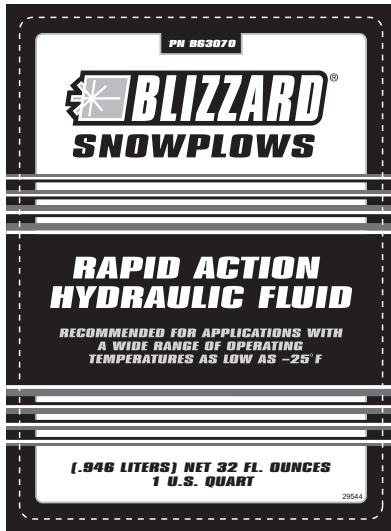

## **⚠ WARNING**

You can die or be seriously injured. Keep hands and feet away from hitch mechanism and snowplow blade when operating the POWER HITCH™ arm. The action of the arm moves the snowplow toward the vehicle and into position for proper attachment.

2. To raise the POWER HITCH arm on the snowplow, turn the power switch on the control station to the "UP" or "ON" position. Push and hold the toggle switch on the A-frame upward into the "CONNECT" position. Notice the action of the fluid in the reservoir. By activating the initial hydraulic function, the fluid begins to fill the system. Push and hold the toggle switch in the "DISCONNECT" position. The POWER HITCH arm will lower. Refill the reservoir until the fluid is approximately 3/4" from the top of the tank.

3. Align the POWER HITCH arm on the A-frame below the pushbeam, with the receiver plates in line with the receiver plates on the undercarriage. Pull out the A-frame latch pin and rotate the A-frame latch clockwise until the latch is resting on the draw pin. Move the snowplow in position by activating and releasing the POWER HITCH connect switch.

The POWER HITCH arm will rise until it hits the push beam and the draw latch fingers will pull the snowplow into the vehicle. The receiver plates on the snowplow and vehicle are now positively aligned. Insert the two hitch pins through the mounting holes on the A-frame and secure each with one hairpin cotter.

After the two hitch pins are inserted through the A-frame, lower the POWER HITCH arm using the toggle switch on the A-frame. Rotate the A-frame latch counterclockwise until the A-frame latch lock pin can be reinserted. Fully reinserting the A-frame latch lock pin will lock the A-frame latch in place for transport or plowing snow. (See below.)

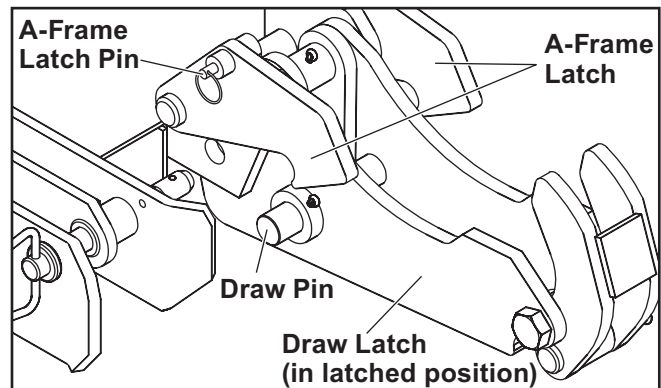

# TESTING YOUR SNOWPLOW

- Return to the interior of the vehicle to test the remaining functions of the snowplow. The system power on the control should be in the "ON" position. Raise the snowplow to its maximum height by pulling the joystick back (or down) or pressing the U button on the touchpad. Initiate the driver-side wing by pushing and holding the LEFT WING EXTEND rocker switch on the joystick, or LEFT WING OUT button on the touchpad, until the wing pivots forward. Notice the staggered pace the wing extends. The hydraulic fluid is filling the hose and replacing the air in the system. Push and hold the LEFT WING RETRACT rocker switch on the joystick, or LEFT WING IN button on the touchpad, to return the wing. Continue testing the remaining rocker switch/button functions. To lower the snowplow to the ground, push the joystick ahead (or up) or push the D button on the touchpad.

**NOTE: The FLOAT function is activated when the joystick is pushed ahead (or up) into the "LOWER" position or the D button is pressed on the touchpad and held there for an additional .5 second after the blade contacts the ground. The LED FLOAT light will come ON when the snowplow is in FLOAT mode.**

Initiate the passenger-side wing by pushing and holding the RIGHT WING EXTEND rocker switch on the joystick, or the RIGHT WING OUT button on the touchpad, until the wing pivots forward. Push and hold the RIGHT WING RETRACT rocker switch on the joystick, or the RIGHT WING IN button on the touchpad, to return the wing. **With both wings retracted**, check the fluid level in the reservoir and fill to 3/4" from the top of the tank, if needed.

- Check for fluid leaks around the manifold, pump, hydraulic hoses and all cylinders. If there are any leaks, turn OFF the power switch on the control and shut OFF the vehicle engine. Tighten any loose connections and/or fittings. Restart the vehicle, cycle through all blade controls, then check to see if all the leaks have been stopped, after turning OFF the control power switch and shutting OFF the vehicle.
- Check that the vehicle and snowplow headlamps are in proper working condition, including the turn signals.

LED Float Light

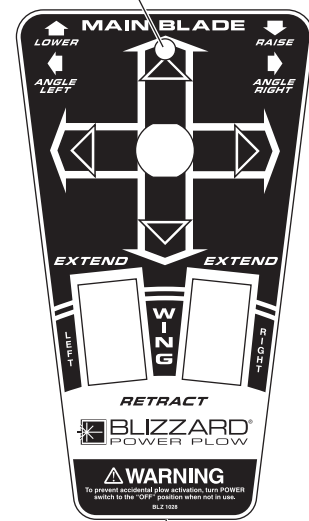

Indicator Light

ON/OFF Switch (Emergency Stop)

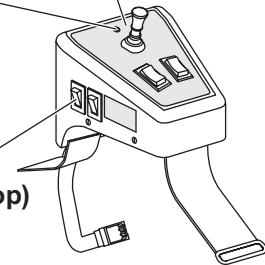

LED Float Light

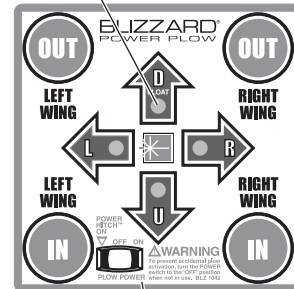

Indicator Light (Backlit)

ON/OFF Switch (Emergency Stop)

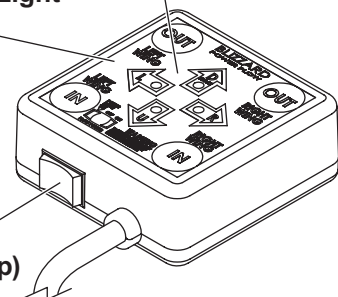



# HEADLAMP AIMING

Fully tighten headlamp fasteners once correct visual aim is achieved.

1. Place vehicle on a level surface 25 feet in front of a matte-white screen, such as a garage door. The screen should be perpendicular both to the ground and to the vehicle centerline.
  2. The vehicle should be equipped for normal operation. The snowplow blade should be in place and in raised position. Below are steps listed by the Society of Automotive Engineers (SAE) pertinent to headlamp aiming in specification #SAE J599d.
  3. Prepare vehicle for headlamp aim or inspection. Before checking headlamp aim, the inspector will:
    - a. Remove ice or mud from under fenders.
    - b. Set tire inflation pressures to the values specified on vehicle information label.
    - c. Check springs for sag or broken leaves.
    - d. See that there is no load in the vehicle other than the driver and ballast as specified in the Undercarriage Selection Guide.
  - e. Check functioning of any automatic vehicle leveling systems and specific manufacturer's instructions pertaining to vehicle preparation for headlamp aiming.
  - f. Clean lenses.
  - g. Check for bulb burnout and proper beam switching.
  - h. Stabilize suspension by rocking vehicle sideways.
4. Mark (or tape) the vertical centerline of the snowplow headlamps and the vertical centerline of the vehicle on the screen. Mark the horizontal centerline of the snowplow headlamps on the screen (distance from ground to snowplow headlamp centers).
  5. Align the top edge of the high-intensity zone of the snowplow lower beam below the horizontal centerline and the left edge of the high-intensity zone on the vertical centerline for each snowplow headlamp. (Refer to diagram below.)

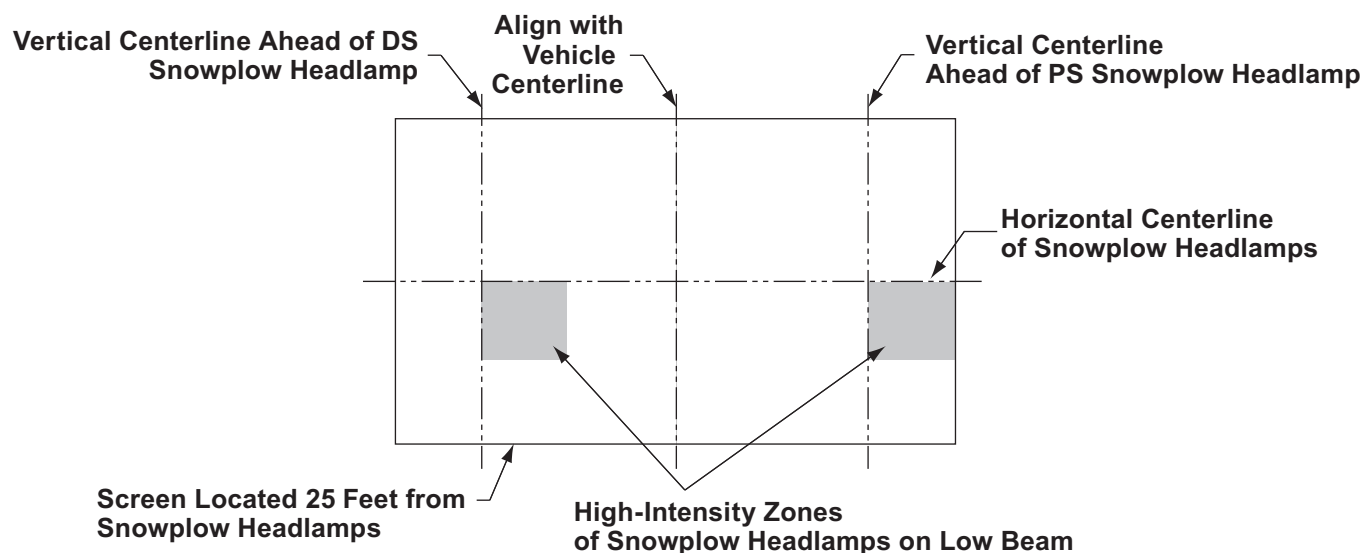

# MAINTENANCE

Maintenance	Periodically	Yearly
Check fasteners for tightness. Torque to specifications.	X	
Check hoses for wear and leaks.	X	
Check cylinders for leaks; inspect rod ends for corrosion and pitting.	X	
Lubricate all exposed cylinder rod ends with liquid white lithium grease to prevent corrosion.		X
Check cutting edges and plow shoes for wear. <i>NOTE: Do not discard plow shoe washers; these should be retained for different shoe adjustments.</i>	X	
Clean and lubricate all electrical plugs and connections with dielectric grease. Clean and install all dust caps prior to storing.	X	X
Lubricate all pins and bushings, inner slide box and A-frame latch with NLGI Grade 2 multipurpose lithium complex grease with molybdenum (MPGM) to maintain consistent operation.	X	X
Clean and paint all scratches or exposed metal with BLIZZARD® touch-up paint.	X	X
Check the hydraulic fluid level. Fill with fluid to 3/4" from the top of the reservoir. Do not exceed this level. Never mix different types of fluid.	X	
Remove and properly discard the fluid from the pump reservoir. Clean the pump filter and replace the hydraulic fluid to within 3/4" from the top of the reservoir. Changing the fluid annually will prolong the life of your pump and manifold. Never mix different types of hydraulic fluid.		X
Check the trip spring adjustment. Properly adjusted tension will allow a sheet of paper to pass between the 3rd and 4th coils of the spring.	X	
Adjust the wing spring as needed or install an optional second extension spring for increased return speed.	X	
Clean snow and ice build-up from the pump and manifold cover.	X	
Pressure wash and dry the entire snowplow prior to storing.		X
Cover the snowplow with a tarp if stored outside. This will protect your snowplow from sun fading and inclement weather, which can lead to accelerated corrosion.		X

## REMOVING SNOWPLOW FROM STORAGE

1. Perform all regular maintenance.
2. Replace the hydraulic fluid in the pump reservoir. Prolonged storage could result in condensation build-up.
3. Follow the mounting procedure on the POWER HITCH™ label.
4. Initiate all of the functions. Monitor the fluid level in the reservoir and fill to 3/4" from the top of the tank as necessary.
5. Adjust the snowplow headlamps as needed.

## LIFTING

To lift and move this snowplow, attach chain fall grab hooks to outside pivot beam area shown. Always follow recommended lift warnings and procedures. See following page for snowplow weights and dimensions.

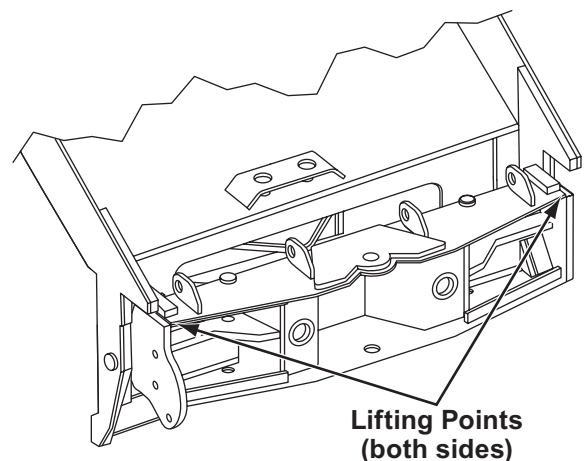

# TECHNICAL SPECIFICATIONS

Part	Specification	810	8611LP	8611
Moldboard	Length	96" (8')	102" (8'-6")	
	Thickness	12 ga		11 ga
	Height	31"		34"
	Reinforcement	4 Ribs @ 1/4"		
	Cutting Edge	1/2" x 6"		5/8" x 6"
	Finish	Powder Coat White		
	Trip Mechanism	(4) 3/8" Hooked Extension	(6) 3/8" Hooked Extension	
Wings	Length	12"	23"	
	Thickness	11 ga		7 ga
	Height	31"		34"
	Reinforcement	1 Rib @ 1/4"		
	Cutting Edge	1/4" x 10" T1		3/8" x 12-1/2" T1
	Finish	Powder Coat White		
A-Frame	Material	Rectangular Tube and Channel Type		
	Hitch Pins	3/4" x 6" Yellow Zinc		
	Finish	Powder Coat Black		
Pump	Construction	Steel Housing with Clear Plastic Tank		
	Type	Internal Gear Pump		
	Size	2.5 cc	3.1 cc	
	Motor	12V Starter		
	Weight	32 lb		
	Mount	A-Frame Install with Hex Cap Screws		
	Reservoir Capacity	2 qt		
	Controls	Toggle and Rocker Switch/Joystick or Touchpad		
Manifold	Construction	Red Anodized Aluminum	Black Anodized Aluminum	
	Valves	Electro-Hydraulic Cartridge		
Cylinders	<i>Angle Cylinders</i>	2		
	Stroke	10"	12"	
	Ram Diameter	1-3/4"	2"	
	Bore Diameter	2"	2-1/4"	
	<i>Raise/Lower Cylinders</i>	1		
	Stroke	4-5/8"		
	Ram Diameter	1-1/4"		
	Bore Diameter	3"	3-1/2"	
	<i>Slide Box Cylinders</i>	2		
	Stroke	13-15/16"	18-7/16"	
	Ram Diameter	1"	1-1/8"	
Bore Diameter	1-1/2"	1-3/4"		
Snowplow Headlamps	Type	Low-Profile with Turn Signals		
	Measurements	12"W x 5"H x 5-1/4"D		
	Housing	Plastic Composite		
	Bulb Type	High/Low Sealed Beam Halogen 12V Rectangular		
	Switch Type	Integrated ON/OFF Control Station Switch		
Snowplow Specs	Weight*	964 lb	1121 lb	1460 lb
	Amperage Draw**	155 A	175 A	
	Compact Width	96" (8')	102" (8'-6")	
	WIDE PASS™ Width	120" (10')	132" (11'-3")	
	BUCKET BLADE™ Width	111" (9'-3")	118" (9'-10")	
	Adjustable Plow Shoes	(2) Heavy-Duty Cast Steel		
	Mount Mechanism	Hydraulic Power Switch		
	Control Station	Rocker Switch/Joystick or Touchpad		

\* Weight does not include undercarriage.

\*\* Amperage Draw specifications are based on snowplow lift operation, at a shop temperature of 65°F, using BLIZZARD® Rapid Action Hydraulic Fluid. Amperage will vary with temperature, fluid viscosity and meter accuracy. Deadheading a plow function will result in significantly increased amperage.

## TROUBLESHOOTING

Problem	Cause	Solution
Pump will not run.	Snowplow harness may not be properly connected to the vehicle harness.	Verify that the harnesses are properly connected.
	Power or ground cables to the battery, pump or solenoid may not be properly connected.	Properly connect all cables. Clean and lubricate with dielectric grease. If power does not resume, check the continuity of all cables to find the break.
Pump will not run, power to the solenoid.	The black ground wire and brown/white activation wire on the solenoid are not properly connected.	Properly connect both cables. Test for power by initiating any joystick function except "FLOAT." <i>NOTE: The POWER rocker switch must be in the "ON" position to properly test any snowplow function.</i> If the solenoid is grounded and no power exists, diagnose the snowplow and truck harnesses.
Pump will not run with power to the solenoid. Brown/white activation wire and ground are properly connected.	The red, hot wire to the pump motor is not properly connected.	Connect red wire and check the black ground wire. If problem is not resolved, the solenoid could be inoperable or the pump motor may be worn. Replace the solenoid if there is no power to the pump. Replace the pump motor if it is receiving power.
Pump will not turn OFF. Do not allow the pump motor to run continuously. Unplug the harness until the solenoid can be tested or a BLIZZARD® outlet can diagnose the problem.	Solenoid may be damaged.	Disconnect the brown/white activation wire from the solenoid. If the problem is not resolved, replace the solenoid.
	Short in the control or wire harness.	Disconnect the control in the cab. If the pump turns OFF, there is a short in the electrical system.
Pump runs but snowplow functions are slow.	Fluid level in the pump reservoir is low. Fluid is leaking.	Add fluid to within 3/4" from the top of the tank. Check for leaks around the pump, manifold and cylinders.
	System pressure may be set too low. Increasing the pressure excessively will increase the amperage draw. This could damage the vehicle harness.	Adjust the pressure. Remove the hex cap on top of the pump and turn the screw clockwise. Proper system pressure should be set at 2400 psi. Test functions and repeat procedure as needed.
	Amperage from the vehicle's alternator is too low.	Repair or replace vehicle alternator. System amperage draw is 155 A (175 A for 8611) at 1500 psi.
	Pump filter may be clogged.	Remove the pump tank and thoroughly clean the filter.
A-frame latch will not move.	Draw latch is binding the A-frame latch.	Lower the draw latch to relieve binding on the A-frame latch and reposition the A-frame latch as needed.
Snowplow will not lift. Pump works properly.	Control station in the cab may not be properly connected.	Connect the power connector from the control to the vehicle harness.
	A-frame latch is in the (down) locked position.	Lift the A-frame latch into the raised position.
	Diode loop harness may be corroded or could have failed.	Clean diode loop harness thoroughly and/or replace.
	Coils on the manifold may be damaged.	Remove the S6 coil from the cartridge valve. Position a screwdriver inside the coil and push the draw latch connect/disconnect toggle switch upward. The screwdriver should be magnetically drawn to the coil. Replace coil if there is no action.
Snowplow will not lift with magnification to the S6 coil.	Hydraulic lock in the manifold. This occurs if the voltage is too low on the coils—should be 10 volts.	Loosen cartridge valve S6 to relieve pressure and retighten. DO NOT OVERTIGHTEN! Valves should be torqued to a maximum of 24 ft-lb.
	Solenoid cartridge valve may be contaminated.	Remove any foreign objects that may be obstructing proper valve operation. Replace if not operating properly after cleaning.

## TROUBLESHOOTING

Problem	Cause	Solution
Snowplow will not stay angled when plowing.	The angle pressure-relief valve is set too low. <i>NOTE: Increasing the pressure-relief setting will cause damage to your snowplow. Do not set the pressure relief greater than 3000 psi.</i>	Check the pressure relief by testing the valve inline with the cylinder. Attach a tee fitting to the angle cylinder hydraulic adapter and connect the hose and pressure gauge to the tee. <i>NOTE: The setting should not exceed 3000 psi.</i>
Snowplow will not angle, pump works.	Review all probable causes above.	<i>NOTE: Verify angle functions for coils S3 and S4.</i>
Wing will not stay angled when plowing.	The angle pressure-relief valve is set too low. <i>NOTE: Increasing the pressure-relief setting will cause damage to your snowplow. Do not set the pressure relief greater than 1700 psi (2650 psi for 8611).</i>	Test the wing pressure relief. Attach a fluid psi gauge to the quick-connect fitting on the manifold. The pressure relief should not be greater than 1700 psi (2650 psi for 8611).
Wing will not move, pump works.	Control station, harness or cables may be loose or improperly connected.	Verify that control station, harness and all cables are securely connected. Clean if necessary.
	Hydraulic lock in the manifold has occurred.	Loosen cartridge valves S9 and S10 or S1 and S2 to relieve pressure and retighten. <b>DO NOT OVERTIGHTEN!</b> Valves should be torqued to a maximum of 24 ft-lb.
	Power to the coils.	Verify that coils S1 and S2 (passenger-side slide box retract and extend) and S9 and S10 (driver-side slide box retract and extend) are grounded, connected properly and receiving power. If no power is available, diagnose the harness. Review the harness schematics. If power is present, review the next step.
	Coils are receiving power.	Verify that coils are magnetizing. Position a screwdriver inside of the coil. When the respective function is activated, the screwdriver is drawn to the side of the coil. If the coil is not drawn to the screwdriver, replace the coil. If power is present, review the next step.
Snowplow lowers too slowly.	Solenoid cartridge may be contaminated or damaged. A bent cartridge will not allow the valve to move freely inside of the cartridge.	Determine a damaged cartridge valve by reversing the driver-side and passenger-side cartridge valves. Replace valve if necessary.
	Variable flow control valve is not adjusted properly.	<b>⚠ WARNING: Snowplow can fall suddenly. You can die or be seriously injured. Drop snowplow to ground before adjusting flow control.</b> Turn flow control valve counterclockwise in small increments and test.
Snowplow drops sporadically.	Review all probable causes for "Snowplow will not lift."	Verify that S5 coil (float) or S5 and S8 coils (disconnect) for magnetism.
	Variable flow control valve is opened too far.	<b>⚠ WARNING: Snowplow can fall suddenly. You can die or be seriously injured. Drop snowplow to ground before adjusting flow control.</b> Turn clockwise 1/16 turn and test.
Headlamps will not switch from the vehicle to the snowplow.	No power or ground to the headlamp relay.	Verify that the headlamp/ground relay connector is connected. If the connector is properly attached, replace the headlamp relay(s).

# MOLDBOARD & WING PARTS — 810 & 8611 MODELS

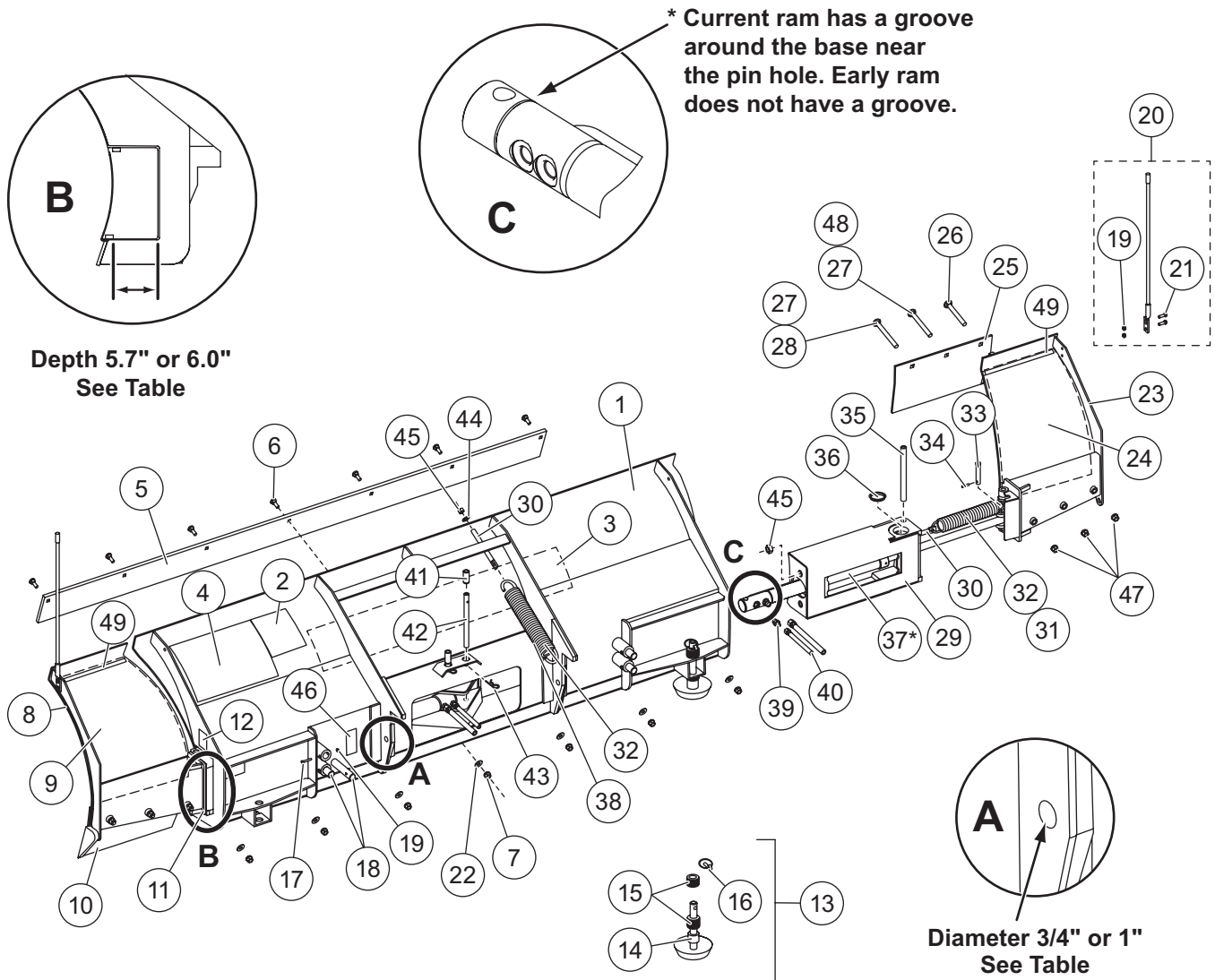

Item	Part	Qty		Description
		810	8611	
1	B52074-1	1	—	Moldboard
	B52085	—	1	Moldboard, 3/4" dia hole (See callout A.)
	B52185	—	1	Moldboard, 1" dia hole (See callout A.)
2	59900	1	1	Label – Information (Warning/Caution)
3	B63160	1	1	Label – POWER PLOW™ Center
4	44812	1	1	Label – POWER HITCH™ Attach/Detach
5	B61292	1	—	Moldboard Cutting Edge
	B52139	—	1	Moldboard Cutting Edge
6	90238	7	—	1/2-13 x 1-3/4 Carriage Bolt G8
	80238	—	7	5/8-11 x 2 Carriage Bolt G8
7	91335	13	—	1/2-13 Hex Locknut Topring GB
	91337	—	7	5/8-11 Hex Locknut Topring GB

G = Grade

## MOLDBOARD & WING PARTS — 810 & 8611 MODELS

Item	Part	Qty		Description
		810	8611	
8	B51042	1	–	Wing – DS
	B51100	–	1	Wing – DS
9	96325	1	–	Label, Wing – DS
	96329	–	1	Label, Wing – DS
10	B51048	1	–	Wing Cutting Edge (T1) – DS
	B51069	–	1	Wing Cutting Edge (T1) – DS
11	B50057	1	–	Slide Box – DS
	B50075	–	1	Slide Box – DS, 5.7" (See callout B.)
	B50095	–	1	Slide Box – DS, 6" (See callout B.)
12	29593	2	2	Label – Multiple Pinch Points
13	49071	2	2	HD Disc Shoe Assembly
14	60045	2	2	1-1/8 ID, 1-5/8 OD x 1-1/2 Spacer
15	91192	36	28	1" Flat Washer
16	93010	2	2	7/16 x 1-3/4 Linchpin
17	B61383	4	4	5/16-18 x 2-1/4 Hex Cap Screw G8
18	B61681	4	4	1 x 4-1/8 Slide Box Stop Pin
19	91332	8	8	5/16-18 Hex Locknut GB
20	B61049	1	1	Plow Guide Assembly (set of 2)
21	68494	4	4	5/16-18 x 1 Hex Cap Screw G5
22	90572	7	–	1/2 Hardened Flat Washer
	90576	–	7	5/8 Hardened Flat Washer
23	B51043	1	–	Wing – PS
	B51101	–	1	Wing – PS
24	96326	1	–	Label, Wing – PS
	96330	–	1	Label, Wing – PS
25	B51047	1	–	Wing Cutting Edge (T1) – PS
	B51070	–	1	Wing Cutting Edge (T1) – PS
26	B61418	2	–	1/2-13 x 3-1/2 Carriage Bolt G8
	B61360	–	2	1/2-13 x 5 Carriage Bolt G8
27	B61622	2	2	1/2-13 x 5-3/4 Carriage Bolt G8
28	B61362	–	2	1/2-13 x 6-1/2 Carriage Bolt G8
29	B50058	1	–	Slide Box – PS
	B50074	–	1	Slide Box – PS, 5.7" (See callout B.)
	B50094	–	1	Slide Box – PS, 6" (See callout B.)
30	B61416	6	8	5/8-11 x 7-3/8 Spade Bolt G8
31	B61398	2	–	13 OAL x 2 OD x 5/16 Extension Spring
32	23039	4	2	3/8 x 2-5/16 x 14-1/2 Blade Trip Spring
33	B61385	2	2	5/8 x 3.06 Clevis Pin
34	B61028	2	2	1/4 x 1-1/4 Spring Pin
35	B51009	2	–	3/4 x 9 Wing/Slide Box Pivot Pin
	B13307	–	2	1 x 11-1/8 Wing/Slide Box Pivot Pin
36	B61425	2	2	2-51/64 OD, 2-9/32 ID x 1/2 Plug, Black Polyurethane
37*	B60347	2	–	Slide Box Extend/Retract Hydraulic Cylinder (Early ram – see callout C.)
	43803	2	–	Ram Assembly 1-1/2 x 13-15/16 DA (Current ram - see callout C.)
	B60207	–	2	Slide Box Extend/Retract Hydraulic Cylinder (Early ram – see callout C.)
	43802	–	2	Ram Assembly 1-3/4 x 18-7/16 DA (Current ram - see callout C.)

G = Grade

## MOLDBOARD & WING PARTS — 810 & 8611 MODELS

Item	Part	Qty		Description
		810	8611	
38	B61099	–	6	3/8 x 2-3/8 x 14-1/2 Blade Trip Spring
39	B60007	4	–	Connector, Short –6 M JIC/–6 M ORB
	56695	–	4	Elbow, 45° –6 M JIC/–6 M ORB
40	49501	4	4	Hose, 3/8 x 36 w/F JIC Ends
41	B61198	2	2	5/8 x 1-1/8 Vinyl Cap, Black
42	B11989	2	2	5/8 x 11-1/2 Pin, Hydraulic Cylinder Base End
43	B61030	2	2	1/8 x 2-5/8 Hairpin Cotter
44	90576	4	6	5/8 Hardened Washer
45	91337	6	8	5/8-11 Hex Locknut GB
46	29256	1	1	Label – Foot Crush Hazard
47	B61365	–	6	1/2-13 Flanged Locknut
48	B61419	2	–	1/2-13 x 4-1/2 Carriage Bolt G8
49	50639	–	2	Wear Strip – Wing Top
G = Grade				



# MOLDBOARD & WING PARTS — 8611LP MODEL

\* Current ram has a groove around the base near the pin hole. Early ram does not have a groove.

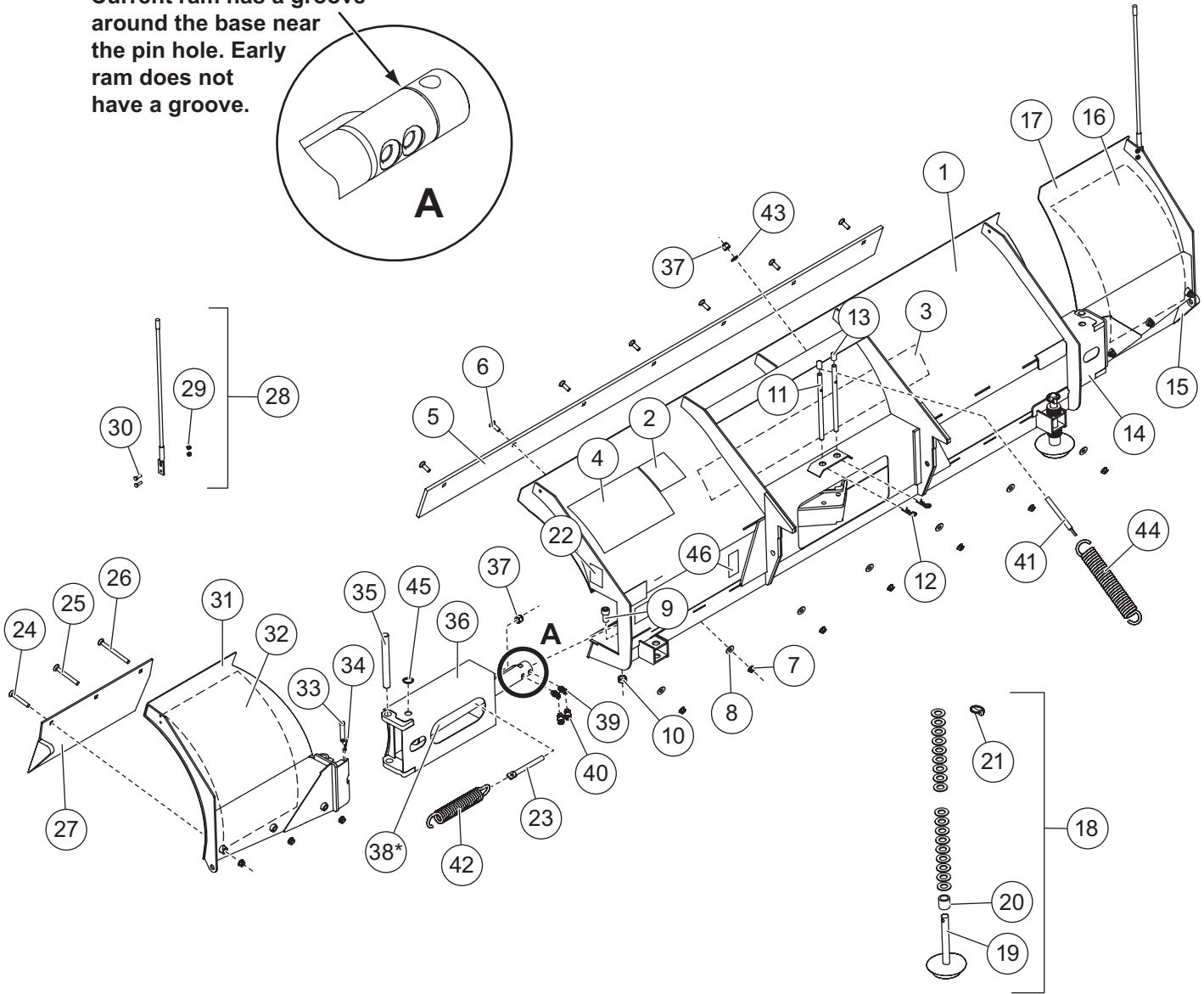
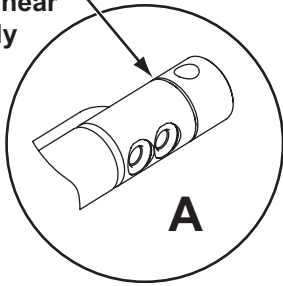

Item	Part	Qty	
		8611LP	Description
1	41174	1	Moldboard
2	59900	1	Label – Information (Warning)
3	B63160	1	Label – POWER PLOW™ Center
4	44812	1	Label – POWER HITCH™ Attach/Detach
5	B11962	1	1/2" Moldboard Cutting Edge (1080)
6	90238	7	1/2-13 x 1-3/4 Carriage Bolt G8
7	91335	13	1/2-13 Hex Locknut Topring GB
8	90572	7	1/2 Hardened Flat Washer
9	B61618	2	3/4-10 x 1-1/2 Screw
10	B61593	2	3/4-10 Hex Locknut
11	B11989	2	Slide Box Extend/Retract Pin
G = Grade			

## MOLDBOARD & WING PARTS — 8611LP MODEL

Item	Part	Qty	Description
		8611LP	
12	B61030	2	1/8 x 2-5/8 Hairpin Cotter
13	B61198	2	5/8 ID, 3/4 OD x 1 Vinyl Cap, Black
14	B55066	1	Slide Box – PS
15	B55007	1	Wing Cutting Edge – PS (T1)
16	96332	1	Label – PS wing
17	B55068	1	Wing – PS
18	49071	2	HD Disc Shoe Assembly
19	60045	2	1-1/8 ID, 1-5/8 OD x 1-1/2 Spacer
20	91192	52	1" Flat Washer
21	93010	2	7/16 x 1-3/4 Linchpin
22	29593	2	Label – Multiple Pinch Points
23	B61201	2	5/8-11 x 4-3/8 Spade Bolt
24	B61418	2	1/2-13 x 3-1/2 Carriage Bolt G8
25	B61419	2	1/2-13 x 4-1/2 Carriage Bolt G8
26	B61622	2	1/2-13 x 5-3/4 Carriage Bolt G8
27	B55006	1	Wing Cutting Edge – DS (T1)
28	B61049	1	Plow Guide Assembly (set of 2)
29	68494	4	5/16-18 x 1 Hex Cap Screw G5
30	91332	4	5/16-18 Hex Locknut
31	B55067	1	Wing – DS
32	96331	1	Label – DS Wing
33	B61385	2	5/8 x 3 Clevis Pin
34	90601	2	1/4 x 1-1/2 Cotter Pin
35	B55042	2	Wing Pivot Pin
36	B55065	1	Slide Box – DS
37	91337	8	5/8-11 Hex Locknut Type NE
38*	B60207	2	Slide Box Extend/Retract Hydraulic Cylinder (Early ram – see callout A.)
	43802	2	Ram Assembly 1-3/4 x 18-7/16 DA (Current ram - see callout A.)
39	56695	4	Elbow, 45° –6 M JIC/–6 M ORB
40	49501	4	Hose, 3/8 x 36 w/F JIC Ends
41	B61416	6	5/8-11 x 7-3/8 Spade Bolt G8
42	B61167	2	3/8 x 2-5/8 x 12-1/2 Extension Spring
43	90576	6	5/8 Hardened Washer
44	23039	6	15-1/4 OAL x 2-3/8 OD x 3/8 Extension Spring
45	B61425	2	2-51/64 OD, 2-9/32 ID x 1/2 Polyethylene Plug, Black
46	29256	1	Label – Foot Crush Hazard
G = Grade			

# A-FRAME & PIVOT BEAM PARTS — ALL MODELS

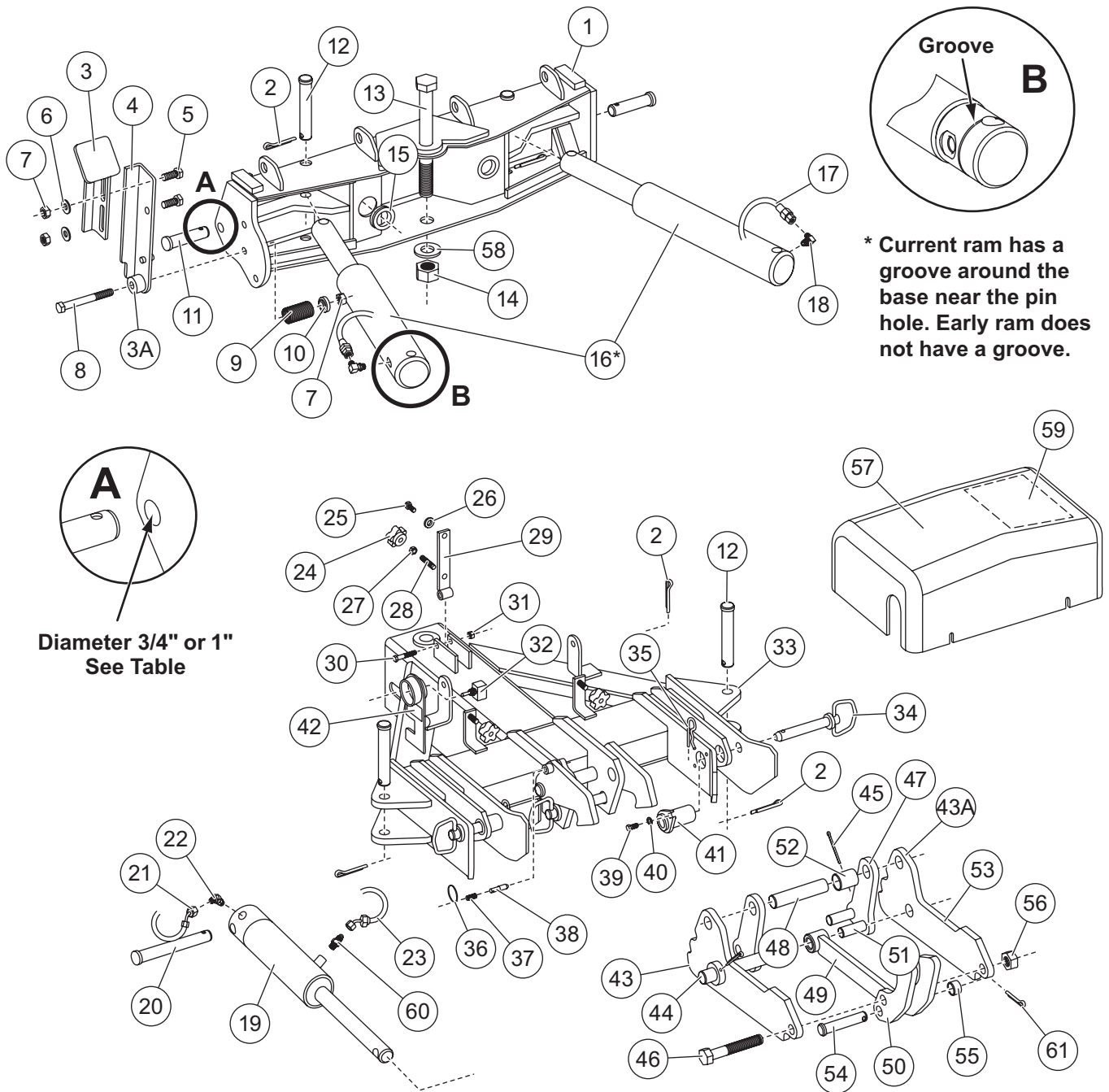

Item	Part	Qty			Description
		810	8611LP	8611	
1	B52151	1	—	—	Pivot Beam
	B55008	—	1	—	Pivot Beam
	B41052	—	—	1	Pivot Beam, 3/4" hole (see callout A) – requires B50069 Clevis Pin
	B41077	—	—	1	Pivot Beam, 1" hole (see callout A) – requires B61717 Clevis Pin
2	90601	8	8	8	1/4 x 1-1/2 Cotter Pin
3A	B41039	1	1	1	Kickstand Assembly (incl. items 3–10)
3	B41047	1	1	1	Kickstand Foot
		G = Grade			SS = Stainless Steel

## A-FRAME & PIVOT BEAM PARTS — ALL MODELS

Item	Part	Qty			Description
		810	8611LP	8611	
4	B41038	1	1	1	Kickstand Leg
5	90665	2	2	2	1/2-13 x 1-1/4 Hex Cap Screw G8
6	90572	2	2	2	1/2 Flat Hardened Washer
7	90593	3	3	3	1/2-13 Hex Locknut GC Distorted Thread
8	42009	1	1	1	1/2-13 x 4-1/2 Hex Cap Screw G8
9	B61293	1	1	1	1-1/8 OD x 53/64 ID x 2 Compression Spring
10	B41037	1	1	1	3/8 x 1-1/8 OD x 35/64 Stepped Bushing
11	B50069	2	2	2	3/4 x 3 Clevis Pin (for use with B41052 Pivot Beam)
	B61717	—	—	2	1" x 3-1/4" Clevis Pin (for use with B41077 Pivot Beam)
12	95739	4	4	4	3/4 x 5 Clevis Pin
13	B61330	1	1	1	1-8 x 9 Hex Cap Screw G8
14	B61008	1	1	1	1-8 Top Locknut GC Distorted Thread
15	B61217	4	4	4	1-1/2 ID, 2-1/8 OD 60 Durometer Grommet, Black Rubber
16*	B60029	2	—	—	Hydraulic Cylinder, Plow Angle (Early ram — see callout B.)
	43801	2	—	—	Ram Assembly 1-3/4 x 10 (Current ram — see callout B.)
	B60221	—	2	2	Hydraulic Cylinder, Plow Angle (Early ram — see callout B.)
	43804	—	2	2	Ram Assembly 2 x 12 (Current ram — see callout B.)
17	B60091	2	—	—	3/8 x 24 Hydraulic Hose, Plow Angle
	B60223	—	2	2	3/8 x 26 Hydraulic Hose, Plow Angle
18	56590	2	2	2	9/16-18 90° Adjustable Elbow Hydraulic Adapter ORB
19	B60255	1	—	—	Hydraulic Cylinder, Plow Raise/Lower
	B60237*	—	1	1	Hydraulic Cylinder, Plow Raise/Lower (Early ram — see callout B note.)
	43814*	—	1	1	Ram Assembly 3-1/2 x 4-5/8 DA (Current ram — see callout B note.)
20	B40124	1	1	1	3/4 x 6 Clevis Pin
21	B60273	1	1	1	Hose, 3/8 x 17 w/F JIC Ends
22	56695	1	1	1	Elbow, 45° —6 M JIC/—6 M ORB
23	B60274	1	1	1	Hose, 3/8 x 15 w/F JIC Ends
24	B61628	3	3	3	3/8-16 Clamping Knob SS
25	90097	2	2	2	3/8-16 x 3/4 Hex Cap Screw G8
26	29233	3	3	3	3/8 Hardened Washer
27	91333	1	1	1	3/8-16 Hex Locknut Topring G8
28	B61629	1	1	1	3/8-16 x 2-1/8 Threaded Stud
29	B40004	1	1	1	Pump Mount Hinge
30	90043	1	1	1	3/8-16 x 2 Hex Cap Screw G8
31	B61034	1	1	1	3/8-16 Top Locknut GC
32	B62038	1	1	1	Toggle Switch DPDT (ON-OFF-ON) Draw Latch Connect/Disconnect
33	B52152	1	—	—	A-Frame
	B40107	—	1	1	A-Frame
34	B61426	2	2	2	3/4 x 6 Hitch Pin
35	B61105	2	2	2	9/64 x 2-11/16 Hairpin Cotter
36	B61309	1	1	1	1.25 OD Standard Split Ring
37	B61000	1	1	1	0.94 OAL x 0.36 OD x .029 Wire Compression Spring SS
38	B40079	1	1	1	3/8 x 1-3/4 A-Frame Latch Pin SS
39	90671	2	2	2	5/16-18 x 3/4 Hex Cap Screw G8
40	B61412	2	2	2	5/16 Hardened Washer
41	B40088	2	2	2	A-Frame Pivot, Replaceable Bushing
42	B61295	1	1	1	Label — POWER HITCH™ Connect/Disconnect Switch (BLZ 1037)
43A	B40109	1	1	1	Draw Latch Assembly (incl. items 2, 43–56)
43	B40080	1	1	1	Outer Draw Latch Plate — DS
44	B40110	1	1	1	1 x 6-1/2 Draw Pin (13/64 cotter pin hole)

G = Grade

SS = Stainless Steel

## A-FRAME & PIVOT BEAM PARTS — ALL MODELS

Item	Part	Qty			Description
		810	8611LP	8611	
45	B61363	2	2	2	3/16 x 2-1/2 Cotter Pin
46	B61004	1	1	1	3/4-10 x 4-1/2 Hex Cap Screw G8
47	B40074	2	2	2	Inner Draw Latch Plate
48	B40070	1	1	1	1 x 4-21/32 Draw Latch Mount (to A-Frame) Pin
49	B40114	1	1	1	Draw Latch Arm
50	B40123	1	1	1	Draw Latch Finger
51	B40042	2	2	2	3/4 x 2-1/2 Draw Latch Arm Pivot Pin/Hydraulic Cylinder Rod End Pin
52	B40093	1	1	1	1-1/4 OD x 1-1/16 ID x 1-1/2 Bushing
53	B40081	1	1	1	Outer Draw Latch Plate – PS
54	66950	1	1	1	3/4 x 4 Clevis Pin
55	B40116	1	1	1	1 OD x 25/35 ID x 5/8 Spacer
56	B61006	1	1	1	3/4-10 Top Locknut GC
57	B40119	1	1	1	Pump/Manifold Cover, Black
58	B61203	1	1	1	1" Washer
59	B63100	1	1	1	Label – Hydraulic Hose Guide (BLZ 1055)
60	B60007	1	1	1	Connector, Short –6 M JIC/–6 M ORB
61	91911	1	1	1	5/32 x 1-1/2 Cotter Pin

G = Grade SS = Stainless Steel

# POWER UNIT PARTS — ALL MODELS

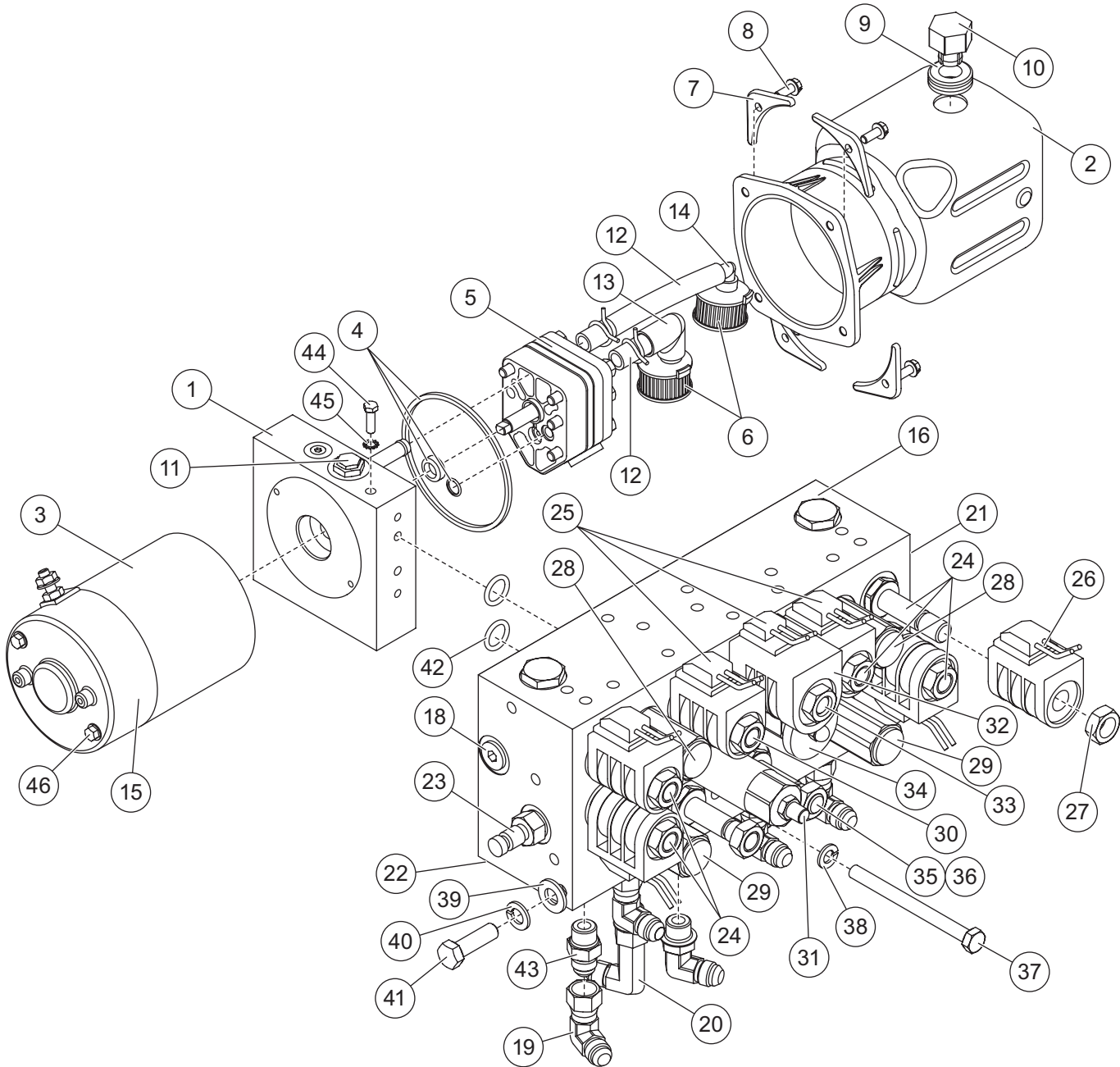

Item	Part	Qty			Description
		810	8611LP	8611	
1	B60402	1	—	—	Hydraulic Pump Assembly (incl. items 1, 2, 4–14)
	B60417	—	1	1	Hydraulic Pump Assembly (incl. items 1, 2, 4–14)
ns	B60375	1	—	—	Pump/Manifold Kit (incl. items 1, 16, 37, 38, B60275, B62039, B61016 [2], 91203 [2], 90055 [2], B61412 [2], 56805 [8])
ns	B60376	—	1	1	Pump/Manifold Kit (incl. items 1, 16, 37, 38, B60424, B62039, B61016 [2], 91203 [2], 90055 [2], B61412 [2], 56805 [8])
2	B60433	1	1	1	Reservoir
3	B60434	1	1	1	Motor, 12V DC
4	B60435	1	1	1	Seal Kit
5	B60436	1	—	—	Pump Assembly, 2.47cc/Rev
	B60446	—	1	1	Pump Assembly, 3.14cc/Rev
G = Grade					ns = not shown
					ga = gauge

## POWER UNIT PARTS — ALL MODELS

Item	Part	Qty			Description
		810	8611LP	8611	
6	B60437	2	2	2	Filter
7	B60438	4	4	4	Reservoir Clamp
8	B60439	4	4	4	Reservoir Screw
9	B60345	4	4	4	Grommet
10	B60346	1	1	1	Breather
11	B60440	1	1	1	Relief Valve Assembly
12	B60450	2	2	2	Tube, cut to length
13	B60442	1	1	1	Elbow
14	B60444	1	1	1	Elbow
15	B60445	1	1	1	Brush Kit
16	B60264	1	—	—	Manifold Assembly
	B60265	—	1	1	Manifold Assembly
18	B60050	3	3	3	–6 SAE Hollow Hex Plug
19	B60006	6	6	6	Elbow, Swivel 90° –6 M JIC/–6 F JIC Swivel
20	B60072	1	1	1	Elbow, Extra Long 90° –6 M JIC/–6 M ORB
21	B60228	2	2	2	Piston Assembly
22	B60225	4	4	4	Check Valve, 50 psi
23	B60173	1	1	1	7/16-20 ORB Test Port Coupling
24	B60166	5	5	5	Spool Valve, 3-Way, 2-Position
25	B62147	1	1	1	Coil Harness Assembly (incl. items 25 [7], 35, 31)
26	B62114	7	7	7	Coil, PDL10V DC
27	B60052	9	9	9	1/2-20 Hex Jam Nut
ns	B62045	1	1	1	Electric Connector, Male, Plastic
ns	B62096	19	19	19	Cable Seal, Silicone 18 ga, Orange
ns	B62116	1	1	1	Cavity Plug, Silicone 18–16 ga, White
ns	B62097	9	9	9	Terminal, Male 18–16 ga
ns	B62118	1	1	1	3/8 ID End Ring Terminal Copper, 6 ga
28	B60278	2	—	—	Relief Valve, 1700 psi
	B60226	—	2	2	Relief Valve, 2800 psi
29	B60279	2	—	—	Relief Valve, 1500 psi
	B60227	—	2	2	Relief Valve, 2650 psi
30	B60167	2	2	2	Spool Valve, 4-Way, 2-Position
31	B60168	1	1	1	Relief Valve, 3000 psi
32	B62115	1	1	1	DDL Coil 10V DC
33	B60170	1	1	1	Spool Valve, 3-Way, 2-Position
34	B60169	1	1	1	Flow Control Valve
35	B60475	1	1	1	Two-Way Valve NC
36	B62176	1	1	1	PDL Coil 12V DC, Delta (waterproof, with O-rings)
37	B61010	2	2	2	5/16-18 x 3-3/4 Hex Cap Screw G8
38	B61011	2	2	2	5/16 Split Lock Washer
39	29233	2	2	2	3/8 Hardened Washer
40	91203	2	2	2	3/8 Spring Lock Washer
41	90055	2	2	2	3/8-16 x 1-1/4 Hex Cap Screw G8
42	B60038	2	2	2	3/32 CSW, 9/16 ID, 3/4 OD O-Ring Neoprene
43	B60007	6	6	6	Connector, Short –6 M JIC/–6 M ORB
44	90097	1	1	1	3/8-16 x 3/4 Hex Cap Screw G5
45	B61307	1	1	1	3/8 Internal/External Tooth Lock Washer
46	B61716	2	2	2	1/4-20 x 6-1/4 Coarse Thread Hex Cap Screw G5
ns	56590	1	1	1	Elbow, 90° –6 M JIC/–6 M ORB

G = Grade

ns = not shown

ga = gauge

# HEADLAMPS & CONTROL PARTS — ALL MODELS

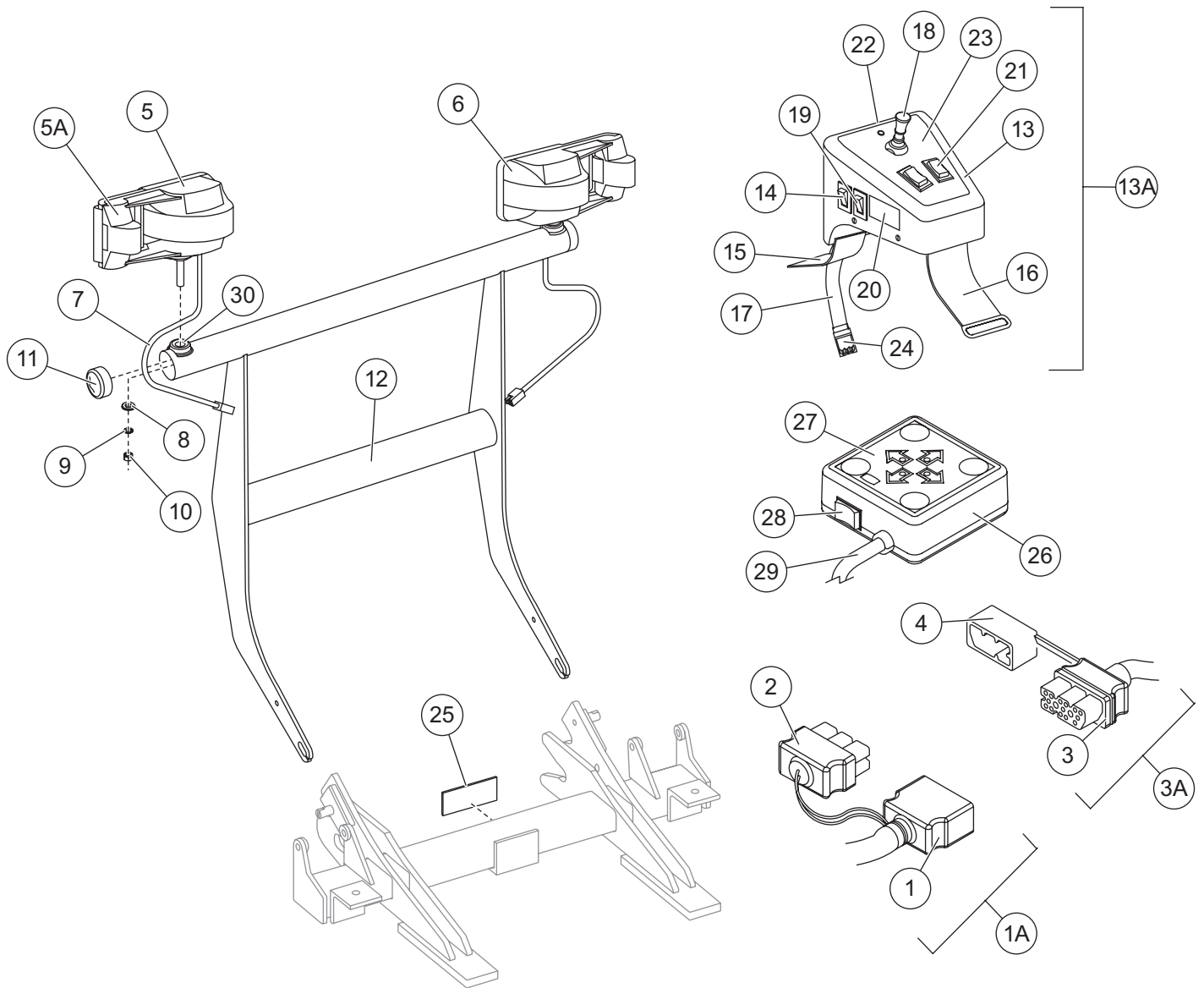

Item	Part	Qty			Description
		810	8611LP	8611	
1 A	B62039	1	1	1	Plow Harness Assembly (incl. items 1–2, B62046, B62093, B61439, B62167)
1	B62057	1	1	1	Snowplow Harness
2	B62001	1	1	1	Weather Cap, Rubber, Snowplow Side
ns	B62046	1	1	1	Electric Connector, Female, Plastic
ns	B62093	10	10	10	Female Terminal 18–16 ga
ns	B61439	2	2	2	Cable Tie, 15"
ns	B62167	1	1	1	Diode Loop Harness
3 A	B62215	1	1	1	Harness Assembly, Vehicle (incl. items 3 and 4, B61439, B62124, B62212, B62035, B62144, B62056, B62072, B62008, B62009, B62016, B61031)
3	B62150	1	1	1	Vehicle Harness
4	B62000	1	1	1	Weather Cap, Rubber – Vehicle Side
G = Grade					ns = not shown
					ga = gauge



## HEADLAMPS & CONTROL PARTS — ALL MODELS

Item	Part	Qty			Description
		810	8611LP	8611	
ns	B62124	1	1	1	1/4 x 1-1/4 BUSS ARC Fuse 15 A/32V
ns	B62212	1	1	1	Main Lighting Harness
ns	B62035	2	2	2	Weather Cap, Lighting Harness, Rubber
ns	B62144	4	4	4	Headlamp Relay, CB1-D-12V
ns	B62178	1	1	1	Heavy-Duty Motor Solenoid 12V DC – 225 A
ns	B62056	1	1	1	Power Contactor Ground Wire 24"
ns	B62072	4	4	4	End Ring Terminal 3/8 ID, Copper, 4 ga
ns	B62008	1	1	1	Fuse Clip, Mini
ns	B62009	1	1	1	Fuse Clip, Auto Blade
ns	B62016	4	4	4	Splice Lock Connector (18–14 WAG)
ns	B61031	3	3	3	#12-14 x 3/4 Hex Washer Self-Drilling Screw
5 A	B61106	1	1	1	Snowplow Headlamp Assembly (incl. items 5–10, B62061)
5	B62059	1	1	1	Headlamp – DS
6	B62060	1	1	1	Headlamp – PS
7	B62032	2	2	2	Harness (with 6-pin plug), Plow Headlamp Side
8	B61550	2	2	2	1/2 ID x 1 OD x .105 Washer, Neoprene Backing Galvanized
9	90651	2	2	2	7/16 External Tooth Lock Washer
10	B61111	2	2	2	7/16-14 Hex Nut G8
ns	B62108	2	2	2	Lighting Harness Repair Kit, Harness Side
ns	B62061	2	2	2	Headlamp Sealed Beam Halogen (H6545/H4666)
ns	56099	1	1	1	Corrosion Preventive Compound
11	B61427	2	2	2	2-1/4 ID, 2-25/64 OD x 3/4 Vinyl Cap, Black
12	B39032	1	1	–	Light Tower
	B39041	–	–	1	Light Tower
13 A	B62109	1	1	1	Rocker Switch/Joystick Control Station Assembly (incl. items 13–23, B61036, B62183, B62184)
13	B61296	1	1	1	Control Station Housing
14	B62065	1	1	1	Rocker Switch SPST (OFF-None-ON) 15 A/250V AC
15	B61126	1	1	1	Rocker Switch Control Box Housing Plate
16	B61127	1	1	1	61" Hook-and-Loop Fastener Strap with 2" Metal D-Ring Black
17	B62130	1	1	1	Electrical Connector (12-pin and 2-pin plugs)
18	B62177	1	1	1	Joystick Assembly Only
19	B62129	1	1	1	System ON/OFF Rocker Switch SPDT (ON-OFF-ON) 10 A/250V AC
20	B63098	1	1	1	Label – Snowplow Headlamps/Power Switch ON/OFF (BLZ 1053)
21	B62066	2	2	2	Rocker Switch, Wing Extend & Retract/Plow Angle
22	B61035	4	4	4	10-24 x 1/2 Pan-Head Machine Screw
23	B61169	1	1	1	Label – Joystick Control Station (BLZ 1028)
24	B62202	1	1	1	POWER PLOW™ Joystick Control Harness
ns	B61036	4	4	4	U-Clip, 10-24
ns	B62183	1	1	1	Circuit Board for POWER PLOW Joystick Control
ns	B62184	1	1	1	Timed Delay Joystick
25	B63161	–	–	–	Label – Push Beam, 2.25 x 9.75 (BLZ 1071)
	B63162	–	–	–	Label – Undercarriage Push Beam, 1.50 x 6.50 (BLZ 1072)
26	B62141	1	1	1	POWER PLOW Touchpad Control Station (incl. items 26–28)
27	B62194	1	1	1	Label – POWER PLOW Touchpad Control
28	B62193	1	1	1	PC Board for POWER PLOW Touchpad Control
29	B62200	1	1	1	Harness, POWER PLOW Touchpad Control
30	B61231	1	1	1	Headlamp Ball Stud Mount Adapter

G = Grade

ns = not shown

ga = gauge

## ACCESSORIES & KITS — ALL MODELS

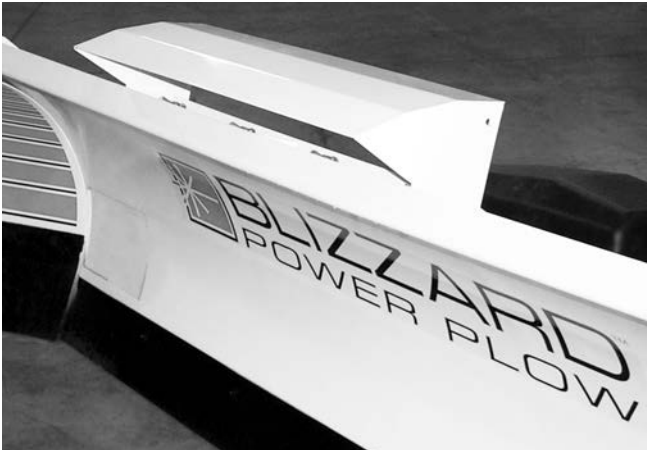

1. The snowplow airfoil helps channel air flow to your truck radiator during the long haul over the road. Mounted front and center, our custom airfoil redirects air over the top of the blade and into the grille of your vehicle. The airfoil is shipped with complete mounting hardware.



4. Beef up your POWER PLOW snowplow with our 3/8" thick wing cutting edges. These edges are built to withstand heavy snowplow use on the roughest road surfaces and also provide added material for protection against sidewalk curb wear. Mounting hardware included.



2. Rugged and durable, the 3/8" thick, 2-ply rubber snow deflector keeps snow off your windshield and in its place—on the ground! One-piece design allows for wing clearance and provides optimum snow deflection. The deflector is shipped with a POWER PLOW™ vinyl label and complete mounting hardware.
3. The **Emergency Parts Kit** includes the most common replacement parts: angle cylinder hose, lift cylinder hose, hitch pin with hairpin cotter, angle cylinder clevis pin with cotter, 90° angle cylinder fitting, solenoid, and more. The durable polyester bag (17" x 8-3/4" x 9-3/8") allows for easy storage behind or under your seat.



5. BLIZZARD® Rapid Action Hydraulic Fluid is specially formulated for use in BLIZZARD snowplows and can significantly enhance the operation and performance of the hydraulic system. BLIZZARD zinc-free hydraulic fluid maintains its viscosity to temperatures as low as -25°F. BLIZZARD hydraulic fluid is available by the quart, gallon or 55-gallon drum.

## ACCESSORIES & KITS — ALL MODELS



6. Our easy-to-install, adjustable pedestal mount kit will position either POWER PLOW™ snowplow control station how you want it. Ideal for bucket seat vehicles with low center consoles. Pedestal accessory shipped with complete hardware and adapter plate.

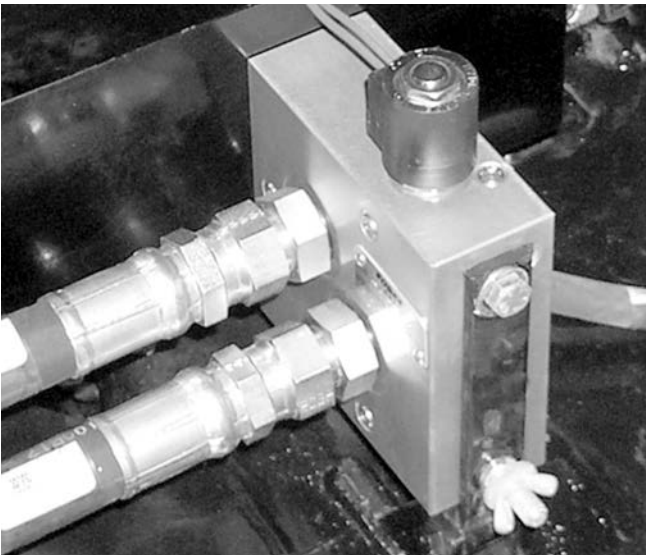

7. Experience increased power and speed in all of the snowplow hydraulic functions with this easily installed add-on central hydraulic valve block. The auxiliary manifold attaches right up to the existing manifold and pump bracket without any modifications needed. Provides up to 30 gpm input (4000 psi max.) from the vehicle pump and 2–3 gpm output (2500 psi max.) to the existing hydraulic manifold. Hydraulic hoses, fittings and pump not included.

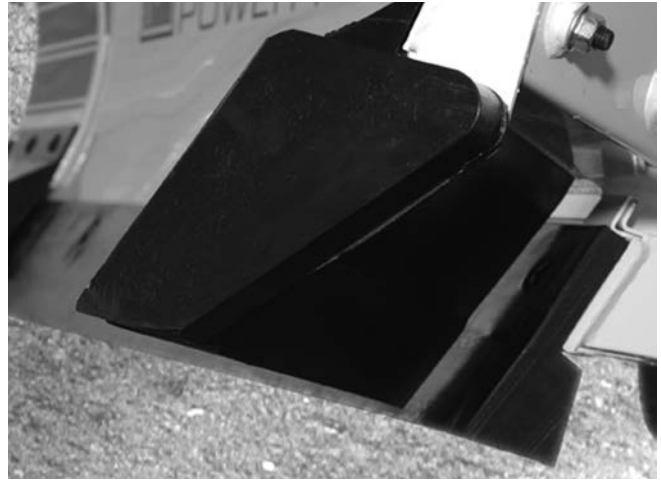

8. Durable and long lasting, the POWER PLOW™ polyurethane moldboard and wing cutting edges will keep you plowing longer and safer. Specially formulated for snow plowing applications, BLIZZARD® poly edges resist gouging, provide superior wear life and effectively reduce plowing noise. Ideal for all plowing conditions. Edges are shipped with mounting hardware.



9. Putting your snowplow away for the winter? Have a deep scratch to cover? Clean up your blade and snowplow parts with our gloss spray paints. BLIZZARD touch-up paint provides an excellent finish to help keep your snowplow looking its best. Paint provided in 12-oz spray cans.

## ACCESSORIES & KITS — ALL MODELS

10. Ballast (additional weight) is an important part of qualifying vehicles for snowplow eligibility. Rear ballast must be used when necessary to remain in compliance with axle ratings and ratios as specified by the vehicle manufacturer. If ballast is required, it is important that it be secured properly behind the rear axle. A ballast retainer kit is available from your BLIZZARD outlet.

**NOTE: The ballast retainer kit is for snowplow vehicles requiring ballast. See your BLIZZARD outlet for the correct amount of ballast required. Include the weight of the retainer as part of the ballast requirement. Sand bags are recommended for use as ballast.**

**NOTE: Ballast recommended and its weight calculations assume the entire width of the bed is filled as close to tailgate as possible.**

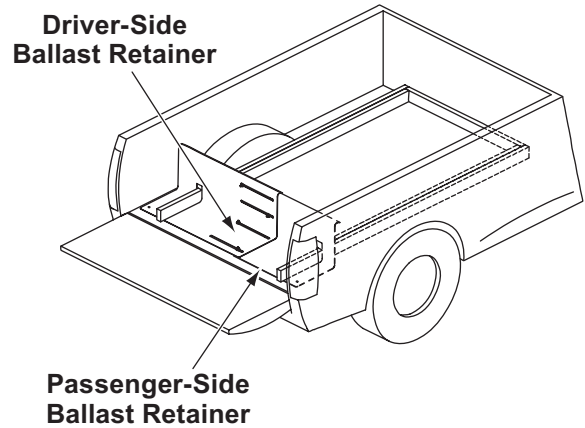

Accessories					
Item	Part	Qty			Description
		810	8611LP	8611	
1	B52093	1	–	–	Snowplow Airfoil
	B52092	–	1	1	Snowplow Airfoil
2	B61241	1	–	–	Rubber Snow Deflector with Hardware
	B52087	–	1	1	Rubber Snow Deflector with Hardware
3	50885	1	1	1	Emergency Parts Kit
4	B61288	1	–	–	3/8" Wing Cutting Edges with Hardware (T1) (set of 2)
	B51114	–	–	1	Extended Wear Wing Cutting Edges (set of 2)
5	B63070	–	–	–	BLIZZARD® Rapid Action Hydraulic Fluid (quart)
	B63072	1	1	1	BLIZZARD Rapid Action Hydraulic Fluid (gallon)
	B63091	1	1	1	BLIZZARD Rapid Action Hydraulic Fluid (drum – 55 gallons)
6	B63078	1	1	1	Pedestal Mount Kit
7	B60310	1	1	1	Central Hydraulic Valve Block
8	B61536	1	–	–	Polyurethane Moldboard and Wing Cutting Edges (with hardware)
9	B61219	1	1	1	POWER PLOW™ High Performance Spray Paint (12 oz), Gloss White
	B63073	1	1	1	POWER PLOW High Performance Spray Paint (12 oz), Gloss Black
10	62849	1	1	1	Ballast Retainer Kit
ns	B60133	1	1	1	Hydraulic Pressure Test Gauge Kit with Hose and Quick Disconnect

ns = not shown

## ACCESSORIES & KITS — ALL MODELS

		Kits			
Item	Part	Qty			Description
		810	8611LP	8611	
ns	B61352	1	–	–	POWER PLOW Hardware Kit, Model 810
ns	B61356	–	1	1	POWER PLOW Hardware Kit, Model 810
ns	B60275	1	–	–	Hydraulic Adapter Kit (incl B60005 [3], B60006 [6], B60007 [11], B60072, 56695)
ns	B60424	–	1	1	Hydraulic Adapter Kit (incl B60005 [3], B60006 [6], B60007 [7], B60072, 56695 [5])
ns	B60420	1	–	–	Hydraulic Hose Kit (incl B60273, B60274, 49501 [4], B60091 [2])
ns	B60421	–	1	1	Hydraulic Hose Kit (incl B60273, B60274, 49501 [4], B60223 [2])
ns	B61255	1	1	–	Hardware Kit, Moldboard Cutting Edge
ns	B61624	–	–	1	Hardware Kit, Moldboard Cutting Edge
ns	B52067	1	–	–	Moldboard Cutting Edge Kit with Hardware
ns	B52095	–	1	–	Moldboard Cutting Edge Kit with Hardware
ns	B61625	–	–	1	Moldboard Cutting Edge Kit with Hardware
ns	B61431	1	–	–	Hardware Kit, Wing Cutting Edge (set for 2 Wings)
ns	B51104	1	–	–	Wing Cutting Edges Kit with Hardware (1/4", set of 2)
ns	B61431	–	1	–	Hardware Kit, Wing Cutting Edge (set of 2)
ns	B61687	–	1	–	Wing Cutting Edges Kit with Hardware (set of 2)
ns	B61387	–	–	1	Hardware Kit, Wing Cutting Edge (set of 2)
ns	B51103	–	–	1	Wing Cutting Edges Kit with Hardware (3/8", set of 2)
ns	B62195	1	1	1	Headlamp Replacement Kit for B61106 (incl. Sealed Beam HP6545, Rim, Spacer Bumpers [4], Screws [4])
ns	B62196	1	1	1	Turn Signal Replacement Kit for Headlamp B61106 (incl. Lamp 1157, Turn Signal Lens, Lens Gasket, Screws [2])
ns	B60360	1	–	–	Combo Seal Kit, Cylinder B60029/B60065
ns	43792	1	–	–	Seal Kit, Ram Assembly 43801, 43813
ns	B60365	–	1	1	Combo Seal Kit, Cylinder B60207
ns	43793	–	1	1	Seal Kit, Ram Assembly 43802
ns	B60366	–	1	1	Combo Seal Kit, Cylinder B60221/B60324
ns	43795	–	1	1	Seal Kit, Ram Assembly 43804, 43805
ns	B60369	–	1	1	Combo Seal Kit, Cylinder B60237
ns	B60371	1	–	–	Combo Seal Kit, Cylinder B60255
ns	B60373	1	–	–	Combo Seal Kit, Cylinder B60347
ns	43794	1	–	–	Seal Kit, Ram Assembly 43803
ns	96027	1	–	–	Moldboard Label Pack
ns	96033	–	1	–	Moldboard Label Pack
ns	96031	–	–	1	Moldboard Label Pack

ns = not shown



Blizzard  
PO Box 245038  
Milwaukee, WI 53224-9538  
[www.blizzardplows.com](http://www.blizzardplows.com)

 A DIVISION OF DOUGLAS DYNAMICS, LLC



Copyright © 2014 Douglas Dynamics, LLC. All rights reserved. This material may not be reproduced or copied, in whole or in part, in any printed, mechanical, electronic, film or other distribution and storage media, without the written consent of Blizzard. Authorization to photocopy items for internal or personal use by Blizzard outlets or snowplow owner is granted.

Blizzard reserves the right under its product improvement policy to change construction or design details and furnish equipment when so altered without reference to illustrations or specifications used. Blizzard or the vehicle manufacturer may require or recommend optional equipment for snow removal. Do not exceed vehicle ratings with a snowplow. This product is manufactured under the following U.S. patents: 5,638,618; 5,899,007; 6,178,669; 6,253,470; 6,276,076; 6,393,737; 6,408,549; 6,412,199; 6,442,877; 6,615,513; 7,134,227; 7,430,821; CAN patents 2,184,922; 2,229,783; 2,259,508; 2,358,145; 2,358,354; 2,466,195; and other patents pending. Blizzard offers a limited warranty for all snowplows and accessories. See separately printed page for this important information. The following are registered (®) or unregistered (™) trademarks of Douglas Dynamics, LLC: BLIZZARD®, BLIZZARD POWER PLOW®, BUCKET BLADE™, POWER PLOW™, POWER HITCH™, WIDE PASS™.

Printed in U.S.A.