

PARTS & INSTALLATION INSTRUCTIONS MEYER SNOW PLOW MOUNTING FOR 1989 TOYOTA 4 x 4 PICKUP

IMPORTANT NOTICE

End user must be given this instruction sheet prior to delivery of this snow plow.

The equipment you have purchased should only be used on vehicles equipped with the manufacturer's snow plow preparation packages. Snow plowing without the original snow plow preparation package may damage your vehicle and the added weight of the equipment may impair the operation and control of the vehicle. Snow plowing with a vehicle that the manufacturer does not recommend for that purpose may void your new vehicle warranty. If your vehicle is not originally equipped with the snow plow preparation package, additional parts may be necessary before snow plowing. Owners of these vehicles should consult their dealers before purchase or installation of such parts. **CAUTION:** The installation, on any vehicle, of these parts is not a full substitute for the original equipment snow plow preparation package. **WARNING:** Lift arm extends beyond bumper of vehicle. To minimize damage from a front-end collision. Lift arm should be removed from vehicle when snow plow is not in use.

PARTS LIST

Item	Part No.	Qty.	Description
	18050	1	MOUNTING CARTON - (18049 Less P.A.F.)
1	11447	1	● Mounting Angle, L.H.
2	11448	1	● Mounting Angle, R.H.
3	11220	1	● Lift Frame
4	11226	2	● Strap
5	11225	1	● Clevis Frame
6	11137	2	● Light Bracket
7	11293	2	● Light Brace
8	10529	1	● Support Arm
9	10514	1	● Lift Arm
10	12984	1	● Pivot Bar
11	12978	2	● Trip Spring
12	13594	1	● A-Frame
	08587	1	● HARDWARE BAG - MTG.
13	20066	6	● Bolt H 3/8-16 x 1-1/4" Gr. 5
14	20094	2	● Bolt H 1/2-13 x 1-1/4" Gr. 5
15	20096	4	● Bolt H 1/2-13 x 1-3/4" Gr. 5
16	20140	4	● Bolt H 5/8-11 x 1-3/4"
17	20144	1	● Bolt H 5/8-11 x 2-3/4"
18	20147	1	● Bolt H 5/8-11 x 3-1/2"
19	21988	6	● Bolts H 12mm x 1.25 x 30mm Gr. 8.8
20	22110	2	● Bolts H 12mm x 1.25 x 110mm Gr. 8.8
21	20355	6	● Flatwasher, 1/2
22	20327	4	● Lockwasher, 3/8
23	21991	8	● Lockwasher, 12mm
24	20305	2	● Locknut, 3/8-16
25	20307	6	● Locknut, 1/2-13
26	20309	6	● Locknut, 5/8-11
27	11101	2	● Quick Disconnect Pin
28	21984	2	● Hair Pin Cotter
	08511	1	● SNOW PLOW HARDWARE BAG
29	11006	2	● Hinge Pin
30	21984	2	● Hair Pin Cotters
31	12150	2	● Eye Bolts
32	20318	4	● Nuts, Eslock 5/8-11
33	13598	2	● Pivot Bolts
34	13591	1	● King Bolt
35	20150	2	● Bolts H 5/8-11 x 4-1/2" Gr. 5
36	20309	5	● Locknuts, 5/8-11
	09916	1	● SNOW PLOW MARKER KIT
37		2	● Snow Plow Marker Assys.
38		2	● Clamps
39		2	● Bolts H 1/4-20 x 1"
40		2	● Locknuts 1/4-20
41		2	● Lockwasher, 1/4
	09102	1	MOLDBOARD ASSEMBLY - TM-6.5
43	09100	1	● Cutting Edge - TM-6.5
44	21943	6	● Bolts C 1/2-13 x 1-3/4"
45	20307	6	● Locknuts 1/2-13

Parts indented are included in the carton, bag or assembly under which they are indented. When ordering parts furnish Part No., Name and Description. Also furnish Vehicle Model and Year. Type of Hydraulic Unit and Moldboard Size.

Meyer Products, reserves the right, under its continuing product improvement program, to change construction or design details, specifications and prices without notice or without incurring any obligation.

GENERAL INFORMATION

CAUTION: Always disconnect battery before beginning installation.

DO NOT burn holes or weld vehicle frame. This may cause frame failure.



After first use retighten all mounting bolt connections to specified torque. All mounting bolt connections to be checked periodically for tightness.

Check contents against the parts list to determine all are correct and included; and also to familiarize yourself with them.

Locknuts are furnished. Do not tighten bolts and nuts until installation is complete (unless otherwise specified), then be sure to tighten all attaching parts per specified torque chart.

NOTE: It is important that the Meyer Electro-Touch Harness and Meyer Snow Plow Light Harness and all other electrical wires be routed around hot or moving engine parts, and any sharp sheet metal. Protection must be provided to guard against wire damage at these points. All excess or loose wire must be neatly secured using wire ties.

TORQUE CHART FOOT LBS.

Bolt Nut Size	GR. 2 	GR. 5 or 8.8 Metric 	GR. 8 
1/4 - 20	4 - 5		
5/16 - 18	9 - 11		
3/8 - 16	17 - 20	26 - 29	
7/16 - 14		42 - 46	60 - 66
1/2 - 13 (12mm)		64 - 72	90 - 100
5/8 - 11		127 - 141	179 - 198
3/4 - 10		227 - 251	

INSTALLATION INSTRUCTIONS

- Remove Tow Hooks and Splash Pan. They will not be used. Bumper will remain on vehicle.
- Attach Mounting Angles (1 & 2) to vehicle frame using 12mm x 30mm Bolt (19), 1/2 Flatwasher (21) and 12mm Lockwasher (23). Leave slightly loose so Mounting Angles (1 & 2) can move.
- Attach Lift frame (3) and Straps (4) to Mounting Angles (1 & 2) using 1/2 x 1-3/4" Bolts (15) and 1/2 Locknuts (25). Install 1/2 x 1-1/4" Bolts (14) and 1/2 Locknuts (25) in rear hole of Mounting Angles (1 & 2) and Lift Frame (3).
- Remove the outer suspension bolt and nut from each side of vehicle cross member. Save the nuts for reuse. Place Clevis Frame (5) in position and attach to Straps using 5/8 x 1-3/4" Bolts (16) and 5/8 Locknuts (26). Attach rear of Clevis Frame (5) to vehicle cross-member using 12mm x 110mm Bolts (20), 12mm Lockwashers (23) and original vehicle nuts.
- Tighten all fasteners as shown in torque chart beginning with those securing Mounting Angles (1 & 2) to Lift Frame (3) and Straps (4).

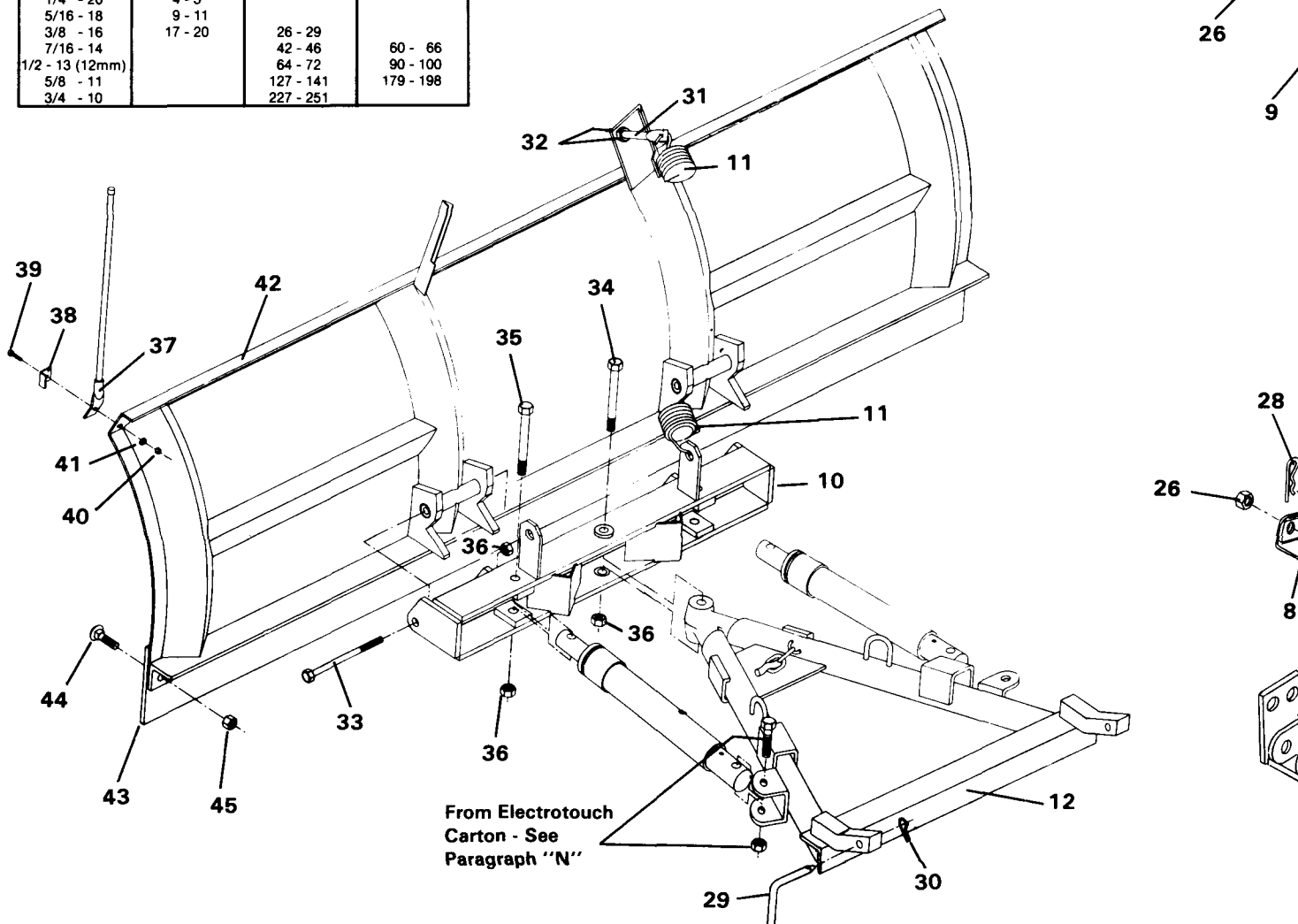

NOTICE: Meyer Products assumes no responsibility for installations not made in accordance with these instructions.

- F. Attach Light Brackets (6) to Weld Nuts in Lift Frame (3) using 3/8 x 1-1/4" Bolts (13) and 3/8 Lockwashers (22). Assemble Light Brace (7) to Light Bracket (6) using 3/8 x 1-1/4" Bolts (13). Using Light Brace (7) as a template, drill a 7/16" hole through Lift Frame (3) side plate. Attach using 3/8 x 1-1/4" Bolts (13) and Locknuts (24). Attach snow plow lights to Brackets (6 & 7). Before tightening bolts, make certain vehicle hood will clear back of snow plow lights. Adjust as needed and tighten all fasteners.
- G. Snow Plow Lights must be adjusted to comply with Federal Regulations.
- H. Install plow light wiring per separate instructions.
- I. Assemble Electro-Touch Unit to support arm (8) with 5/8 x 3-1/2" Bolt (18) and lift arm (9) using 5/8 x 2-3/4" Bolt (17) and 5/8 Locknuts (26). Install on Lift Frame (3) using quick disconnect pin (27) and hair pin cotter (28).
- J. Install Hydraulic and Electrical system per separate instructions.
- K. Attach pivot bar (10) to moldboard (42) using pivot bolts (33) coated with chassis lubricant, and 5/8" locknut (36).

- L. Attach trip springs (11) to pivot bar (10) and moldboard (42) with eye bolts (31) and locknuts (32). Flat end of eye bolt (31) must be in a vertical position, as shown in Figure 1, to hinge properly when moldboard (42) trips. Proper tension is attained when trip spring (11) coils begin to separate and then tightening top locknut (32) four additional turns. Tighten bottom locknut (32) to secure eye bolt (31) in position. See Fig. 1.
- M. Assemble A-frame (12) to pivot bar (10) using king bolt (34) and 5/8" locknut (36). Grease king bolt (34) prior to installation.
- N. Install Power-Angling Rams with fitting end to the A-frame (12). Clevis using 5/8 x 3-1/4" bolt and 5/8" locknut (packed in hardware bag 08363 in Electro-Touch carton). Attach piston end of ram to pivot bar (10) using 5/8 x 4-1/2" bolt (35) and 5/8" locknut (36).
- O. Straighten end of plow markers (37) so they will be vertical after installation. Attach using 1/4" x 1" bolt (39) clamp (38), 1/4" locknut (40), and lockwasher (41).
- P. Secure the Moldboard-Pivot Bar-A-Frame assembly to vehicle at Clevis Frame (5) using quick pins (29) and cotters (30). Attach lift chain to lift arm (9) allowing sufficient slack to allow moldboard to follow ground contours.

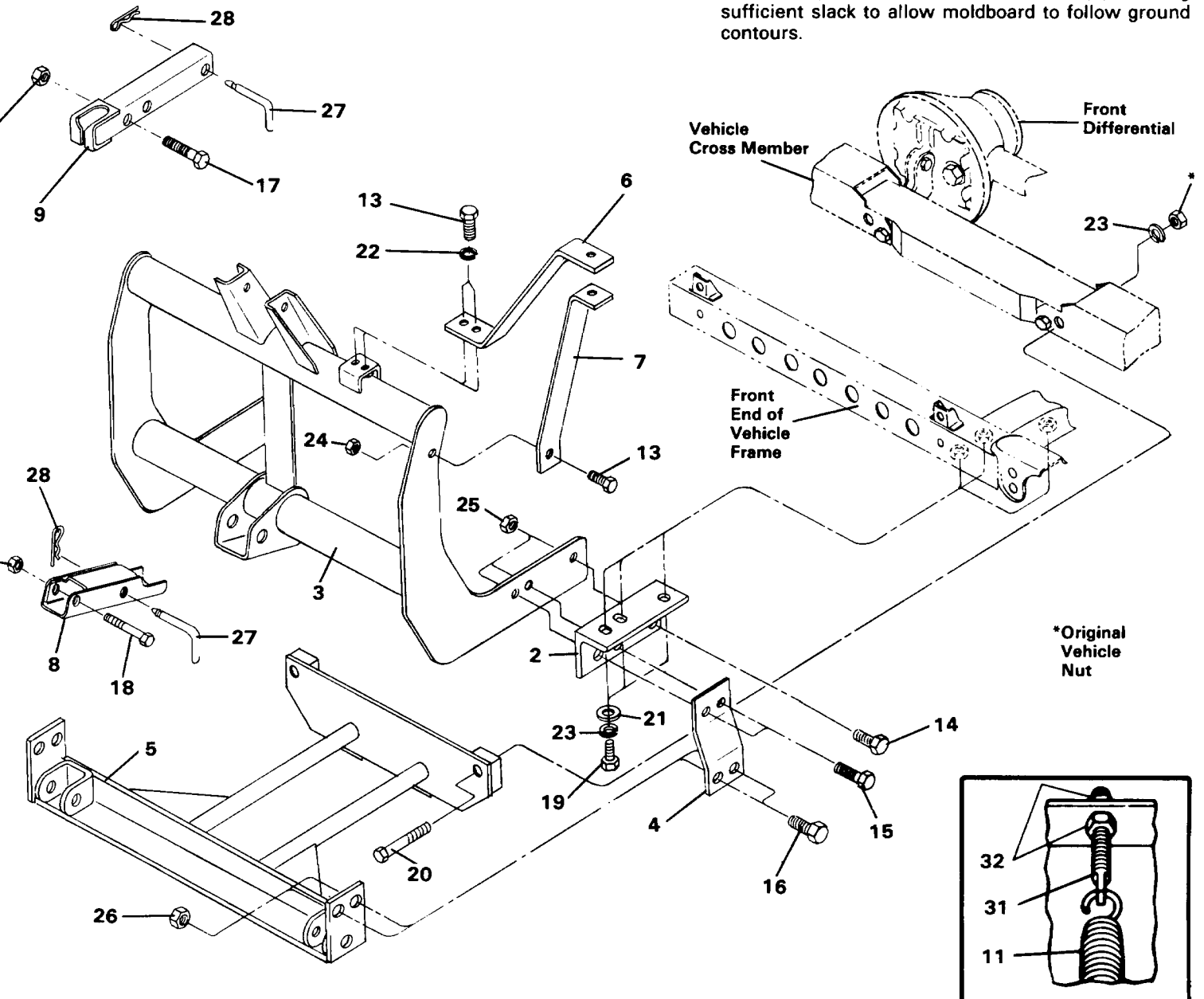

FIGURE 1