

## PARTS & INSTALLATION INSTRUCTIONS MEYER SNOW PLOW MOUNTING 1988 thru 1994 TOYOTA PICKUP 4X4 MODELS

### IMPORTANT NOTICE

**End user must be given this instruction sheet prior to delivery of this Snow Plow.**

The equipment you have just purchased should only be used on vehicles equipped with the Manufacturer's Snow Plow Preparation Packages. Snow Plowing without the original Snow Plow Preparation Package may damage your vehicle and the added weight to the equipment may impair the operation and control of the vehicle. Snow Plowing with a vehicle that the manufacturer does not recommend for that purpose may void your new vehicle warranty. If your vehicle is not originally equipped with the Snow Plow Package, additional parts may be necessary before snow plowing. Owners of these vehicles should consult their dealers before purchase or installation of such parts. CAUTION: the installation, on any vehicle, of these parts is not a full substitute for the original equipment Snow Plow Preparation Package.

**Warning: Lift Arm extends beyond bumper of vehicle. To minimize damage from a front-end collision, Lift Arm should be removed from vehicle when Snow Plow is removed.**

### PARTS LIST

ITEM	PART NO.	QTY.	DESCRIPTION
	18075	1	<b>MOUNTING CARTON</b>
1	11505	1	• Clevis Frame
2	11496	1	• Mounting Angle R.H
3	11497	1	• Mounting Angle L.H .
4	11462	2	• Receiver Tube Caps
5	10514	1	• Lift Arm
6	12978	1	• Trip Springs
7	12984	1	• Pivot Bar
8	13594	1	• AFrame
9	11275	1	<b>LIFT FRAME (Tubular)</b>
	08663	1	• <b>MOUNTING HARDWARE BAG</b>
10	11006	2	•• Hinge Pin
11	11368	2	•• Bracket: Light Extension
12	20095	8	•• Bolt H 1/2-13 x 1-1/2" Gr . 5
13	20144	1	•• Bolt H 5/8-11 x 2-3/4" Gr . 5
14	20146	2	•• Bolt H 5/8-11 x 3-1/4" Gr . 5
15	20307	8	•• Locknut 1 /2-13
16	20309	3	•• Locknut 5/8-11
17	20355	12	•• Flatwasher 1/2
18	21984	2	•• Hair Pin Cotter
19	21988	6	•• Bolt M 12mm 1 .25 x 30mm
20	22138	2	•• Bolt M 12mm 1 .25 x 40mm
21	21991	8	•• Lockwasher 12mm
22	22110	2	•• Bolt M 12mm 1 .25 x 110mm

**Parts indented are included in the carton, bag or assembly under which they are indented.**

Meyer Products and Diamond Equipment reserves the right, under its continuing product improvement program, to change construction or design details, specifications and prices without notice or without incurring any obligation.

Meyer Products  
18513 Euclid Ave. • Cleveland, Ohio 44112-1084  
Phone 486-1313 (Area Code 216)  
• email warranty@meyerproducts.com

# GENERAL INFORMATION

**CAUTION:** Always disconnect battery before beginning installation.

**DO NOT BURN** holes or **WELD** vehicle frame. This may cause frame failure.

After first use, retighten all mounting bolt connections to specified torque. All mounting bolt connections to be checked periodically for tightness.

Locknuts are furnished **DO NOT** tighten bolts and nuts until installation is complete (unless otherwise specified), then be sure to tighten all attaching parts per specified torque chart.

**NOTE:** It is important that the Meyer harness, all wires from the Meyer light switch, and all other electrical wires be routed around hot or moving engine parts, and any sharp metal. Protection must be provided to guard against wire damage at these points. All excess or loose wires must be neatly secured using wire ties.

Check contents against the parts list to determine all are correct and included, and also to familiarize yourself with them.

**SAFETY PRECAUTIONS** should be used when **Hydraulic Unit is in OPERATION** and plow is in a **RAISED** position. **Lower plow to ground when vehicle is PARKED.**

**OVERHAUL** and **SERVICE INFORMATION** are covered on separate instructions.

Follow these instructions explicitly. Warranty does not apply to a Meyer product which has been negligently or improperly assembled or installed.

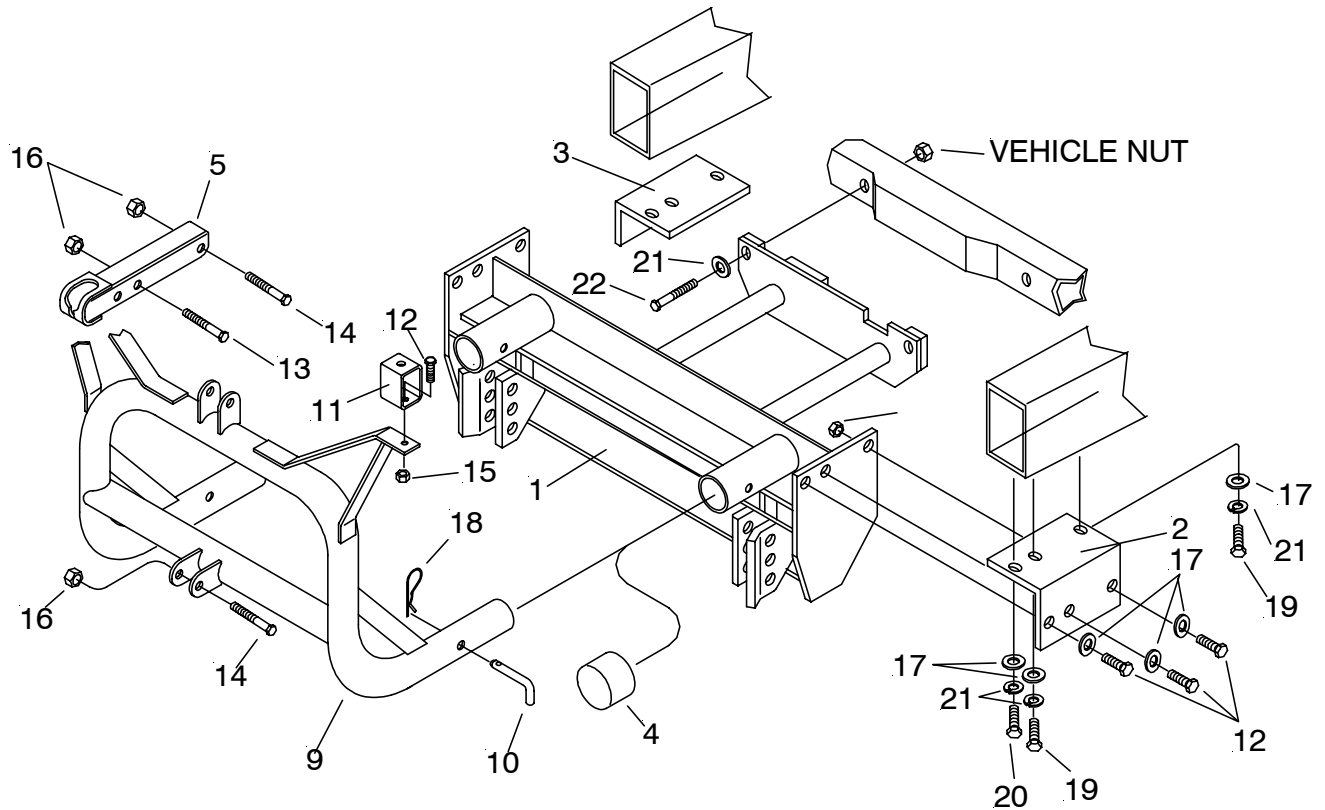

# INSTALLATION INSTRUCTIONS

- A. Remove Tow Hooks and Splash Pan. They will not be used. Bumper will remain on vehicle.
- B. Attach Mounting Angles (2 & 3) to vehicle frame using 12mm 1 .25 x 40mm Bolt (20), 12mm 1 .25 x 30mm Bolt (19), 1/2 Flatwasher (17), and 12mm Lockwasher (21). Leave slightly loose so Mounting Angles (2 & 3) can move.
- C. Attach Clevis Frame (1) to Mounting Angles (2 & 3) using 1/2 x 1-1/2" Bolts (12), Flatwashers (17), and 1/2 Locknuts (15) .
- D. Remove the outer suspension bolt and nut from each side of vehicle cross member. Save the nuts for re-use. Attach rear of clevis frame (1) to vehicle cross member using 12mm x 110mm Bolts (22), 12mm Lockwashers (21), and original vehicle nuts.
- E. Tighten all fasteners as shown in torque chart beginning with those securing Mounting Angles (2 & 3) to Clevis Frame (1).
- F. Install lift frame (9) into the tubes on the clevis frame (1) using hinge pin (10) and hairpin cotter (18) .



**Note: Before installing lift frame tubing to clevis frame, liberally coat ends of lift frame with chassis grease/anti-seize lubricant.**

- G. Install lights making certain there is clearance behind the lights for opening the vehicle hood. Lights must be aimed to comply with Federal Regulations .
- H. Install plow light wiring per separate instructions .
- I. Attach lift arm (5) to lift frame (9) using 5/8-11 x 3-1 /4" bolt (14) and locknut (161). Mount E-47 unit to lift frame with 5/8-11 x3-1/4"bolt (14) and locknut (16), and to lift arm (5) using 5/8-11 x 2-3/4" bolt (13) and locknut (16).
- J. Install Electro-Touch wiring system per separate instructions.
- K. Install Moldboard Assembly per separate instructions.

**Reference Forms 1-694 or 1-670.**

**Note: When the lift frame module (9) is removed from the vehicle, the insides of clevis frame (1) receiver tubes and outside ends of the lift frame should be coated with chassis grease/anti-seize lubricant and the protective receiver tube caps (4) installed over the clevis frame receiver tubes.**

## TORQUE CHART FOOT LBS.

Bolt Nut Size	Gr.  2	Gr.  5	Gr.  8
1/4 - 20	4 - 5		
5/16 - 18	9 - 11		
3/8 - 16	17 - 20		
7/16 - 14		26 - 29	
1/2 - 13		42 - 46	60 - 66
5/8 - 11		127 - 141	179 - 198
3/4 - 10		227 - 251	

**Meyer Products assumes no responsibility for installations not made in accordance with these instructions.**