



PARTS & INSTALLATION INSTRUCTIONS

1997 & Later TOYOTA Hi-Lux

4 x 4 Vehicles

IMPORTANT NOTICE

End user must be given this instruction sheet prior to delivery of this Snow Plow.

The equipment you have just purchased should only be used on vehicles equipped with the Manufacturer's Snow Plow Preparation Packages. Snow Plowing without the original Snow Plow Preparation Package may damage your vehicle and the added weight to the equipment may impair the operation and control of the vehicle. Snow Plowing with a vehicle that the manufacturer does not recommend for that purpose may void your new vehicle warranty. If your vehicle is not originally equipped with the Snow Plow Package, additional parts may be necessary before snow plowing. Owners of these vehicles should consult their dealers before purchase or installation of such parts. CAUTION: the installation, on any vehicle, of these parts is not a full substitute for the original equipment Snow Plow Preparation Package.

Warning: Lift Arm extends beyond bumper of vehicle. To minimize damage from a front-end collision, Lift Arm should be removed from vehicle when Snow Plow is removed.

Mounting Carton L/PAF 18091 / Mounting Carton W/PAF 18092DP

Parts List

Item	Part No.	PartNo.	Qty.	Description
	18091	18092DP	1	Mounting Carton
1	11915	11915	1	• Clevis Frame
2	10514	10514	1	• Lift Arm
	-----	12978	2	• Trip Spring
	-----	12959	1	• Pivot Bar
	-----	13778	1	• A-Frame Tubular
3	11462	11462	2	• Receiver Tube Cap-TM
	08747	08747	1	Hardware Bag
4	11006	11006	2	• Hinge Pin
5	22138	22138	2	• Bolt H M12 x 1.25 x 40mm Gr.8.8
6	22076	22076	2	• Bolt H M12 x 1.25 x 100mm Gr.8.8
7	20144	20144	1	• Bolt H 5/8-11 x 2-3/4" Gr. 5
8	20146	20146	2	• Bolt H 5/8-11 x 3-1/4" Gr. 5
9	20309	20309	3	• Locknut 5/8-11
10	20355	20355	6	• Flatwasher 1/2"
11	21984	21984	2	• Hair Pin Cotter
	08626	08626	1	• Kit: Light Elevation
12	11368	11368	2	•• Bracket
13	20095	20095	2	•• Bolt 1/2-13 x 1-1/2" Gr. 5
14	20307	20307	2	•• Locknut Esna 1/2-13
	-----	08156	1	• Snow Plow Hardware Bag
	-----	08852	1	• Marker Kit
15	11275	11275	1	Lift Frame

Parts indented are included in the assembly under which they are indented.

Meyer Products reserves the right, under its continuing product improvement program, to change construction or design details, specifications and prices without notice or without incurring any obligation.

Meyer Products LLC
18513 Euclid Ave. • Cleveland, Ohio 44112-1084
Phone 486-1313 (Area Code 216)
www.meyerproducts.com • email info@meyerproducts.com



Meyer Products LLC
6 Angell Lane • Damariscotta, ME 04543-4507
Phone 563-2227 (Area Code 207)
www.meyerproducts.com • email info@meyerproducts.com

GENERAL INFORMATION

CAUTION: Always disconnect battery before beginning installation.

DO NOT BURN holes or **WELD** vehicle frame. This may cause frame failure.

After first use, retighten all mounting bolt connections to specified torque. All mounting bolt connections to be checked periodically for tightness.

Locknuts are furnished **DO NOT** tighten bolts and nuts until installation is complete (unless otherwise specified), then be sure to tighten all attaching parts per specified torque chart.

Follow these instructions explicitly. Warranty does not apply to a Meyer product which has been negligently or improperly assembled or installed.

NOTE: It is important that the Meyer harness, all wires from the Meyer light switch, and all other electrical wires be routed around hot or moving engine parts, and any sharp metal. Protection must be provided to guard against wire damage at these points. All excess or loose wires must be neatly secured using wire ties.

Check contents against the parts list to determine all are correct and included, and also to familiarize yourself with them.

SAFETY PRECAUTIONS should be used when **Hydraulic Unit is in OPERATION** and plow is in a **RAISED** position. **Lower plow to ground when vehicle is PARKED.**

OVERHAUL and **SERVICE INFORMATION** are covered on separate instructions.

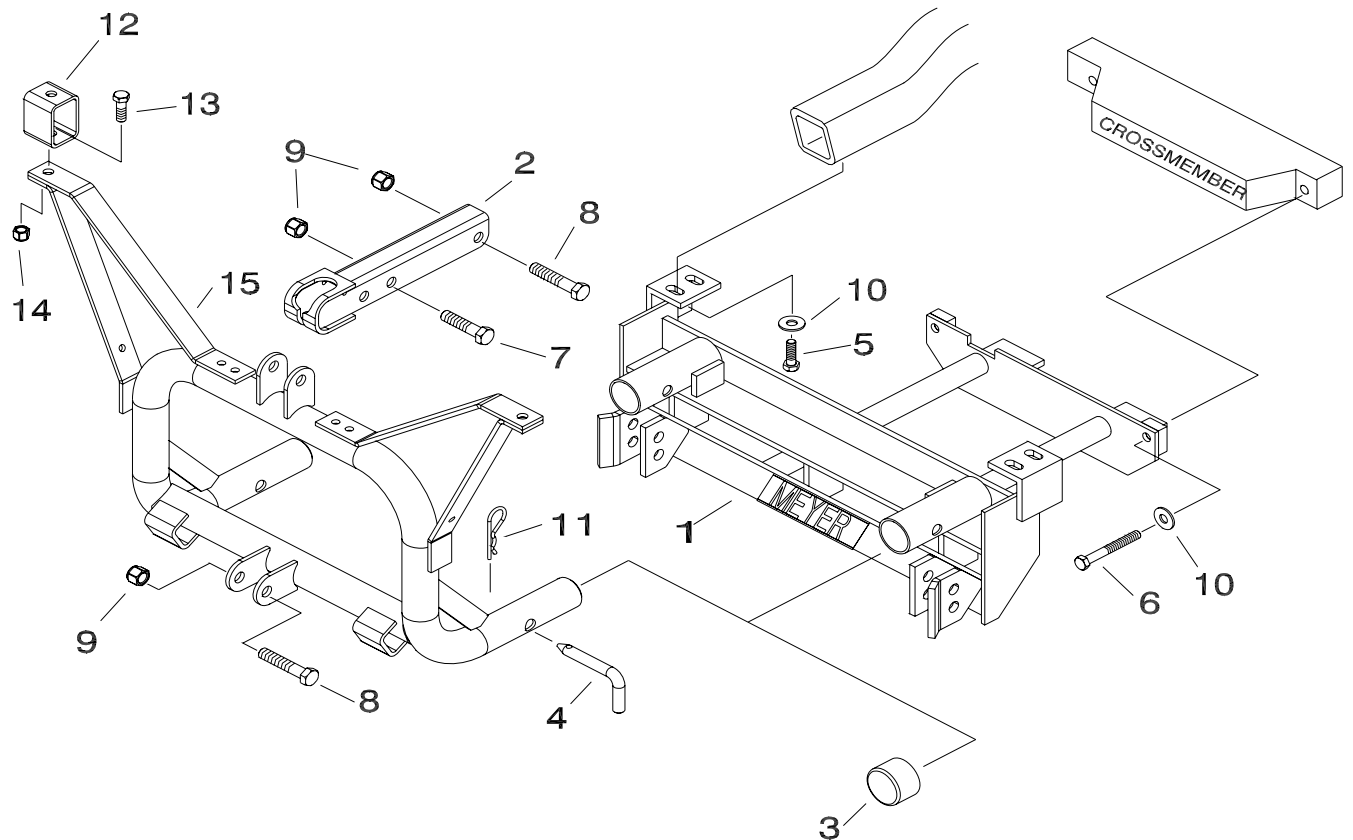

INSTALLATION INSTRUCTIONS



- A. Remove splash shield under the vehicle's front end by removing four bolts with a 12 mm socket. Retain, the splash shield and hardware they will not be reinstalled.
- B. Remove the passenger side towhook and driver side clip from under the front frame rails with a 17 mm socket. Retain the driver side bolts, they will be reused later in the install. Retain the passenger side bolts, towhook, and the DS clip they will not be reused.
- C. Remove the outermost bolt on both sides of the vehicle crossmember with a 17 mm socket. Retain all hardware, the two bolts will not be reused, nut and washer will be reused.
- D. Position Clevis Frame (1) under the front of the frame and align the upper slots to where the bolts were removed in step B. Attach Clevis Frame on the PS using two M12 x 1.25 x 40 mm bolts (5), and 1/2" flatwashers (10). Attach the DS using the two bolts that were retained in step B, and 1/2" flatwashers (10). Do not tighten at this time.
- E. Attach the two rear holes in Clevis Frame (1) to the vehicle cross member where bolts in step C were removed using M12 x 1.25 x 100 mm bolts (6), 1/2" flatwashers (10), and original nuts and washers retained from step C.
- F. Push Clevis back and tighten all fasteners to their proper torque. Tighten bolts in the same order they were assembled to the vehicle.
- H. Secure Lift Frame (15) to Clevis Frame using Hinge Pin (4) and Hair Pin Cotter (11).
- I. Attach lift arm (2) to lift frame (15) using 5/8-11 x 3-1/4 bolt (8) and locknut (9). Mount Hydraulic unit to lift frame using 5/ 8-11 x 3-1/4 bolt (8) and locknut (9), and to lift arm (2) using 5/8-11 x 2-3/4 bolt (7) and lock nut (9). **(SEE LIFT ARM WARNING)**
- J. Install Light Extensions (12) Part No. 08626 using 1/2-13 x 1-1/2 bolt (13) and locknut (14).
- K. Install hydraulic system and snow plow lights per separate instructions.
- L. Pre-Assemble Snow Plow Assembly, A-frame and Pivot Bar per sperate instructions.
- M. Attach the A-Frame chain to the Lift Arm (2) allowing sufficient slack to enable the Snow Plow to follow ground contour while plowing.

Note: When the lift frame module (15) is removed from the vehicle, the insides of the clevis frame (1) receiver tubes and outside ends of the lift frame should be coated with chassis grease / anti-seize lubricant and the protective receiver tube caps (3)

Note: Before installing lift frame tubing to clevis frame, liberally coat ends of lift frame with chassis grease anti-seize lubricant.

- G. Install Lift Frame (15) into the tubes on t h e Clevis Frame.

TORQUE CHART FOOT LBS.

Bolt Nut Size	Gr. 	Gr. 	Gr. 
1/4 - 20	4 - 5		
5/16 - 18	9 - 11		
3/8 - 16	17 - 20	26 - 29	
7/16 - 14		42 - 46	60 - 66
1/2 - 13		64 - 72	90 - 100
5/8 - 11		127 - 141	179 - 198
3/4 - 10		227 - 251	

Meyer Products assumes no responsibility for installations not made in accordance with these instructions.

4. Summary

The snowplough retaining device to be fitted onto N1 category vehicles, the specimen presented and tested, and the further types presented as per the documentation, are compliant in terms of design and safety.

The salt spreader retaining device to be fitted onto N1 category vehicles, the specimen presented and tested, and the further types presented as per the documentation, are compliant in terms of design and safety.

The snowplough retaining devices can be installed onto motor vehicles of the following types:

Car type	Meyer Classic	Type Cod Year
Toyota Hilux (since 2005)	18092	2005-2009
Toyota Hilux (1997-2005)	18091	1997-2005
Mitsubishi L200 (1987-2006)	18090	1997-2005
Nissan NP 300 (1998-2005)	18111	1998-2005
Ford Ranger (since 1998-2006)	18099/1811	1999-
Mazda B2500 (1998-2006)	18099/1811	1993-
Jeep Wrangler TJ (1997-2006)	18080	1997-
Jeep Wrangler JK (since 2007)	18119	2007-
Land Rover Deffender (1990-1994)	18096	1990-1994

Installation of the snowplough retaining device leaves the width and length of the vehicle unchanged.