



PARTS & INSTALLATION INSTRUCTIONS

1993 & Later MITSUBISHI PAJERO

4 x 4 Vehicles

IMPORTANT NOTICE

End user must be given this instruction sheet prior to delivery of this Snow Plow.

The equipment you have just purchased should only be used on vehicles equipped with the Manufacturer's Snow Plow Preparation Packages. Snow Plowing without the original Snow Plow Preparation Package may damage your vehicle and the added weight to the equipment may impair the operation and control of the vehicle. Snow Plowing with a vehicle that the manufacturer does not recommend for that purpose may void your new vehicle warranty. If your vehicle is not originally equipped with the Snow Plow Package, additional parts may be necessary before snow plowing. Owners of these vehicles should consult their dealers before purchase or installation of such parts. CAUTION: the installation, on any vehicle, of these parts is not a full substitute for the original equipment Snow Plow Preparation Package.

Warning: Lift Arm extends beyond bumper of vehicle. To minimize damage from a front-end collision, Lift Arm should be removed from vehicle when Snow Plow is removed.

Mounting Carton L/PAF 18093 / Mounting Carton W/PAF 18094DP

Parts List

Item	Part No.	PartNo.	Qty.	Description
	18093	18094DP	1	Mounting Carton
1	11920	11920	1	• Clevis Frame Weldment
2	10514	10514	1	• Lift Arm
	-----	12978	2	• Trip Spring
	-----	12959	1	• Pivot Bar
	-----	13778	1	• A-Frame Tubular
3	11462	11462	2	• Receiver Tube Cap-TM
	08748	08748	1	Hardware Bag
4	11006	11006	2	• Hinge Pin
5	20144	20144	1	• Bolt H 5/8-11 x 2-3/4" Gr. 5
6	20146	20146	2	• Bolt H 5/8-11 x 3-1/4" Gr. 5
7	20309	20309	3	• Locknut 5/8-11
8	20357	20357	2	• Flatwasher 5/8"
9	21984	21984	2	• Hair Pin Cotter
	08626	08626	1	Kit: Light Elevation
10	11368	11368	2	• Bracket
11	20095	20095	2	• Bolt 1/2-13 x 1-1/2" Gr. 5
12	20307	20307	2	• Locknut Esna 1/2-13
	-----	08156	1	• Snow Plow Hardware Bag
	-----	08852	1	• Marker Kit
13	11275	11275	1	Lift Frame

Parts indented are included in the assembly under which they are indented.

Meyer Products reserves the right, under its continuing product improvement program, to change construction or design details, specifications and prices without notice or without incurring any obligation.

Meyer Products LLC
18513 Euclid Ave. • Cleveland, Ohio 44112-1084
Phone 486-1313 (Area Code 216)
www.meyerproducts.com • email info@meyerproducts.com



Meyer Products LLC
6 Angell Lane • Damariscotta, ME 04543-4507
Phone 563-2227 (Area Code 207)
www.meyerproducts.com • email info@meyerproducts.com

GENERAL INFORMATION

CAUTION: Always disconnect battery before beginning installation.

DO NOT BURN holes or **WELD** vehicle frame. This may cause frame failure.

After first use, re-tighten all mounting bolt connections to specified torque. All mounting bolt connections to be checked periodically for tightness.

Locknuts are furnished **DO NOT** tighten bolts and nuts until installation is complete (unless otherwise specified), then be sure to tighten all attaching parts per specified torque chart.

Follow these instructions explicitly. Warranty does not apply to a Meyer product which has been negligently or improperly assembled or installed.

NOTE: It is important that the Meyer harness, all wires from the Meyer light switch, and all other electrical wires be routed around hot or moving engine parts, and any sharp metal. Protection must be provided to guard against wire damage at these points. All excess or loose wires must be neatly secured using wire ties.

Check contents against the parts list to determine all are correct and included, and also to familiarize yourself with them.

SAFETY PRECAUTIONS should be used when **Hydraulic Unit is in OPERATION** and plow is in a **RAISED** position. **Lower plow to ground when vehicle is PARKED.**

OVERHAUL and **SERVICE INFORMATION** are covered on separate instructions.

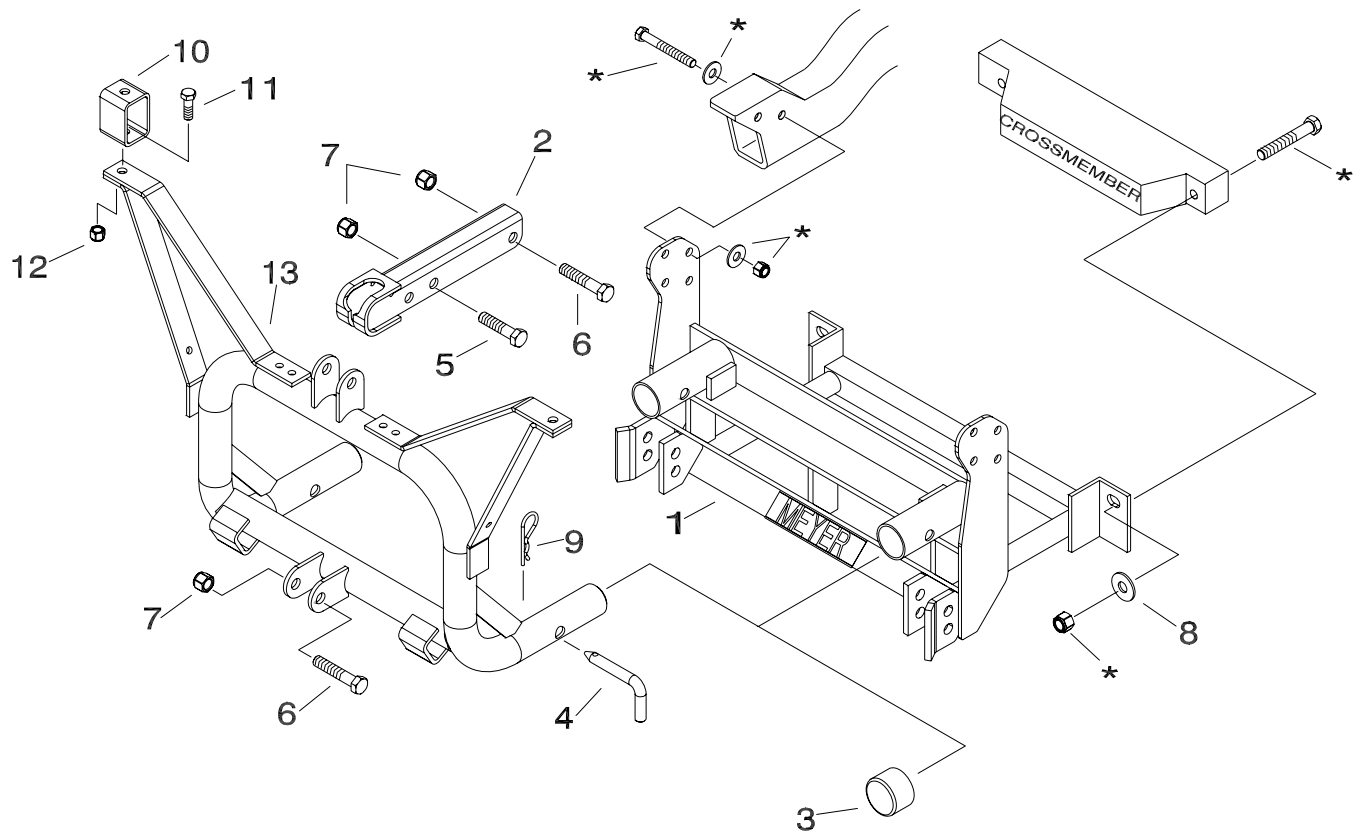

* Denotes original vehicle hardware.



INSTALLATION INSTRUCTIONS

- A. Remove front splash shield under the vehicle's front end by removing two bolts in the front with a 14mm socket and two in the rear with a 12mm socket. Replace the rear bolts to re-support the front of the rear splash shield. Retain, the front splash shield and hardware will not be reinstalled.
- B. Remove the two nuts/washers on the upper inside of the frame on each side. Retain this hardware it will be reused later in the install. Pound the bolts out until they are flush with the inside of the frame. This will be helpful later in the install.
- C. Remove the outermost nuts/washers on the vehicle crossmember on each side. Retain this hardware it will be reused later in the install.
- D. Position Clevis Frame (1) under the front of the frame and align the rear holes to the bolts protruding from the crossmember. Attach on both sides using the nuts retained in step C and 5/8" flatwashers (8) per illustration. Do not tighten at this time.
- E. Align two of the four side plate holes on Clevis Frame (1) to where the nuts/washers were removed in step B. **Note: Depending on the year vehicle either the bottom two hole or the top two holes will be used on each side.** Attach using the nuts/washers that were retained in step B. Do not tighten at this time.
- F. Push Clevis back and tighten all fasteners to their proper torque. Tighten bolts in the same order they were assembled to the vehicle.
- G. Install Lift Frame (13) into the tubes on the Clevis Frame.
- H. Secure Lift Frame (13) to Clevis Frame using Hinge Pin (4) and Hair Pin Cotter (9).
- I. Attach lift arm (2) to lift frame (13) using 5/8-11 x 3-1/4 bolt (6) and locknut (7). Mount Hydraulic unit to lift frame using 5/ 8-11 x 3-1/4 bolt (6) and locknut (7), and to lift arm (2) using 5/8-11 x 2-3/4 bolt (5) and lock nut (7). **(SEE LIFT ARM WARNING)**
- J. Install Light Extensions (10) Part No. 08626 using 1/2-13 x 1-1/2 bolt (11) and locknut (12).
- K. Install hydraulic system and snow plow lights per separate instructions.
- L. Pre-Assemble Snow Plow Assembly, A-frame and Pivot Bar per sperate instructions.
- M. Attach the A-Frame chain to the Lift Arm (2) allowing sufficient slack to enable the Snow Plow to follow ground contour while plowing.

Note: When the lift frame module (13) is removed from the vehicle, the insides of the clevis frame (1) receiver tubes and outside ends of the lift frame should be coated with chassis grease / anti-seize lubricant and the protective receiver tube caps (3)

Note: Before installing lift frame tubing to clevis frame, liberally coat ends of lift frame with chassis grease anti-seize lubricant.

TORQUE CHART FOOT LBS.

Bolt Nut Size	Gr. 2 	Gr. 5 	Gr. 8 
1/4 - 20	4 - 5		
5/16 - 18	9 - 11		
3/8 - 16	17 - 20	26 - 29	
7/16 - 14		42 - 46	60 - 66
1/2 -13		64 - 72	90 - 100
5/8 - 11		127 - 141	179 - 198
3/4 - 10		227 - 251	

Meyer Products assumes no responsibility for installations not made in accordance with these instructions.