



Mitsubishi FG Peculiar Light Kit

Parts List and Installation Instructions

Table of Contents

Parts List	1
Safety Information	2
Plow Light Installation	
Straight Blade	3
EZ-V® Snowplow	3
Vehicle Harness Installation	3
Connector Pin Installation (EZ-V Snowplow Only)	4
Cable Installation	5
Peculiar Harness Installation	6
Relay Connections Diagram	7
System Diagram	
Straight Blade	8
EZ-V Snowplow	9

22242 Peculiar Light Harness		
Part #	Qty	Description
22241	1	Plug -in Harness 1A & 2A-C
8294	4	Jumper Wire
8293	2	Headlight Relays SPDT
8329K	1	Dielectric Grease
3666	8	Hose Ties
20681	1	Battery Cable, 50"
26013	1	Fuse Holder Assy.

Safety Information

Read this manual and labels on the snowplow before installing or operating the snowplow.

⚠ WARNING

Indicates a potentially hazardous situation that, if not avoided, could result in death or serious personal injury.

⚠ CAUTION

Indicates a situation that, if not avoided, could result in minor personal injury and/or damage to product or property.

NOTE: Identifies tips, helpful hints and maintenance information the reader should know.



⚠ CAUTION

Batteries normally produce explosive gases which can cause personal injury. Therefore, do not allow flames, sparks or lit tobacco to come near the battery. When charging or working near a battery, always cover your face and protect your eyes, and also provide ventilation.

Batteries contain sulfuric acid which burns skin, eyes and clothing.

Disconnect the battery before removing or replacing any electrical components.

Torque all fasteners according to the torque chart. For proper fit, do not tighten fasteners until instructed to do so.

NC FASTENER TORQUE (FT-LB)			
DIAMETER- THREADS PER INCH	GRADE		
			
	G2	G5	G8
1/4 - 20	6	9	13
5/16 - 18	11	18	28
3/8 - 16	19	31	46
7/16 - 14	30	50	75
1/2 - 13	45	75	115
9/16 - 12	66	110	165
5/8 - 11	93	150	225
3/4 - 10	150	250	370
7/8 - 9	150	378	591
1 - 8	220	583	893

Plow Light Installation

1. Install plow lights according to light kit installation instructions.
2. Install the solenoid wires according to the instructions on the inside solenoid covers.

NOTE: The strain relief(s) must be inside the covers to prevent the connections from coming loose.

Straight Blade

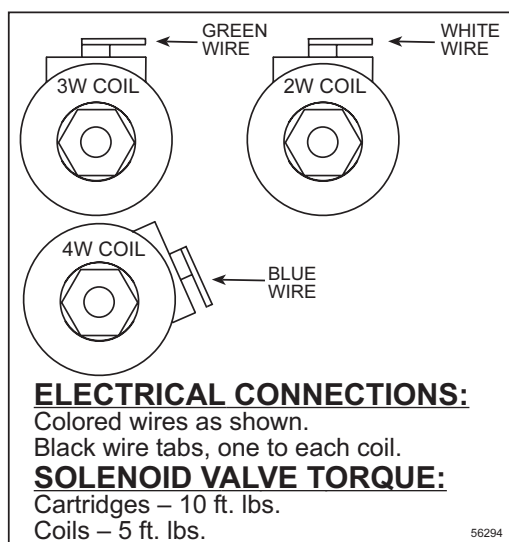

Vehicle Harness Installation

1. Stretch the rectangular opening of the plug cover strap over the grill plug end of the vehicle harness. Place the plug cover over the molded grill plug on the harness.

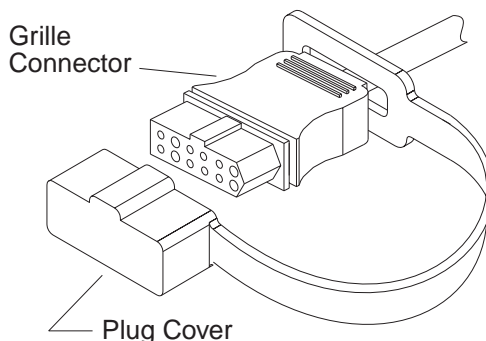

2. Select a location at a convenient height in driver-side grille for the connection to the plow plug. Slide the groove of the grille connector into the grille plate.
3. Route the vehicle harness through the selected location, into the engine compartment behind the driver-side headlamp(s).
4. Use cable ties to secure grille plate to the vehicle.
5. After connecting the plow plug with the grille connector, stretch the plug cover over the legs of the hook as shown.

EZ-V® Snowplow

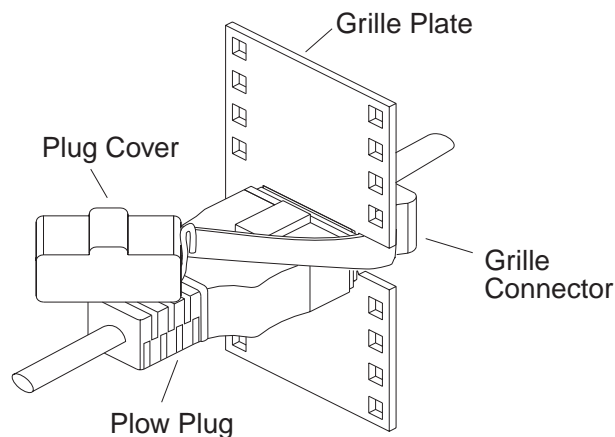
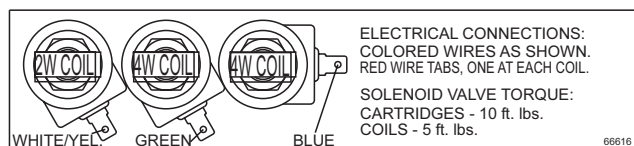
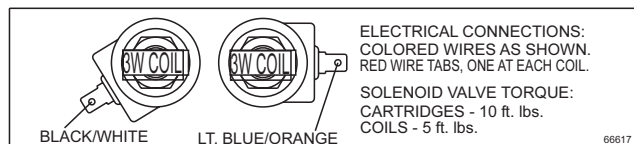
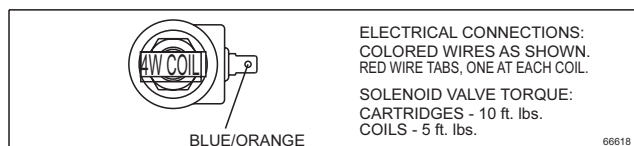

7. On the driver side of the vehicle, identify the left turn signal wire and parking lamp wires. Attach a black bullet receptacle connector to each wire.
8. Identify the right turn signal wire on the passenger side of the vehicle. Attach a black bullet receptacle connector to this wire.
9. On the driver side of the vehicle, insert the gray and brown bullet wires into the black bullet receptacles with the gray wire to turn signal and the brown wire to park lamp.
10. Connect the wires with the 1/4" receptacles to the headlamp relays behind the driver-side headlamps(s) as shown in the relay diagram.
11. Route the vehicle harness:

Straight Blade: Route the vehicle harness through the same hole as the 4-wheel drive control cables. Feed the fuse holder through first, then the plastic connector and harness.

EZ-V® Snowplow: Remove the packing material from the end of the harness near the fuse. This will expose ten socket-type terminals. Route the vehicle harness through the same hole as the 4-wheel drive control cables. Feed the fuse holder through first, then the plastic connector and harness.

12. Connect the red wire from the fuse holder to a circuit which is on only when the ignition key is on. Use the supplied fuse taps and insulated receptacles.

Connector Pin Installation (EZ-V Snowplow only)

1. In the cab, pass the ten socket-type terminals through the connector mount bracket.
2. Insert each of the ten socket-type terminals into the connector housing.

NOTE: You will feel a snap as the terminals are successfully inserted. An extraction tool is provided for removing pin terminals if necessary. Keep this tool for future use.

Wire Color	Pin No.
Light Blue w/ Orange Stripe	1
Blue w/ Orange Stripe	2
Black w/ White Stripe	3
Light Green	4
Light Blue	5
White w/ Yellow Stripe	6
Brown w/ Red Stripe	7
Red	8
Orange w/ Black Stripe	9
Brown w/ Green Stripe	10

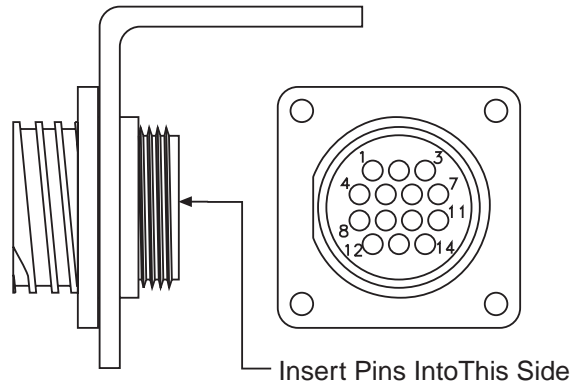

3. Mount the connector bracket to the vehicle with the supplied #6 sheet metal screws and washers. Secure the connector to the bracket with the 6-32 screws, lock washers and nuts.

Vehicle Cable Assembly Installation

1. Find a place on the passenger side of the vehicle to attach the vehicle cable assembly plug within reach of the plow cable plug. Install the grille plate by sliding it into the groove on the molded plug. Secure the grille plate to the vehicle with cable ties.
2. Route the vehicle cable through the selected location, across the frame to the driver-side, continue routing the cable along the top of the driver-side frame towards the battery. Cable tie vehicle cable assembly to existing clips or brackets.
3. Mount the motor relay within reach of the vehicle cable leads. Find a location for the motor relay where it will be protected from road splash.

NOTE: The motor relay must be mounted either vertical or horizontal.

4. Drill two 9/32" holes using the motor relay mounting plate as a template. Mount the motor relay to the holes using 1/4" x 3/4" cap screws, washers and locknuts.
5. Connect the 50" battery cable and the red wire from the fuse holder assembly to one of the large motor relay terminals:

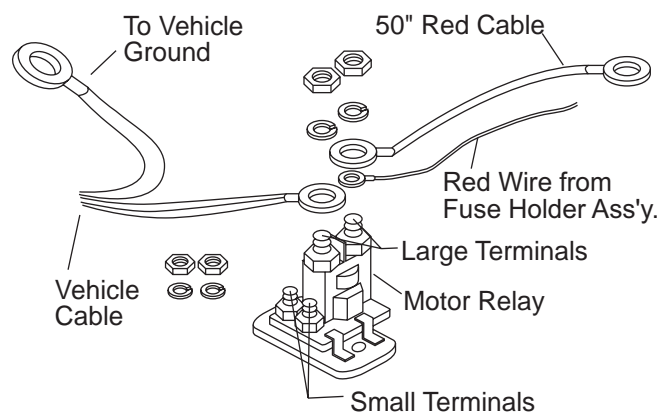

Straight Blades: Connect the black/red stripe cable to one of the large motor relay terminals with one 5/16-24 jam nut and lock washer. Split vehicle cable as required to attach cable without a stripe (black lead) to a ground bolt on the frame or engine. Remove any paint or dirt from around the hole or bolt when using the frame as a ground.

EZ-V® Snowplow: Attach the red wire from the vehicle cable to one of the large terminals on the motor relay. Secure with a lock washer and 5/16" jam nut. Attach the black lead to a ground bolt on frame or engine. Remove any paint or dirt from around the hole or bolt when using the frame as a ground.

6. Attach the 50" battery cable and the red wire from the fuse holder assembly to the second large motor relay terminal with one 5/16-24 jam nut and lock washer. Connect the other end to the "positive" battery terminal. Cable tie battery cable away from any sharp, hot or moving parts.
7. Route the wires:

Straight Blade: In the engine compartment, route the brown/red wire and the orange/black wire to the motor relay. Attach the ring terminals to the small motor relay terminal with 10-32 nuts and lock washers. Connect the 24" orange/black wire to ground.

EZ-V Snowplow: Route the harness breakout with the orange/black stripe, brown/red, and brown/green stripe wires to the motor relay. Install the brown/red stripe and brown/green stripe wires to the small terminals of the motor relay. Secure with #10 lock washers and 10-32 nuts. Connect the 24" orange/black wire to ground. Connect the insulated female receptacle on the small red wire from the vehicle harness to the insulated blade terminal on the small red wire from the vehicle battery cable.

8. Use cable ties to secure harness and wires away from any sharp, hot or moving parts.

NOTE: Use dielectric grease on all electrical connections to prevent corrosion. Fill receptacles and lightly coat ring terminals and blades before assembly.

Peculiar Harness Installation

1. Remove the headlamp connectors on the driver side. Connect the peculiar harness male connector to the 3-position female connector removed from the headlamps. Connect the peculiar harness female connectors to the headlamps.
2. Route the other end of the harness along the frame, to the passenger-side headlamps.
3. Remove the headlamp connectors on the passenger side. Connect the peculiar harness female connectors to the headlamps. Connect the peculiar harness male connector to the 3-position female connector removed from the headlamp. Secure any unused connectors with cable ties.
4. Insert the purple wire bullet into the black bullet receptacle on the passenger-side turn signal wire.
5. Insert the purple wire bullet from the vehicle harness into the purple wire receptacle on the peculiar harness.
6. Connect the remaining wires on the driver side to the headlamp relays as shown.
7. Use cable ties to secure the relays and prevent accidental grounding of any connections. Cable tie any harnesses and wires away from hot or moving engine parts.
8. Replace the vehicle turn signal flasher if one was furnished in kit.
9. Reconnect the vehicle battery positive (+) and negative (-) cables.
10. Aim headlamps according to the instructions.

Relay Connections Diagram

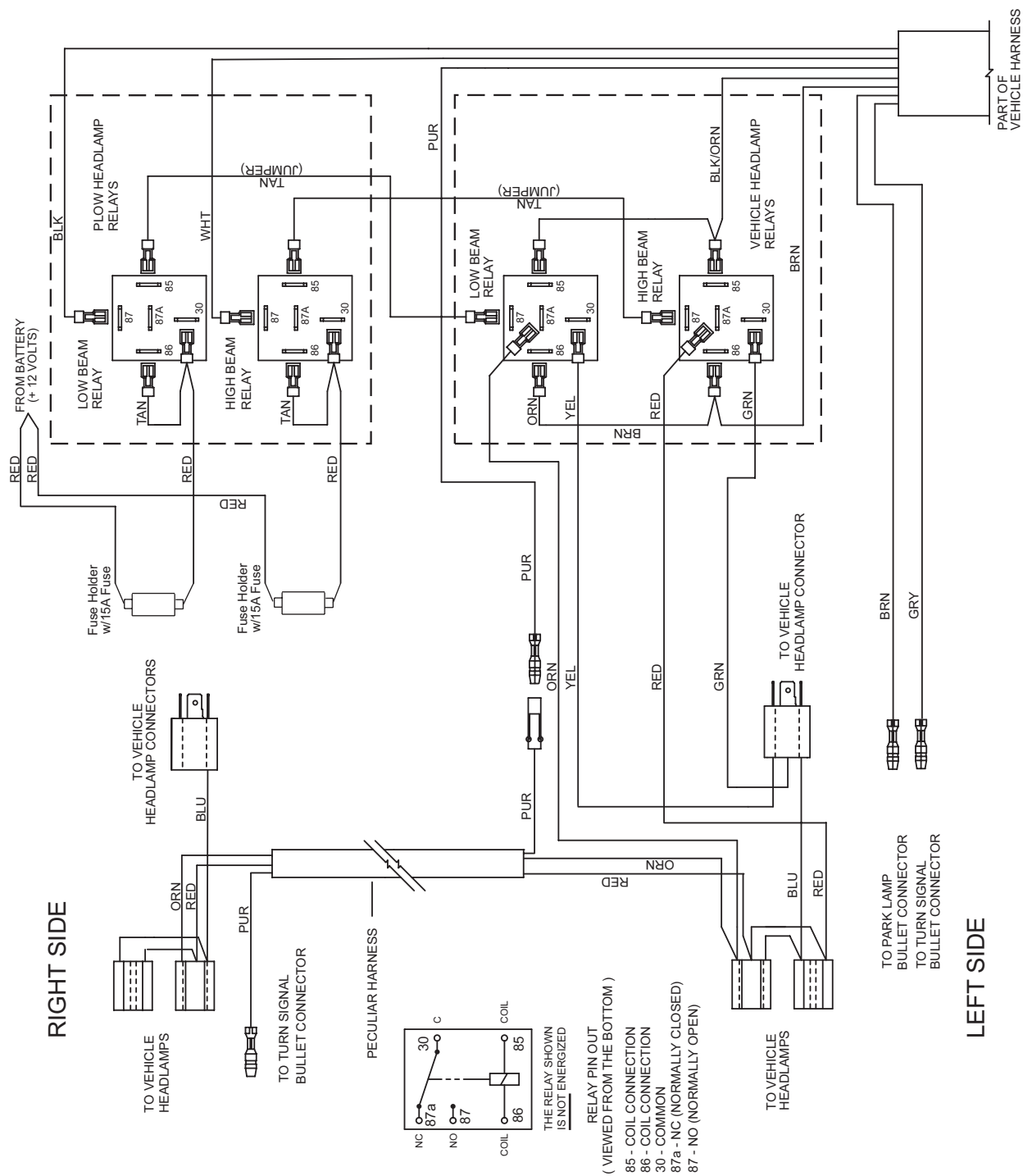

Straight Blade System Diagram

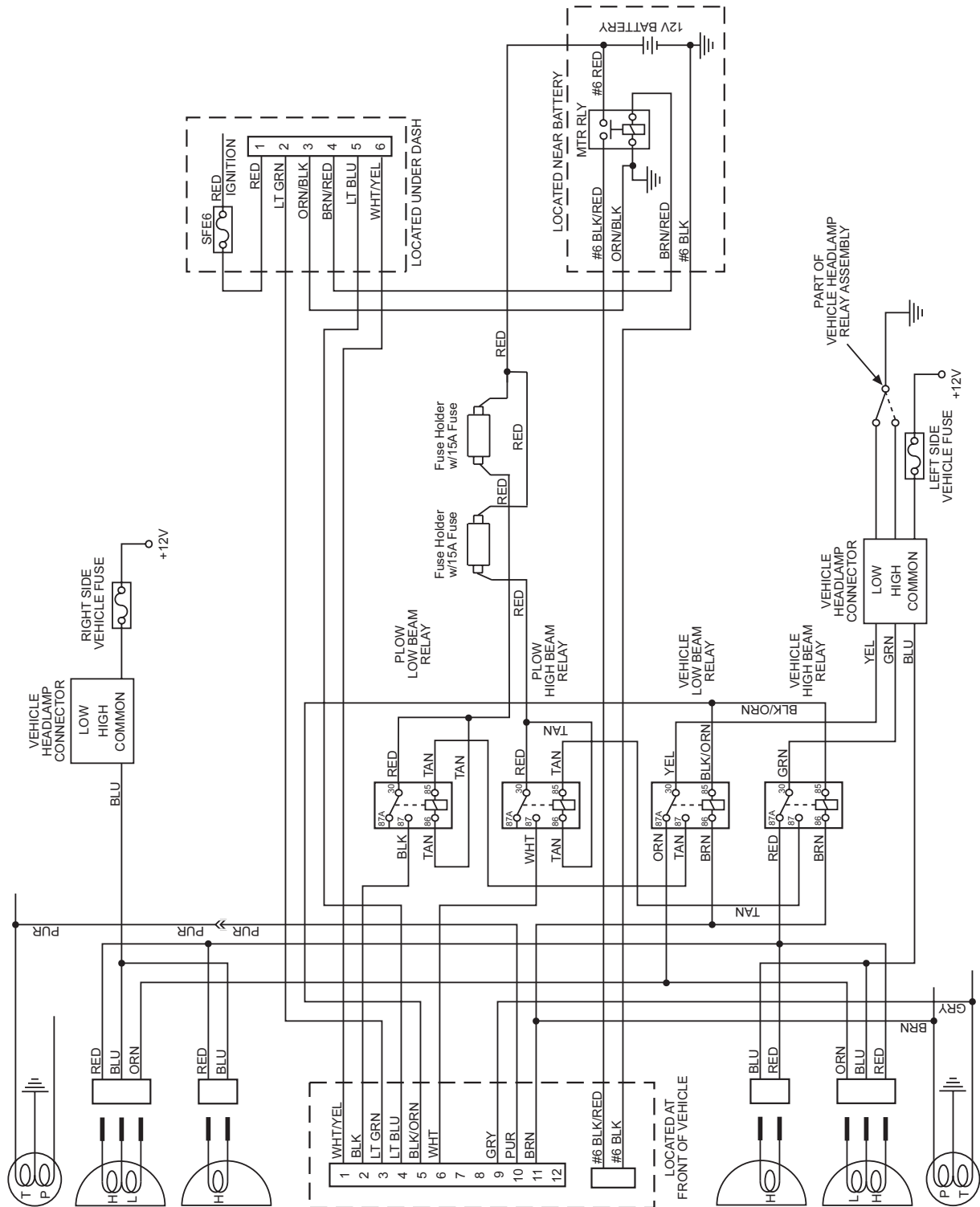

EZ-V® Snowplow System Diagram

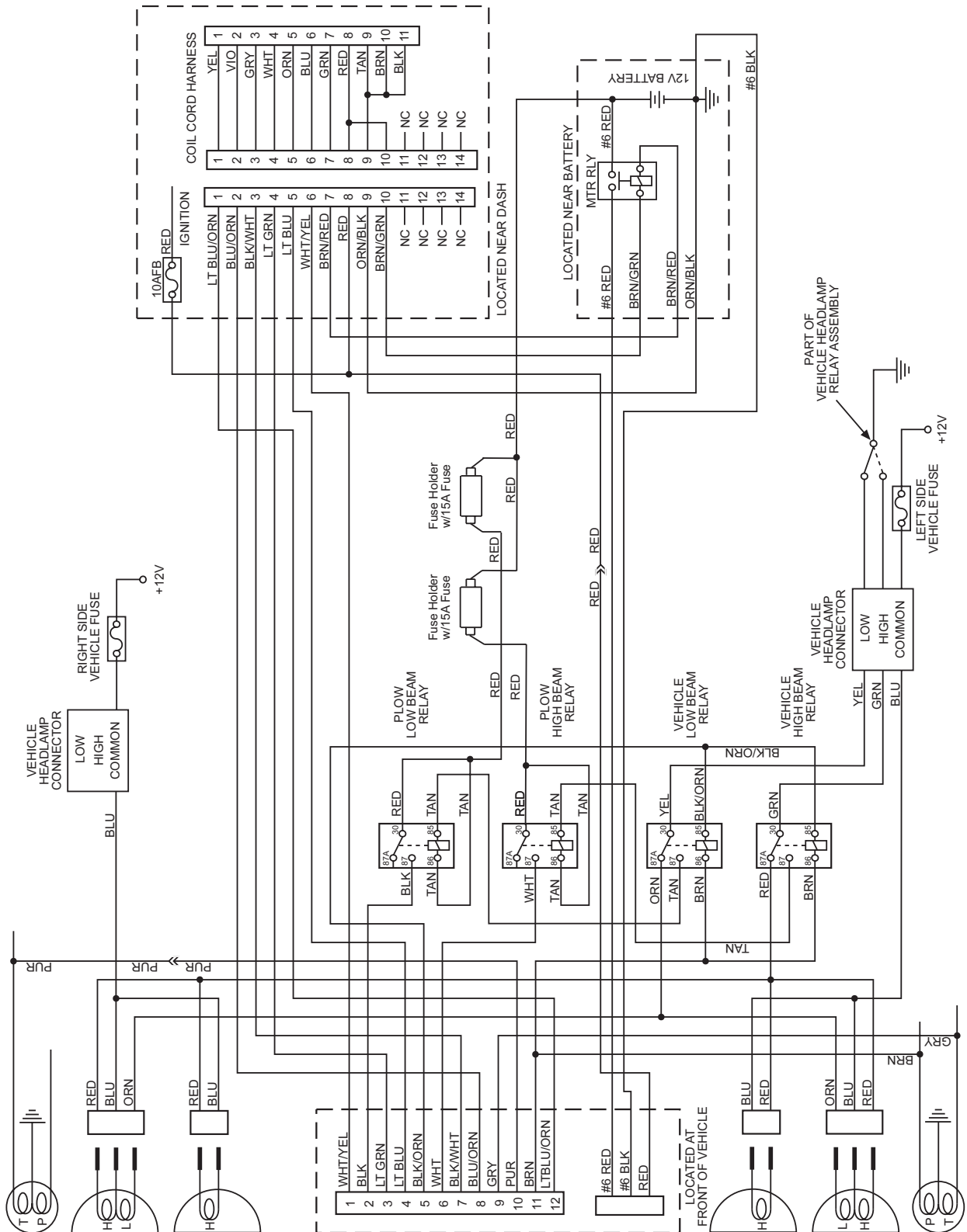

Copyright © 1998 Douglas Dynamics, L.L.C. All rights reserved. This material may not be reproduced or copied, in whole or in part, in any printed, mechanical, electronic, film or other distribution and storage media, without the written consent of Fisher Engineering. Authorization to photocopy items for internal or personal use by Fisher Engineering outlets is granted.

Fisher Engineering reserves the right under its product improvement policy to change construction or design details and furnish equipment when so altered without reference to illustrations or specifications used herein. Fisher Engineering and the vehicle manufacturer may require and/or recommend optional equipment for snow removal. This product is manufactured under the following patents 4,280,062, 4,999,935, 5,353,530, 5,420,480, RE35700 and other patents pending. Fisher Engineering offers a limited warranty for all snowplows and accessories. See separately printed page for this important information. The following are registered (®) and unregistered (™) trademarks of Douglas Dynamics, L.L.C.: EZ-V®, FISHER®

Printed in USA