

BLIZZARD[®] **SPEEDWING**[™]



Model 760SW & 860SW SPEEDWING[™] Snowplows Installation Instructions & Owner's Manual

⚠ CAUTION

See your BLIZZARD[®] sales outlet/Web site for specific vehicle application recommendations before installation. The Undercarriage Selection Guide has specific vehicle and snowplow requirements.

⚠ CAUTION

Read this document before installing the snowplow.

⚠ CAUTION

Read this document before operating or servicing snowplow.

This manual supersedes all editions with an earlier date.

Congratulations on purchasing the newest innovation in snowplowing available! BLIZZARD® SPEEDWING™ blades create a whole new category for multi-position truck-mounted snowplows. Our innovative products are tested all over the snowbelt.

This manual provides safety, operation and maintenance information for your new BLIZZARD snowplow. To keep your snowplow in good condition, read and understand this manual and follow its recommendations. Failure to do so may affect your warranty coverage.

When service is necessary, your local BLIZZARD distributor knows your snowplow best. Contact your BLIZZARD outlet for maintenance, service or any other assistance you may require.

If you have not already done so, please visit www.blizzardplows.com to register your new BLIZZARD snowplow!



TABLE OF CONTENTS

SAFETY INFORMATION	4	POWER HITCH™ SYSTEM INSTRUCTIONS	30
VEHICLE APPLICATION INFORMATION	7	TESTING YOUR SNOWPLOW	31
OPERATION	8	HEADLAMP AIMING	33
UNPACKING & INSPECTION	9	MAINTENANCE	34
TORQUE SPECIFICATIONS	10	TECHNICAL SPECIFICATIONS	35
MOLDBOARD & A-FRAME ASSEMBLY	12	TROUBLESHOOTING	36
ELECTRICAL & HYDRAULIC SYSTEMS	17	PARTS LISTS—ALL MODELS	38
General System Schematics.....	17	Moldboard and Wing Parts	38
Hydraulic Guide.....	18	A-Frame and Pivot Beam Parts	40
Electrical Installation—Snowplow Side.....	19	Draw Latch and Final Assembly Parts	42
Electrical Schematics—Snowplow Side	20	Power Unit Parts	44
Electrical Installation—Vehicle Side	23	Lights, Harnesses and Control Parts.....	46
Electrical Schematics—Vehicle Side	26	Accessories and Kits	48

SAFETY

SAFETY DEFINITIONS

⚠ WARNING

Indicates a potentially hazardous situation that, if not avoided, could result in death or serious personal injury.

⚠ CAUTION

Indicates a potentially hazardous situation that, if not avoided, may result in minor or moderate injury. It may also be used to alert against unsafe practices.

NOTE: Indicates a situation or action that can lead to damage to your snowplow and vehicle or other property. Other useful information can also be described.

WARNING/CAUTION AND INSTRUCTION LABELS

Become familiar with and inform users about the warning and instruction labels on the back of the blade.

NOTE: If labels are missing or cannot be read, see your sales outlet.

MOUNT INSTRUCTIONS		DISMOUNT INSTRUCTIONS	
Read Owner's Manual for Complete Instructions		Read Owner's Manual for Complete Instructions	
STEP #1 		STEP #1 	
⚠ WARNING: Keep fingers away. POWER HITCH arm raises behind undercarriage pushbeam.			
<ul style="list-style-type: none"> Kickstand must be lowered, with kickstand pin seated in lower hole on pivot beam. Slowly drive vehicle forward until pushbeam receiver mount points contact A-frame mount bushings. Turn POWER HITCH OPERATION switch (on plow control) to "ON" position. Connect plow and vehicle electrical harnesses. Connect weather caps together. 		<ul style="list-style-type: none"> Raise plow. Lower kickstand until kickstand pin is seated in lower hole on pivot beam. Lower plow on flat, level surface. Turn vehicle ignition off. Remove hitch pins from A-frame and undercarriage. Turn vehicle ignition on. Turn POWER HITCH OPERATION switch (on plow control) to "ON" position. 	
STEP #2 		STEP #2 	
⚠ WARNING: Keep fingers away from plow and truck mounting points.			
<ul style="list-style-type: none"> Pull A-frame latch lock pin out and lower A-frame latch over draw pin. Push and hold CONNECT/DISCONNECT switch upward. POWER HITCH arm will engage back of pushbeam and pull plow into pushbeam receiver mount points on vehicle. Insert both hitch pins and secure each with hair pin cotter. Lower POWER HITCH arm to relieve tension on A-frame latch. Raise A-frame latch and lock into position with lock pin. Raise plow. Raise kickstand until kickstand pin seats into upper hole on pivot beam. 		<ul style="list-style-type: none"> Push and hold CONNECT/DISCONNECT switch downward. POWER HITCH arm will disengage from behind undercarriage pushbeam and lower. Disconnect plow and vehicle electrical harnesses. Install weather caps. Turn SYSTEM POWER (on plow control) to "OFF" position. Slowly move vehicle backward away from plow. 	
<small>U.S. Patents 5,638,518; 5,690,007; 6,178,689; 6,276,076; 6,993,707; 6,408,549; 6,412,199; 6,442,877; 6,916,513; Canadian and other patents pending. 44812</small>			

⚠ WARNING	
	Lower blade when vehicle is parked.
	Do not exceed GVWR or GAWR including blade and ballast.
⚠ CAUTION	
	Read Owner's Manual before operating or servicing snowplow.
	Transport speed should not exceed 45 mph (72 km/h). Further reduce speed under adverse travel conditions.
	Plowing speed should not exceed 10 mph (16 km/h).
	See your sales outlet/Web site for specific vehicle application recommendations. 99900

⚠ WARNING	
Multiple Pinch Points	
<small>28593</small>	

⚠ WARNING	
Crush hazard. Keep feet clear.	

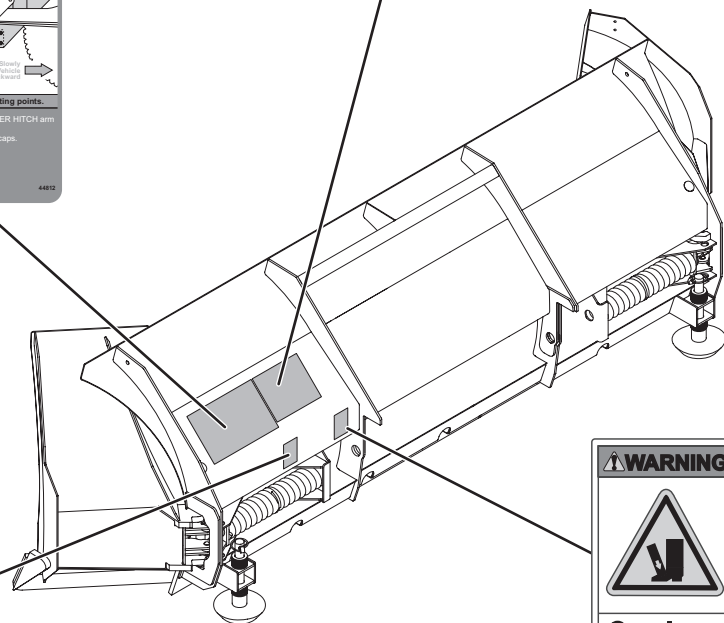

SAFETY

SAFETY PRECAUTIONS

Improper installation and operation could cause personal injury and/or equipment and property damage. Read and understand labels and the Owner's Manual before installing, operating or making adjustments.

⚠ WARNING

Lower the blade when the vehicle is parked. Temperature changes could change hydraulic pressure, causing the blade to drop unexpectedly or damaging hydraulic components. Failure to do this could result in serious personal injury.

⚠ WARNING

You can die or be seriously injured. Keep hands and feet away from hitch mechanism and snowplow blade when operating the POWER HITCH™ arm. The action of the arm moves the snowplow toward the vehicle and into position for proper attachment.

⚠ WARNING

The driver shall keep bystanders clear of the blade when it is being raised, lowered or angled. Do not stand between vehicle and blade or within 8 feet of a moving blade. A moving or falling blade could cause personal injury.

⚠ WARNING

Do not exceed GVWR or GAWR including the blade and ballast. The rating label is found on the driver-side vehicle door cornerpost.

⚠ WARNING

To prevent accidental movement of the blade, always turn the control OFF whenever the snowplow is not in use. The power indicator light will turn OFF.

⚠ WARNING

Remove blade assembly before placing vehicle on hoist.

⚠ CAUTION

Read Owner's Manual before operating or servicing snowplow.

⚠ CAUTION

Transport speed should not exceed 45 mph (72 km/h). Further reduce speed under adverse travel conditions.

⚠ CAUTION

Plowing speed should not exceed 10 mph (16 km/h).

⚠ CAUTION

See your BLIZZARD® outlet for application recommendations.

HYDRAULIC SAFETY

⚠ WARNING

Hydraulic fluid under pressure can cause skin injection injury. If you are injured by hydraulic fluid, get medical attention immediately.

- Always inspect hydraulic components and hoses before using. Replace any damaged or worn parts immediately.
- If you suspect a hose leak, DO NOT use your hand to locate it. Use a piece of cardboard or wood.

FUSES

The electrical and hydraulic systems contain several blade-style automotive fuses. If a problem should occur and fuse replacement is necessary, the replacement fuse must be of the same type and amperage rating as the original. Installing a fuse with a higher rating can damage the system and could start a fire. Fuse Replacement, including fuse ratings and locations, is located in the Maintenance Section of this Owner's Manual.

SAFETY

PERSONAL SAFETY

- Remove ignition key and put the vehicle in park or in gear to prevent others from starting the vehicle during installation or service.
- Wear only snug-fitting clothing while working on your vehicle or snowplow.
- Do not wear jewelry or a necktie, and secure long hair.
- Wear safety goggles to protect your eyes from battery acid, gasoline, dirt and dust.
- Avoid touching hot surfaces such as the engine, radiator, hoses and exhaust pipes.
- Always have a fire extinguisher handy, rated BC for flammable liquids and electrical fires.

FIRE AND EXPLOSION

⚠ WARNING

Gasoline is highly flammable and gasoline vapor is explosive. Never smoke while working on vehicle. Keep all open flames away from gasoline tank and lines. Wipe up any spilled gasoline immediately.

Be careful when using gasoline. Do not use gasoline to clean parts. Store only in approved containers away from sources of heat or flame.

CELL PHONES

A driver's first responsibility is the safe operation of the vehicle. The most important thing you can do to prevent a crash is to avoid distractions and pay attention to the road. Wait until it is safe to operate Mobile Communication equipment such as cell phones, text messaging devices, pagers or two-way radios.

VENTILATION

⚠ WARNING

Vehicle exhaust contains lethal fumes. Breathing these fumes, even in low concentrations, can cause death. Never operate a vehicle in an enclosed area without venting exhaust to the outside.

BATTERY SAFETY

⚠ CAUTION

Batteries normally produce explosive gases, which can cause personal injury. Therefore, do not allow flames, sparks or lit tobacco to come near the battery. When charging or working near a battery, always cover your face and protect your eyes, and also provide ventilation.

- **Batteries contain sulfuric acid, which burns skin, eyes and clothing.**
- **Disconnect the battery before removing or replacing any electrical components.**

NOISE

Airborne noise emission during use is below 70 dB(A) for the snowplow operator.

VEHICLE APPLICATION INFORMATION

⚠ CAUTION

See your BLIZZARD® outlet for specific vehicle application recommendations before installation. The Undercarriage Selection Guide has specific vehicle and snowplow requirements.

Vehicle application recommendations are based on the following:

- The vehicle with the snowplow installed must comply with applicable Federal Motor Vehicle Safety Standards (FMVSS).
- The vehicle with the snowplow installed must comply with the vehicle manufacturer's stated gross vehicle and axle weight ratings (found on the driver-side door cornerpost of the vehicle) and the front and rear weight distribution ratio. In some cases, rear ballast may be required to comply with these requirements.
- BLIZZARD Undercarriage Selection Guide is based on available vehicle capacity for snowplow equipment on a representative vehicle equipped with options commonly used for snowplowing and with 300 lb of front seat occupant weight.
- Weights of front seat occupants can be adjusted above 300 lb, but vehicle with snowplow must not exceed vehicle GVWR or GAWR.
- In some cases there may be additional limitations and requirements.
- Installation, modification and addition of accessories must comply with published BLIZZARD recommendations and instructions. Available capacity decreases as the vehicle is loaded with cargo or other truck equipment or snowplow accessories are installed.
- If there is uncertainty as to whether available capacity exists, the actual vehicle as configured must be weighed.

BALLAST REQUIREMENTS

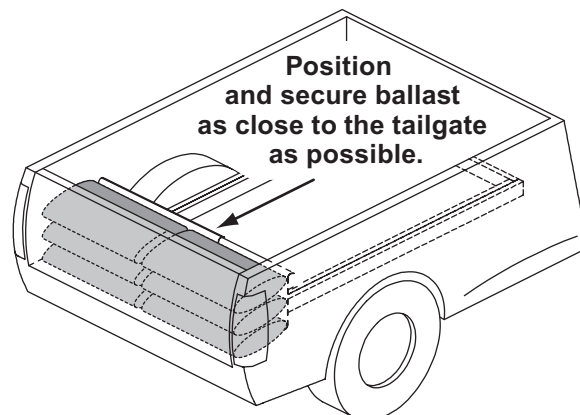

Ballast (additional weight) is an important part of qualifying vehicles for snowplow eligibility. Rear ballast must be used when necessary to remain in compliance with axle ratings and ratios as specified by the vehicle manufacturer.

If ballast is required, it is important that it be secured properly behind the rear axle. A ballast retainer kit is available from your BLIZZARD outlet, PN 62849.

NOTE: The ballast retainer kit is for snowplow vehicles requiring ballast. See your BLIZZARD outlet for the correct amount of ballast required. Include the weight of the retainer as part of the ballast requirement. Sand bags are recommended for use as ballast.

NOTE: Ballast recommended and its weight calculations assume the entire width of the bed is filled as close to tailgate as possible.

OPERATION

Your SPEEDWING™ snowplow is the newest multi-position snowplow on the market. The easy-to-use controls allow you to automatically adjust the snowplow blade into a variety of plowing positions. Review the illustrations below for instruction on maneuvering your snowplow.

A. Lowered or Float Position

Pushing the joystick forward, toward the "Lower/Float" designation on the label, or pushing the D button on the touchpad will lower your blade to the ground. Pushing and momentarily holding the control in this position will allow the snowplow to "float," or follow the contour of the ground when moving forward or backward.

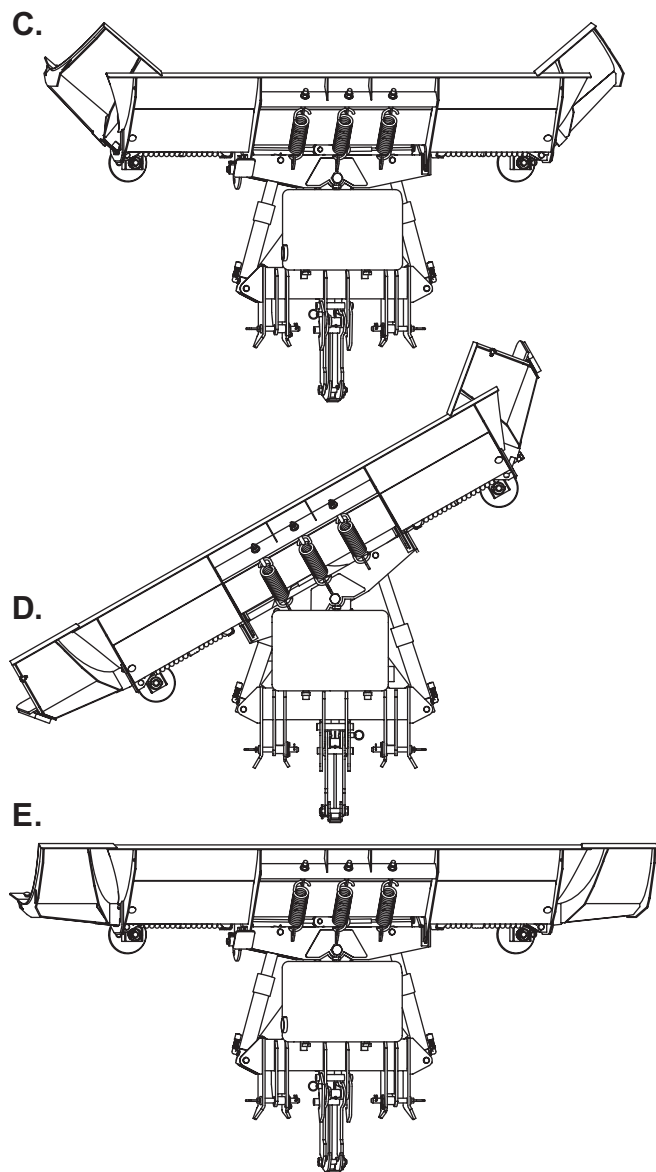

B. Raised Position

Pulling the joystick back, toward the "Raise" designation on the label, or pushing the U button on the touchpad will lift your blade off the ground. To stop raising the snowplow, simply return the joystick to its neutral (center) position or release the touchpad button. The snowplow has reached its maximum raised height when the blade stops lifting.

C. BUCKET BLADE™ Position (7'-7" or 8'-7" Blade Width)

Automatic position when blade is not angled; creates a scoop and eliminates trails.

- Primary position for transporting snow
- For use in initial clearing with decent visibility, transporting large volumes of snow, final clean-up
- *Ideal application: residential driveways, small roads, roadway intersections*

D. Angled Width with Trailing Wing (6'-7" or 7'-10" Blade Width)

To angle your blade, position the joystick toward the "R" or "L" on the label or push the R or L button on the touchpad. An angled blade will automatically extend the trailing wing. To stop angling the blade, return the joystick to its neutral (center) position or release the touchpad button. The blade has reached its maximum angled position when it stops moving to the side.

- Primary position for accelerated angled plowing
- For use in directional plowing, cornering, diverting snow away from objects or buildings
- *Ideal application: plowing adjacent to buildings, driveway/road intersections*

E. Back Blade Position (8'-7" or 9'-9" Blade Width)

Lock the wings into place to create the largest clearing path and get the most out of your wings.

- Primary position for clearing large surfaces
- For use in light snow conditions with good visibility, final clearing and clean-up
- *Ideal application: large parking lots, widening roadways*

NOTE: To prevent premature failure of the power contactor (solenoid), return the joystick to its neutral (center) position, or release the touchpad button, immediately after the blade reaches the limit of any position. Continuing to hold the control after the blade has reached the limit of movement in any position will reduce the life of the solenoid.

UNPACKING & INSPECTION

Your BLIZZARD® SPEEDWING™ snowplow has been packaged to withstand transit and weather related damage. Fully inspect all components upon receipt of your snowplow. In the event of shipping damage or missing parts, immediately contact our Customer Support Department at 1-888-680-8600.

Begin unpacking and inspection in the following order:

1. Remove the shipping document from the end panel of the pallet wrap. Retain all documentation for your records.
2. All wood framing and polyethylene material should be removed from the pallet for easy access to the snowplow.
3. Due to the odd-shaped components and size of several assembly parts, various cable ties and corrugated material are used for scratch resistance and package orientation. Please remove these items prior to assembly.
4. Place the main blade assembly on a flat, level surface.

Once you have inspected all parts and removed all packaging materials, your snowplow is ready to be fully assembled.

Retain this information for your records.

Date of Purchase: _____

Dealer/Distributor: _____

Dealer Phone Number: _____

Snowplow Serial Number: _____

Hydraulic Pump Serial Number: _____

TORQUE SPECIFICATIONS

TORQUE CHART

⚠ CAUTION

Read instructions before assembling.
Fasteners should be finger tight until instructed to tighten according to the torque chart.
Use standard methods and practices when attaching snowplow, including proper personal protective safety equipment.



Grade Identification for J429–Grade 5 Bolt



Grade Identification for J429–Grade 8 Bolt

SAE J429 Grade 5 Torque Values				SAE J429 Grade 8 Torque Values			
Nominal Thread Size	Clamp Loads (lb)	Tightening Torque		Nominal Thread Size	Clamp Loads (lb)	Tightening Torque	
		"Lubricated"	"Dry"			"Lubricated"	"Dry"
1/4-20	2,000	6 ft-lb	8 ft-lb	1/4-20	2,850	9 ft-lb	12 ft-lb
5/16-18	3,350	13 ft-lb	18 ft-lb	5/16-18	4,700	18 ft-lb	25 ft-lb
3/8-16	4,950	23 ft-lb	31 ft-lb	3/8-16	6,950	32 ft-lb	44 ft-lb
7/16-14	6,800	37 ft-lb	50 ft-lb	7/16-14	9,600	53 ft-lb	70 ft-lb
1/2-13	9,050	57 ft-lb	75 ft-lb	1/2-13	12,800	80 ft-lb	107 ft-lb
9/16-12	11,600	82 ft-lb	109 ft-lb	9/16-12	16,400	115 ft-lb	154 ft-lb
5/8-11	14,500	113 ft-lb	151 ft-lb	5/8-11	20,300	159 ft-lb	211 ft-lb
3/4-10	21,300	200 ft-lb	266 ft-lb	3/4-10	30,100	282 ft-lb	376 ft-lb
7/8-9	29,435	321 ft-lb	430 ft-lb	7/8-9	41,550	454 ft-lb	606 ft-lb
1-8	38,600	482 ft-lb	640 ft-lb	1-8	54,540	680 ft-lb	900 ft-lb



8.8 Grade Identification for Metric–Grade 8.8 Bolt



10.9 Grade Identification for Metric–Grade 10.9 Bolt

Metric Class 8.8 Torque Values				Metric Class 10.9 Torque Values			
Diameter (mm)	Clamp Loads (lb)	Tightening Torque		Diameter (mm)	Clamp Loads (lb)	Tightening Torque	
		"Lubricated"	"Dry"			"Lubricated"	"Dry"
5	1,389	3 ft-lb	5 ft-lb	5	1,987	5 ft-lb	7 ft-lb
6	1,965	6 ft-lb	8 ft-lb	6	2,812	8 ft-lb	11 ft-lb
7	2,826	10 ft-lb	13 ft-lb	7	4,044	14 ft-lb	19 ft-lb
8	3,579	14 ft-lb	19 ft-lb	8	5,121	20 ft-lb	27 ft-lb
10	5,672	28 ft-lb	37 ft-lb	10	8,116	40 ft-lb	53 ft-lb
12	8,243	49 ft-lb	65 ft-lb	12	11,796	70 ft-lb	92 ft-lb
14	11,246	77 ft-lb	103 ft-lb	14	16,092	111 ft-lb	148 ft-lb
16	15,882	125 ft-lb	167 ft-lb	16	21,970	173 ft-lb	231 ft-lb
18	19,423	172 ft-lb	229 ft-lb	18	26,868	238 ft-lb	317 ft-lb
20	24,784	244 ft-lb	325 ft-lb	20	34,284	338 ft-lb	450 ft-lb

TORQUE SPECIFICATIONS

37° JIC Flare Torque Values			
Turns	Size	ft-lb min-max	Assembly Steps
N/A	-02	6-7	<ol style="list-style-type: none"> 1. Make sure the tubing and threads are clean. 2. Lubricate the threads with 10W hydraulic fluid. 3. Hand tighten the nut/sleeve to approximately 30 in-lb. 4. Make alignment marks on the nut and fitting. 5. Tighten to turn or torque specification. 6. When fully tightened, make a second set of alignment marks at the fully tightened position. <p>NOTE: Torque values specified are for threads lubricated with 10W hydraulic fluid. Overtightening will reduce the clamping force resulting in loss of seal and reduction of flow.</p>
N/A	-03	8-9	
2	-04	11-12	
2	-05	14-15	
1-1/2	-06	18-20	
1-1/2	-08	36-39	
1-1/2	-10	57-63	
1-1/4	-12	79-88	
1	-14	94-103	
1	-16	108-113	
1	-20	127-133	
1	-24	158-167	
1	-32	245-258	

O-Ring Boss Torque Values		
Size	ft-lb min-max	Assembly Steps
-02	6-7	<ol style="list-style-type: none"> 1. Verify that the port, O-ring, sealing surfaces and threads are clean and free of damage. 2. Lubricate the threads and the O-ring with 10W hydraulic fluid. 3. For an adjustable ORB, completely back off the locknut and washer. 4. Hand tighten the fitting until it contacts the port spotface. Point the elbow or tee in the desired direction and hold. 5. Torque to specification. <p>NOTE: Torque values specified are for threads lubricated with 10W hydraulic fluid.</p>
-03	8-10	
-04	13-15	
-05	17-21	
-06	22-25	
-08	40-43	
-10	43-57	
-12	68-75	
-14	90-99	
-16	112-123	
-20	146-200	
-24	154-215	
-32	218-290	

MOLDBOARD & A-FRAME ASSEMBLY

1. Install lift ram base end fitting. Attach one 9/16" 45° elbow ORB adapter (56695) to the driver-side port (base end).
2. Position the pivot beam and A-frame near the connecting points at the rear of the blade between the two center support ribs. Insert one bushing through each mounting hole and secure with retaining rings.

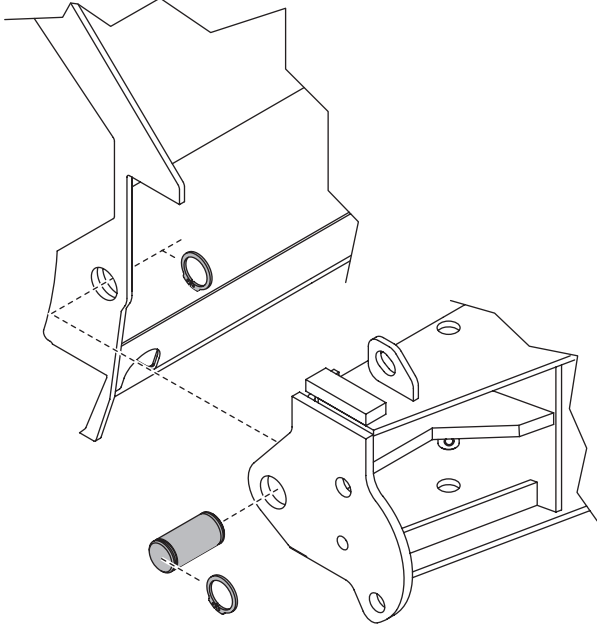

3. Mount the kickstand to the end of the pivot beam (driver's side) using the 1/2" x 4-1/2" cap screw provided. The spring, bushing and locknut are located on the inside of the pivot beam. Review the diagrams below and to the right. To pivot the kickstand, pull the spring-loaded leg out and rotate it until the pin locks into place. Adjust the foot on the stand arm so that the foot is 1/8" from the ground when the A-frame is level and the A-frame mount points are 12-1/2" from the ground. Tighten both of the locknuts on the kickstand.

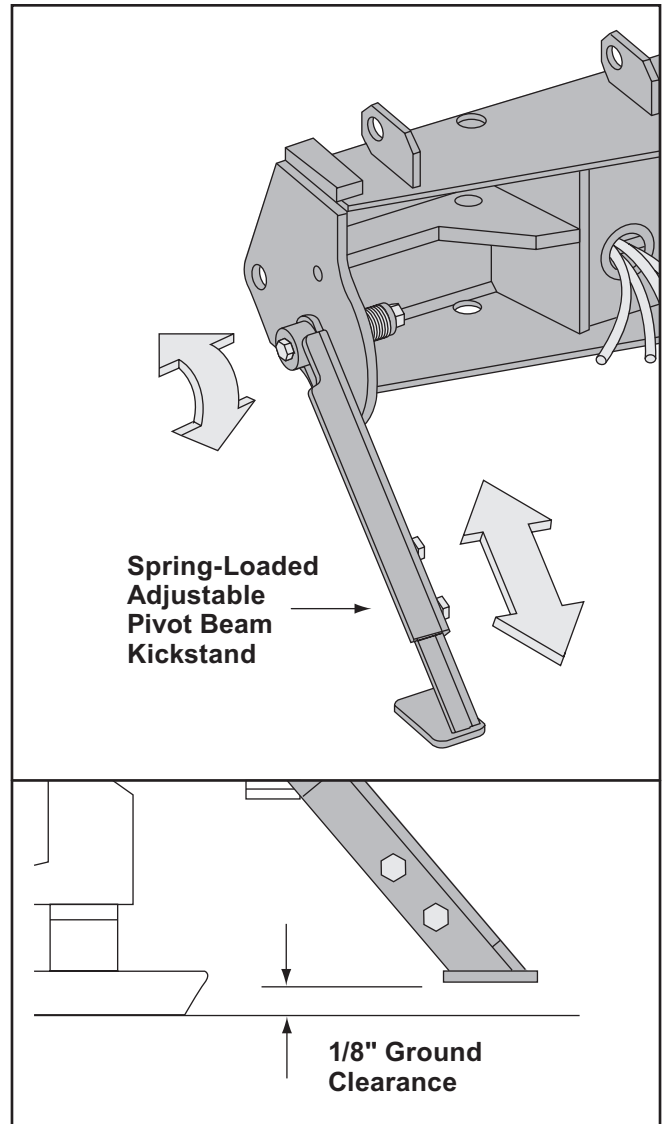
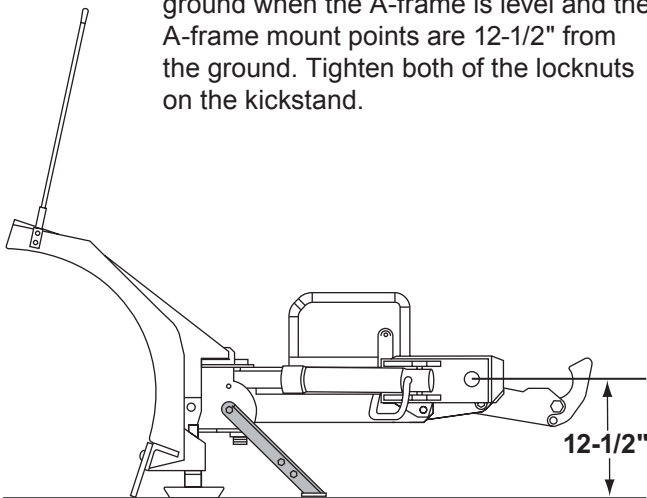

MOLDBOARD & A-FRAME ASSEMBLY

4. Position each angle cylinder with the rod end of the cylinder in the pivot beam and the hydraulic hose port facing away from the A-frame. Secure the cylinder to the pivot beam with a 3/4" x 4-5/8" clevis pin (95739) and a 1/4" x 1-1/2" cotter pin (90601). Extend each cylinder rod until the cylinder base mounting hole aligns with the hole on the A-frame angle cylinder bracket. Insert another clevis pin and secure it with a cotter pin.
5. Remove the dust cap from both of the hydraulic angle cylinder ports and attach one 9/16" 90° adjustable elbow ORB adapter (56590) to each port. Each adapter should be angled toward the top of the moldboard. Connect one 3/8" x 19" hydraulic hose (B60451) to the driver-side angle cylinder adapter. Connect the 3/8" x 20" hydraulic hose (B60452) to the passenger-side angle cylinder adapter. Be careful not to overtighten the hose connections. Route both hoses over the TOP of each cylinder. This will prevent them from hanging or being pinched. Tighten fittings and hoses per torque chart.
6. Remove the plastic dust caps from the hydraulic lift cylinder ports. Attach one 9/16" male ORB connector adapter (B60007) to the passenger-side port (rod end). Once the adapters have been installed on the cylinder, connect the hydraulic hoses. Tighten fittings and hoses per torque chart.

NOTE: Position the 45° fitting in the cylinder port so that the hoses install directly in the center of the A-frame access holes. A hose installed too close to the edge of the opening may work itself free with the operation of the lift cylinder and/or movement of the snowplow.

The 45° adapter receives a 3/8" x 17" hydraulic hose (B60273). Connect the 45° angle on the hose to the hydraulic adapter on the cylinder. The male connector adapter receives a 3/8" x 15" hydraulic hose (B60274). Connect the 45° end of the hose to the hydraulic adapter on the cylinder. Both hoses should be routed through the triangular openings in the A-frame. Tighten fittings and hoses per torque chart.

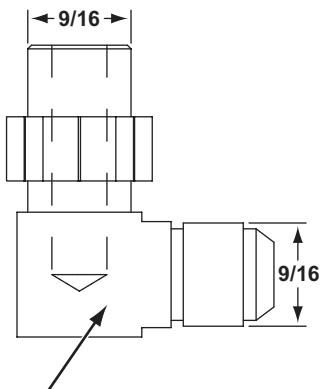

56590
- Manifold Port #3
- Angle Cylinders

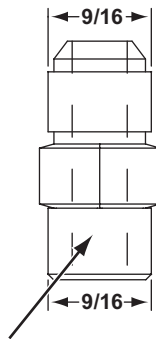

B60007
- Lift Cylinder Rod End

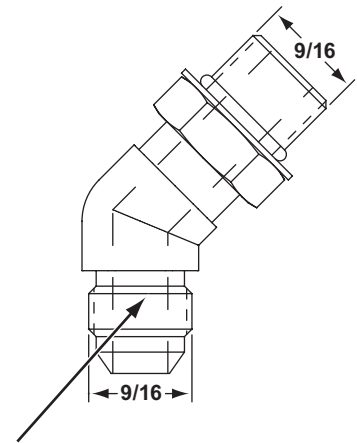

B60272
- Manifold Ports #1, 2 & 4
- Lift Cylinder Base End

MOLDBOARD & A-FRAME ASSEMBLY

7. Remove the draw latch mount pin, spacer and cotter pin from the draw latch assembly. By removing this pin, the inner draw latch plates can swing free. Remove the inner draw latch plate lift cylinder mount pin. Position the plates on either side of the lift/lower cylinder rod and insert the pin through the plates and cylinder rod. With the cylinder connected to the inner draw latch plates, rotate the draw latch assembly toward the draw latch mount holes on the A-frame. Align the holes in the outer draw latch plate with those of the inner draw latch plates and the A-frame.

NOTE: The A-frame latch, located at the rear/center of the A-frame, should be raised up to insert the draw latch mount pin. Pull the A-frame latch pull pin out and rotate the latch counterclockwise if it is locked into position.

Secure the assembly to the A-frame by replacing the draw latch mount pin, spacer and cotter pin. Reset the A-frame latch so the A-frame latch pull pin locks into place.

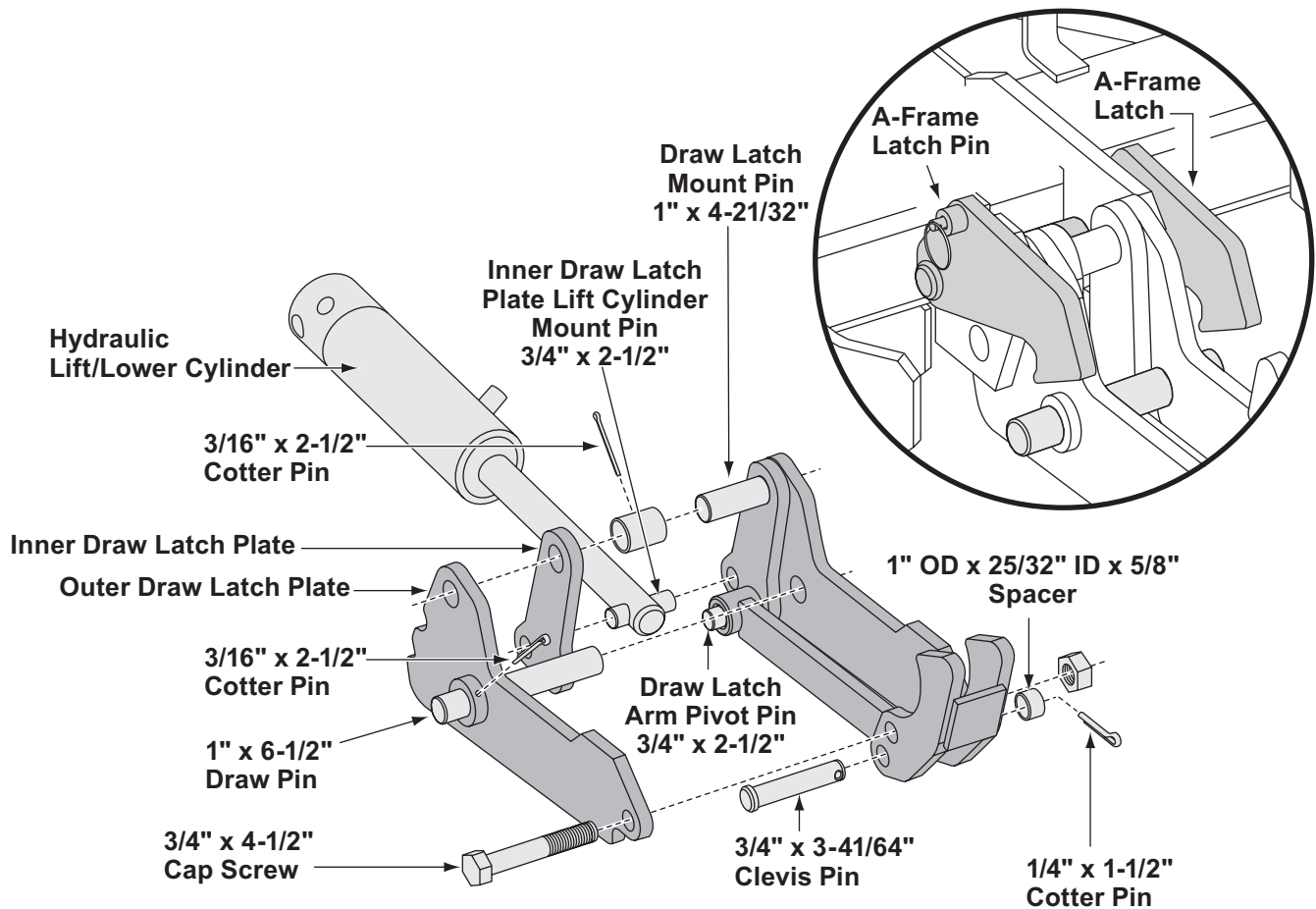

MOLDBOARD & A-FRAME ASSEMBLY

8. Assemble the manifold. The manifold, pump and coil harness have been connected at the factory; however, the manifold contains several components that you will need to install prior to securing the assembly to the A-frame. Each of the hose ports on the manifold is covered with stretch wrap. Remove the wrap and install the appropriate fitting in its respective port. Tighten fittings and hoses per torque chart.

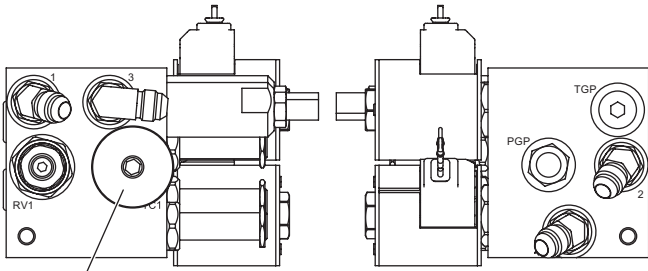

Flow Control Knob

NOTE: Install the adapters as shown on the manifold above to correctly receive the hydraulic hoses.

NOTE: The flow control will need to be removed to install the fitting into Port #3.

NOTE: DO NOT let any foreign objects enter into the open ports. The valves can become contaminated and greatly hinder the snowplow's performance. Torque to proper specifications.

NOTE: All ports are identified by a stamped number on the manifold. The numbers also identify the hydraulic functions, which can be referenced on the label under the hydraulic pump and manifold cover.

9. Remove the washers, split lock washers and cap screws from the manifold. Save this hardware to be reused later.

Align the mount holes in the pump with the holes in the bracket, located on the A-frame.

Insert 3/8" x 1-3/4" threaded stud with a 3/8" locknut through the bottom mount hole and line it up with the bottom mount hole in the manifold. Tighten the stud using the locknut. The stud should bottom out in the manifold. Secure the manifold through the top mounting hole with a 3/8" x 3/4" cap screw and 3/8" flat washer.

NOTE: When installing the manifold between the mount brackets on the A-frame, hold the manifold at the sides of the block. Never handle the manifold by the coils. Doing so can cause a solenoid cartridge to bend, causing the cartridge to stick when activated.

NOTE: A medium-strength threadlocking compound should be used on both of the pump mount fasteners.

10. Connect the hydraulic hoses to their respective adapters on the manifold. Hose PN B60273 Port #3; Hose PN B60274 Port #4; Hose PN B60452 Port #2 and Hose PN B60451 (45° angle at manifold end) Port #1. Tighten hoses per torque chart.

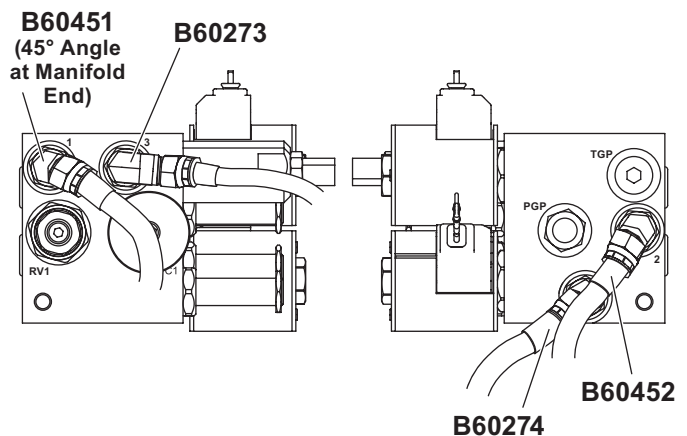

NOTE: Both lift cylinder hoses should be routed through the triangular openings in the A-frame. Position these hoses over the A-frame angle and to their respective manifold ports.

MOLDBOARD & A-FRAME ASSEMBLY

11. Secure the manifold to the A-frame. Align the mount holes with the A-frame brackets. Properly replace and tighten all hardware.

NOTE: A medium-strength threadlocking compound should be used to secure the manifold mount fasteners.

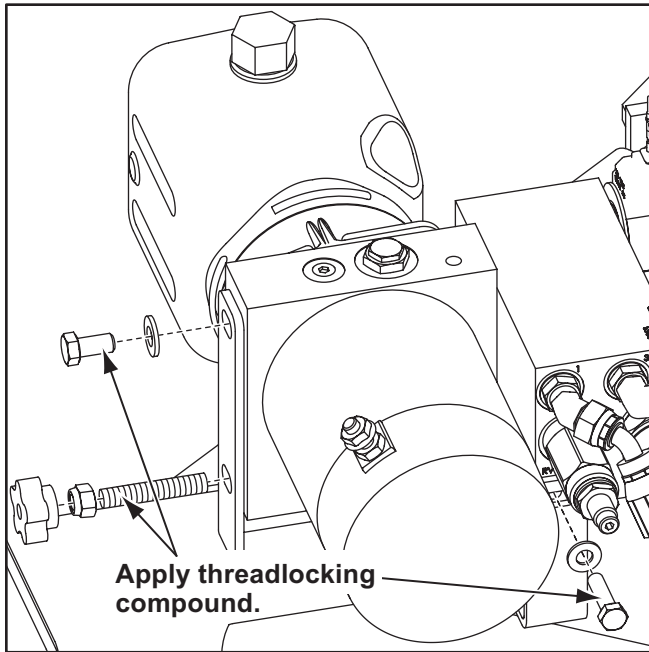

12. Insert the cable through the pivot bushing from center. Pin on A-frame extensions. Slide cable through spring. Add washer and nut. Adjust nuts on cable at full angle so that the wing stops just touch the outside moldboard ribs.

NOTE: Too much adjustment will cause the wings to stop before the snowplow is fully angled and could stretch the cables.

Adjust with snowplow centered, then angle to see if stops are touching. Install and lock in place with jam nut. The blade needs to be operational and installed on the vehicle to complete these adjustments.

13. Hook each extension spring to the receiving holes on the pivot beam and attach the opposite end of the spring to its respective spade bolts. Install the spade bolts through the extension spring mounting angle on the top rear of the blade. Secure each spade bolt by placing one 5/8" flat washer on the bolt and thread one 5/8" locknut. Tighten each locknut until a piece of paper can pass between the third and fourth coils on the spring.

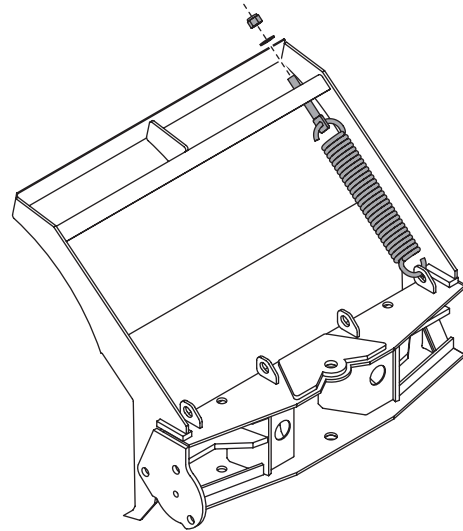

14. Install the blade guides at each end of the moldboard. Insert the cap screw through the holes at the top of the wing reinforcement rib. Tighten all screws with locknuts.

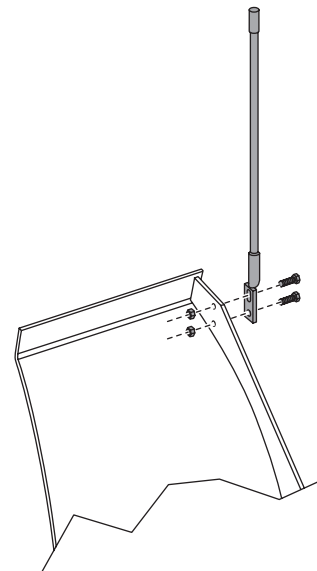

GENERAL SYSTEM SCHEMATICS

ELECTRICAL SCHEMATIC

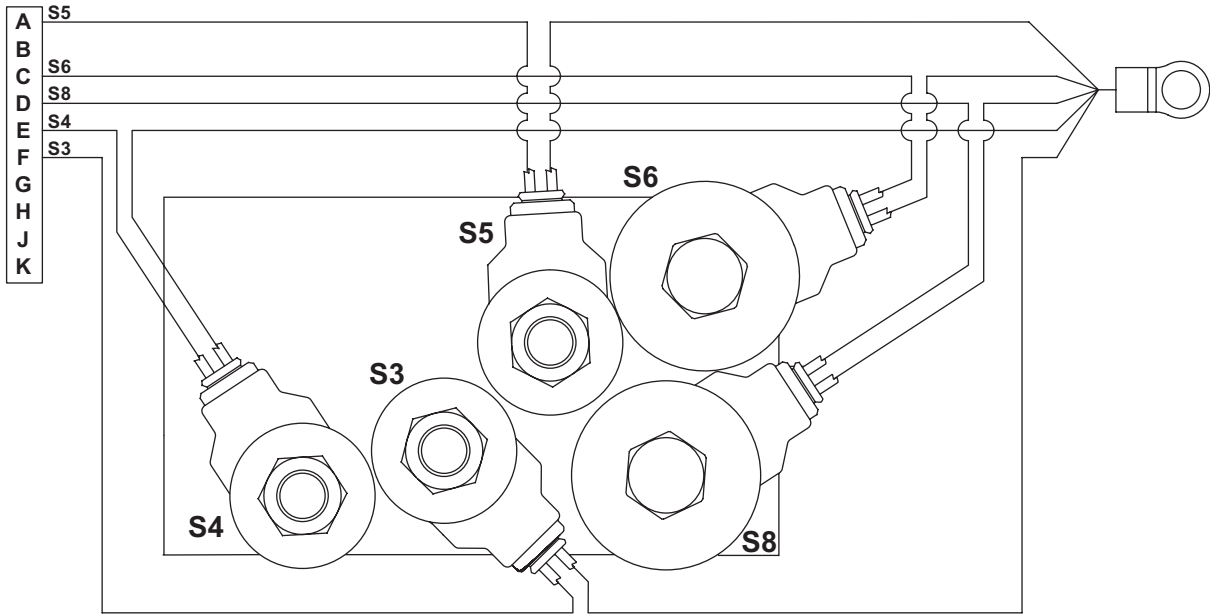

HYDRAULIC SCHEMATIC

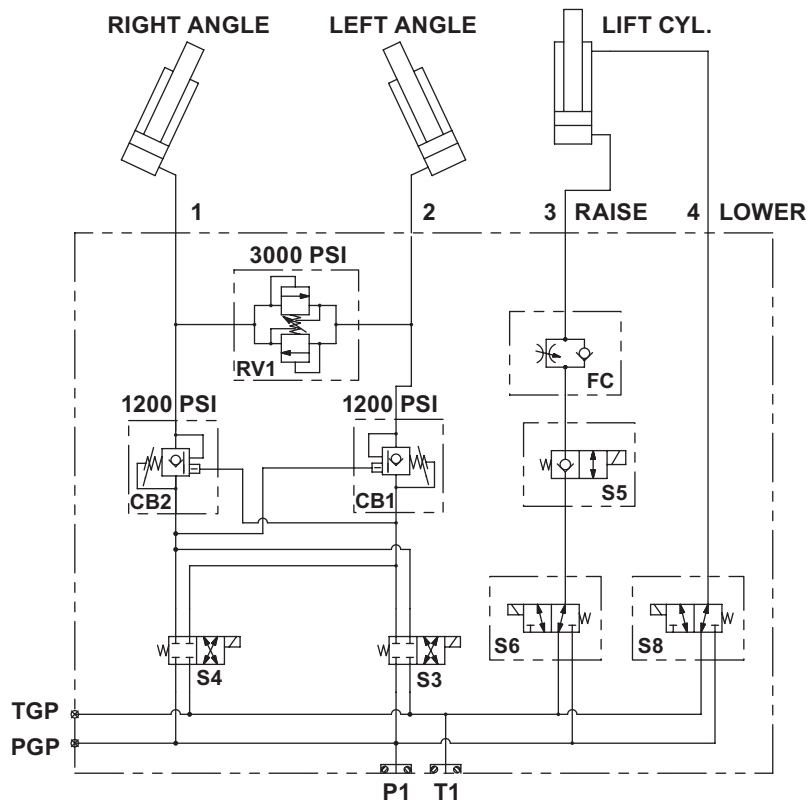

Hydraulic Valve & Hose Port Guide

Models 760sw & 860sw

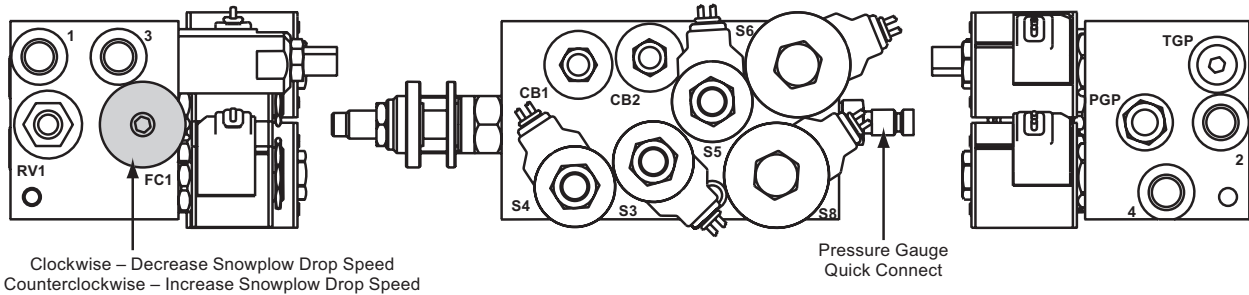

If being used with auxiliary hydraulics, recommended for systems having a flow rated at 4–30 gallons per minute (gpm) and a maximum pressure rating of 3,000 psi.

HYDRAULIC HOSES	
Port	Function
1	Angle Right – Driver-Side Cylinder
2	Angle Left – Passenger-Side Cylinder
3	Raise – Lift Cylinder (Base)
4	Lower – Lift Cylinder (Rod)
RELIEF VALVE	
Valve	Function
RV1	Angle Relief
COUNTER BALANCE VALVES	
Valve	Function
CB1	Angle Right Counter Balance
CB2	Angle Left Counter Balance

VARIABLE FLOW CONTROL VALVE	
Valve	Function
FC1	Snowplow Drop Speed Adjustment
NOTE: Energize the following solenoids for the functions:	
S3	Angle Left – Passenger-Side Cylinder
S4	Angle Right – Driver-Side Cylinder
S5	Float
S6	Raise – Lift Cylinder (Base)
S5 & S8	Lower – Lift Cylinder (Rod)



Milwaukee, Wisconsin 53224

B63185

ELECTRICAL INSTALLATION — SNOWPLOW SIDE

1. Connect the red power wire from the snowplow harness to the pump motor terminal stud. Hardware provided on pump.
2. Place the 3/8" lock washer, the black ground wire (from the harness) and the red ground wire on the coil harness (from the manifold) over the tapped hole on the pump and secure with 3/8" x 3/4" screw.
3. Remove the nut and washer from the POWER HITCH™ connect/disconnect toggle switch and insert it through the back of the mounting bracket on the A-frame. Align the tab on the switch and notch on bracket. Replace the washer and nut and tighten until the switch is firmly in place. Attach the connector on the snowplow harness to the switch.

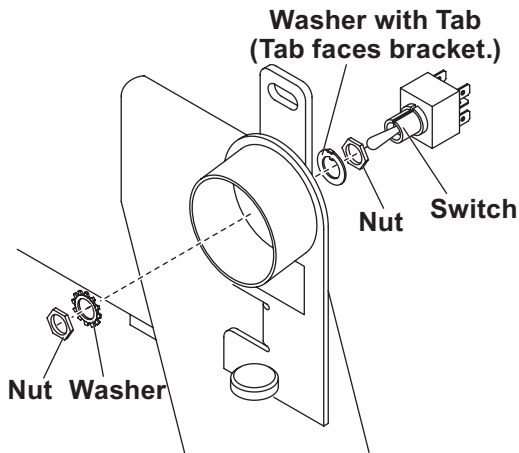

NOTE: Use caution when connecting. Switches can break if this is done forcefully.

4. Attach the connector on the harness to the connector on the coil harness.
5. Position the harness braid in the notch on the switch bracket and secure it with a cable tie.

NOTE: The diode loop harness should be inside of the pump cover.

6. Install the pump and manifold cover by aligning the notches in the cover with the welded bolts on the A-frame brackets. Secure with clamping knob. Verify that the cover is positioned over the protective toggle switch hood. Pop the front of the cover on the threaded stud and secure it with the remaining knob.

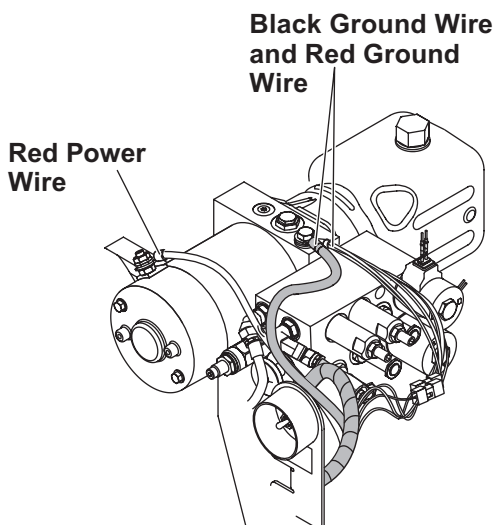
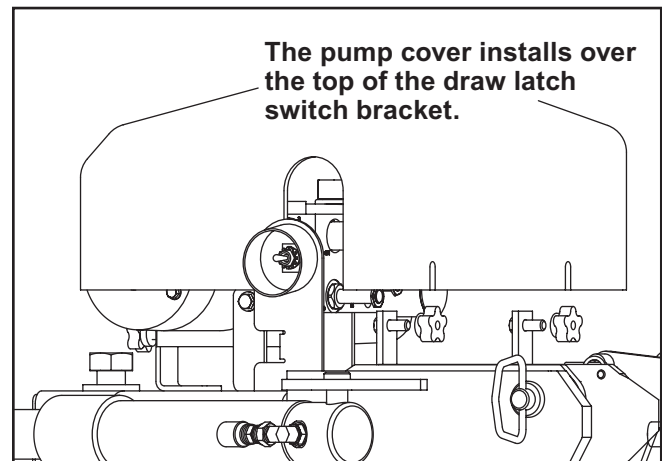

ELECTRICAL SCHEMATICS

BLIZZARD® HARNESS PLUG (VEHICLE) UNIVERSAL 14 + 2 MOLD

PIN NO.	COLOR	FUNCTION	AWG
1	BLACK	GROUND	4
2	BLACK	GROUND	18
3	RED	12 VOLT DC (+)	4
4	BROWN/WHITE	PUMP SOLENOID TO RING	18
5	BROWN	PUMP SOLENOID TO MOLEX	18
6	RED/WHITE	RIGHT SLIDE BOX EXTEND	18
7	RED/BLACK	RIGHT SLIDE BOX RETRACT	18
8	BLUE/WHITE	LEFT SLIDE BOX EXTEND	18
9	BLUE/BLACK	LEFT SLIDE BOX RETRACT	18
10	BLUE	LEFT ANGLE	18
11	LT. GREEN	RIGHT ANGLE	18
12	WHITE	LIFT	18
13	ORANGE	FLOAT	18
14	N/A	N/A	N/A
15	N/A	N/A	N/A
16	N/A	N/A	N/A
17	PINK/BLACK	12 VOLT DC (+) FUSED	18
18	N/A	N/A	18

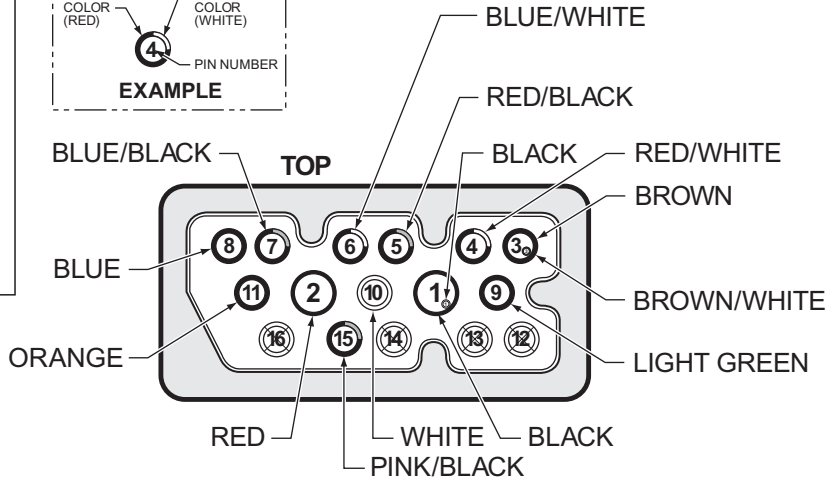
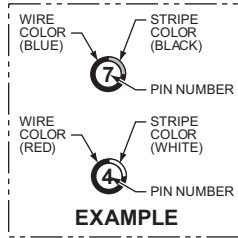
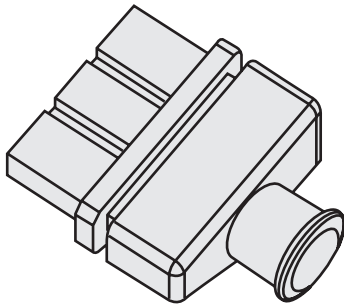

VEHICLE HARNESS PLUG (2005)
FACE VIEW LOOKING AT FEMALE CONNECTOR
FEMALE TERMINALS

BLIZZARD HARNESS PLUG (PLOW)

PIN NO.	COLOR	FUNCTION	AWG
1	BLACK	GROUND	4
2	N/A	N/A	N/A
3	RED	12 VOLT DC (+)	4
4	BROWN	PUMP SOLENOID	18
5	RED/WHITE	RIGHT SLIDE BOX EXTEND	18
6	RED/BLACK	RIGHT SLIDE BOX RETRACT	18
7	BLUE/WHITE	LEFT SLIDE BOX EXTEND	18
8	BLUE/BLACK	LEFT SLIDE BOX RETRACT	18
9	BLUE	LEFT ANGLE	18
10	LT. GREEN	RIGHT ANGLE	18
11	WHITE	LIFT	18
12	WHITE	LIFT	18
13	ORANGE	FLOAT	18
14	N/A	N/A	N/A
15	N/A	N/A	N/A
16	N/A	N/A	N/A
17	PINK/BLACK	12 VOLT DC (+) FUSED	18
18	N/A	N/A	18

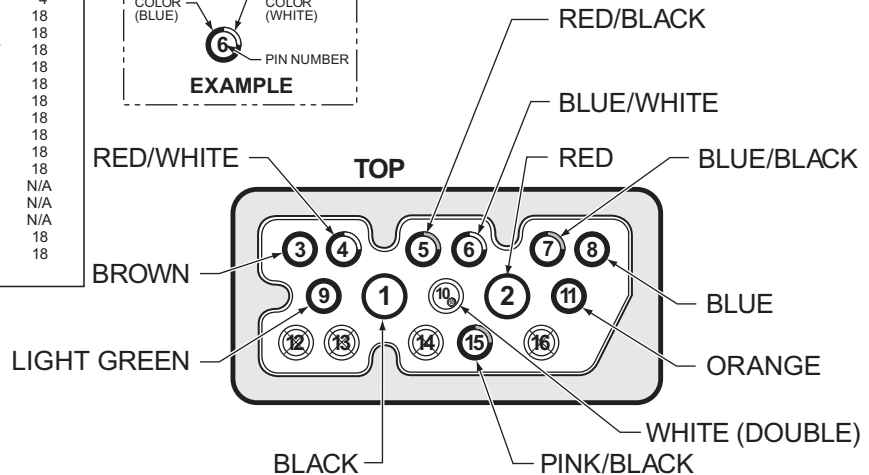
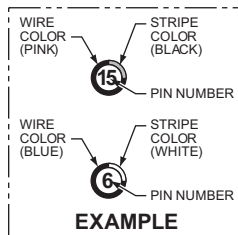
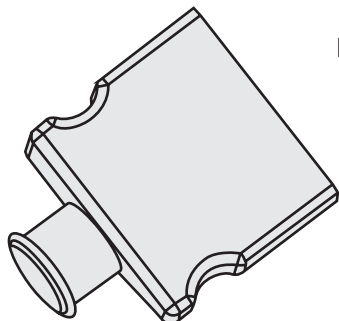

PLOW HARNESS PLUG (2005)
FACE VIEW LOOKING AT MALE CONNECTOR
MALE TERMINALS

ELECTRICAL SCHEMATICS — SNOWPLOW SIDE

PLOW HARNESS (B62039)

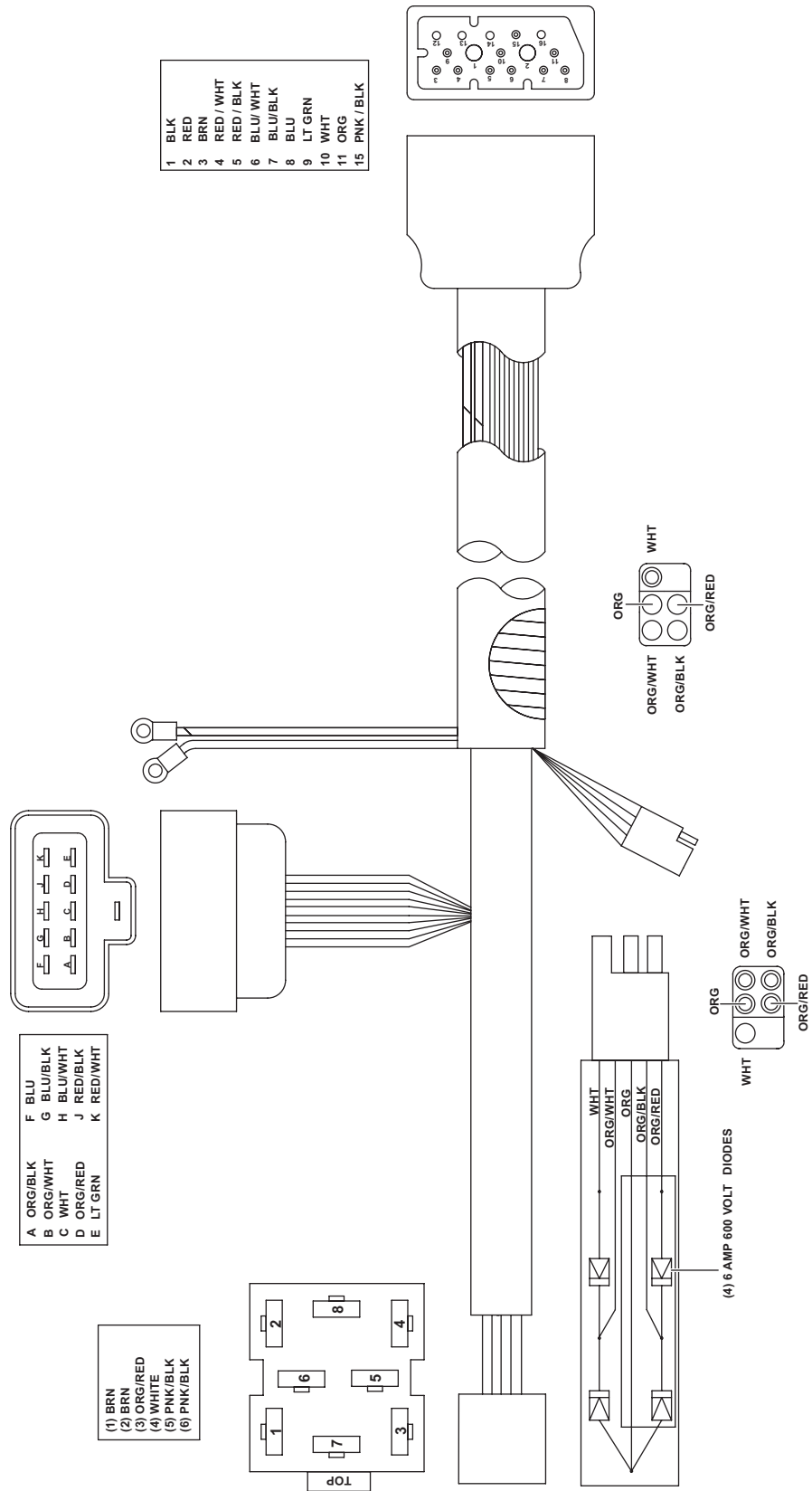

ELECTRICAL SCHEMATICS — SNOWPLOW SIDE

PLOW WIRE HARNESS SCHEMATIC (B62039)

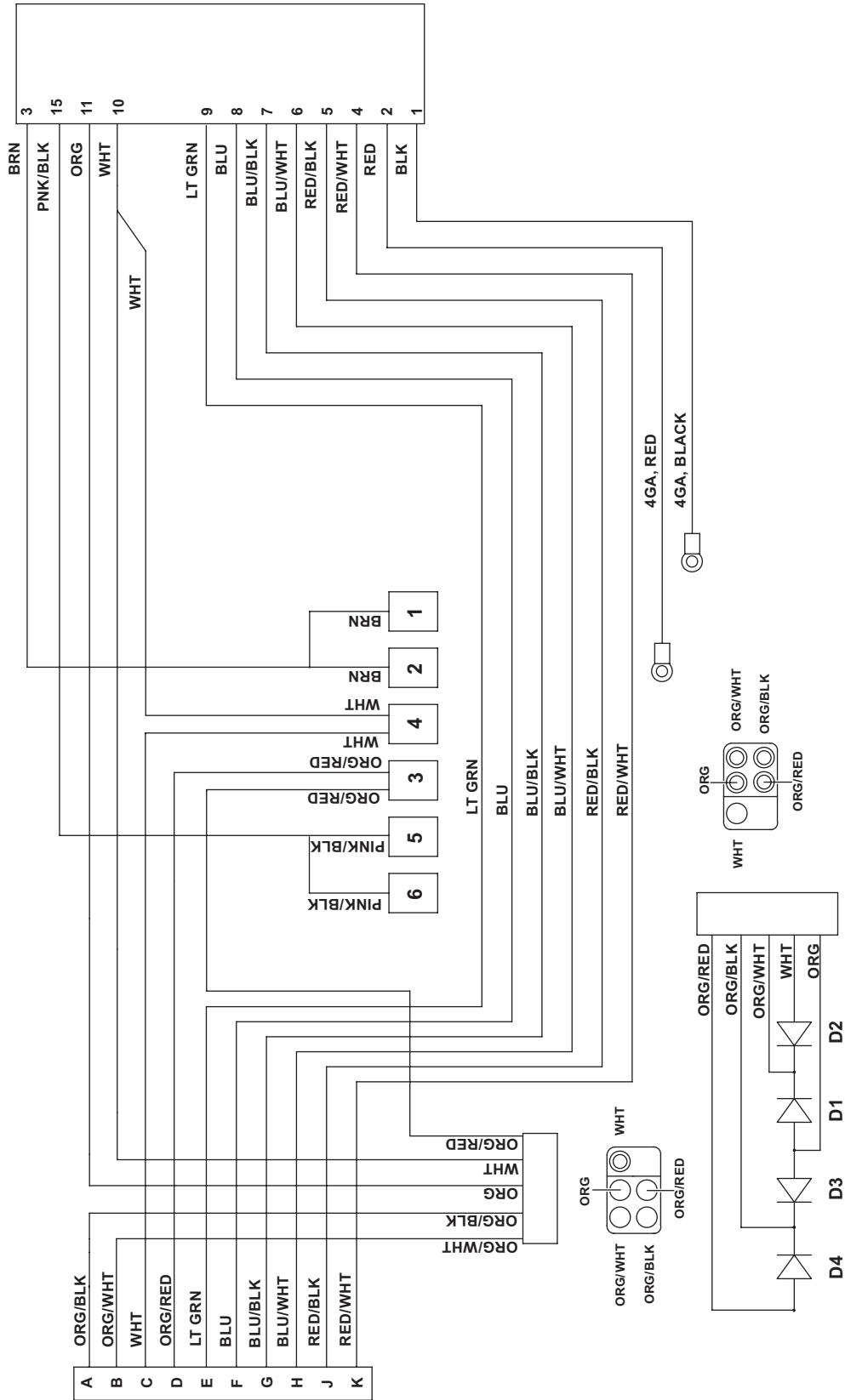

ELECTRICAL INSTALLATION — VEHICLE SIDE

⚠ CAUTION

Before drilling any holes, check the selected area for wires, hoses or other obstructions.

1. With the large plug on the electrical harness placed near the tow hook, under the bumper, route the harness over the driver-side fender well and to the fire wall. Insert the connector end of the harness through an existing hole in the fire wall and into the vehicle cab. If an access hole does not exist, drill an appropriately sized hole through the fire wall in a convenient location away from sharp edges and hot or moving parts.

NOTE: Keep the snowplow plug and vehicle connector pins lubricated with a liberal amount of dielectric grease. Always replace the protective weather caps when the snowplow is disconnected from the vehicle.

2. Attach the power contactor (solenoid) to the driver-side wheel well or engine fan guard using #12 x 3/4" self-drilling screws.

NOTE: Some model vehicles provide mounting locations for accessory components.

Always mount the solenoid with the terminals facing up, for extended solenoid life. Connect the 24" black ground wire to either small terminal on the solenoid and attach the opposite end to the vehicle with a self-drilling screw. Cut the brown/white pump activation wire on the harness

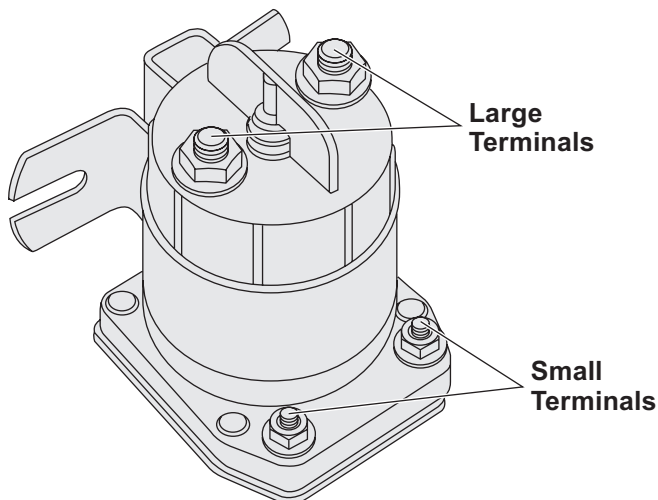

(860SW solenoid shown)

to length. Strip the end of the harness and crimp the eyelet terminal onto it. Attach the eyelet to the remaining small terminal on the contactor. Secure it with the hardware provided on the solenoid.

NOTE: Do not fasten the harness to areas that come in contact with moving engine parts or become extremely hot. The harness could become tangled and/or melt causing electrical failure and vehicle damage.

3. Connect the vehicle harness ground wire to the NEGATIVE (-) terminal on the vehicle's battery. Cut the wire to length and strip the end of the wire. Crimp and solder a 3/8" ring terminal on the wire.

NOTE: The harness should be secured to the vehicle prior to taking the necessary measurement.

Measure the distance needed for the power wire to reach the solenoid. Strip the wire, then crimp and solder an end ring terminal to it. Connect the power wire to either large terminal on the solenoid.

4. Strip both ends of the remaining length of red wire, then attach and solder an end ring terminal to both. Connect one end of the wire to the open terminal on the solenoid and the remaining end to the POSITIVE (+) terminal on the battery.
5. Position the main lighting harness with both of the truck headlamp connectors near each truck headlamp and the snowplow headlamp connectors near the grille of the vehicle.
6. Plug the headlamp ground/relay connector from the vehicle harness into the connector on the main lighting harness. Securely mount the relay receptacles to the vehicle with the terminal wires facing down and the relays facing up. Installing the relays in this position will allow moisture to drain from the relay.
7. Remove the front signal lamp assembly from both sides of the vehicle. On the driver's side, feed the

ELECTRICAL INSTALLATION — VEHICLE SIDE

violet (turn lamp) and gray (run lamp) wires from the main lighting harness through the opening in the signal lamp housing. Use a test light or ohmmeter to determine the proper wires in the vehicle's electrical system to splice into. Position one end of the turn or run lamp wire into the splice lock connector, and attach the vehicle wire into the opposite side. Complete the splice by pinching both wires together and locking the connector. Repeat the splice procedure for the remaining wire.

8. Repeat Step 7 for passenger's side, using the pink (turn lamp) and gray (run lamp) wires.
9. Connect the vehicle headlamps to the main lighting harness using a light conversion harness kit. Due to differences in the construction of the kits, and the various make and model vehicles BLIZZARD® snowplows are installed on, a light conversion kit is not packaged with your snowplow. Contact your local BLIZZARD dealer to obtain the appropriate conversion harness kit for your vehicle.
10. Secure the braided harness to the vehicle. Safely route all harnesses around the engine components and attach them to the vehicle with cable ties. Extend the snowplow headlamp connectors from the main lighting harness, through the grille of the vehicle, and position the harness power plug and weather cap near the bumper. Cable tie the plug to the vehicle bumper or tow hook to keep the harness from hanging too low.

⚠ CAUTION

Do not alter, modify or install additional components in shaded areas of the following illustration. Failure to comply may interfere with air bag deployment or cause injury to operator in an accident.

11. Install the remainder of the vehicle wire harness to the interior of the cab. Find an accessible location for the snowplow headlamp toggle switch and bracket under the dashboard. When choosing a location for your switch, it should be mounted

in easy reach of the vehicle operator and not restricting access to vehicle controls or vehicle instrumentation. Do not mount the switch in areas prohibited by the vehicle manufacturer for crash worthiness. See the vehicle's body builder's book, owner's manual or service manual for details. The shaded areas in the illustration below show the most commonly restricted areas.

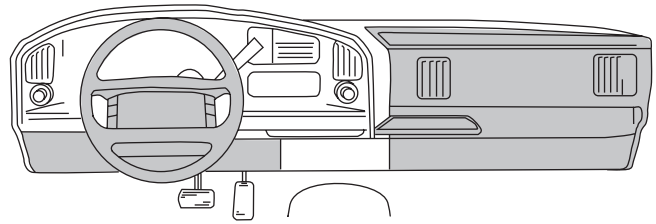

Install the headlamp bracket using two self-drilling screws. Insert the toggle switch through the bracket and secure it with the hardware provided. Plug both of the switch leads into the toggle switch.

NOTE: Both terminals should be inserted into the spades on the same side of the switch. One terminal should be positioned in the middle spade.

Plug both 2-pin connectors together, and this will connect the toggle switch to the vehicle wire harness. See illustration below.

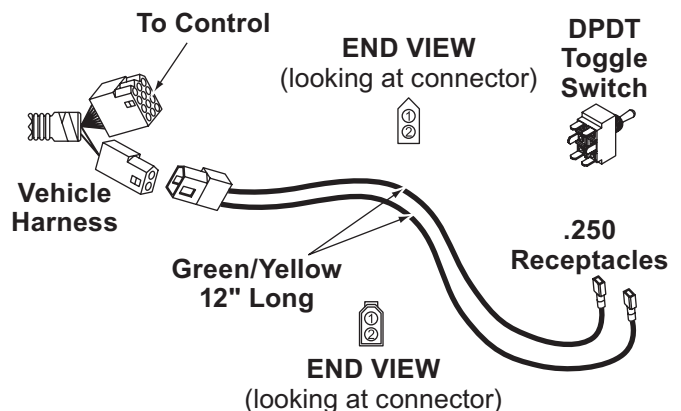

ELECTRICAL INSTALLATION — VEHICLE SIDE

- Connect the power wire (with 15-amp fuse) to a switched power source with a minimum of 15 amps.

NOTE: The red power wire MUST be fused and switched ON and OFF with ignition.

Secure all loose wires under the dash.

- Install the light tower. Position the arms into the receiving pockets located on the undercarriage. Each pocket has a lock pin that secures both light tower arms. Pull out and twist each handle to temporarily unlock the pins. Place the light tower into the pockets and relock the pins. See your local BLIZZARD® dealer for complete installation instructions for your vehicle undercarriage.
- Install the snowplow headlamps. Align one headlamp stud on the light tower tube with the mounting hole and insert the threaded stud through each. Secure the headlamp with one 1/2" galvanized washer (neoprene facing up), one 7/16" external tooth lock washer and locknut.

NOTE: All snowplows are shipped with two caps that install on the ends of the light tower.

After adding a liberal amount of dielectric grease, connect the terminals from the snowplow headlamps to the terminals on the main lighting harness.

- If using a joystick control**, align the mount holes on the joystick control with the holes located on the mount pedestal.

NOTE: The radius on the pedestal should face the dashboard.

Secure the joystick to the pedestal with the #8 x 3/4" machine screws provided. Slide the hook-and-loop fastener strap through the slots cut in the pedestal. The D-ring should be located on the side opposite of the radius. Wrap the strap around the bench and fasten.

- Connect the white power connector from the vehicle wire harness to the connector on the control station. The power switch should be in the "OFF" position.

NOTE: The operation of the draw latch can only be controlled when the switch on the control is in the "POWER HITCH™" position and the "RAISE/LOWER" rocker switch on the A-frame is in the neutral (center) position.

- After completing the mechanical and electrical installations, test all snowplow and lighting functions before attempting to drive or plow.

Joystick Control

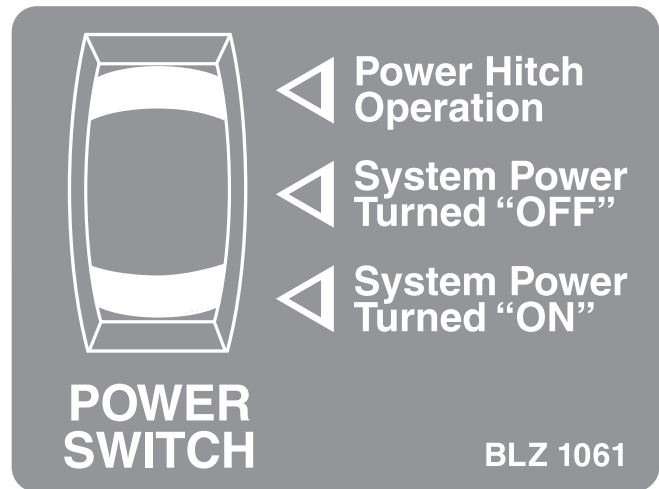

Touchpad Control

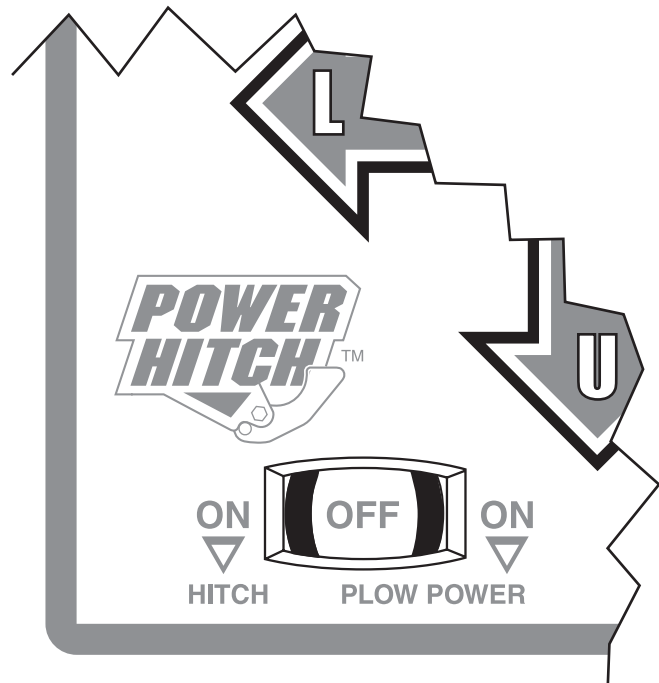

ELECTRICAL SCHEMATICS — VEHICLE SIDE

VEHICLE HARNESS (2005)

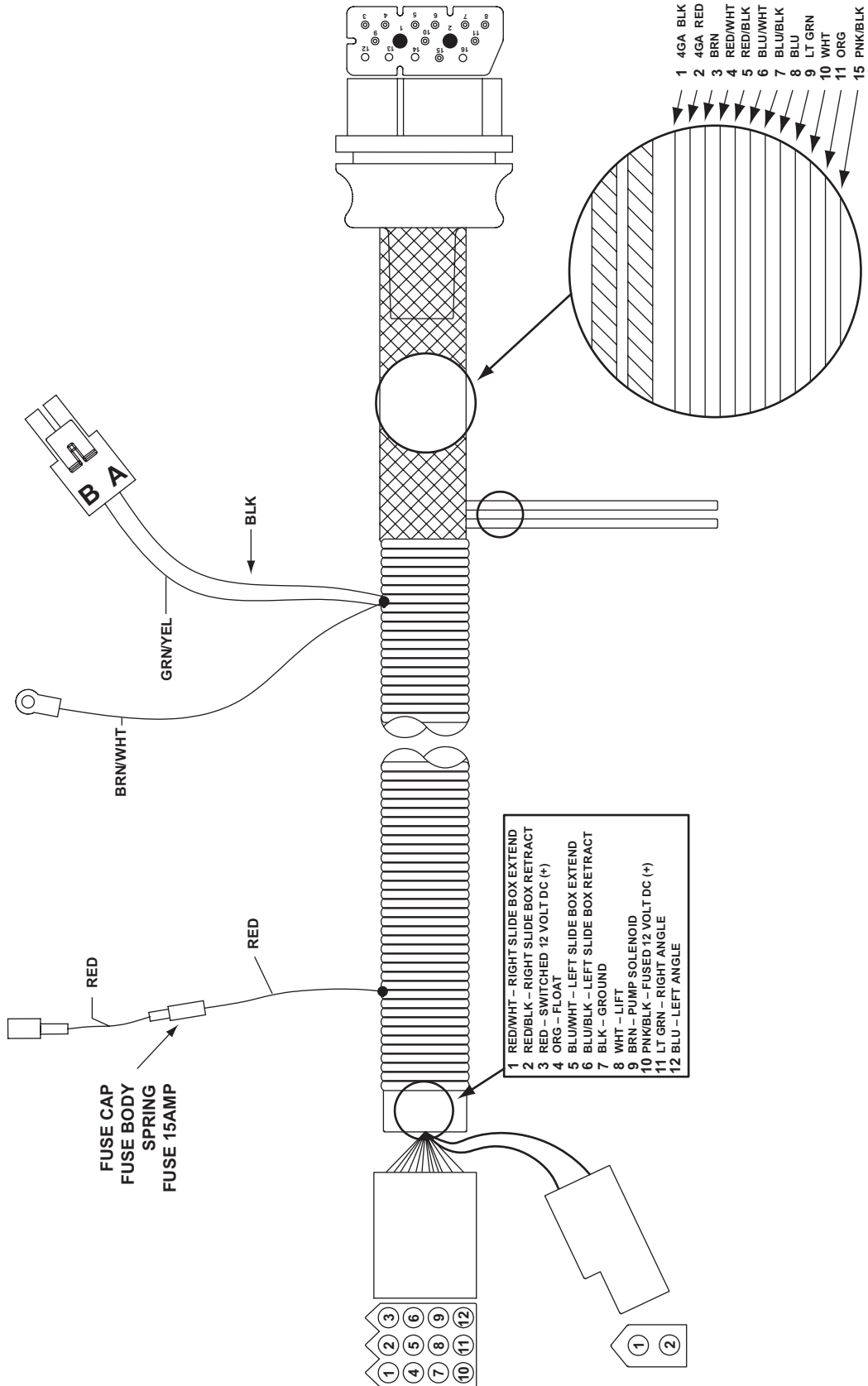

ELECTRICAL SCHEMATICS — VEHICLE SIDE

VEHICLE HARNESS SCHEMATIC (2005)

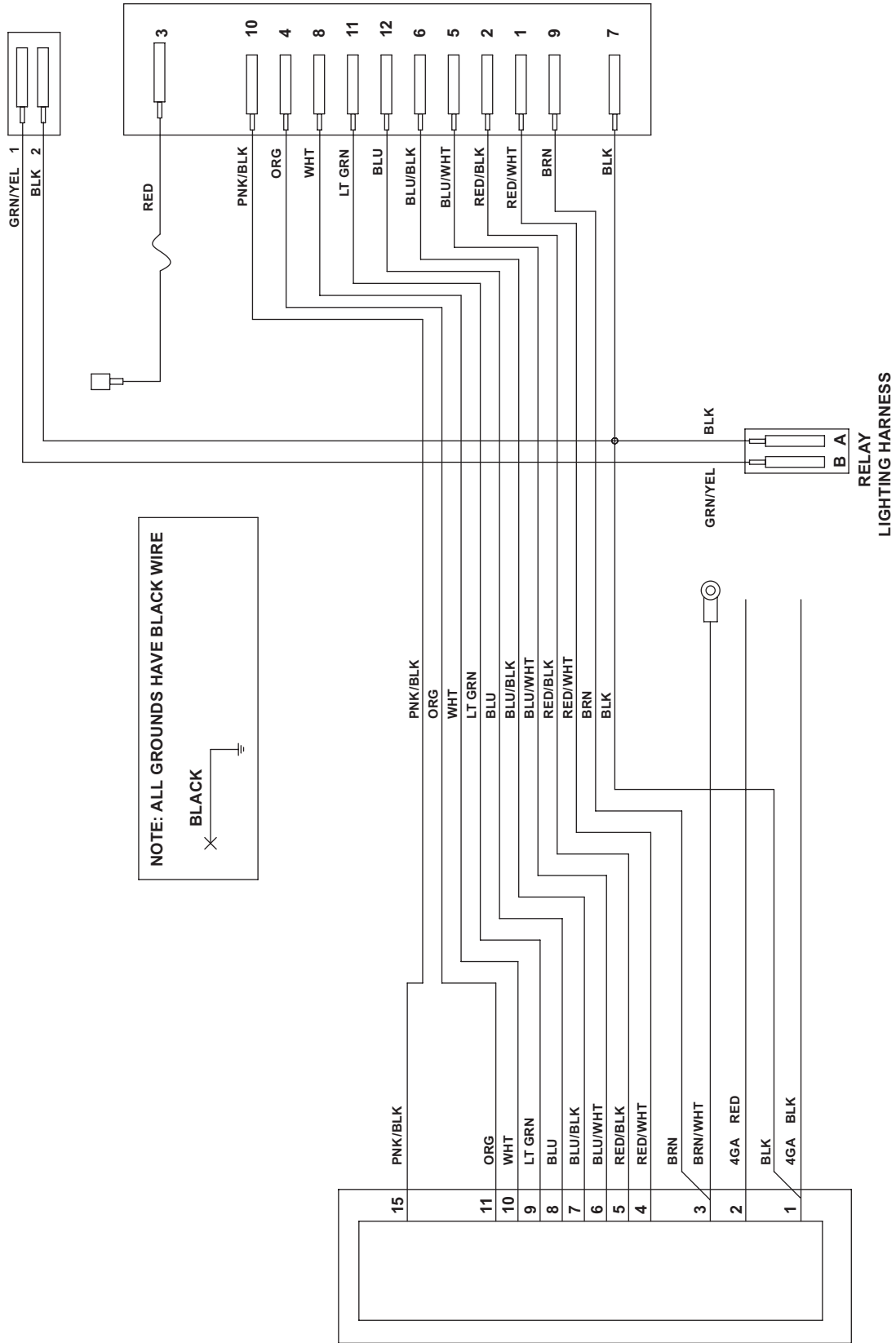

ELECTRICAL SCHEMATICS — VEHICLE SIDE

MAIN LIGHTING HARNESS (2005)

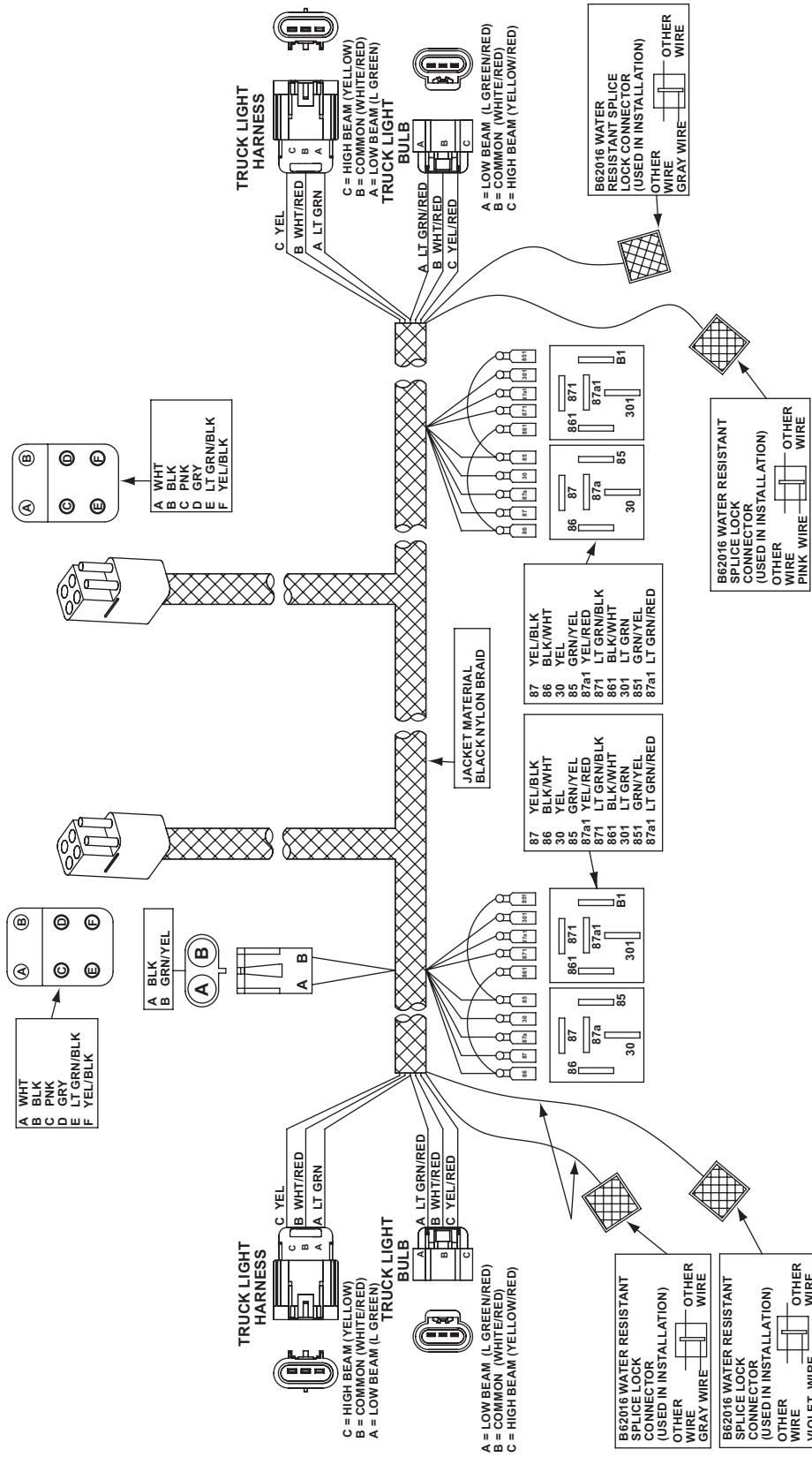

ELECTRICAL SCHEMATICS — VEHICLE SIDE

MAIN LIGHTING HARNESS SCHEMATIC (2005)

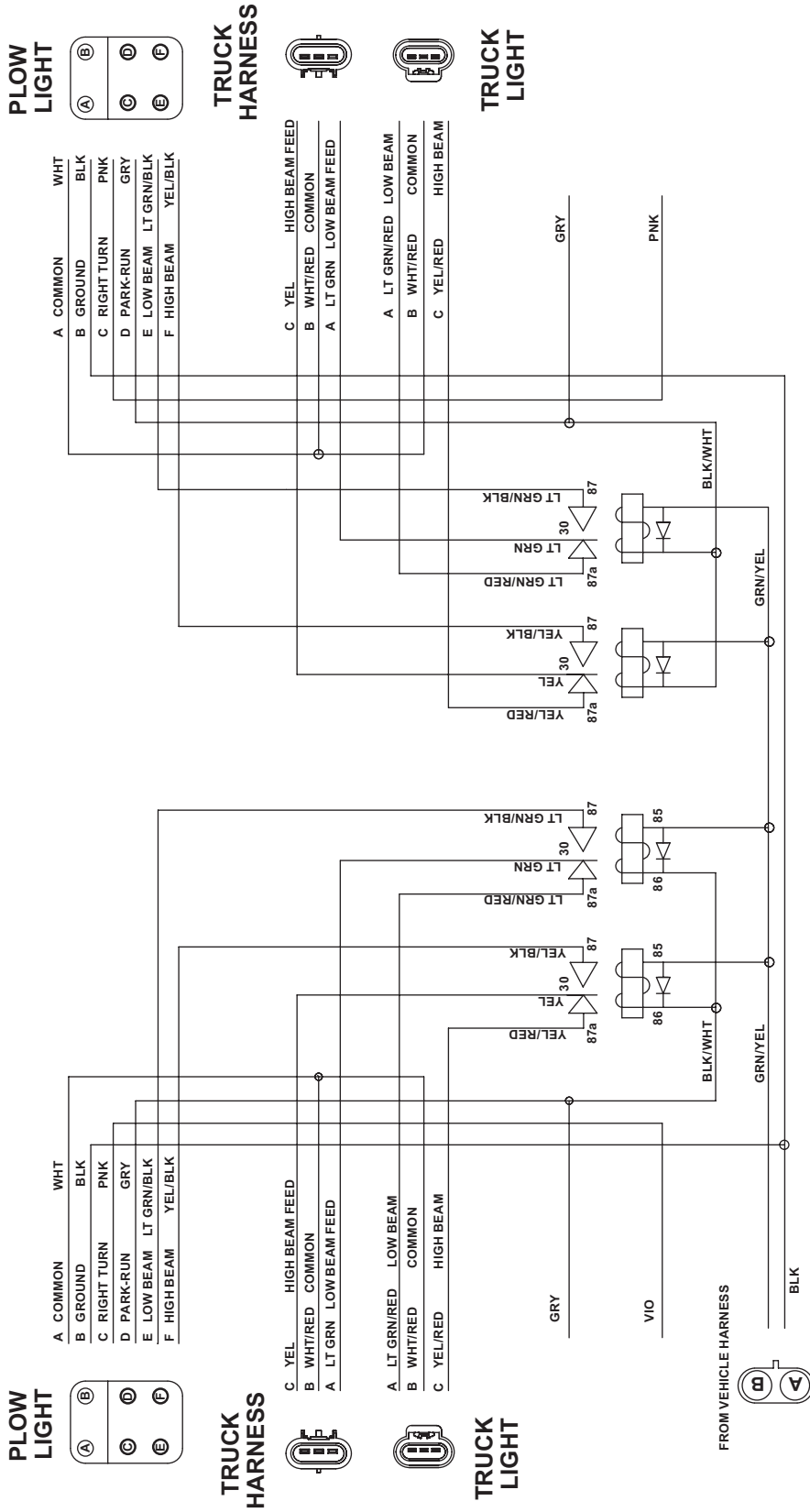

POWER HITCH™ SYSTEM INSTRUCTIONS

Prior to operating your SPEEDWING™ snowplow, review the Mount and Dismount Instructions label on the back of the driver-side moldboard.

NOTE: If at any time the Mount and Dismount Instructions label, or any other label attached to your snowplow, becomes illegible, promptly replace it.

MOUNT INSTRUCTIONS		DISMOUNT INSTRUCTIONS	
Read Owner's Manual for Complete Instructions.		Read Owner's Manual for Complete Instructions.	
<p>STEP #1</p>		<p>STEP #1</p>	
<p>⚠ WARNING: Keep fingers away. POWER HITCH arm raises behind undercarriage pushbeam.</p>			
<ul style="list-style-type: none"> • Kickstand must be lowered, with kickstand pin seated in lower hole on pivot beam. • Slowly drive vehicle forward until pushbeam receiver mount points contact A-frame mount bushings. • Turn POWER HITCH OPERATION switch (on plow control) to "ON" position. • Connect plow and vehicle electrical harnesses. Connect weather caps together. 		<ul style="list-style-type: none"> • Raise plow. Lower kickstand until kickstand pin is seated in lower hole on pivot beam. • Lower plow on flat, level surface. Turn vehicle ignition off. • Remove hitch pins from A-frame and undercarriage. • Turn vehicle ignition on. • Turn POWER HITCH OPERATION switch (on plow control) to "ON" position. 	
<p>STEP #2</p>	<p>STEP #2</p>		
<p>⚠ WARNING: Keep fingers away from plow and truck mounting points.</p>			
<ul style="list-style-type: none"> • Pull A-frame latch lock pin out and lower A-frame latch over draw pin. • Push and hold CONNECT/DISCONNECT switch upward. POWER HITCH arm will engage back of pushbeam and pull plow into pushbeam receiver mount points on vehicle. • Insert both hitch pins and secure each with hair pin cotter. • Lower POWER HITCH arm to relieve tension on A-frame latch. Raise A-frame latch and lock into position with lock pin. Raise plow. • Raise kickstand until kickstand pin seats into upper hole on pivot beam. 		<ul style="list-style-type: none"> • Push and hold CONNECT/DISCONNECT switch downward. POWER HITCH arm will disengage from behind undercarriage pushbeam and lower. • Disconnect plow and vehicle electrical harnesses. Install weather caps. • Turn SYSTEM POWER (on plow control) to "OFF" position. • Slowly move vehicle backward away from plow. 	
<p><small>U.S. Patents 5,638,618; 5,899,007; 6,178,669; 6,276,076; 6,393,737; 6,408,549; 6,412,199; 6,442,877; 6,615,513; Canadian and other patents pending.</small></p>			
			44812

TESTING YOUR SNOWPLOW

1. Fill the hydraulic pump reservoir with BLIZZARD® Snowplow Rapid Action Hydraulic Fluid until it is approximately 3/4" from the top of the tank. Replace the cap on the reservoir. Remove the weather caps from each of the snowplow and vehicle harnesses and connect the plugs. Start the vehicle and turn the power switch on the control station in the cab to the "ON" position.

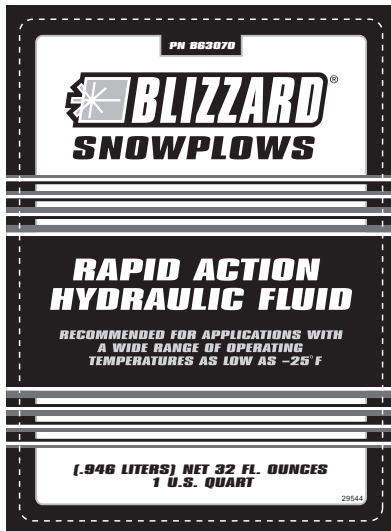

⚠ WARNING

You can die or be seriously injured. Keep hands and feet away from hitch mechanism and snowplow blade when operating the POWER HITCH™ arm. The action of the arm moves the snowplow toward the vehicle and into position for proper attachment.

2. To raise the POWER HITCH arm on the snowplow, turn the power switch on the control station to the "UP" or "ON" position. Push and hold the toggle switch on the A-frame upward into the "CONNECT" position. Notice the action of the fluid in the reservoir. By activating the initial hydraulic function, the fluid begins to fill the system. Push and hold the toggle switch in the "DISCONNECT" position, the POWER HITCH arm will lower. Refill the reservoir until the fluid is approximately 3/4" from the top of the tank.

3. Align the POWER HITCH arm on the A-frame below the pushbeam, with the receiver plates in line with the receiver plates on the undercarriage. Pull out the A-frame latch pin and rotate the A-frame latch clockwise until the latch is resting on the draw pin. Move the snowplow in position by activating and releasing the POWER HITCH connect switch.

The POWER HITCH arm will rise until it hits the pushbeam and the draw latch fingers will pull the snowplow into the vehicle. The receiver plates on the snowplow and vehicle are now positively aligned. Insert the two hitch pins through the mounting holes on the A-frame and secure each with one hairpin cotter.

After the two hitch pins are inserted through the A-frame, lower the POWER HITCH arm using the toggle switch on the A-frame. Rotate the A-frame latch counterclockwise until the A-frame latch lock pin can be reinserted. Fully reinserting the A-frame latch lock pin will lock the A-frame latch in place for transport or plowing snow. (See below.)

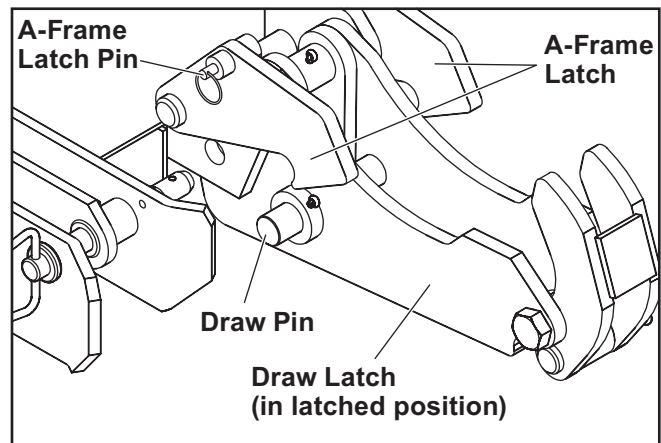

TESTING YOUR SNOWPLOW

- Return to the interior of the vehicle to test the remaining functions of the snowplow. The system power on the control should be in the "ON" position. Raise the snowplow to its maximum height by pulling the joystick back (or down) or pressing the U button on the touchpad. Angle the snowplow to the left by moving the joystick toward the "L" (left angle) on the label or pressing the L button on the touchpad. If the snowplow function is slow or delayed, the hydraulic fluid is filling the cylinder and replacing the air in the system. Test the remaining functions of the snowplow. To lower the snowplow to the ground, push the joystick ahead (or up) or push the D button on the touchpad.

NOTE: The FLOAT function is activated when the joystick is pushed ahead (or up) into the "LOWER" position or the D button is pressed on the touchpad and held there for an additional .5 second after the blade contacts the ground. The LED FLOAT light (touchpad only) will come ON when the snowplow is in FLOAT mode.

Angle the snowplow to the right by moving the joystick toward the "R" (right angle) on the label or pressing the R button on the touchpad. Check the fluid level in the reservoir and fill to 3/4" from the top of the tank if needed.

- Check for fluid leaks around the manifold, pump, hydraulic hoses and all cylinders. If there are any leaks, turn OFF the power switch on the control and shut OFF the vehicle engine. Tighten any loose connections and/or fittings. Restart the vehicle, cycle all blade controls, then check to see if all the leaks have been stopped after turning OFF the control power switch and shutting OFF the vehicle.
- Check that the vehicle and snowplow headlamps are in proper working condition, including the turn signals.

(No LED Float Light or Indicator Light)

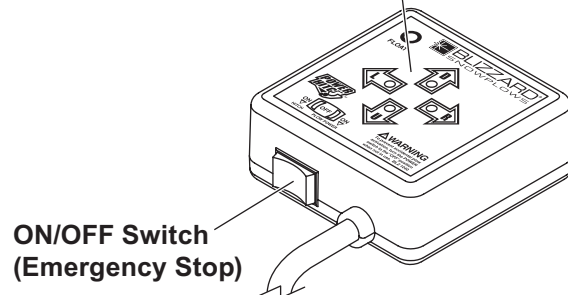
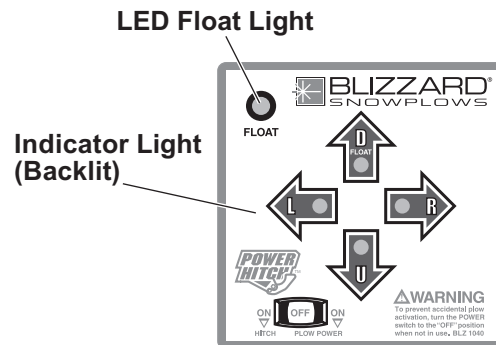
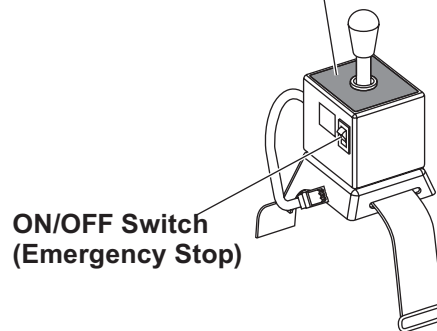
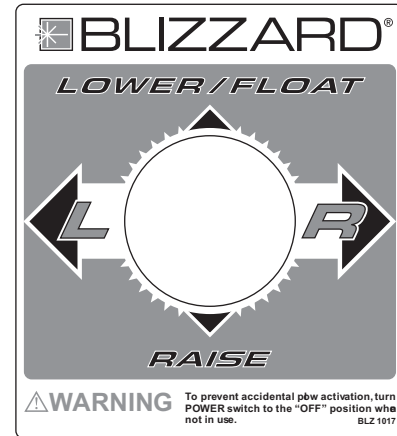

HEADLAMP AIMING

Fully tighten headlamp fasteners once correct visual aim is achieved.

1. Place vehicle on a level surface 25 feet in front of a matte-white screen, such as a garage door. The screen should be perpendicular both to the ground and to the vehicle centerline.
2. The vehicle should be equipped for normal operation. The snowplow blade should be in place and in raised position. Below are steps listed by the Society of Automotive Engineers (SAE) pertinent to headlamp aiming in specification #SAE J599d.
3. Prepare vehicle for headlamp aim or inspection. Before checking headlamp aim, the inspector will:
 - a. Remove ice or mud from under fenders.
 - b. Set tire inflation pressures to the values specified on vehicle information label.
 - c. Check springs for sag or broken leaves.
 - d. See that there is no load in the vehicle other than the driver and ballast as specified in the Undercarriage Selection Guide.
- e. Check functioning of any automatic vehicle leveling systems and specific manufacturer's instructions pertaining to vehicle preparation for headlamp aiming.
- f. Clean lenses.
- g. Check for bulb burnout and proper beam switching.
- h. Stabilize suspension by rocking vehicle sideways.
4. Mark (or tape) the vertical centerline of the snowplow headlamps and the vertical centerline of the vehicle on the screen. Mark the horizontal centerline of the snowplow headlamps on the screen (distance from ground to snowplow headlamp centers).
5. Align the top edge of the high-intensity zone of the snowplow lower beam below the horizontal centerline and the left edge of the high-intensity zone on the vertical centerline for each snowplow headlamp. (Refer to diagram below.)

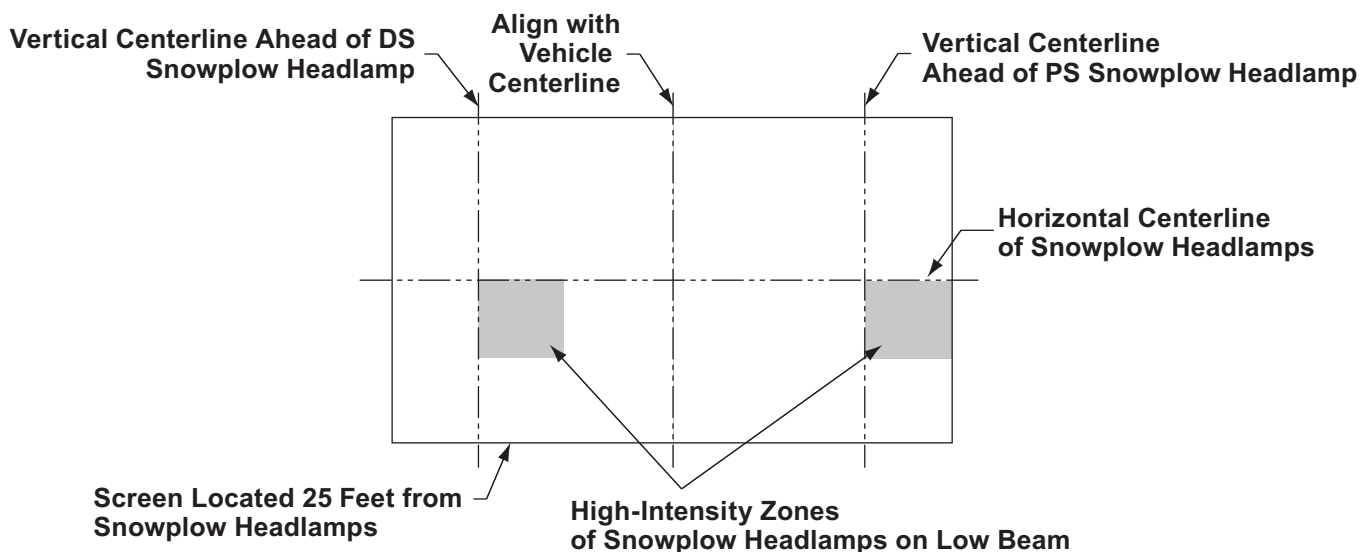

MAINTENANCE

Maintenance	Periodically	Yearly
Check fasteners for tightness. Torque to specifications.	X	
Check hoses for wear and leaks.	X	
Check cylinders for leaks; inspect rod ends for corrosion and pitting.	X	
Check cables for wear or fraying.	X	
Lubricate all exposed cylinder rod ends with liquid white lithium grease to prevent corrosion.		X
Check cutting edges and plow shoes for wear. <i>NOTE: Do not discard plow shoe washers; these should be retained for different shoe adjustments.</i>	X	
Clean and lubricate all electrical plugs and connections with dielectric grease. Clean and install all dust caps prior to storing.	X	X
Lubricate all pins and bushings and A-frame latch with NLGI Grade 2 multipurpose lithium complex grease with molybdenum (MPGM) to maintain consistent operation.	X	X
Clean and paint all scratches or exposed metal with BLIZZARD® touch-up paint.	X	X
Check the hydraulic fluid level. Fill with fluid to 3/4" from the top of the reservoir. Do not exceed this level. Never mix different types of fluid.	X	
Remove and properly discard the fluid from the pump reservoir. Clean the pump filter and replace the hydraulic fluid to within 3/4" from the top of the reservoir. Changing the fluid annually will prolong the life of your pump and manifold. Never mix different types of hydraulic fluid.		X
Check the trip spring adjustment. Properly adjusted tension will allow a sheet of paper to pass between the third and fourth coils of the spring.	X	
Clean snow and ice build-up from the pump and manifold cover.	X	
Pressure wash and dry the entire snowplow prior to storing.		X
Cover the snowplow with a tarp if stored outside. This will protect your snowplow from sun fading and inclement weather, which can lead to accelerated corrosion.		X

REMOVING FROM STORAGE

1. Perform all regular maintenance.
2. Replace the hydraulic fluid in the pump reservoir. Prolonged storage could result in condensation build-up.
3. Follow the mounting procedure on the POWER HITCH™ label.
4. Initiate all of the functions. Monitor the fluid level in the reservoir and fill to 3/4" from the top of the tank as necessary.
5. Adjust the snowplow headlamps as needed.

LIFTING

To lift and move this snowplow, attach chain fall grab hooks to outside pivot beam area shown. Always follow recommended lift warnings and procedures. See following page for snowplow weights and dimensions.

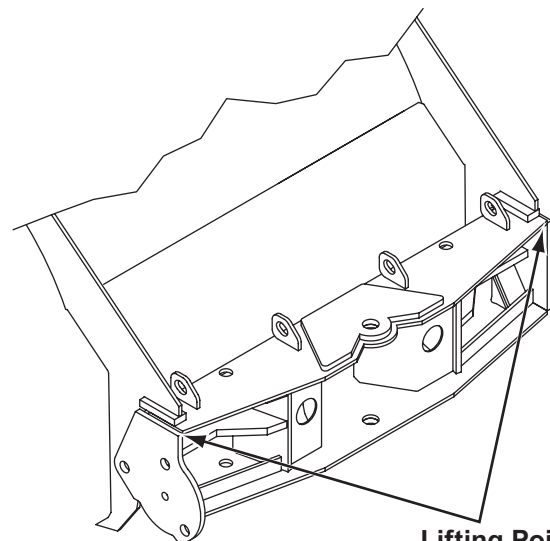

**Lifting Points
(both sides)**

TECHNICAL SPECIFICATIONS

Part	Specification	760SW	860SW
Moldboard	Length	92" (7'-6")	102" (8'-6")
	Thickness	12 ga	
	Height	25-1/2"	29-1/2"
	Reinforcement	4 Ribs @ 1/4"	
	Cutting Edge	3/8" x 6"	1/2" x 6"
	Finish	Powder Coat White	
	Trip Mechanism	(3) 3/8" Hooked Extension	(4) 3/8" Hooked Extension
Wings	Length	15-1/2"	17-1/2"
	Thickness	12 ga	
	Height	25-1/2"	29-1/2"
	Reinforcement	2 Ribs @ 3/16"	
	Cutting Edge	3/8" x 6"	1/2" x 6"
	Finish	Powder Coat White	
A-Frame	Material	Rectangular Tube and Channel Type	
	Hitch Pins	3/4" x 6" Yellow Zinc	
	Finish	Powder Coat Black	
Pump	Construction	Steel Housing with Clear Plastic Tank	
	Type	Internal Gear Pump	
	Size	2.5 cc	
	Motor	12V Starter	
	Weight	32 lb	
	Mount	A-Frame Install with Hex Cap Screws	
	Reservoir Capacity	2 qt	
	Controls	Toggle and Rocker Switch/Joystick or Touchpad	
Manifold	Construction	Red Anodized Aluminum	
	Valves	Electro-Hydraulic Cartridge	
Cylinders	Angle Cylinders	2	
	Stroke	9-3/8"	10"
	Ram Diameter	1-3/4"	1-3/4"
	Bore Diameter	2"	2"
	Raise/Lower Cylinders	1	
	Stroke	4-5/8"	
	Ram Diameter	1-1/4"	
Bore Diameter	2-1/2"	3"	
Snowplow Headlamps	Type	Low-Profile with Turn Signals	
	Measurements	12"W x 5"H x 5-1/4"D	
	Housing	Plastic Composite	
	Bulb Type	High/Low Sealed Beam Halogen 12V Rectangular	
	Switch Type	Dash Mount, Toggle	
Snowplow Specs	Weight*	642 lb	812 lb
	Amperage Draw**	145 A	
	BUCKET BLADE™ Pos. Width	91" (7'-7")	103" (8'-7")
	Angle Width with Trailing Wing	79" (6'-7")	94" (7'-10")
	Back Blade Width	103" (8'-7")	117" (9'-9")
	Adjustable Plow Shoes	(2) Std.	(2) Heavy-Duty Cast Steel
	Mount Mechanism	Hydraulic Power Switch	
Control Station	Joystick or Touchpad		

* Weight does not include undercarriage.

** Amperage Draw specifications are based on snowplow lift operation, at a shop temperature of 65°F, using BLIZZARD® Rapid Action Hydraulic Fluid. Amperage will vary with temperature, fluid viscosity and meter accuracy. Deadheading a snowplow function will result in significantly increased amperage.

TROUBLESHOOTING

Problem	Cause	Solution
Pump will not run.	Snowplow harness may not be properly connected to the vehicle harness.	Verify that the harnesses are properly connected.
	Power or ground cables to the battery, pump or solenoid may not be properly connected.	Properly connect all cables. Clean and lubricate with dielectric grease. If power does not resume, check the continuity of all cables to find the break.
Pump will not run, power to the solenoid.	The black ground wire and brown/white activation wire on the solenoid are not properly connected.	Properly connect both cables. Test for power by initiating any control function except the "FLOAT." <i>NOTE: The POWER rocker switch must be in the "ON" position to properly test any snowplow function.</i> If the solenoid is grounded and no power exists, diagnose the snowplow and truck harnesses.
Pump will not run with power to the solenoid. Brown/white activation wire and ground are properly connected.	The red, hot wire to the pump motor is not properly connected.	Connect red wire and check the black ground wire. If problem is not resolved, the solenoid could be inoperable or the pump motor may be worn. Replace the solenoid if there is no power to the pump. Replace the pump motor if it is receiving power.
Pump will not turn OFF. Do not allow the pump motor to run continuously. Unplug the harness until the solenoid can be tested or a BLIZZARD® outlet can diagnose the problem.	Solenoid may be damaged.	Disconnect the brown/white activation wire from the solenoid. If the problem is not resolved, replace the solenoid.
	Short in the control or wire harness.	Disconnect the control in the cab. If the pump turns OFF, there is a short in the electrical system.
Pump runs but snowplow functions are slow.	Fluid level in the pump reservoir is low. Fluid is leaking.	Add fluid to within 3/4" from the top of the tank. Check for leaks around the pump, manifold and cylinders.
	System pressure may be set too low. Increasing the pressure excessively will increase the amperage draw. This could damage the vehicle harness.	Adjust the pressure. Remove the hex cap on top of the pump and turn the screw clockwise. Proper system pressure should be set at 2400 psi. Test functions and repeat procedure as needed.
	Amperage from the vehicle's alternator is too low.	Repair or replace vehicle alternator. System amperage draw is 145 A at 1500 psi.
	Pump filter may be clogged.	Remove the pump tank and thoroughly clean the filter.
A-frame latch will not move.	Draw latch is binding the A-frame latch.	Lower the draw latch to relieve binding on the A-frame latch and reposition the A-frame latch as needed.
Snowplow will not lift. Pump works properly.	Control station in the cab may not be properly connected.	Connect the power connector from the control to the vehicle harness.
	A-frame latch is in the (down) locked position.	Lift the A-frame latch into the raised position.
	Diode loop harness may be corroded or could have failed.	Clean diode loop harness thoroughly and/or replace.
	Coils on the manifold may be damaged.	Remove the S6 coil from the cartridge valve. Position a screwdriver inside of the coil and push the draw latch connect/disconnect toggle switch upward. The screwdriver should be magnetically drawn to the coil. Replace the coil if there is no action.
Snowplow will not lift with magnification to the S6 coil.	Hydraulic lock in the manifold. This occurs if the voltage is too low on the coils—should be 11.8 volts.	Loosen cartridge valve S6 to relieve pressure and retighten. DO NOT OVERTIGHTEN! Valves should be torqued to a maximum of 24 ft-lb.
	Solenoid cartridge valve may be contaminated.	Remove any foreign objects that may be obstructing proper valve operation. Replace if not operating properly after cleaning.

TROUBLESHOOTING

Problem	Cause	Solution
Snowplow will not stay angled when plowing.	The angle pressure-relief valve is set too low. <i>NOTE: Increasing the pressure-relief setting will cause damage to your snowplow. Do not set the pressure relief greater than 3000 psi.</i>	Check the pressure relief by testing the valve inline with the cylinder. Attach a tee fitting to the angle cylinder hydraulic adapter and connect the hose and pressure gauge to the tee. <i>NOTE: The setting should not exceed 3000 psi.</i>
Snowplow will not angle, pump works.	Review all probable causes above.	<i>NOTE: Verify coils angle functions for S3 and S4.</i>
Snowplow lowers too slowly.	Variable flow control valve is not adjusted properly.	⚠ WARNING: Snowplow can fall suddenly. You can die or be seriously injured. Drop snowplow to ground before adjusting flow control. Turn flow control valve counterclockwise in small increments and test.
	Review all probable causes for "Snowplow will not lift."	Verify S5 coil (float) or S5 and S8 coils (disconnect) for magnetism.
Snowplow drops sporadically.	Variable flow control valve is opened too far.	⚠ WARNING: Snowplow can fall suddenly. You can die or be seriously injured. Drop snowplow to ground before adjusting flow control. Turn clockwise 1/16 turn and test.
Snowplow doesn't return to BUCKET BLADE™ position.	Spring broken or bound.	Check spring for breakage or interference.
Trailing wing not straight when snowplow angled.	Wing doesn't come back to the stop.	Adjust cable(s).
Headlamps will not switch from the vehicle to the snowplow.	No power or ground to the headlamp relay.	Verify that the headlamp/ground relay connector is connected. If the connector is properly attached, replace the headlamp relay(s).

MOLDBOARD & WING PARTS — ALL MODELS

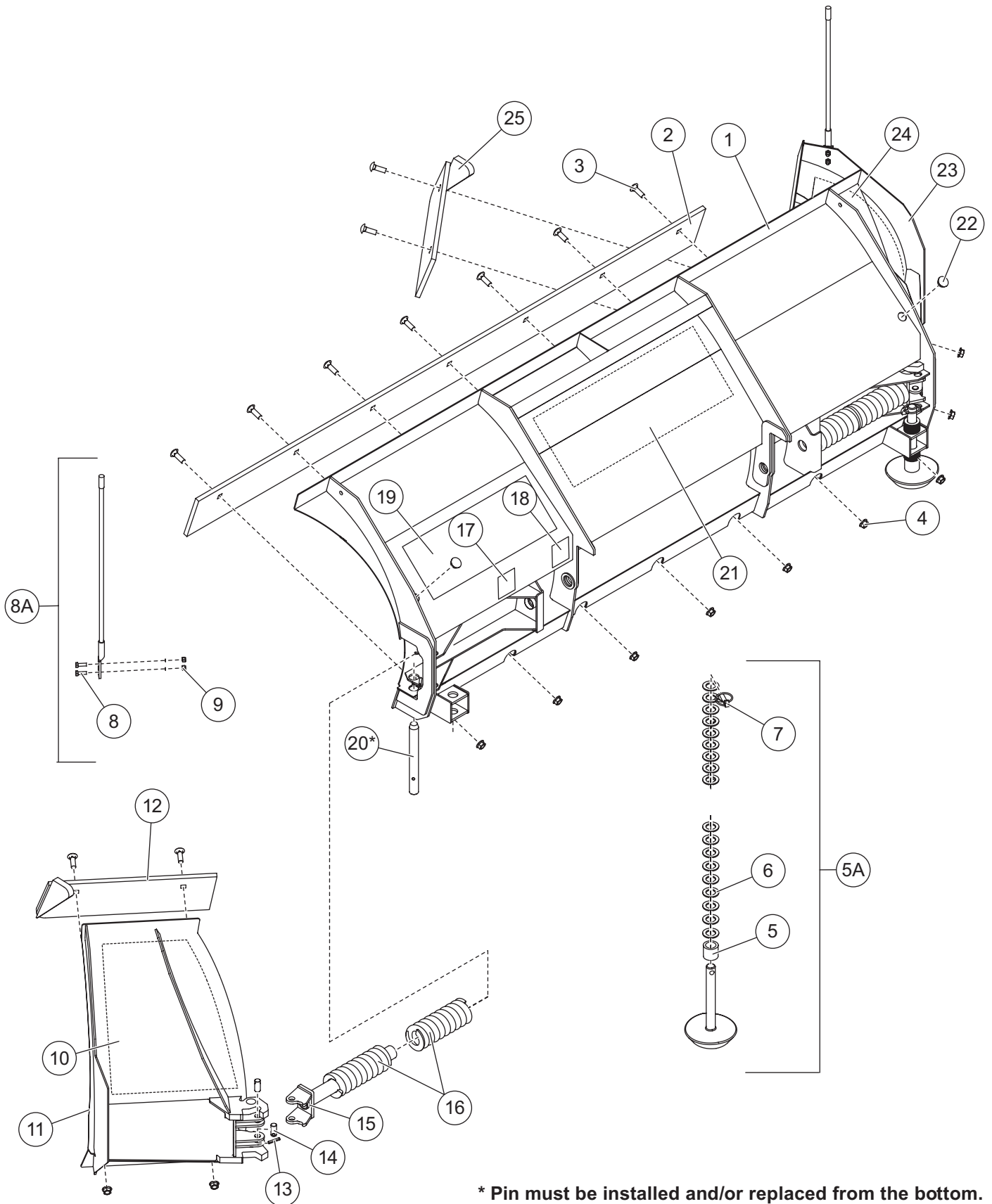

* Pin must be installed and/or replaced from the bottom.

MOLDBOARD & WING PARTS — ALL MODELS

Item	Part	Qty		Description
		760SW	860SW	
1	B53001-1	1	–	Moldboard
	B53048	–	1	Moldboard
2	B61561	1	–	Moldboard Cutting Edge
	B61570	–	1	Moldboard Cutting Edge
3	B61196	10	11	1/2-13 x 1-1/2 Carriage Bolt G8
4	B61365	10	11	1/2-13 Flanged Locknut
5 A	49067	2	–	Disc Shoe Assembly Standard, 7-3/4" Shaft (incl. items 5–7)
	49071	–	2	HD Disk Shoe Assembly
5	60045	2	2	1-1/8 ID, 1-5/8 OD x 1-1/2 Spacer
6	91192	56	52	1" Flat Washer
7	93010	2	2	7/16 x 1-3/4 Linchpin
8 A	B61049	1	1	Plow Guide Assembly (incl. items 8 and 9)
8	68494	4	4	5/16-18 x 1 Hex Cap Screw G5
9	91332	4	4	5/16-18 Hex Locknut Topping GB
10	96323	1	–	Label, Wing – DS
	96327	–	1	Label, Wing – DS
11	B53021	1	–	Wing – DS
	B53062-1	–	1	Wing – DS
12	B61608	1	–	Wing Cutting Edge (T1) – DS
	B61610	–	1	Wing Cutting Edge (T1) – DS
13	B61341	6	6	Pin, Spring \varnothing .25 x 1.5
14	B61577	4	4	Pin, Wing Spring Mount
15	B53076	2	2	Guide, Wing Spring
16	B61569	4	4	Compression Spring
17	29593	2	2	Label – Multiple Pinch Points
18	29256	1	1	Label – Crush Hazard
19	44812	1	1	Label – POWER HITCH™ Mount/Dismount
20	B61564	2	–	Pin, Wing Mounting
	B61572	–	2	Pin, Wing Mounting
21	B63175	1	1	Label, Center Moldboard (BLZ 1085)
22	B61614	2	2	Plug, \varnothing 1.00 Finishing
23	B53033	1	–	Wing – PS
	B53075-1	–	1	Wing – PS
24	96324	1	–	Label, Wing – PS
	96328	–	1	Label, Wing – PS
25	B61609	1	–	Wing Cutting Edge (T1) – PS
	B61611	–	1	Wing Cutting Edge (T1) – PS

G = Grade

A-FRAME & PIVOT BEAM PARTS — ALL MODELS

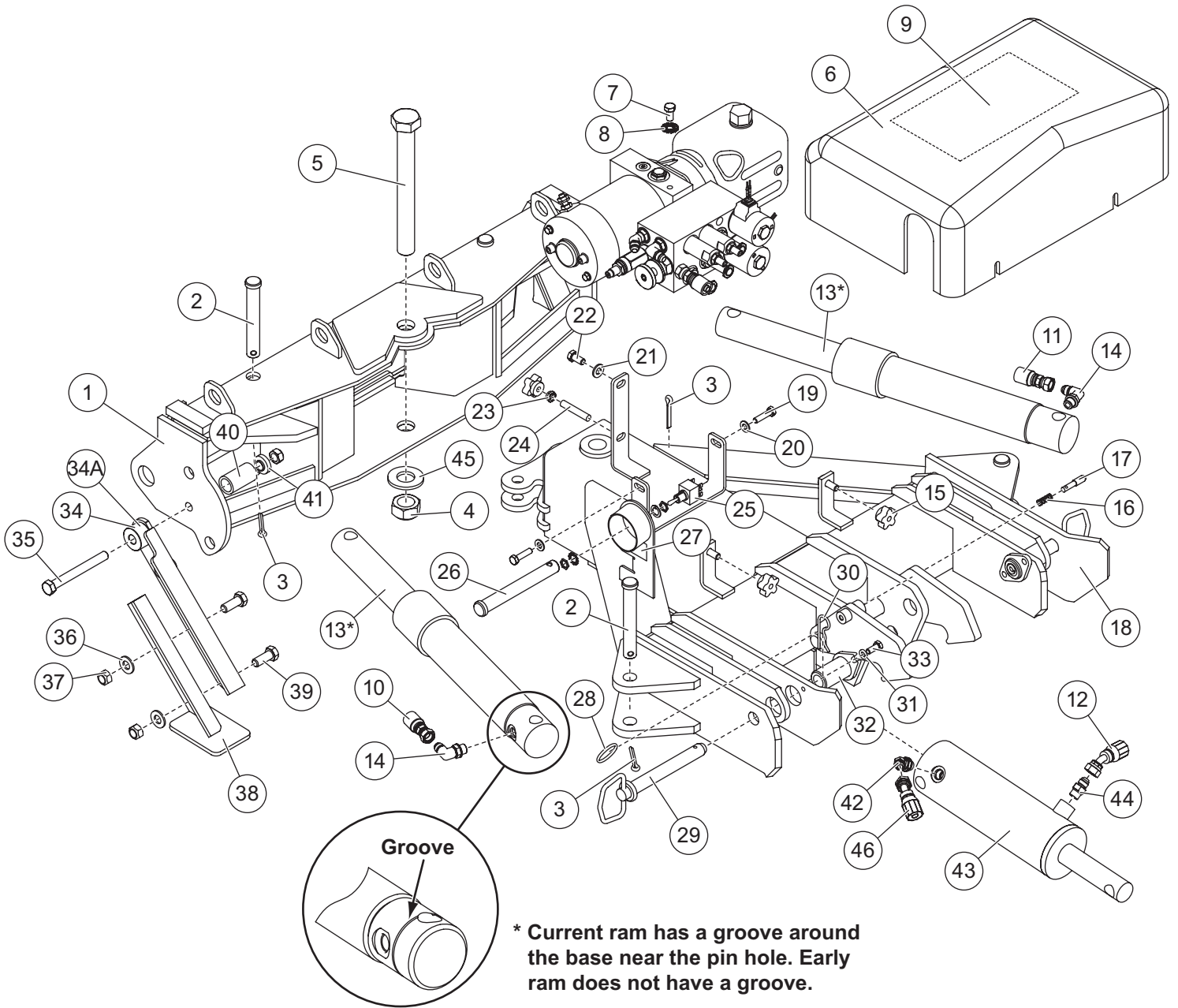

* Current ram has a groove around the base near the pin hole. Early ram does not have a groove.

Item	Part	Qty		Description
		760SW	860SW	
1	B41056	1	—	Pivot Beam
	B41066	—	1	Pivot Beam
2	B40124	4	—	3/4 x 6 Clevis Pin
	95739	—	4	3/4 x 5 Clevis Pin
3	90601	7	7	1/4 x 1-1/2 Cotter Pin
4	B61008	1	1	1-8 Top Locknut GC Distorted Thread
	B61331	1	—	1-8 x 8-1/2 Hex Cap Screw
5	B61330	—	1	1-8 x 9 Hex Cap Screw
	B40119	1	1	Cover, Power Unit/Manifold

G = Grade

A-FRAME & PIVOT BEAM PARTS — ALL MODELS

Item	Part	Qty		Description
		760SW	860SW	
7	90097	1	1	3/8-16 x 3/4 Hex Cap Screw G5
8	B61307	1	1	3/8 Int/Ext Tooth Lock Washer
9	B63185	1	1	Label – Hydraulic Hose Identification Guide
10	B60451	1	1	Hose, 3/8 x 19 w/F JIC Ends
11	B60452	1	1	Hose, 3/8 x 20 w/F JIC Ends
12	B60274	1	1	Hose, 3/8 x 15 w/F JIC Ends
13*	B60065	2	–	Hydraulic Cylinder, Plow Angle (Early ram – see callout on diagram.)
	43813	2	–	Ram Assembly 1-3/4 x 9-3/8 (Current ram – see callout on diagram.)
	B60029	–	2	Hydraulic Cylinder, Plow Angle (Early ram – see callout on diagram.)
	43801	–	2	Ram Assembly 1-3/4 x 10 (Current ram – see callout on diagram.)
14	56590	3	3	Elbow, 90° –6M JIC/–6 M ORB
15	B61628	3	3	3/8-16 Clamping Knob SS
16	B61000	1	1	0.94 O AFL x 0.36 OD, 0.029 Wire Compression Spring SS
17	B40079	1	1	3/8 x 1-3/4 Pin SS
18	B40127	1	–	A-Frame
	B40148	–	1	A-Frame
19	B61680	2	2	5/16-18 x 7/8 Hex Cap Screw G8
20	B61412	2	2	5/16 Hardened Washer
21	29233	1	1	3/8 Hardened Washer
22	90097	1	1	3/8-16 x 3/4 Hex Cap Screw G5
23	91333	1	1	3/8-16 Hex Jam Locknut G8 Topring
24	B61629	1	1	3/8-16 x 2-1/8 Stud
25	B62038	1	1	Toggle Switch DPDT (ON-OFF-ON) 16 A/115V AC
26	B82061	1	–	Clevis Pin
	B40124	–	1	Clevis Pin
27	B61295	1	1	Label – POWER HITCH™ Connect/Disconnect Switch (BLZ 1037)
28	B61309	1	1	1.25 OD Standard Split Ring
29	B61426	3	3	3/4 x 6 Hitch Pin
30	B61105	2	2	9/64 x 2-11/16 Hairpin Cotter
31	B61011	2	2	5/16 Split Lock Washer
32	B40088	2	2	A-Frame Pivot, Replaceable Bushing
33	90671	2	2	5/16-18 x 3/4 Hex Cap Screw G5
34A	B41039	1	1	Kickstand Assembly (incl. items 34–41)
34	B41038	1	1	Kickstand Leg
35	42009	1	1	1/2-13 x 4-1/2 Hex Cap Screw G8
36	90572	2	2	1/2 Flat Hardened Washer
37	90593	3	3	1/2-13 Locknut GC
38	B41047	1	1	Kickstand Foot
39	90665	2	2	1/2-13 x 1-1/4 Hex Cap Screw G8
40	B61293	1	1	1-1/8 OD x 53/64 ID x 2 Compression Spring
41	B41037	1	1	3/8 x 1-1/8 OD x 35/64 ID Stepped Bushing
42	56695	4	4	9/16-18 45° Adjustable Hydraulic Adapter
43	B60236	1	–	Hydraulic Cylinder, 2-1/2 x 4-5/8 DA – Lift
	B60255	–	1	Hydraulic Cylinder, 3 x 4-5/8 DA – Lift
44	B60007	1	1	Connector, Short –6M JIC/–6 M ORB
45	B61203	1	1	1" Washer
46	B60273	1	1	Hose, 3/8 x 17w/F JIC Ends

G = Grade SS = Stainless Steel

DRAW LATCH & FINAL ASSEMBLY PARTS — ALL MODELS

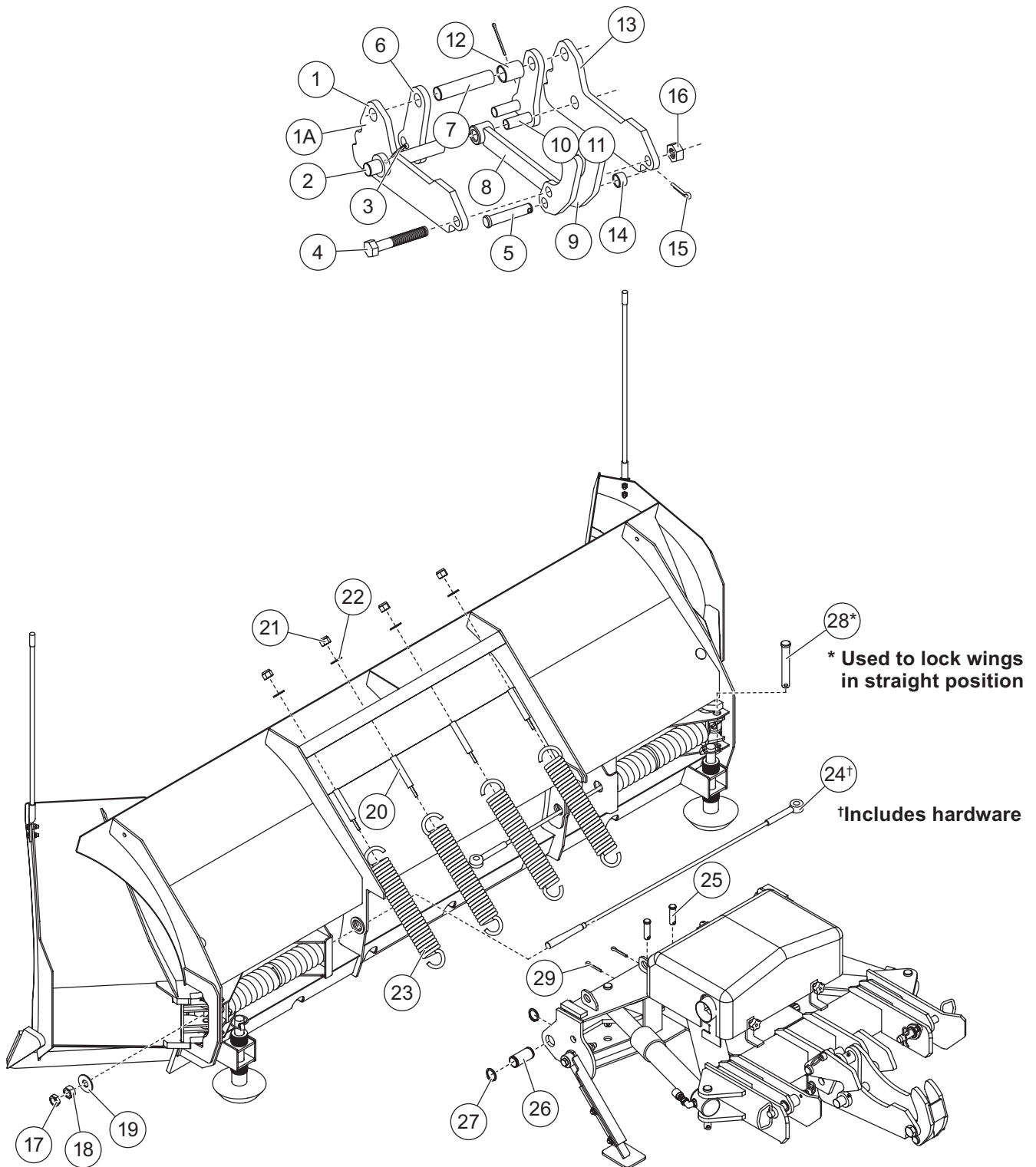

DRAW LATCH & FINAL ASSEMBLY PARTS — ALL MODELS

Item	Part	Qty		Description
		760SW	860SW	
1 A	B82049	1	–	Draw Latch Assembly (incl. items 1–16)
	B40109	–	1	Draw Latch Assembly (incl. items 1–16)
1	B82035	1	–	Outer Draw Latch Plate – DS
	B40080	–	1	Outer Draw Latch Plate – DS
2	B82050	1	–	1 x 5-5/8 Draw Pin
	B40110	–	1	1 x 6-1/2 Draw Pin
3	B61363	2	2	3/16 x 2-1/2 Cotter Pin
4	B61200	1	–	3/4-10 x 4 Hex Cap Screw G8
	B61004	–	1	3/4-10 x 4-1/2 Hex Cap Screw G8
5	B82055	1	–	3/4 x 3-7/16 Clevis Pin
	66950	–	1	3/4 x 4 Clevis Pin
6	B82014	2	–	Inner Draw Latch Plate
	B40074	–	2	Inner Draw Latch Plate
7	40318	1	–	1 x 3-7/8 Draw Pin Latch Mount (to A-frame)
	B40070	–	1	1 x 4-21/32 Draw Latch Pin Mount (to A-frame)
8	B82054	1	–	Draw Latch Arm
	B40114	–	1	Draw Latch Arm
9	B82058	1	–	Draw Latch Finger
	B40123	–	1	Draw Latch Finger
10	B82033	1	–	5/8 x 2-3/8 Inner Draw Pin Latch Plate/Hydraulic Cylinder Rod End
	B40042	–	2	3/4 x 2-1/2 Draw Pin Latch Arm Pivot Pin/Hydraulic Cylinder Rod End
11	B82024	1	–	3/4 x 2-3/8 Draw Pin Latch Arm Pivot
12	B40093	1	1	1-1/4 OD x 1-1/16 ID x 1-1/2 Bushing
13	B82036	1	–	Outer Draw Latch Plate – PS
	B40081	–	1	Outer Draw Latch Plate – PS
14	B40116	1	1	1 OD x 25/32 ID x 5/8 Spacer
15	91911	1	1	5/32 x 1-1/2 Cotter Pin
16	B61006	1	1	3/4-10 Locknut GC
17	B61615	2	2	3/4-10 Hex Jam Nut
18	B61343	2	2	3/4-10 Hex Nut
19	B61576	2	2	3/4 USS Hardened Washer
20	B61201	3	4	5/8-11 x 5.0 Spade Bolt G8
21	91337	3	4	5/8-11 Hex Locknut
22	90576	3	4	5/8 Hardened Flat Washer
23	B61351	3	–	Trip Spring
	23039	–	4	Trip Spring
24†	40987	2	–	Cable Assembly with Hardware 760SW (incl. items 17, 18, 19, 25 and 29)
	40988	–	2	Cable Assembly with Hardware 860SW (incl. items 17, 18, 19, 25 and 29)
25	B61563	2	2	Ø .625 x 2.33 Clevis Pin
26	B16536	2	2	Plow Pivot Bushing
27	B61616	4	4	1-1/8 Heavy-Duty Retaining Ring
28	96222	2		Wing Lock Pin 760SW
	95739		2	3/4 x 5.0 Clevis Pin
29	90601	2	2	1/4 x 1-1/2 Cotter Pin

G = Grade

POWER UNIT PARTS — ALL MODELS

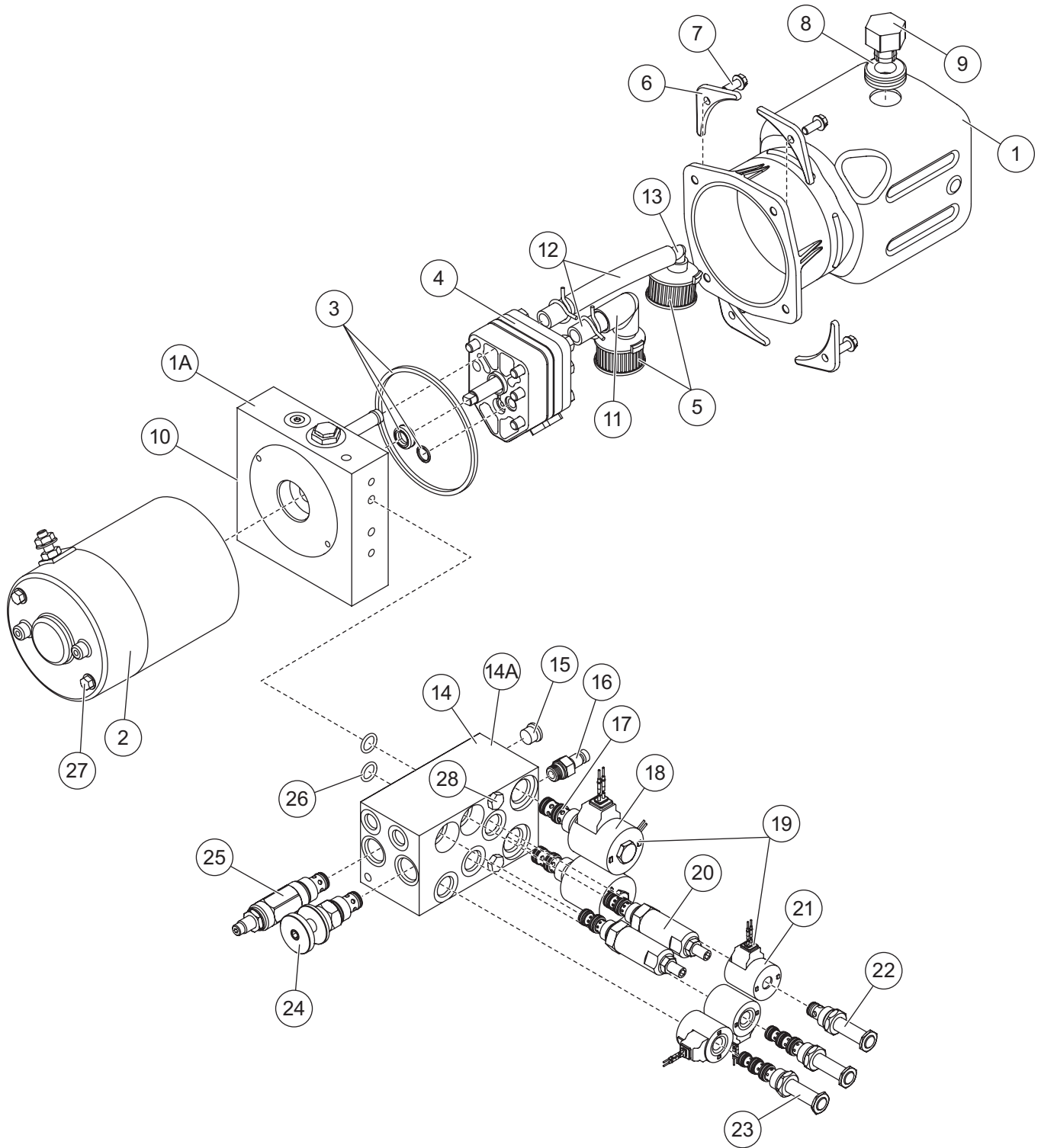

POWER UNIT PARTS — ALL MODELS

Item	Part	Qty	Description
1 A	B60402	1	Hydraulic Pump Assembly (incl. items 1–2 and 4–13) (MTE)
ns	B60491	1	Pump/Manifold Kit (incl. items B60402, B60447, B60448, B62039, B61011 [2], B61412 [2], B61312 [2], B61637 [2], 56805 [4])
1	B60433	1	Reservoir
2	B60434	1	Motor, 12V DC
3	B60435	1	Seal Kit
4	B60436	1	Pump Assembly, 2.47cc/REV
5	B60437	2	Filter
6	B60438	4	Reservoir Clamp
7	B60439	4	Reservoir Screw
8	B60345	1	Grommet
9	B60346	1	Breather
10	B60440	1	Relief Valve Assembly
11	B60442	1	Elbow
12	B60450	2	Tube, cut to length
13	B60444	1	Elbow
14 A	B60447	1	Manifold Assembly
14	B60458	1	Manifold Block
15	B60050	1	Plug, Hollow Hex Male ORB
16	B60173	1	Coupling, Test Port Nipple
17	B60461	2	Cartridge Valve, 3-Way, 2-Position
18	B62237	2	Coil, 10V DC 10-Size
19	B62246	1	Coil Harness Assembly (incl. items 18, 21, B62045, B62096, B62097, B62116 & B62117)
ns	B62045	1	Electric Connector, Male, Plastic
ns	B62096	15	Cable Seal, Silicone 18 ga, Orange
ns	B62097	5	Terminal, Male 18–16 ga
ns	B62116	5	Cavity Plug, Silicone 18–16 ga, White
ns	B62117	1	End Ring Terminal 3/8 ID, Copper, 8 ga
20	B60430	2	Counterbalance Valve 1200 psi
21	B62236	3	Coil, 10V DC 8-Size
22	B60462	1	Cartridge Valve, 2-Way, 2-Position
23	B60460	2	Solenoid Valve, 4-Way, 2-Position CC
24	B60463	1	Flow Control Valve
25	B60459	1	Relief Crossover Valve 3000 psi
26	B60519	2	3/32 O-Ring
27	21508	2	1/4-20 x 6-3/8 Coarse Thread Hex Cap Screw G5
28	B61637	2	5/16-18 x 2-3/4 Hex Cap Screw
			G = Grade
			ga = gauge
			ns = not shown

LIGHTS, HARNESSES & CONTROL PARTS — ALL MODELS

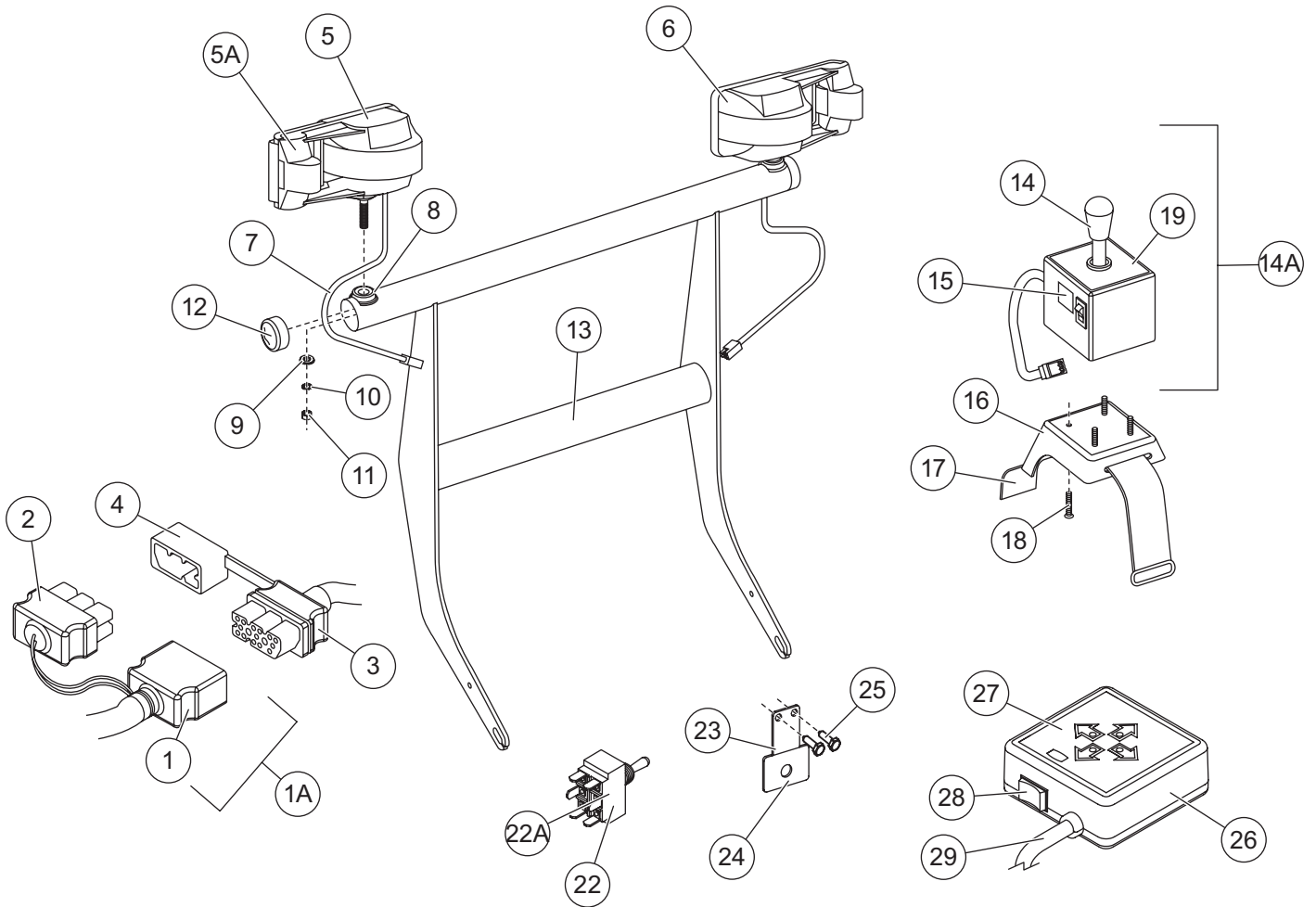

Item	Part	Qty		Description
		760SW	860SW	
1 A	B62039	1	1	Harness Assembly, Snowplow (incl. items 1–2, B62046, B62093, B61439, B62167)
1	B62057	1	1	Harness, Snowplow
2	B62001	1	1	Weather Cap, Rubber – Snowplow Side
ns	B62046	1	1	Electric Connector, Female, Plastic
ns	B62093	10	10	Terminal, Female (18–16 ga)
ns	B61439	2	2	Cable Tie 15", Black
ns	B62167	1	1	Harness, Diode Loop
3	B62150	1	1	Harness, Vehicle
4	B62000	1	1	Weather Cap, Rubber – Vehicle Side
ns	B62124	1	1	1/4 x 1-1/4 BUSS Fuse ARC 15 A/32V
ns	B62212	1	1	Harness, Main Lighting
ns	B62035	2	2	Weather Cap, Lighting Harness, Rubber
ns	B62144	4	4	Headlamp Relay, CB1-D-12V
ns	B80051	1	–	Power Contactor (Solenoid), 12V Continuous
	B62178	–	1	Power Contactor (Solenoid), 12V DC – 225 A
		ns = not shown		ga = gauge

LIGHTS, HARNESSES & CONTROL PARTS — ALL MODELS

Item	Part	Qty		Description
		760SW	860SW	
ns	B62056	1	1	Ground Wire, Power Contactor, 24"
ns	B62072	4	4	End Ring Terminal 3/8 ID, Copper, 4 ga
ns	B62008	1	1	Fuse Clip, Mini
ns	B62009	1	1	Fuse Clip, Auto Blade
ns	B62016	4	4	Connector, Splice Lock (18–14 ga)
ns	B61031	3	3	#12-14 x 3/4 Hex Screw Washer Self-Drilling
5 A	B61106	2	2	Headlamp Assembly (incl. items 5–11 and B62061)
5	B62059	1	1	Headlamp – DS
6	B62060	1	1	Headlamp – PS
7	B62032	2	2	Harness (with 6-pin plug), Snowplow Headlamp Side
ns	B62108	2	2	Lighting Harness Repair Kit, Harness Side
ns	B62061	2	2	Headlamp, Sealed Beam Halogen (H6545/H4666)
ns	56099	1	1	Corrosion Preventive Compound
8	B61231	1	1	Adapter, Headlamp Ball Stud Mount
9	B61550	2	2	1/2 ID x 1 OD Washer Neoprene Backing Galvanized
10	90651	2	2	7/16 External Tooth Lock Washer
11	B61111	2	2	7/16-14 Hex Locknut G8
12	B61427	2	2	2-1/4 ID, 2-3/8 OD x 3/4, Black Vinyl Cap
13	B39034	1	–	Light Tower
	B39032	–	1	Light Tower
14 A	B62073	1	1	Control Station Assembly, Joystick (incl. items 14–19, B62185–B62190)
14	B62074	1	1	Control Station, Joystick
15	B63106	1	1	Label – Snowplow Power Switch, ON/OFF (BLZ 1061)
16	B61185	1	1	Base Plate, Joystick Control Station 1/8 ABS Plastic
17	B61127	1	1	61" Hook-and-Loop Fastener Strap with 2" D-Ring, Black
18	B61254	4	4	#8-32 x 3/4 Pan-Head Machine Screw
19	B61174	1	1	Label – Joystick Control Station (BLZ 1017)
ns	B62185	1	1	Switch, Rocker SPDT (ON-OFF-ON) Straight Blade Joystick Control Switch
ns	B62186	1	1	Switch, Straight Blade Joystick Functions
ns	B62187	1	1	Relay, Straight Blade Joystick
ns	B62188	1	1	Switch Actuator
ns	B62189	1	1	Handle Kit, Straight Blade Joystick (incl. Shaft, Sleeve, E-Ring).
ns	B62190	1	1	Mounting Plate
22 A	B62138	1	1	Snowplow/Vehicle Headlamp Toggle Switch Connection Kit (incl. items 22–25)
22	B62024	1	1	Toggle Switch DPDT (ON-OFF-ON) 20 A/125V AC
23	B61041	1	1	Bracket, Snowplow/Vehicle Headlamp Toggle Switch
24	B61088	1	1	Label – Snowplow/Vehicle Headlamp Toggle Switch Bracket (BLZ 1008)
25	B61031	5	5	#12-14 x 3/4 Hex Screw Washer Self-Drilling
ns	B62127	1	1	Plow Light ON/OFF Switch Lead 24" (Green/Yellow) with two 1/4 Receptacles
26	B62142	1	1	Touchpad Control Station (incl. items 37–39)
27	B62192	1	1	Label – Touchpad Control, with Adhesive Pads
28	B62191	1	1	PC Board, Touchpad Control
29	B62202	1	1	Harness, Touchpad Control
G = Grade		ga = gauge		ns = not shown

ACCESSORIES & KITS — ALL MODELS



1. The snowplow airfoil helps channel air flow to your truck radiator during the long haul over the road. Mounted front and center, our custom airfoil redirects air over the top of the blade and into the grille of your vehicle. The airfoil is shipped with complete mounting hardware.



3. Our easy-to-install, adjustable pedestal mount will position either straight blade control station how you want it! Ideal for bucket seat vehicles with low center consoles. Pedestal accessory shipped with complete hardware and adapter plate.



2. BLIZZARD® hydraulic fluid is specially formulated for use in BLIZZARD snowplows and can significantly enhance the operation and performance of the hydraulic system. BLIZZARD zinc-free hydraulic fluid maintains its viscosity to temperatures as low as -25°F . BLIZZARD hydraulic fluid is available by the quart, gallon or 55-gallon drum.

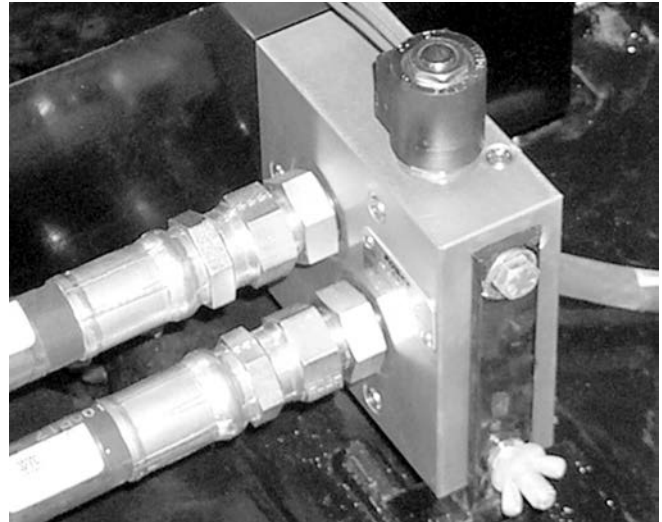

4. Experience increased power and speed in all of the snowplow hydraulic functions with this easy-to-install add-on central hydraulic valve block! The auxiliary manifold bolts right up to the existing manifold and pump bracket without any modifications needed. Manifold provides up to 30 gpm input (4000 psi max.) from the vehicle pump and 2–3 gpm output (2500 psi max.) to the existing hydraulic manifold. Hydraulic hoses, fittings and pump not included.

ACCESSORIES & KITS — ALL MODELS



5. This adjustable bracket mounts easily to your straight blade joystick control and installs quickly onto any door panel. Ideal for left-hand joystick operation or for vehicles with center consoles. The window mount bracket is shipped complete with hardware. Some assembly required.

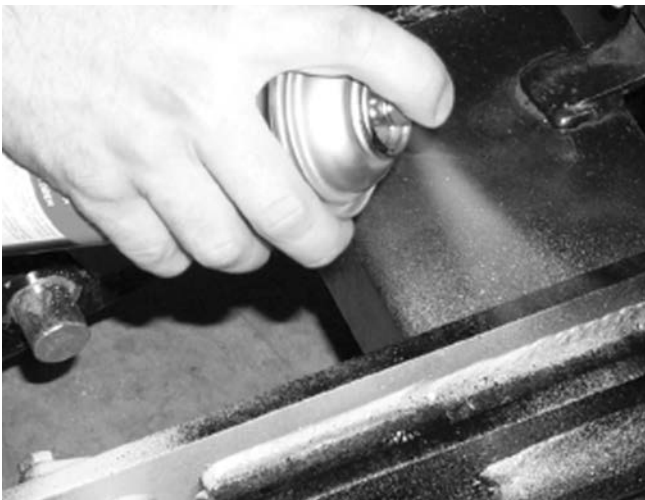

6. Putting your snowplow away for the winter? Have a deep scratch to cover? Clean up your blade and snowplow parts with our gloss spray paints. BLIZZARD® touch-up paint provides an excellent finish to help keep your snowplow looking its best. Paint provided in 12-oz spray cans.

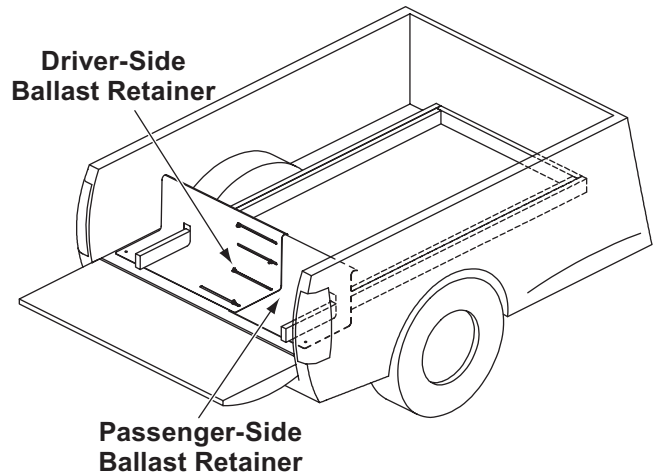

7. Ballast (additional weight) is an important part of qualifying vehicles for snowplow eligibility. Rear ballast must be used when necessary to remain in compliance with axle ratings and ratios as specified by the vehicle manufacturer. If ballast is required, it is important that it be secured properly behind the rear axle. A ballast retainer kit is available from your BLIZZARD outlet, PN 62849.

NOTE: The ballast retainer kit is for snowplow vehicles requiring ballast. See your BLIZZARD outlet for the correct amount of ballast required. Include the weight of the retainer as part of the ballast requirement. Sand bags are recommended for use as ballast.

NOTE: Ballast recommended and its weight calculations assume the entire width of the bed is filled as close to tailgate as possible.

ACCESSORIES & KITS — ALL MODELS

Item	Part	Qty		Description
		760SW	860SW	
1	B81041	1	–	Snowplow Airfoil
	B52093	–	1	Snowplow Airfoil
2	B63070	1	1	BLIZZARD® Rapid Action Hydraulic Fluid (quart)
	B63072	1	1	BLIZZARD Rapid Action Hydraulic Fluid (gallon)
	B63091	1	1	BLIZZARD Rapid Action Hydraulic Fluid (drum – 55 gallons)
3	B63078	1	1	12" Adjustable Pedestal Mount
4	B60310	1	1	Central Hydraulic Valve Block
5	B61261	1	1	Window Mount Bracket, Straight Blade Joystick
6	B61219	1	1	BLIZZARD High Performance Spray Paint (12 oz), Gloss White
	B63073	1	1	BLIZZARD High Performance Spray Paint (12 oz), Gloss Black
7	62849	1	1	Ballast Retainer Kit
ns	B21034	1	1	Tool, SPEEDWING™ Spring
Kits				
ns	B61630	1	–	Hardware Kit, Snowplow Assembly Parts
ns	B61651	–	1	Snowplow Airfoil
ns	B60448	1	1	Hydraulic Adapter Kit (incl. items 56590 [3], B60007, 56695 [4])
ns	B60449	1	1	Hydraulic Hose Kit (incl. items B60273, B60274, B60451, B60452)
ns	B61255	1	1	Bolt Bag, Cutting Edge Kits
ns	B61647	1	–	Moldboard Cutting Edge Kit with Hardware
ns	B61648	–	1	Moldboard Cutting Edge Kit with Hardware
ns	B61646	1	1	Hardware Kit, Wing Cutting Edge
ns	B61649	1	–	Wing Cutting Edges Kit with Hardware
ns	B61650	–	1	Wing Cutting Edges Kit with Hardware
ns	B60360	1	1	Combo Seal Kit, Cylinder B60029/B60065
ns	43792	1	1	Seal Kit Ram Assembly 43801, 43813
ns	B60368	1	–	Combo Seal Kit, Cylinder B60236
ns	B60371	–	1	Combo Seal Kit, Cylinder B60255
ns	B62195	1	1	Headlamp Replacement Kit B61106 (Sealed Beam, Rim, Spacer Bumpers [4], Screws [4])
ns	B62196	1	1	Turn Signal Replacement Kit (Lamp, Turn Signal Lens, Gasket, Screws [2])
ns	96024	1	–	Moldboard Label Pack
ns	96035	–	1	Moldboard Label Pack
ns = not shown				



Blizzard
PO Box 245038
Milwaukee, WI 53224-9538
www.blizzardplows.com

 A DIVISION OF DOUGLAS DYNAMICS, LLC



Copyright © 2014 Douglas Dynamics, LLC. All rights reserved. This material may not be reproduced or copied, in whole or in part, in any printed, mechanical, electronic, film or other distribution and storage media, without the written consent of Blizzard. Authorization to photocopy items for internal or personal use by Blizzard outlets or snowplow owner is granted.

Blizzard reserves the right under its product improvement policy to change construction or design details and furnish equipment when so altered without reference to illustrations or specifications used. Blizzard or the vehicle manufacturer may require or recommend optional equipment for snow removal. Do not exceed vehicle ratings with a snowplow. This product is manufactured under the following U.S. patents: 5,638,618; 5,899,007; 6,178,669; 6,253,470; 6,276,076; 6,393,737; 6,408,549; 6,412,199; 6,442,877; 6,615,513; 7,134,227; 7,430,821; CAN patents 2,184,922; 2,229,783; 2,259,508; 2,358,145; 2,358,354; 2,466,195; and other patents pending. Blizzard offers a limited warranty for all snowplows and accessories. See separately printed page for this important information. The following are registered (®) or unregistered (™) trademarks of Douglas Dynamics, LLC: BLIZZARD®, BUCKET BLADE™, POWER HITCH™, SPEEDWING™.

Printed in U.S.A.