

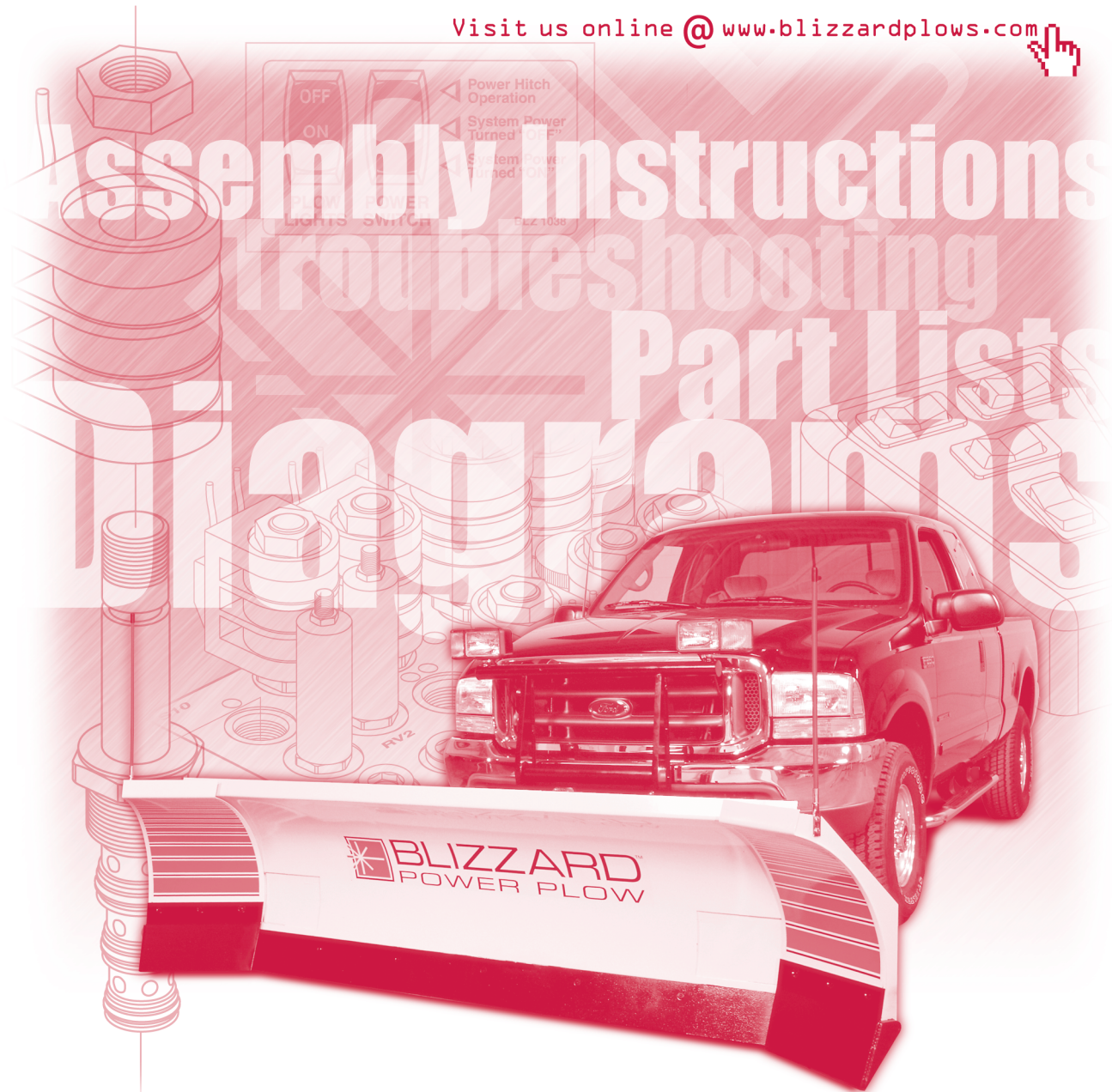

**2001/02**

Visit us online @ [www.blizzardplows.com](http://www.blizzardplows.com) 



## ASSEMBLY & OPERATION MANUAL

Blizzard Power Plow Snowplow  
Model 810

## Introduction

Congratulations on purchasing the most advanced snowplow available! The Blizzard Power Plow is clearing new trails for innovative design, rugged durability, quality craftsmanship and superior performance. Our exclusive products are manufactured and tested in Michigan's Upper Peninsula, the snow capital of the Midwest. With an annual snowfall averaging over 250", we couldn't imagine building snow removal products anywhere else!

Your Blizzard Power Plow is equipped with versatile features designed for years of dependable service. The hydraulic draw latch mounting system positively aligns the plow for fast installation or removal. Twelve-inch expanding wings automatically transform a compact 8' blade into a massive 10' machine. Also, the independent wings can pivot forward to form our 9'-3" BucketBlade™ position. Now you can carry more snow even further. Safety features include full moldboard trip action, enclosed hydraulics and automatic cylinder pressure relief.

To ensure years of optimum snowplow performance, review the contents of this manual. It contains assembly information, detailed diagrams, complete parts listings, maintenance guidelines and troubleshooting tips.

Should you need additional information, contact your local Blizzard Power Plow Dealer. Their knowledgeable staff is well informed on the latest Power Plow information. They are also your source for replacement parts, technical assistance and all service repairs.

Comments, suggestions or concerns?  
Address all correspondence to:

Blizzard Corporation  
Customer Service Department  
95 Airpark Boulevard  
Calumet, MI 49913  
(888) 680-8600  
(906) 482-5555  
(906) 482-5445 Fax

# TABLE OF CONTENTS

<b>01</b>	Snowplow Operation
<b>02</b>	Warning!
<b>Assembly Instructions</b>	
<b>03</b>	Unpacking & Inspection
<b>04</b>	Moldboard & A-frame Assembly
<b>08</b>	Electrical Assembly - Plow Harness
<b>09</b>	Electrical Assembly - Vehicle Harness
<b>12</b>	Testing The Snowplow
<b>13</b>	Mounting & Dismounting Instructions
<b>Maintenance &amp; Plow Specifications</b>	
<b>14</b>	Regular Maintenance
<b>15</b>	Storing Your Snowplow
<b>16</b>	Plow Specifications
<b>Plow Diagrams &amp; Part Lists</b>	
<b>17</b>	Model 810 Parts List
<b>21</b>	Hydraulic Manifold Detail
<b>22</b>	Model 810 Assembly Schematic
<b>24</b>	Coil Harness Wire Schematic / Hydraulic Manifold Schematic
<b>Electrical Diagrams</b>	
<b>25</b>	Molded Plug Pin Locations (2001-2002)
<b>26</b>	Plow Harness (2000-2002)
<b>27</b>	Plow Harness Wire Schematic (2000-2002)
<b>28</b>	Main Lighting Harness - Relay Version (2001-2002)
<b>29</b>	Main Lighting Harness Wire Schematic (2001-2002)
<b>30</b>	Vehicle Harness - Relay Version (2001-2002)
<b>31</b>	Vehicle Harness Wire Schematic (2001-2002)
<b>32</b>	On/Off Switch Leads & Ground Lead (2001-2002)
<b>Undercarriage Assembly Instructions</b>	
<b>33</b>	Technical Service Bulletin - Ford Blocker Beam™
<b>34</b>	1987-1991 Ford F-250 & F-350 Series
<b>36</b>	1992-1998 Ford F-250 & F-350 Series
<b>38</b>	1999-2002 Ford F-250 & F-350 Series
<b>40</b>	1999-2002 Ford F-450 & F-550 Series
<b>42</b>	1982-1987 Chevrolet/GMC C20/C30 & K20/K30
<b>44</b>	1988-1998 Chevrolet/GMC 2500 & 3500 Series, 1999-2000 Chevrolet/GMC 3500 Series
<b>46</b>	1988-2000 Chevrolet/GMC 1 Ton Heavy-Duty 2WD
<b>48</b>	1999-2002 Chevrolet/GMC 2500 Series
<b>50</b>	1979-93 Dodge 2500 & 3500 Series
<b>52</b>	1994-2001 Dodge 2500 & 3500 Series
<b>Troubleshooting</b>	
<b>54</b>	Troubleshooting Guide
<b>Warranties</b>	
<b>56</b>	Limited Consumer Warranty
<b>57</b>	Commercial Warranty

# SNOWPLOW OPERATION

Your Power Plow is the most advanced and versatile snowplow on the market. The easy to use controls allow you to automatically adjust the plow blade and wings into an infinite number of plowing positions. Review the illustrations below to determine the best position for your plowing needs.

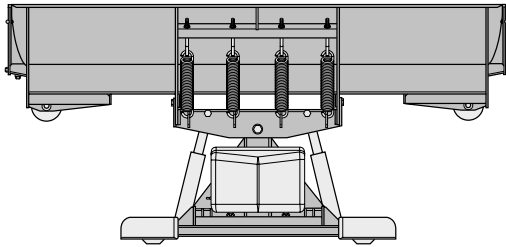

## Compact Position (8' Blade Width)

- Primary position when transporting the snowplow
- For use in heavy snow conditions with poor visibility, initial clearing and tight quarters
- *Ideal application: Residential driveways, small roads*

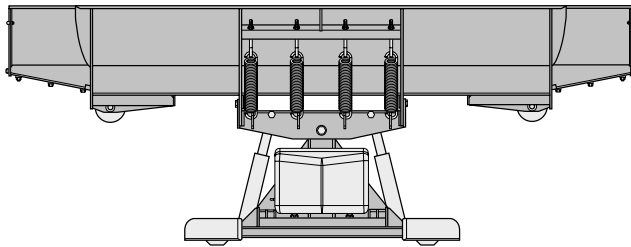

## WidePass™ Position (10' Blade Width)

- Primary position for clearing large surfaces
- For use in light snow conditions with good visibility, final clearing and clean-up
- *Ideal application: Large parking lots, widening roadways*

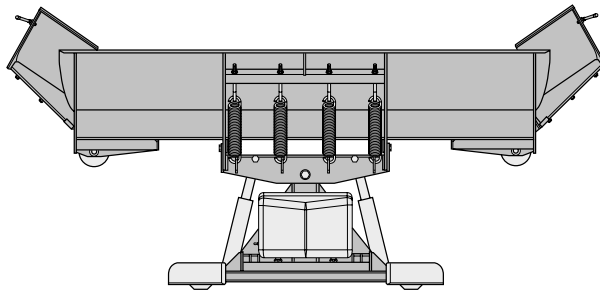

## BucketBlade™ Position (9'-3" Blade Width)

- Primary position for transporting snow
- For use in initial clearing with decent visibility, transporting large volumes of snow, final clean-up
- *Ideal application: Roadway intersections*

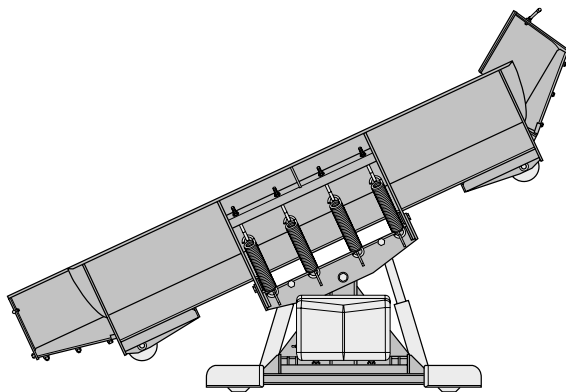

## WidePass™ Position Angled with Wing Forward

- Primary position for accelerated angled plowing
- For use in directional plowing, cornering, diverting snow away from objects or buildings
- *Ideal application: Plowing adjacent to buildings, driveway/road intersections*

# WARNING!



## WARNING:

Prior to operating your Power Plow, review the WARNING! label at the passenger's side rear of the moldboard (shown below).



## CAUTION:

*Note: Read and understand all warnings indicated in this manual prior to operating the snowplow. Warnings and cautions in the manual are indicated by the icons shown to the left.*

# WARNING

1. Make sure the main power switch on the control unit is in the "OFF" position when attaching the snowplow.
2. Properly attach the snowplow prior to moving the vehicle.
3. Stand clear of the attachment area when mounting the snowplow to the undercarriage and operating the Power Hitch Connect/Disconnect switch. Failure to do so may result in serious injury or death.
4. Securely position all mounting pins prior to operating your snowplow.
5. Do not position your body between the snowplow and the vehicle when servicing or operating.
6. Position snowplow in such a manner as to not block your vision or plow headlights while in transit.
7. Always travel with the wings fully retracted. Depending on local and state regulations, you may be exceeding the legal vehicle width when the wings are fully or partially extended.
8. Do not change the position of the blade while in transit.
9. Do not exceed 40 mph when transporting plow.
10. Do not exceed 10 mph when plowing.
11. Always lower blade when vehicle is parked.
12. Vehicles equipped with air bags are designed to be activated in a frontal collision equivalent to hitting a solid object or barrier at approximately 14 mph or more.

## WARNING

Careless or high speed driving while plowing snow, which results in vehicle impact deceleration equivalent to or greater than the airbag deployment threshold described above, would deploy the airbag.

Blizzard Power Plow is protected by U.S. Patent 5,899,007, U.S. Patent 5,638,618. Other patents pending.

Do not exceed Gross Vehicle Weight Rating (GVWR) or Gross Axle Weight Rating (GAWR) including the blade and ballast. Refer to your Owner's Manual for proper GVWR and GAWR ratings for your vehicle.

**READ  
OWNER'S  
MANUAL  
THOROUGHLY  
PRIOR TO  
OPERATING  
PLOW.**

 **BLIZZARD®  
CORPORATION**

Calumet, MI 49913

BLZ 1005

Should the WARNING! label or any of the labels that came with your snowplow become hard to read or wear off, contact your local dealer or call our Customer Service Department at 1-888-680-8600 for replacements.

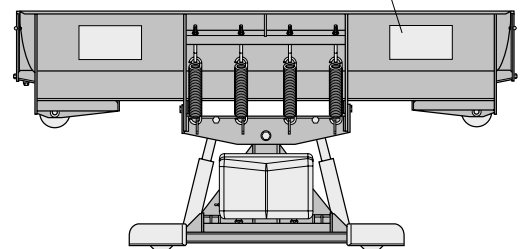

# ASSEMBLY INSTRUCTIONS

## Unpacking & Inspection

Your Blizzard Power Plow has been packaged to withstand transit and weather related damage. Fully inspect all components upon receipt of your plow. In the event of shipping damage or missing parts, immediately contact our Customer Service Department toll free at 1-888-680-8600.

Begin unpacking and inspection in the following order:

1. Remove packaging slip from the end panel of the pallet wrap. Retain all documentation for your records.
2. All wood framing and polyethylene material should be removed from the pallet for easy access to the snowplow.
3. Due to the odd shaped components and size of several assembly parts, various nylon ties and corrugates are used for scratch resistance and package orientation. Please remove these items prior to assembly.
4. Place the main blade assembly on a flat, level surface.

Once you have inspected all parts and removed all restraining and protective packaging materials, your snowplow is ready to be fully assembled.

\_\_\_\_\_  
Date of Purchase

\_\_\_\_\_  
Dealer/Distributor

\_\_\_\_\_  
Telephone Number

\_\_\_\_\_  
Snowplow Serial Number

\_\_\_\_\_  
Hydraulic Pump Serial Number

**THIS SIDE UP** ▲

**SHIPPING INFORMATION AND PACKAGING CONTENTS**

PACKAGING LIST 

**MAKE:**  FORD  GMC/CHEVY  DODGE  OTHER \_\_\_\_\_

**MODEL:**  GAS  DIESEL \_\_\_\_\_ **YEAR:** \_\_\_\_\_

**PLOW MODEL:** \_\_\_\_\_ 

U.S. PATENT NO. 5,638,618 U.S. PATENT NO. 5,999,007 OTHER PATENTS PENDING

**BLIZZARD**™  
POWER PLOW

**MADE IN THE U.S.A.**

**POWER HITCH**™



▼ **FORKLIFT POINTS** ▼

### Pallet Wrap End Panel

The tear resistant woven polyethylene pallet wrap contains a moisture barrier to help protect all packaged components and keep out the most inclement weather during shipping and storage. The end panel of the pallet cover contains important information regarding the make, model, and year of the vehicle the enclosed undercarriage is to be installed on. The plow model number and the serial number of the snowplow are given together. The first three digits of the number indicated is always the plow model – 810 and the entire seven digit number make up the serial number. The packaging list is also attached to the end panel. Be sure to retain this list for your records.

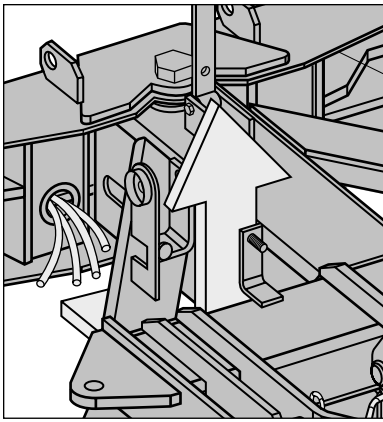

Feed each group of hoses (four per side) through the 1-1/2" diameter holes in the pivot beam and up through the A-frame openings. Positioning the hoses through the pivot beam supports the hoses while the snowplow is in use and prevents them from dragging on the ground.

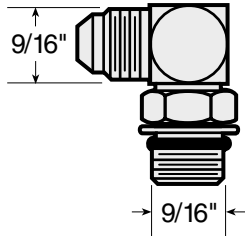

9/16"-18 x 9/16"-18 90° Adjustable Elbow O.R.B. Adapter

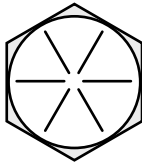

Maximum Bolt Torque  
(Dry Conditions Only)

Diameter-Thread Pitch	Grade 8 (foot-pounds)
1/4"-20	11 ft-lbs
5/16"-18	24 ft-lbs
3/8"-16	44 ft-lbs
7/16"-14	70 ft-lbs
M12 x 1.75	88 ft-lbs
1/2"-13	107 ft-lbs
M14 x 2.0	140 ft-lbs
9/16"-12	154 ft-lbs
5/8"-11	211 ft-lbs
3/4"-10	376 ft-lbs
1"-08	900 ft-lbs

Note: Use 25% less torque when lubricated. Check and re-tighten all fasteners after the first three hours of use. Periodically review all fasteners after the initial inspection.

## Moldboard & A-frame Assembly

1. Begin the moldboard assembly by positioning the PIVOT BEAM and A-FRAME near the connecting points at the rear of the blade between the two center support ribs. Feed the right and left group of HYDRAULIC HOSES protruding from the SLIDE BOX through the 1-1/2" diameter rubber grommet openings in the front face of the pivot beam.



**CAUTION:** The hoses inside of the slide box are installed such that they move laterally with the action of each wing. To avoid damaging the hose connections and the wing and slide box cylinders, pull approximately one foot of each hose grouping toward the center of the moldboard. Verify that there is approximately 12" of "slack" for each hose grouping. Reposition both 12" lengths back into the slide box – the hoses are now at a safe travel distance for operation.

The slide box is closed by two SLIDE BOX ACCESS PLATES. Rest each grouping of hoses in the opening of the plates and position the "lip" of each plate in the bottom, inside edge of both slide box openings. Fasten each plate with two 1/4"-20 x 3/4" hex cap screws.

2. Position the pivot beam between the two support ribs until the connecting points on the beam align with those on the plow. Insert one 3/4"-10 x 3-1/2" hex head screw through each mounting hole and secure with a 3/4"-10 top lock nut. Tighten each nut until it is snug with the pivot beam.



**CAUTION:** Do not over tighten hex head nuts! Binding may prohibit the pivot beam from moving properly on the plow.

Note: To aid in the remaining installation, rotate the spring loaded kickstand clockwise until it locks into place. Adjust the foot on the kickstand arm so the height of the A-frame, at its mount points, is 12-1/2" to level ground (See diagram on page 8). Tighten both of the 1/2"-13 top lock nuts on the kickstand.

3. Position each ANGLE CYLINDER with the rod end of the cylinder in the pivot beam and the hydraulic hose port facing away from the A-frame. Secure the cylinder to the pivot beam with one 3/4"-10 x 5" hex cap screw and one 3/4"-10 top lock nut. Extend each cylinder rod until the cylinder base mounting hole aligns with the hole on the A-frame angle cylinder bracket. At this point, insert one 3/4"-10 x 5" hex cap screw through the aligned holes and secure the screw with one 3/4" top lock nut. Repeat the same installation for the opposite angle cylinder.

4. Remove each dust cap from both of the hydraulic angle cylinder ports and attach one 9/16"-18 x 9/16"-18 90° ADJUSTABLE ELBOW O.R.B. ADAPTER to each port. Note: All of the hydraulic adapters can be found packaged with the manifold assembly. Hand tighten each adapter until snug, then torque approximately 1-1/2 to 2-1/2 flats. Reference the table on page 5 for proper torque specifications. Angle each adapter toward the top of the moldboard and tighten approximately 1-1/2 flats. Connect the 3/8" x 24" hydraulic hose, labeled #1, to the driver's side angle cylinder adapter. Attach the 3/8" x 24" hydraulic hose, identified by a #2, to the passenger's side angle cylinder adapter. Be careful not to overtighten the hose connections. Route both hoses over the top of each angle cylinder.

- Next, remove both of the plastic dust caps from the HYDRAULIC LIFT CYLINDER ports. Attach one 7/16"-20 x 7/16"-20 45° ADJUSTABLE ELBOW O.R.B. ADAPTER to the driver's side port and one 7/16"-20 x 7/16"-20 MALE O.R.B. CONNECTOR ADAPTER to the passenger's side port. Once the adapters have been installed on the cylinder, connect the HYDRAULIC HOSES. The 45° adapter on the driver's side of the cylinder receives a 1/4" x 17" hose identified by a label containing the number 3. Connect the 45° angle on the hose to the hydraulic adapter on the cylinder. The male connector adapter on the passenger's side of the cylinder receives a 1/4" x 15" hose identified by a label containing the number 4. Tighten the 45° end of the hose to the hydraulic adapter on the cylinder.
- Next, use a screwdriver to pull the hydraulic cylinder rod out from its base. Place one 1-1/4" diameter washer over the cylinder rod, followed by the 12" COMPRESSION SPRING and another 1-1/4" washer. Compress the coils approximately 2" and clamp the spring and washers in place using a pair of vise grips. This will help facilitate the draw latch installation.

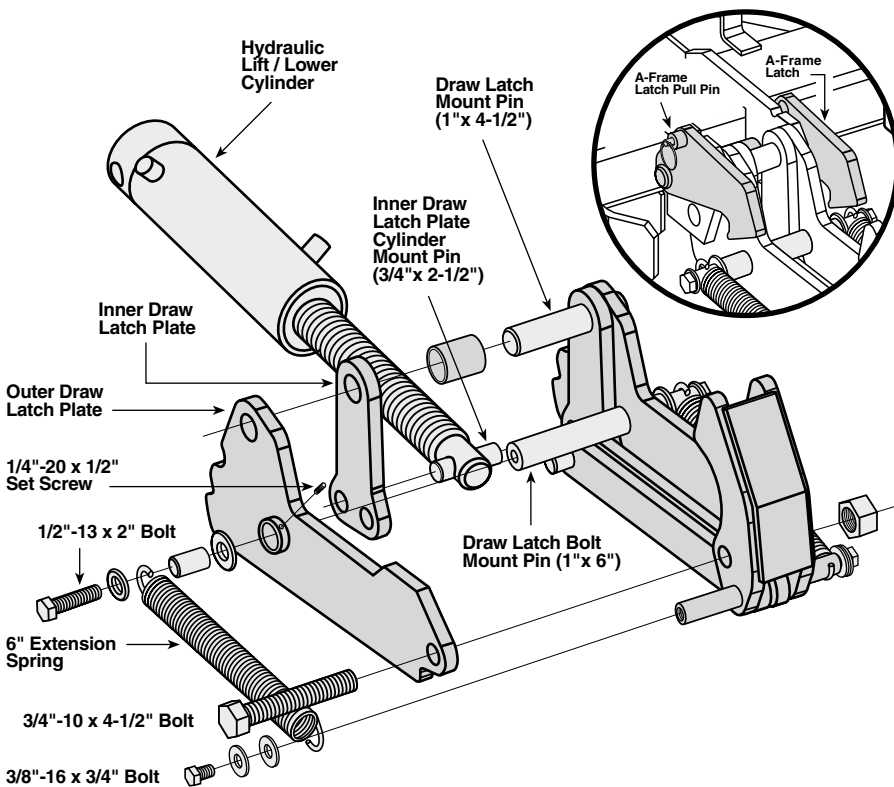

- Begin the draw latch installation by first removing both of the 6" extension springs on the latch. Proceed to remove both 1/2"-13 x 2" bolts with washers and spacers from the DRAW LATCH BOLT MOUNT PIN. Once the springs and hardware have been removed, loosen the SET SCREW on the OUTER DRAW LATCH PLATE using a 1/8" Allen wrench and remove the draw latch bolt mount pin from the assembly.

Next, remove the 1" x 4-1/2" DRAW LATCH MOUNT PIN from the assembly. By removing this pin, the INNER DRAW LATCH PLATES can swing free. Proceed to remove the 3/4" x 2-1/2" INNER DRAW LATCH PLATE CYLINDER MOUNT PIN. Position the plates on either side of the

### Draw Latch Assembly

The draw latch consists of a series of interconnected plates and pins that attach to the A-frame and the hydraulic cylinder that raises and lowers the plow. The draw latch is also the most difficult component to install on the entire plow and may require the help of a second technician.

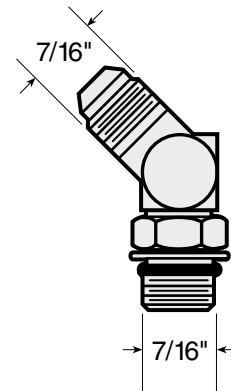

7/16"-20 x 7/16"-20 45° Adjustable Elbow O.R.B. Adapter



7/16"-20 x 7/16"-20 Male O.R.B. Connector Adapter

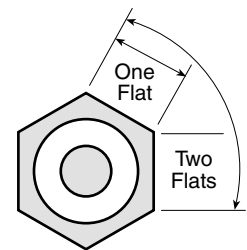

Torque Table for 37° Adapters

Port Thread Size	Assembly Torque (foot-pounds)	Original Assembly (F.F.F.T.)
7/16-20	15 ± 1.0	2.5 ± .25
9/16-18	18 ± 2.0	2.5 ± .25

Torque Table for O.R.B. Adapters

Port Thread Size	Assembly Torque (foot-pounds)	Original Assembly (F.F.F.T.)
7/16-20	15 ± 1.0	1.5 ± .25
9/16-18	25 ± 2.0	1.5 ± .25

F.F.F.T. = Flats From Finger Tight

Ex.) After threading a 7/16-20 O.R.B. adapter finger tight, torque the fitting approximately 1-1/2 flats (faces) for proper installation.

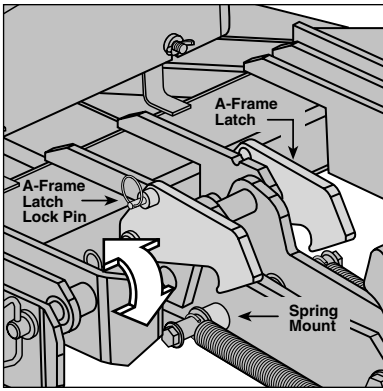

To mount the straight blade, the A-frame latch should be lowered over the spring mount—this allows the draw latch to pull the plow into the undercarriage. Once the plow is safely attached to the undercarriage, rotate the A-frame latch counterclockwise until the lock pin snaps in place. The A-frame latch is only used to mount the plow.

### Installing The Manifold Adapters

There are a total of 24 hydraulic adapters to install. All of the adapters can be found packaged with the manifold assembly. Remove the protective stretch wrap from the manifold in a clean area. **DO NOT** let any foreign objects enter into the open ports. The valves can become contaminated and greatly hinder the plow's performance. Review the table on page 5 for proper torque specifications.

The gray arrows shown on the manifold illustration to the right indicate the direction the 90° adapters should face to receive the hydraulic hoses.

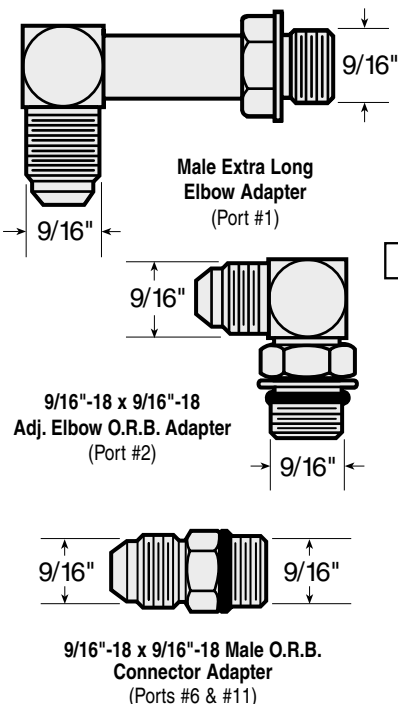

lift/lower cylinder rod and insert the 3/4" x 2-1/2" pin through the plates and cylinder rod. *Note: The A-FRAME LATCH, located at the rear center of the A-frame, should be in the down position. Pull the A-FRAME LATCH PULL PIN out and rotate the latch clockwise if it is in the raised position.* Now that the cylinder is connected to the inner draw latch plates, rotate the draw latch assembly toward the draw latch mount holes on the A-frame. Align the holes in the outer draw latch plate with those of the inner draw latch plates and the A-frame. Secure the assembly to the A-frame by replacing the draw latch mount pin. Remove the vise grips from the cylinder rod. This will allow the compression spring to expand against the draw latch.

Rotate the A-frame latch counterclockwise until the A-frame latch pull pin locks into place. Next, replace the draw latch bolt mount pin. The pin should be evenly spaced on either side of the outer draw latch plates. Tighten the set screw to secure the pin in place. Complete the draw latch assembly by replacing the washers, spacers, extension springs and bolts on both sides of the draw latch bolt mount pin.

Once you have completed the draw latch installation, we will shift our attention to assembly of the manifold. The manifold, pump and coil harness have been preassembled at the factory; however, the manifold contains several components that you will need to install prior to securing the assembly to the A-frame.

- Each of the 12 HYDRAULIC HOSE PORTS on the MANIFOLD are covered with stretch wrap. Remove the wrap and install the appropriate fitting in its respective port.

*Note: All ports are identified by a stamped number on the manifold. The numbers also identify the hydraulic functions, which can be referenced on the label under the hydraulic pump and manifold cover (see page 7).*

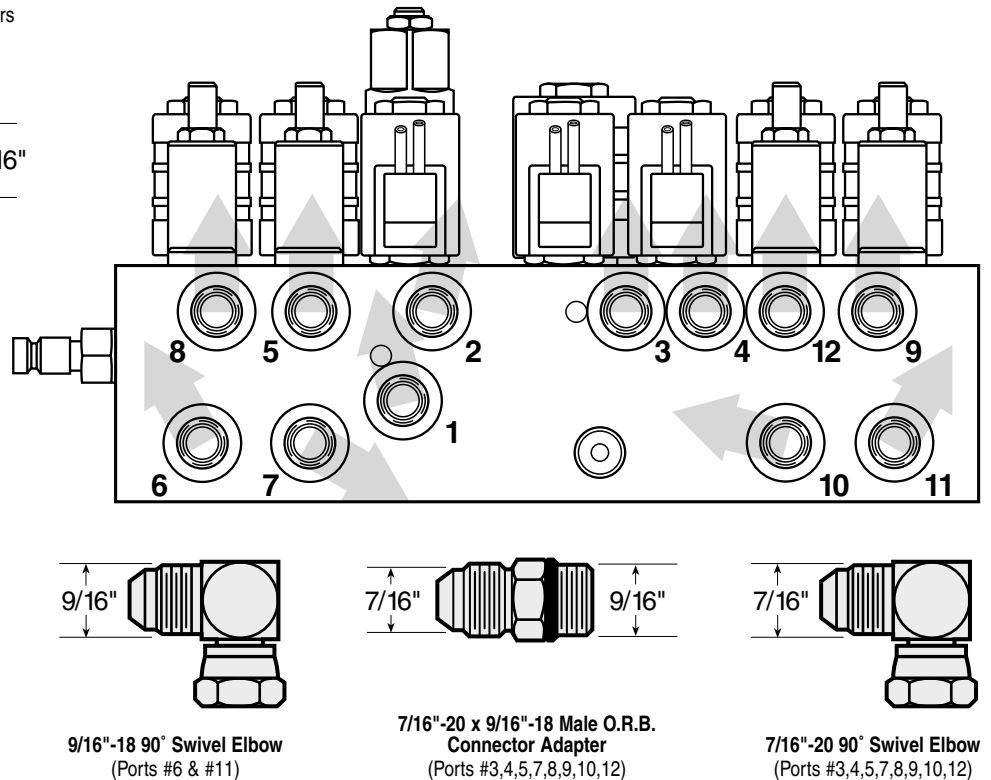



# Sequence Valve & Hydraulic Hose Identification Guide

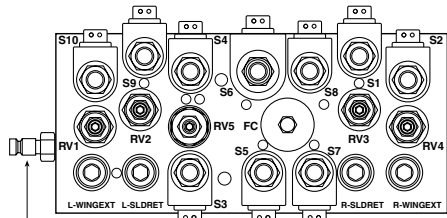

Pressure Gauge Quick Connect

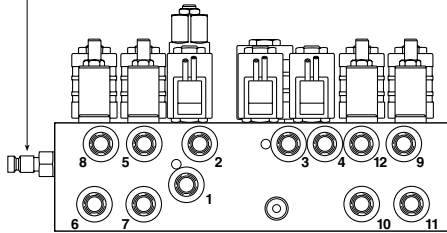

SEQUENCE VALVES	
Sequence Valve	Function
L-WINGEXT	Left Wing Cylinder Extend
L-SLDRET	Left Slide Cylinder Retract
R-WINGEXT	Right Wing Cylinder Extend
R-SLDRET	Right Slide Cylinder Retract
HYDRAULIC HOSES	
Port	Function
1	Right Angle - Left Cylinder
2	Left Angle - Right Cylinder
3	Raise - Lift Cylinder (Base)
4	Lower - Lift Cylinder (Rod)
5	Left Wing Retract
6	Left Wing Extend
7	Left Slide Box Retract
8	Left Slide Box Extend
9	Right Slide Box Extend
10	Right Slide Box Retract
11	Right Wing Extend
12	Right Wing Retract
RELIEF VALVES	
Valve	Function
RV1	Left Wing Pressure Relief
RV2	Left Wing Anti-Cavitation
RV3	Right Wing Anti-Cavitation
RV4	Right Wing Pressure Relief
RV5	Angle Relief
FC	Variable Flow Control Valve

**NOTE: Energize the following solenoids for the functions:**

S1	Right Slide Box Retract
S2	Right Slide Box Extend
S3	Angle Left - Right Cylinder
S4	Angle Right - Left Cylinder
S5 & S7	Float
S6 & S7	Raise
S8 & S8	Lower
S9	Left Slide Box Retract
S10	Left Slide Box Extend



Calumet, Michigan 49913 BLZ 1036

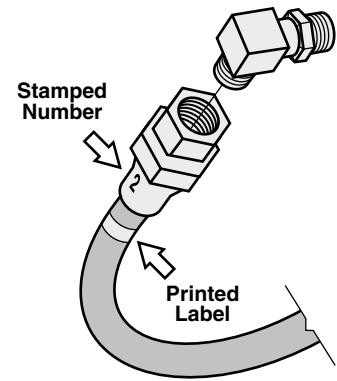

All of the hoses shipped with the snowplows contain either a stamped number on the sleeve or a printed label applied to the hose. All numbers, stamped or printed, correspond with the stamping of the ports on the manifold.

- Next, align the mount holes in the pump with the holes in the hinged bracket, located on the A-frame. *Note: To help facilitate the pump mount, first angle the hinged bracket as needed and tighten the bracket hardware, locking it in place.*



**CAUTION:** When installing the manifold between the mount brackets on the A-frame, hold the manifold at the sides of the block. Never handle the manifold by the wire lead coils. Doing so can cause a solenoid cartridge to bend, causing the cartridge to stick when activated.

Secure one 3/8"-16 x 3/4" hex cap screw and 3/8" flat washer through the top mount hole in the bracket and into the pump. Insert one 3/8"-16 x 1-1/2" threaded stud and jam nylon insert lock nut through the bottom mount hole in the bracket and into the pump. The threaded stud should bottom out in the pump.

- Once the pump and manifold assembly is in place, connect the hydraulic hoses to their respective adapters on the manifold. Remember, the labeling on the hydraulic hoses correspond with the stamped numbers on the manifold.

Begin installing the hoses with the driver's side slide box retract hose (#7). Continue installing hoses # 10, 1, 6, 11, 2, 5, 8, 3, 4, 12, and 9. Installing the hoses in this order will provide the best clearance for securing each hose to the manifold. *Note: All hoses, except #1 & #2 (angle cylinders) should be routed through the triangular openings in the A-frame.*

- Next, secure the manifold to the A-frame. Remove both 3/8" flat washers, 3/8" split lock washers and 3/8"-16 x 1" hex cap screws from the manifold and align the mount holes with the A-frame brackets. Position the DIODE PACK MOUNT BRACKET against the outside of the A-frame bracket on

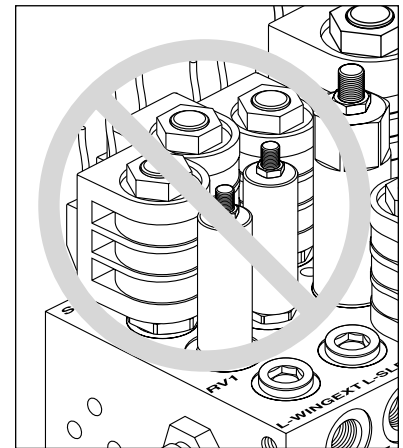

When installing the manifold between the mount brackets on the A-frame, **DO NOT** handle the manifold by the wire lead coils. The solenoid cartridges can bend, causing them to stick when activated. Always carry the manifold by the sides of the aluminum block.

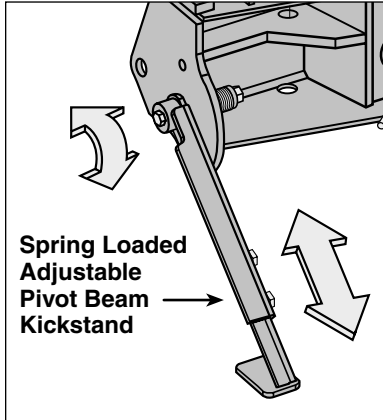
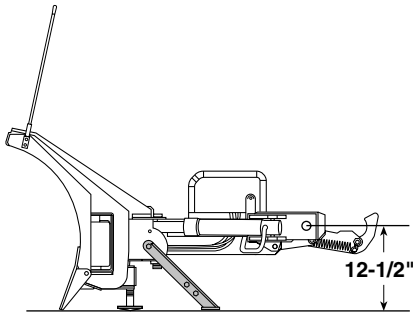

The kickstand is mounted to the side of the pivot beam with one 1/2"-13 x 4-1/2" hex cap screw and top lock nut. To pivot the kickstand, simply pull the spring loaded leg out and rotate it until the pin locks into place. The kickstand also has an adjustable foot that can be moved to accommodate varying vehicle heights. The proper height of your snowplow mounting points to level ground should be set at 12-1/2".

the driver's side. Note: Both of the prongs should be facing up. Align the outside hole on the diode bracket with the holes on the A-frame and manifold. Properly replace and tighten all hardware.

12. Hook each EXTENSION SPRING to the 3/4" diameter receiving holes located on the pivot beam and connect the opposite end of the spring to their respective SPADE BOLTS. Install the four 5/8"-11 x 6-11/16" spade bolts through the EXTENSION SPRING MOUNTING ANGLE on the top rear of the blade. Secure each spade bolt by placing one 5/8" flat washer on the bolt and thread one 5/8"-11 nylon insert lock nut. Tighten each lock nut until light appears between the coils of the spring.
13. Install the flexible BLADE GUIDES at the end of each plow wing. Insert the 5/16"-18 x 1" hex head screw through the holes provided at the top of the wing reinforcement rib. Tighten all screws using the nylon insert lock nuts provided.

## Electrical Assembly - Plow Harness

1. Begin the installation by connecting the RED POWER WIRE to the PUMP motor terminal using the hardware provided on the pump.
2. Place one 3/8" TOOTH LOCK WASHER, BLACK GROUND WIRE from the PLOW ELECTRICAL HARNESS and the RED GROUND WIRE on the COIL WIRE LEAD HARNESS, from the manifold, to the 3/8"-16 x 1" welded ground bolt on the A-frame. Secure both grounds to the A-frame with a 3/8"-16 top lock nut. *Note: If your plow only has a hole in the passenger's side A-frame angle, a 3/8"-16 x 1" bolt, nut and 3/8" tooth lock washer can be found in the packaged hardware kit.*
3. Remove the hex jam nut and external tooth lock washer from the POWER HITCH CONNECT/DISCONNECT TOGGLE SWITCH and insert it through the back of the mounting bracket on the A-frame. Align the notch in the key washer on the switch to the notch on the bracket. Replace the lock washer and jam nut and tighten until the switch is firmly in place. Next, attach the connector on the plow harness to the switch. *Note: Use caution when making the connection. Switches can break if done forcefully.*
4. Continue the harness installation by connecting the FEMALE ELECTRIC CONNECTOR on the harness to the MALE ELECTRIC CONNECTOR found on the coil wire lead harness attached to the manifold. *Note: If the plow harness you received contains a separate coil ground wire harness, disregard this part. The coils on the manifold are grounded to the A-frame. See step number two above.*
5. Finalize the harness installation by sliding the DIODE PACK over the diode pack mount bracket located behind the connect/disconnect toggle switch. Position the wire harness braid in the notch on the switch bracket and secure it with a nylon tie. The diode pack mount bracket contains an extra hole for a nylon tie. Use it to secure the pack from moving.
6. To install the PUMP & MANIFOLD COVER, position it over the rear brackets on the A-frame and align the notches in the cover with the welded bolts on the brackets. Secure the cover with two 3/8" washers and wing nuts. Verify the cover is positioned over the protective toggle switch hood. Pop the front of the cover on the threaded stud and secure it with one 3/8" washer and wing nut.

# Electrical Assembly - Vehicle Harness



**CAUTION:** Always perform the vehicle wire harness assembly with the vehicle off and the keys out of the ignition. Use caution when testing the electrical wires for the vehicle's headlight functions.

*Note: A new vehicle wire harness is being introduced for the 2001-02 season. This design contains a two piece harness connected by a headlight relay. The new design integrates the plow lights and power functions into the new rocker and joystick control stations and improves lighting.*

1. Begin the installation of the electrical harness under the hood. Insert the WHITE POWER CONNECTOR & RED POWER WIRE (with FUSE) end of the harness through the driver's side fire wall access panel into the vehicle cab. *Note: You may need to widen an opening or cut access to the cab interior to facilitate the assembly.*
2. Loosely position the remaining portion of the harness over the driver's side fender well and in front of the radiator core support. Position both of the large, gray VEHICLE HEADLIGHT CONNECTORS near the truck headlights and the smaller, black PLOW HEADLIGHT CONNECTORS near the grill of the vehicle.
3. Plug the 9 RECEPTACLES, from the vehicle harness that contain the gray headlight connectors, into the HEADLIGHT RELAY. See the illustration to the right. Connect the GREEN & YELLOW wire, from the vehicle harness with the molded power plug, to the remaining NEGATIVE spade on the relay. Securely mount the relay to the vehicle.
4. Proceed to remove the front directional light assembly on the driver's side of the vehicle. Feed the VIOLET, turn light wire and GRAY, run light wire from the wire harness through the opening in the directional light housing. At this point, use a test light or ohm meter to determine the proper wires in the vehicle's electrical system to splice into. Once you have identified the proper wires, position one end of the turn or run light wire into a SPLICE LOCK CONNECTOR provided. Attach the vehicle wire to the opposite side of the splice lock connector. Complete the splice by pinching both wires together and locking the connector. Repeat the splice procedure for the remaining wire. The passenger's side directional light assembly requires the same installation; however, only one wire, the PINK, turn light, needs to be spliced.
5. Connect the vehicle headlights to the vehicle wire harness using a headlight adapter kit. Due to differences in the construction of the adapter kits and the various make and model vehicles you will be servicing, the headlight adapter kits are not packaged with your snowplows. Review the list of available light adapters to the right. To place an order for headlight adapter kits, contact our Customer Service Department at 1-888-680-8600.

Begin the adapter kit installation by removing the existing vehicle headlight connector from the headlight. Attach the HEADLIGHT ADAPTER CONNECTOR to the existing vehicle headlight connector. Next, plug the BLACK, FIVE-PIN CONNECTOR on the headlight adapter into the gray, five-pin connector on the vehicle wire harness. Lastly, plug the HEADLIGHT ADAPTER CONNECTOR into the vehicle headlight receptacle. *Note: If more than one plug is present, match the colors of each connector (ie gray to gray, black to black, Chevrolet daylight running is clear to gray).* Repeat the installation for the opposite headlight.

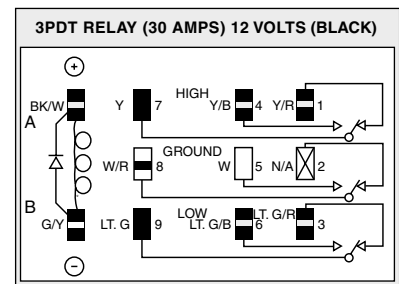

Connect the color coded wires from the vehicle harness to the headlight relay shown above. The wires correspond to the numbers/letters on the relay or the color abbreviations on the illustration.

- (-) G/Y= Green/Yellow Wire
- (+) BK/W = Black/White Wire
- (1) Y/R = Yellow/Red Wire
- (2) N/A = Not Applicable
- (3) LT.G/R = Light Green/Red Wire
- (4) Y/B = Yellow/Black
- (5) W = White
- (6) LT.G/B = Light Green/Black
- (7) Y = Yellow
- (8) W/R = White/Red Wire
- (9) LT.G= Light Green

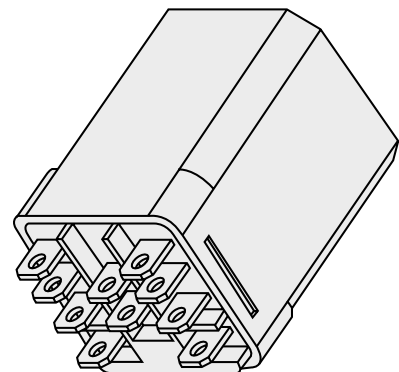

**AAS-3 Headlight Relay w/Surge Suppression**  
Blizzard P/N 62125  
Vendor P/N 90-9055-00-B-TR/SS

## Vehicle Headlight Adapter Kits

- 62010** 1980 & Older, 1983-1993 Dodge  
1995-1996 Chevrolet/GMC & Ford
- 62011** 1987-1992 Ford, 1991-2002 Dodge
- 62012** 1993-2002 Ford
- 62013** 1990-1999 GMC, 1991-1999 Chevrolet  
(Except '99 Chevrolet Silverado & '99 GMC Sierra)
- 62014** 1999-2002 Chevrolet Silverado & GMC  
Sierra with Daytime Running Lights
- 62015** 1989 Chevrolet
- 62050** 2000-2002 Dodge
- 62051** 1980 & Older Chevrolet/GMC, Dodge

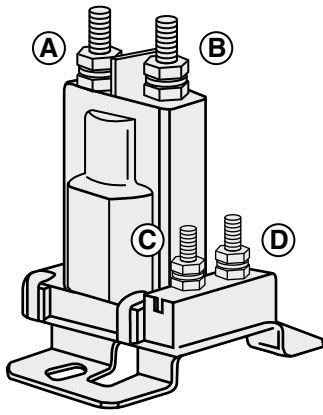

### Heavy-Duty Power Contactor

There are four wires that need to be attached to the power contactor:

- (A) 72" Red Power Battery Wire
- (B) Vehicle Wire Harness Red Power Wire
- (C) 24" Black Ground Wire
- (D) Brown/White Pump Solenoid Activation Wire

6. After the headlight adapters have been installed, attach the POWER CONTACTOR to the driver's side wheel well or engine fan guard using two 12-14 x 3/4" hex washer self-drilling screws. *Note: Some model vehicles provide mount locations for accessory components. The power contactor should be installed with the posts facing up. Angled installation may cause premature failure.* Connect the 24" BLACK GROUND WIRE to either small terminal on the contactor and attach the opposite end to the vehicle with one hex washer self-drilling screw. Locate the BROWN/WHITE PUMP SOLENOID ACTIVATION WIRE on the vehicle wire harness and position the eyelet over the remaining small terminal on the contactor. Secure it with the washer and nut provided.

7. Next, connect the BLACK VEHICLE WIRE HARNESS GROUND WIRE to the negative terminal on the vehicle's battery. The VEHICLE WIRE HARNESS RED POWER WIRE connects to either large terminal on the contactor. Complete the electrical connection by attaching the remaining 72" RED POWER BATTERY WIRE to the open terminal on the contactor. *Note: Depending on the location of the battery, you may need to shorten the red power wire. Upon determining the proper length, crimp the provided 3/8" END RING TERMINAL on the wire and connect it to the positive terminal on the battery.*

8. Once the connections to the battery are secured, proceed to fasten the SPLIT LOOM TUBING to the vehicle. Safely route all harness lengths around the engine components and attach them to the vehicle with nylon ties. Extend the PLOW HEADLIGHT CONNECTORS through the grill of the vehicle and position the HARNESS PLUG and WEATHER CAP near the bumper.



**CAUTION: Do not fasten the wire harness to areas that come in contact with moving engine parts or possess extreme heat. The harness could become tangled and/or melt causing electrical failure and vehicle damage.**

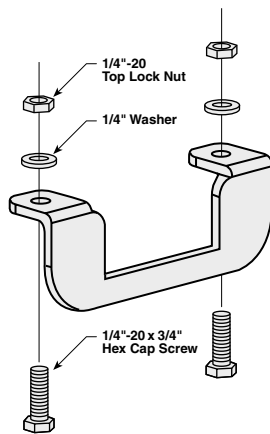

Vehicle Wire Harness Plug Mount Bracket

9. Locate a convenient position to mount the VEHICLE WIRE HARNESS PLUG MOUNT BRACKET near the driver's side bumper of the vehicle. This bracket will hold the plug to the vehicle when the snowplow is removed from the undercarriage. Position the bracket into the slot provided on the plug. Mount the bracket using two 1/4"-20 x 3/4" hex cap screws and secure with 1/4" washers and top lock nuts.

10. Return to the driver's side cab interior to install the remainder of the vehicle wiring harness. Connect the RED POWER WIRE (with 10 AMP FUSE) to a SWITCHED POWER SOURCE with a minimum of 10 amps. *Note: The red power wire MUST be fused and switched on and off with ignition. Secure all loose wires under the dash.*

11. Next, install the LIGHT TOWER. Position the tower arms into the receiving pockets located on the undercarriage push beam. (Review the proper undercarriage installation guidelines for your vehicle found near the back of the manual.) Align the mounting holes in the light tower with those on the push beam and insert two 1/2"-13 x 1-1/4" hex head cap screws. Secure the screws with 1/2" washers and top lock nuts.

12. Proceed to install the PLOW HEADLIGHTS. Align one HEADLIGHT BALL STUD MOUNT ADAPTER on the light tower tube with the mounting hole and insert the threaded stud through each. Secure the headlight with one 1/2" split lock washer and hex nut. *Note: All snowplows are shipped with two BLACK DOME PLUGS that install at either end of the light tower. For secure placement, apply a bead of silicone around the perimeter of the*

plug prior to installation on the light tower. Connect the terminals from the plow lights to the terminals on the vehicle wire harness. Repeat the installation for the opposite headlight.

- Next, position the **ROCKER SWITCH CONTROL STATION** on the front radius of the seat. Wrap the **VELCRO STRAP** around the bench, through the 2" metal D-ring and fasten. Finally, connect the white power connector from the vehicle wire harness to the connector on the control station. The power switch should be in the "MIDDLE" or "OFF" position.

*Note: All 2001-02 rocker switch control stations and joystick/rocker combination control stations have an integrated plow light switch. These controls work specifically with the vehicle harnesses that contain the headlight relay. In addition, the operation of the draw latch can only be controlled when the power switch is located in the "UP" position. See the diagram to the right.*

*If you have a rocker switch control station that does not contain the integrated plow light switch, and you have the vehicle harness that contains the headlight relay, you can easily connect a plow headlight toggle switch. The vehicle harness has a small, two pin connector located near the main power connector. Use the **PLOW HEADLIGHT SWITCH 2-PIN CONNECTOR & WIRE LEADS** to connect a plow headlight toggle switch to the harness.*

*First, insert the 24" **GREEN/YELLOW GROUND LEAD** into the 2-pin power connector. This lead should be grounded to the vehicle. Next, plug both of the 1/4" receptacles, on the **HEADLIGHT TOGGLE SWITCH LEAD**, into the switch. Note: Both receptacles should be inserted into the spades on same side of the switch. One receptacle should be positioned in the middle spade. See the illustration below. Complete the connection by plugging both 2-pin connectors together. See the diagram on page 32.*

This completes the electrical assembly installation for the vehicle wire harness. You are now ready to perform all of the test functions on the snowplow.

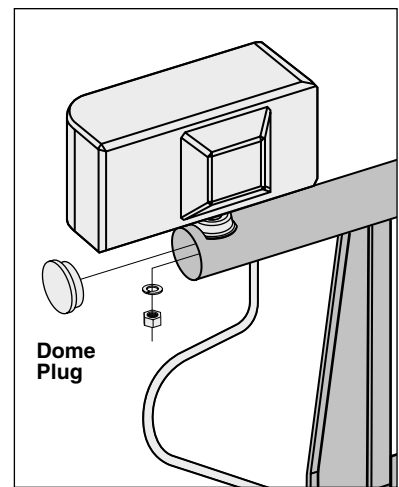
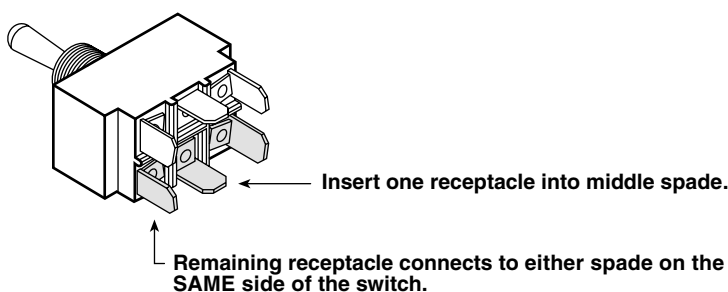

Apply a thin bead of silicone around the inside perimeter of the molded nylon dome plugs prior to capping the light tower ends. The silicone will help retain the plug inside of the light tower mount tube.

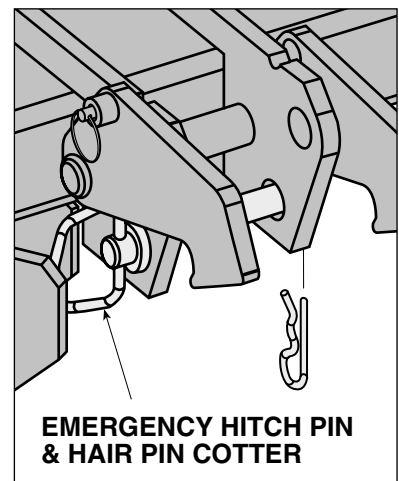
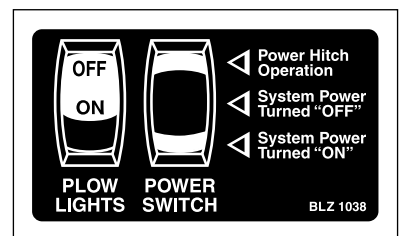

In the event you should lose hydraulic power while snowplowing, raise the snowplow into a pile of snow and insert the emergency hitch pin. The pin will lock the plow in a temporary raised position until proper service can be performed to restore hydraulic power.



Once all of the hydraulic functions have been executed, the system will have been filled with approximately 4-1/2 quarts of hydraulic oil.



## Testing The Snowplow

1. Fill the HYDRAULIC PUMP FLUID RESERVOIR with BLIZZARD SNOWPLOW RAPID ACTION HYDRAULIC OIL (P/N 60138) until it is 3/4" from the top of the tank. Replace the cap on the reservoir. Proceed to remove the weather caps from each of the plow and vehicle wire harnesses and connect the plugs. Start the vehicle and turn the POWER SWITCH on the control station in the cab to the "ON" position. You now have power to the snowplow.
2. To raise the DRAW LATCH on the snowplow, turn the power switch on the control station to the "UP" or "ON" position. Push and hold the toggle switch on the A-frame upward into the "CONNECT" position. Notice the action of the fluid in the reservoir. By activating the initial hydraulic function, the fluid begins to fill the system. Push and hold the toggle switch in the "DISCONNECT" position, the draw latch will lower. Refill the reservoir until the fluid is 3/4" from the top of the tank.
3. Position the vehicle such that the draw latch is below the push beam and the mounting points on the A-frame are in line with the mounting points on the undercarriage. Pull out the A-FRAME LATCH PIN and rotate the A-FRAME LATCH clockwise until the latch is resting on the DRAW LATCH BOLT MOUNT PIN (See diagram on page 13). Move the snowplow in position by activating the draw latch CONNECT switch and release.



**WARNING: Always use caution when operating the draw latch CONNECT/DISCONNECT switch. Keep your hands and feet away from the operation of the draw latch and the main blade. The action of the draw latch moves the snowplow in position for proper attachment to the vehicle. Failure to follow this caution may result in serious injury or death.**

The draw latch will raise until it hits the push beam and the DRAW LATCH FINGERS will pull the plow into the vehicle. The mounting points on the plow and vehicle are now positively aligned. Rotate the A-frame latch counterclockwise until the latch is in the raised position. Insert the two HITCH PINS through the mounting holes on the A-frame and secure each with one hair pin cotter. The snowplow is now securely mounted to the vehicle.

4. Return to the interior of the vehicle. With the plow securely in place, you can now execute the remaining functions of the snowplow. The system power on the control station should be in the "ON" position. Next, raise the plow to its maximum height by pushing and holding the "RAISE" rocker switch on the control station. Initiate the driver's side wing by pushing and holding the "LEFT WING EXTEND" rocker switch until the wing pivots forward. Notice the staggered pace the wing extends. The hydraulic fluid is filling the hose and replacing the air in the system. Push and hold the "LEFT WING RETRACT" rocker switch to return the wing. Continue testing the remaining rocker switch functions. Monitor the fluid level in the reservoir and fill to 3/4" from the top of the tank if needed. Also, look for any automatic transmission fluid leaks around the manifold, pump, hydraulic hoses and all cylinders.
5. Lastly, check that the vehicle and plow headlights are in proper working condition including the turn signals. If necessary, adjust the plow headlight beams with the plow in the raised position.

Congratulations on a successful assembly and installation! Once all of the blade and electrical functions have been tested your Blizzard Power Plow is ready for action. Should you need additional support during a plow assembly or undercarriage installation, contact our Customer Service Department toll-free at 1-888-680-8600.

# MOUNTING & DISMOUNTING INSTRUCTIONS

Prior to operating your Power Plow, review the Mounting & Dismounting Instructions label at the driver's side rear of the moldboard (shown below).



## MOUNTING & DISMOUNTING INSTRUCTIONS

### MOUNTING

1. Position vehicle close to the plow and align mounting points on the undercarriage and A-frame. Verify that the plow kickstand is in the lowered position. Turn vehicle ignition off.
2. Turn power supply switch on the main plow control unit in the vehicle to the "OFF" position.
3. Remove protective weather caps and make electrical connection at the plow and vehicle.
4. Turn the vehicle ignition and the power supply switch on the control unit to the "ON" position. Pull the A-frame latch lock pin outward and verify that the A-frame latch lowers over the draw latch extension spring mount.
5. Activate the Power Hitch on the A-frame by pushing and holding the "CONNECT/ DISCONNECT" switch (on the pump cover housing) upward. **CAUTION: Keep fingers away from plow and truck mounting points. Power Hitch will automatically pull the plow into the receiving points on the truck when activated.** Insert both hitch pins through the positively aligned holes on the plow and undercarriage and secure each with a hair pin cotter.
6. With the plow securely mounted, slightly lower the Power Hitch to relieve tension on the A-frame latch, pull the latch lock pin and raise the A-frame latch until it locks into position. Raise the Power Hitch and verify that the draw latch is fully engaged behind the push beam on the vehicle. Rotate the kickstand counterclockwise until it locks into place. The plow is now properly mounted and ready to operate.

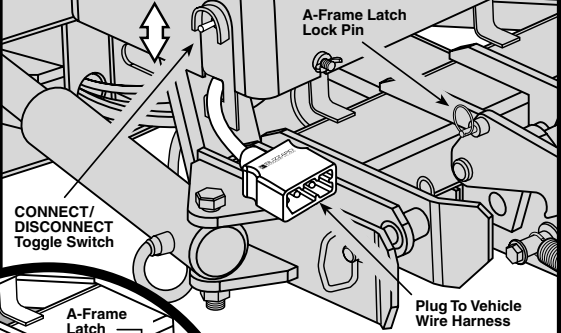

### DISMOUNTING

1. Lower the plow on a flat, level surface to dismount. Turn vehicle ignition off.
2. Pull the kickstand lock pin outward and rotate the kickstand clockwise. Release the pin to lock kickstand in place. Remove both hitch pins from the A-frame and undercarriage.
3. Turn the vehicle ignition and the power supply switch on the control unit to the "ON" position. Activate the Power Hitch by pushing and holding the "CONNECT/DISCONNECT" switch downward. **CAUTION: Keep fingers away from plow and truck mounting points.** Verify that the draw latch is fully disengaged from behind the push beam on the vehicle.
4. Turn power supply switch on the main plow control unit in the vehicle to the "OFF" position.
5. Disconnect wire harnesses at the plow and vehicle. Replace protective weather caps.

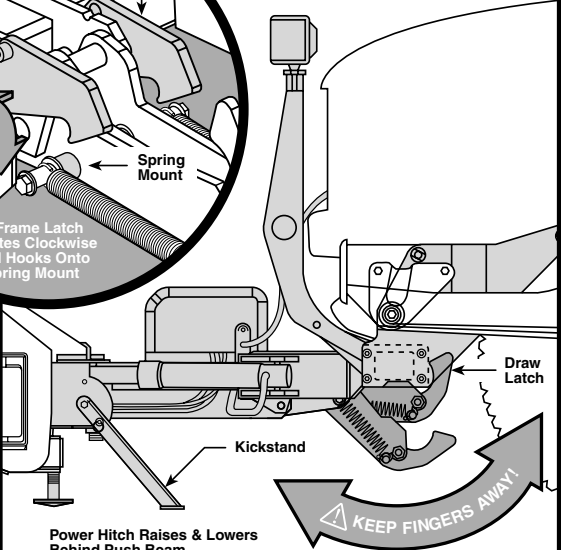

BLZ 1023

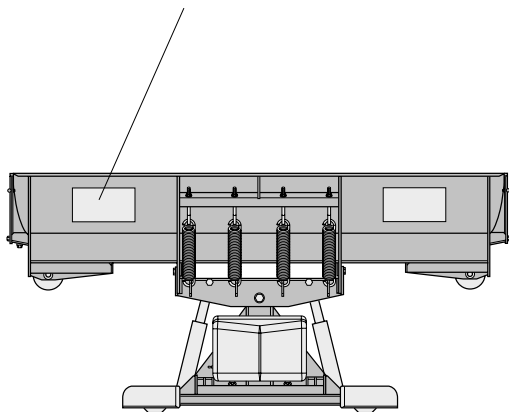

Should the Mounting & Dismounting Instructions label or any of the labels that came with your snowplow become hard to read or wear off, contact your local dealer or call our Customer Service Department at 1-888-680-8600 for replacements.







# PLOW SPECIFICATIONS

## Moldboard

Length .....	8'
Thickness .....	12 Gauge
Height .....	29"
Reinforcement .....	4 Ribs @ 1/4"
Cutting Edge .....	1/2" x 6" (1080)
Finish.....	Powder Coat - White

## Wings

Length .....	12'
Thickness .....	12 Gauge
Height .....	29"
Reinforcement .....	1 Rib each @ 1/4"
Cutting Edge .....	1/4" x 10" (T1)
Finish.....	Powder Coat - White

## Trip Mechanism

Trip Spring Type .....	(4) 3/8" Hooked Extension
Trip Spring Adjustment .....	5/8"-11 x 6-11/16" Spade Bolt

## A-frame

Material .....	Rec. Tube & Channel Type
Hitch Pins.....	3/4" x 4-3/4" Yellow Zinc
Emergency Hitch Pin .....	1" x 5-3/4" Yellow Zinc
Finish.....	Powder Coat - Black

## Pump

Construction .....	Steel Housing w/Clear Plastic Tank
Type .....	Internal Gear Pump
Motor.....	12 V Starter
Volume Per Minute .....	2.1 GPM @ 1500 PSI
Weight .....	32 lb.
Mount.....	A-frame Install w/Hex Head Screws
Reservoir Capacity.....	1.5 quarts
Controls .....	Toggle Switch & Joystick

## Manifold

Construction .....	Red Anodized Aluminum
Ports.....	12
Cartridge Valves.....	10
Relief Valve.....	5
Flow Control Valve .....	1
Weight .....	28.5 lb.
Mount.....	A-frame Install w/Hex Head Screws
Maximum Flow Capacity .....	3.5 gpm

## Cylinders

<i>Angle Cylinders</i> .....	2
Stroke .....	10"
Ram Diameter.....	1-3/4"
Bore Diameter.....	2"

<i>Lower/Raise Cylinder</i> .....	1
Stroke .....	4-21/32"
Ram Diameter.....	1-1/4"
Bore Diameter.....	2-1/2"

<i>Slide Box Cylinders</i> .....	2
Stroke .....	12"
Ram Diameter.....	1"
Bore Diameter.....	1-1/2"

<i>Wing Cylinders</i> .....	2
Stroke .....	2"
Ram Diameter.....	1-1/8"
Bore Diameter.....	1-3/4"

## Plow Headlights

Type .....	Low Profile w/Turn Signals
Measurements .....	10-3/4" W x 5"H x 5-3/2"D
Housing .....	Plastic Composite
Mount .....	Adjustable Ball Type
Bulb Type .....	High/Low Sealed Beam Halogen, 12V Rect.
Switch Type .....	Integrated On/Off Control Station Switch

## Miscellaneous

Plow Weight .....	Approx. 950 lb.
Compact Plow Width .....	8'
WidePass™ Plow Width .....	10'
BucketBlade™ Plow Width .....	9'-3"
Adjustable Plow Shoes.....	(2) Heavy-Duty Cast Steel
Mount Mechanism .....	Hydraulic Draw Latch
Standard Control Station .....	Rocker Switch
Optional Control Station.....	Joystick/Rocker Switch

## MODEL 810 PARTS LIST

Ref. No.	Part Number	Qty.	Part Description
1	52060	1	Moldboard
2	51045	1	Wing Weldment - Driver's Side
3	51049	1	Wing Snow Shield - Driver's Side
4	50060	1	Slide Box Weldment - Driver's Side
5	51046	1	Wing Weldment - Passenger's Side
6	50061	1	Slide Box Weldment - Passenger's Side
7	51050	1	Wing Snow Shield - Passenger's Side
8	61213	6	#11 Aluminum Buttonhead Rivet
9	51047	1	Wing Cutting Edge Weldment (T1) - Passenger's Side
10	61292	1	Moldboard Cutting Edge (1080)
11	51048	1	Wing Cutting Edge Weldment (T1) - Driver's Side
12	61315	7	1/2"-13 x 1-3/4" Flat Head Socket Cap Screw
13	61318	2	1/2"-13 x 6" Flat Head Socket Cap Screw
14	61317	2	1/2"-13 x 5" Flat Head Socket Cap Screw
15	61021	2	1/2"-13 x 3-1/2" Flat Head Socket Cap Screw
16	61026	19	1/2", 1-1/16" O.D., 17/32" I.D. YZ SAE Mil-Carb High-Strength Washer
17	61020	18	1/2"-13 Grade C Z Top Lock Nut
<b>18A</b>	<b>61049</b>	<b>2</b>	<b>Plow Guide Assembly: (1) - 18 &amp; 19, (2) - 20 &amp; 21</b>
18	61113	2	Plow Guide Tip, Black
19	61050	2	27-1/4" Plow Guide, Red
20	61051	4	5/16"-18 x 1" Grade 5 Z Hex Head Cap Screw
21	61052	4	5/16"-18 Z Nylon Insert Lock Nut
22	51009	2	3/4" x 9" Wing/Slide Box Pivot Pin
23	50013	2	3/4" x 3-3/8" Hydraulic Cylinder Rod End Pin - Wing Angle
24	60090	2	Hydraulic Cylinder - Wing Angle
25	61028	12	1/4" x 1-1/4" Spring Pin
26	50012	2	3/4" x 4" Hydraulic Cylinder Base End Pin - Wing Angle
27	50011	2	5/8" x 4" Hydraulic Cylinder Rod End Pin - Slide Box Extend/Retract
28	61316	4	3/16" I.D., 1-1/4" O.D. Z Fender Washer
29	50056	1	Slide Box Polyurethane Wiper Blade - Driver's Side
30	50055	1	Slide Box Polyurethane Wiper Blade - Passenger's Side
31	61198	2	5/8" DIA. x 1-1/8" Rubber Cap, Black
32	52012	2	5/8" x 7-5/16" Hydraulic Cylinder Base End Pin - Slide Box Extend/Retract
33	61030	4	1/8" DIA. x 2-5/8" Z Hair Pin Cotter
34	60031	1	Hydraulic Cylinder - Slide Box Extend/Retract, Passenger's Side
35	60097	1	1/4" x 34" Hydraulic Hose (#9) - Slide Box Extend, Passenger's Side
36	60098	1	1/4" x 42" Hydraulic Hose (#10) - Slide Box Retract, Passenger's Side
37	60004	3	7/16"-20 x 7/16"-20 Male O.R.B. Connector Adapter
38	60008	2	7/16"-20 x 7/16"-20 90° Adjustable Elbow O.R.B. Adapter
39	60060	1	Hydraulic Cylinder - Slide Box Extend/Retract, Driver's Side
40	60099	1	3/8" x 84" Hydraulic Hose (#11) - Wing Extend, Passenger's Side
41	60006	4	9/16"-18 90° Swivel Elbow Adapter
42	60189	1	1/4" x 88" Hydraulic Hose (#12) - Wing Retract, Passenger's Side
43	60009	10	7/16"-20 90° Swivel Elbow Adapter
44	60003	10	7/16"-20 x 9/16"-18 Male O.R.B. Connector Adapter
45	60007	4	9/16"-18 x 9/16"-18 Male O.R.B. Connector Adapter
46	60094	1	1/4" x 84" Hydraulic Hose (#5) - Wing Retract, Driver's Side
47	60095	1	3/8" x 84" Hydraulic Hose (#6) - Wing Extend, Driver's Side
48	60016	1	1/4" x 40" Hydraulic Hose (#7) - Slide Box Retract, Driver's Side
49	60188	1	1/4" x 34" Hydraulic Hose (#8) - Slide Box Extend, Driver's Side
<b>50A</b>	<b>61130</b>	<b>2</b>	<b>Slide Box Access Plate Assembly: (1) - 50 &amp; 51</b>
50	52014	2	Slide Box Access Plate
51	61100	2	9-3/4" Trim-Lok
52	61037	6	1/4"- 20 x 3/4" Grade 8 YZ Hex Cap Screw
53	61215	4	1/4"- 20 U-Nut
54	61099	4	3/8" x 2-5/16" O.D. x 14-1/2" Extension Spring
55	61187	4	5/8"-11 x 6-11/16" Grade 8 Z Clear Chromate Spade Bolt
56	61064	4	5/8", 1-5/16" O.D., 21/32" I.D. YZ SAE Mil Carb High-Strength Washer
57	61188	4	5/8"-11 Nylon Insert Lock Nut - Type NE
<b>58A</b>	<b>61220</b>	<b>2</b>	<b>Heavy-Duty Plow Shoe Assembly: (1) - 58, 59, 61, (18) - 60</b>
58	61221	2	Cast Iron Heavy-Duty Plow Shoe (8-3/8" Shaft)
59	61102	2	1-5/8" O.D., 1-1/8" I.D. x 1-1/2" YZ Spacer
60	61101	36	1", 1-3/4" O.D., 1-1/16" I.D. Z Flat Washer
61	61103	2	1/2" x 1-3/4" Linch Pin
62	61152	1	1/2"-13 x 4-1/2" Grade 8 YZ Hex Cap Screw
63	41047	1	Kickstand Foot Weldment
64	41038	1	Kickstand Leg Weldment
65	61057	4	1/2"-13 x 1-1/4" Grade 8 YZ Hex Cap Screw
66	61293	1	1-1/8" O.D. x 53/64" I.D. x 2" Compression Spring

*Note: The reference numbers listed identify parts shown in the illustration on pages 21-23. These numbers are specific to these illustrations only and do not correspond with other diagrams in the manual. Always review the part number given for proper component identification.*

## MODEL 810 PARTS LIST

Ref. No.	Part Number	Qty.	Part Description	
67	41037	1	3/8" x 1-1/8" O.D. x 35/64" I.D. Stepped Bushing	<i>Note: The reference numbers listed identify parts shown in the illustration on pages 21-23. These numbers are specific to these illustrations only and do not correspond with other diagrams in the manual. Always review the part number given for proper component identification.</i>
68	61314	2	3/4"-10 x 3-1/2" (with 2-1/2" Shank) Grade 8 YZ Hex Cap Screw	
69	61006	8	3/4"-10 Grade C Z Top Lock Nut	
70	61002	4	3/4"-10 x 5" Grade 8 YZ Hex Cap Screw	
71	61131	1	1"-8 x 9" Grade 8 YZ Hex Head Cap Screw	
72	61008	1	1"-8 Grade C Z Top Lock Nut	
73	61217	2	1-1/2" I.D., 2-1/8" O.D. Rubber Grommet, 60 Durometer	
74	41041	1	Pivot Beam Weldment	
75	60029	2	Hydraulic Cylinder - Plow Angle	
76	60005	3	9/16"-18 x 9/16"-18 90° Adjustable Elbow O.R.B. Adapter	
77	60091	1	3/8" x 24" Hydraulic Hose (#1) - Plow Angle, Driver's Side	
78	60011	1	3/8" x 24" Hydraulic Hose (#2) - Plow Angle, Passenger's Side	
79	61005	1	3/4"-10 x 6" Grade 8 YZ Hex Cap Screw	
80	60092	1	1/4" x 17" Hydraulic Hose - Str./45° (#3) - Plow Raise / Lower, Extend	
81	60002	1	7/16"-20 x 7/16"-20 45° Adjustable Elbow O.R.B. Adapter	
82	60027	1	Hydraulic Cylinder - Plow Raise / Lower	
83	60093	1	1/4" x 15" Hydraulic Hose - Str./45° (#4) - Plow Raise / Lower, Retract	
84	61053	1	3/16" x 1-11/16" O.D. x 12" Z Compression Spring	
85	61032	2	1-1/4", 2-1/2" O.D., 1-3/8" I.D. YZ SAE Mil-Carb High-Strength Washer	
86	61017	3	3/8"-16 Z Wing Nut	
87	61012	3	3/8"-16 x 3/4" Grade 8 YZ Hex Cap Screw	
88	61016	6	3/8", 13/16" O.D., 13/32" I.D., YZ SAE Mil-Carb High-Strength Washer	
89	61014	1	3/8"-16 Z Jam Nylon Insert Lock Nut - Type NTE	
90	61116	1	3/8"-16 x 1-1/2" Threaded Stud	
91	40004	1	Pump Mount Hinge Weldment	
92	61218	1	3/8"-16 x 2" Grade 8 YZ Hex Cap Screw	
93	61034	2	3/8"-16 Grade C Z Top Lock Nut	
94	61307	1	3/8" Internal/External Tooth Lock Washer	
95	61033	3	3/8"-16 x 1" Grade 8 YZ Hex Cap Screw	
96	61222	2	3/8" YZ High Alloy Split Lock Washer	
97	62019	2	7/16"-14 Hex Jam Nut	
98	61223	1	7/16" Internal Tooth Lock Washer	
99	61224	1	7/16", 15/32" I.D., 23/32" O.D. Key Washer	
100	62038	1	DPDT, (On)-Off-(On) Toggle Switch, 16 Amps, 115V AC - Draw Latch Connect/Disconnect	
101	82047	1	Diode Pack Mount Bracket	
102A	40106	1	<b>A-frame Assembly: (1) - 91-93, 102, 110-112, 183, (2) - 109, (4) - 107, 108</b>	
102	40090	1	A-frame Weldment	
103	61115	2	3/4" x 4-3/4" YZ Hitch Pin	
104	61105	2	9/64" DIA. x 2-11/16" Z Hair Pin Cotter	
105	61197	1	1" x 5-3/4" YZ Emergency Hitch Pin	
106	61226	1	11/64" DIA. x 3-3/4" Z Hair Pin Cotter	
107	61312	4	5/16"-18 x 3/4" Grade 8 YZ Hex Head Cap Screw	
108	61011	6	5/16" YZ High-Alloy Split Lock Washer	
109	40088	2	Replaceable A-frame Pivot Bushing	
110	40079	1	3/8" x 1-3/4" Stainless Steel A-frame Latch Pin	
111	61000	1	1/32" x 3/8" O.D. x 15/16" Stainless Steel Compression Spring	
112	61309	1	1-41/64" O.D., 1-25/64" I.D. Standard Split Ring	
113A	40083	1	<b>Draw Latch Assembly: (1) - 69, 118-121, 125, 127-130, (2) - 16, 87, 113, 114, 116, 117, 122-124, 126, (4) - 115</b>	
113	61018	2	1/2"-13 x 2" Grade 8 YZ Hex Head Cap Screw	
114	61045	2	1/8" x 1-1/4" O.D. x 6" Stainless Steel Extension Spring	
115	61297	4	3/8", 1-1/16" O.D., 25/64" I.D. Z Flat Washer	
116	40039	2	3/4" O.D., 17/32" I.D. x 1-3/16" YZ Bushing	
117	61027	2	1/2", 1-3/8" O.D., 9/16" I.D., YZ USS Mil-Carb High-Strength Washer	
118	61004	1	3/4"-10 x 4-1/2" Grade 8 YZ Hex Cap Screw	
119	40041	1	3/4" x 7" Draw Latch Spring Mount Pin (3/8"-16 Tap In Each End)	
120	40080	1	Outer Draw Latch Plate Weldment - Driver's Side	
121	61227	1	1/4"-20 x 1/2" Set Screw	
122	40074	2	Inner Draw Latch Plate	
123	40031	2	Draw Latch Arm	
124	40042	2	3/4" x 2-1/2" Inner Draw Latch Plate / Hydraulic Cylinder Rod End Pin - Plow Raise/Lower	
125	40068	1	1" x 6" Draw Latch Bolt Mount Pin (1/2"-13 Tap In Each End)	
126	40092	2	1-7/16" O.D., 13/16" I.D. x 1/2" YZ Bushing	
127	40082	1	Draw Latch Finger Weldment	
128	40093	1	1-1/4" O.D., 1-1/16" I.D. x 1-1/2" YZ Bushing	
129	40070	1	1" x 4-1/2" Draw Latch Mount Pin (To A-frame)	
130	40081	1	Outer Draw Latch Plate Weldment - Passenger's Side	
131A	60101	1	<b>Hydraulic Pump Assembly (Fenner Fluid Power): (1) - 131-134</b>	
131	60047	1	Hydraulic Pump Power Unit (Fenner Fluid Power)	
132	60044	1	Hydraulic Pump Pressure Relief Valve Hex Cap (Fenner Fluid Power)	

## MODEL 810 PARTS LIST

Ref. No.	Part Number	Qty.	Part Description
133	60045	1	Hydraulic Pump Fluid Reservoir (Fenner Fluid Power)
134	60046	1	Hydraulic Pump Fluid Reservoir Cap (Fenner Fluid Power)
135	61129	1	1/4" Polyethylene Hydraulic Pump & Manifold Cover
136	60038	2	3/32" C.S.W., 9/16" I.D., 3/4" O.D. Neoprene O-ring, 70 Durometer
<b>137A</b>	<b>60159</b>	<b>1</b>	<b>Manifold Assembly: (1) - 76, 137, 141, 143, 145A, 149, 150, 152, 153, (2) - 41, 45, 147, 148, 154, (3) - 140,142, (4) - 138, 139, (6) - 144, (8) - 43, 44, (10) - 146</b>
137	60174	1	Red Anodized Aluminum Manifold Block with Cross Port Relief
138	60176	4	Relief/Anti-Cavitation Valve, 1000 PSI (32000079)
139	60178	4	Seat Insert
140	60050	3	-6 SAE Hollow Hex Plug
141	60072	1	9/16"-18 x 9/16"-18 Male Extra Long Elbow
142	60049	3	-4 SAE Hollow Hex Plug
143	60173	1	7/16"-20 O.R.B. Test Port Coupling
144	60167	6	Four-Way, Two Position C.C. Spool Valve (86020464)
<b>145A</b>	<b>62120</b>	<b>1</b>	<b>Coil Harness Assembly: (1) - 151, 62045, 62118, (9) - 145, (10) - 62096, 62097</b>
N/A	62045	1	Plastic Electric Connector - Male
N/A	62096	20	Silicone Cable Seal, Orange (18 AWG)
N/A	62097	10	Male Terminal (18-16 AWG)
N/A	62118	1	3/8" I.D. Copper End Ring Terminal, 6 Gauge - Coil Harness
145	62114	9	Coil, PDL 10V DC
146	60052	10	1/2"- 20 YZ Hex Jam Nut
147	60175	2	Relief Valve, 1700 PSI (86020465)
148	60177	2	Relief Valve, 1500 PSI (86020466)
149	60168	1	Relief Valve, 3000 PSI (85020340)
150	60170	1	Three-Way, Two Position Spool Valve (85020341)
151	62115	1	Coil, DDL 10V DC
152	60166	1	Three-Way, Two Position Spool Valve (86020463)
153	60169	1	Flow Control Valve (85002054)
154	60165	2	Two-Way N.C. Valve (86020190)
155	61010	2	5/16"-18 x 3-3/4" Grade 8 YZ Hex Cap Screw
<b>156A</b>	<b>62112</b>	<b>1</b>	<b>Vehicle Wire Harness Assembly - Relay Version (2001-02): (1) - 156, 157, 62008, 62009, 62113, 62124, (2) - 62035, 62072, (3) - 62016</b>
156	62111	1	Vehicle Wire Harness - Relay Version (2001-02)
157	62000	1	Rubber Weather Cap - Vehicle Wire Harness
N/A	62035	2	Rubber Weather Cap - Plow Headlight Connector
N/A	62124	1	1/4" DIA. x 1-1/4" BUSS AGC 15A, 32V Fuse
N/A	62113	1	Main Lighting Harness - Relay Version (2001-02)
N/A	62125	1	3PDT, Headlight Relay w/Surge Suppression, 30A, 12V (90-9055-00-B-TR/SS)
N/A	62126	1	24" Ground Lead (Green/Yellow Wire) with #10 Ring Terminal
N/A	62127	1	24" On/Off Plow Light Switch Lead (Green/Yellow Wires) with Two 1/4" Receptacles
N/A	61031	6	12-14 x 3/4" Hex Washer Self-Drilling Screw
N/A	62049	1	72" Power Cable, Red - Power Contactor to Battery
N/A	62072	4	3/8" I.D. Copper End Ring Terminal, 4 Gauge - Vehicle Harness / 72" Power Cable
N/A	62008	1	Mini Fuse Clip
N/A	62009	1	Auto Blade Fuse Clip
N/A	62016	3	Splice Lock Connector (18-14 AWG)
N/A	62042	1	Heavy Duty, Water-Resistant DC Power Contactor
N/A	61228	4	5/16"-24 Z Hex Jam Nut
N/A	61229	4	#10-32 Z Hex Full Nut
N/A	61230	2	#10 Z Medium Split Lock Washer
N/A	62056	1	24" Ground Wire - Power Contactor
<b>158A</b>	<b>62039</b>	<b>1</b>	<b>Plow Wire Harness Assembly (2000-02): (1) - 98-100, 158, 159, 62006, 62046, (2) - 97, (10) - 62093, 62096</b>
158	62057	1	Plow Wire Harness
159	62001	1	Rubber Weather Cap - Plow Wire Harness
N/A	62046	1	Plastic Electric Connector - Female
<b>N/A</b>	<b>62006</b>	<b>1</b>	<b>Diode Board Assembly - Plow Wire Harness: (1) - 62007, 62090, 62092, 62094, 62095, (5) - 62091, 62093</b>
N/A	62007	1	Diode Board Cover, Clear
N/A	62090	1	Diode Board Connector Body w/Gasket
N/A	62091	5	Silicone Cable Seal, Green (16 AWG)
N/A	62092	1	Silicone Cavity Plug, Green (16 AWG)
N/A	62093	15	Female Terminal (18-16 AWG)
N/A	62094	1	Circuit Board (MPM-90-8315-00)
N/A	62095	1	Six-Way Secondary Lock
<b>160A</b>	<b>62058</b>	<b>1</b>	<b>Plow Headlight Assembly: (1) - 160/161-165, 62061, 62062</b>
160	62059	1	Plow Headlight - Driver's Side
161	62060	1	Plow Headlight - Passenger's Side
162	62032	2	Plow Headlight Wire Harness with 5-pin Plug
N/A	62061	2	Plow Headlight Glass Sealed Beam Halogen Bulb (H6545/H4666)
N/A	62062	1	NYK Corrosion Preventive Compound (2 fl.oz.)

*Note: The reference numbers listed identify parts shown in the illustration on pages 21-23. These numbers are specific to these illustrations only and do not correspond with other diagrams in the manual. Always review the part number given for proper component identification.*

## MODEL 810 PARTS LIST

Ref. No.	Part Number	Qty.	Part Description
163	61231	2	Headlight Ball Stud Mount Adapter
164	61232	2	1/2" Heavy Split Lock Washer
165	61025	2	1/2"-13 Grade 8 YZ Hex Nut
166	61166	2	2-1/4" Molded Nylon Dome Plug, Black
167	39032	1	Light Tower, Round Mounting Tube
168	61038	2	1/4"-20 Grade C Z Top Lock Nut
169	61039	2	1/4", 5/8" O.D., 9/32" I.D. YZ SAE Mil-Carb High-Strength Washer
170	39023	1	Stainless Steel Vehicle Wire Harness Plug Mount
<b>171A</b>	<b>62128</b>	<b>1</b>	<b>Rocker Switch Control Station Assembly - Relay Version: (1) - 171-175, 177, 178, 180, 181, (3) - 176, (4) - 179, 61036</b>
171	61125	1	1/8" ABS Plastic Rocker Switch Control Station Housing
172	62065	1	SPST, Off-None-On Rocker Switch, Black/Red 15A, 250V AC (Power - Plow Lights)
173	61126	1	1/8" ABS Plastic Rocker Switch Control Station Housing Plate
174	61127	1	61" Velcro Strap with 2" Metal D-Ring, Black
175	62130	1	Electrical Connector (12-pin & 2-pin Plugs) - Rocker Switch Control Station - Relay Version
176	62066	3	DPDT, (On)-Off-(On) Rocker Switch, White 10A, 250V AC (Wing Extend & Retract - Driver's Side & Passenger's Side, Plow Angle)
177	62129	1	SPDT, On-Off-On Rocker Switch, Black 10A, 250V AC (System Power On - System Power Off - Hitch System On)
178	62067	1	DPDT, (On)-Off-On Rocker Switch, White 10A, 250V AC (Plow Raise & Lower)
179	61035	4	10-24 x 1/2" Z Machine Screws
N/A	61036	4	10-24 U-Clip
180	61310	1	Plow Lights/Power Switch ON/OFF Label
181	61090	1	Rocker Switch Control Station Label
182	61085	1	2-1/8" x 13-1/8" Push Beam Decal
183	61295	1	Power Hitch Connect/Disconnect Switch Label
184	61303	1	Sequencing Valve & Hydraulic Hose Identification Guide Label
185	61082	1	Moldboard Decal
186	61084	1	Passenger's Side Wing Decal
187	61083	1	Driver's Side Wing Decal
188	61092	1	Serial Number Label (Sequentially Numbered)
189	61180	1	Power Hitch Mounting & Dismounting Instructions Label
190	61086	1	WARNING! Label
191	30037	1	1999-Present Chevrolet/GMC 2500 Series Undercarriage (37" Push Beam)
N/A	61189	1	Hardware Kit #1: (1) - 101, 170, (2) - 68, 85, (4) - 55, 56, 57, 70, (6) - 69
N/A	61190	1	Hardware Kit #2: (1) - 86, 89, 90, 93, 94, (2) - 168, 169, (3) - 86, (4) - 88, 61031, (6) - 52
N/A	60163	1	Hydraulic Adapter Kit: (1) - 81, 37, 141, (2) - 41, 45, (3) - 76, (8) - 43, 44
N/A	60187	1	Hydraulic Hose Kit: (1) - 35, 36, 40, 42, 46-49, 77, 78, 80, 83
N/A	61319	1	Moldboard Cutting Edge Hardware Kit - Kit Includes: (7) - 12, 16, 17
N/A	61320	1	Wing Cutting Edge Hardware Kit - Kit Includes: (1) - 13-15, (3) - 16, 17
N/A	61321	1	Moldboard & Wing Cutting Edges w/Hardware Kits - Includes: (1) - 1,2,5, 61319, (2) - 61321

*Note: The reference numbers listed identify parts shown in the illustration on pages 21-23. These numbers are specific to these illustrations only and do not correspond with other diagrams in the manual. Always review the part number given for proper component identification.*

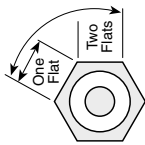

**Torque Table for 37° Adapters**

Port Thread Size	Assembly Torque (foot-pounds)	Original Assembly Torque (F.F.F.T.)
7/16-20	15 ± 1.0	2.5 ± .25
9/16-18	18 ± 2.0	2.5 ± .25

**Torque Table for O.R.B. Adapters**

Port Thread Size	Assembly Torque (foot-pounds)	Original Assembly Torque (F.F.F.T.)
7/16-20	15 ± 1.0	1.5 ± .25
9/16-18	25 ± 2.0	1.5 ± .25

F.F.F.T. = Flats From Finger Tight

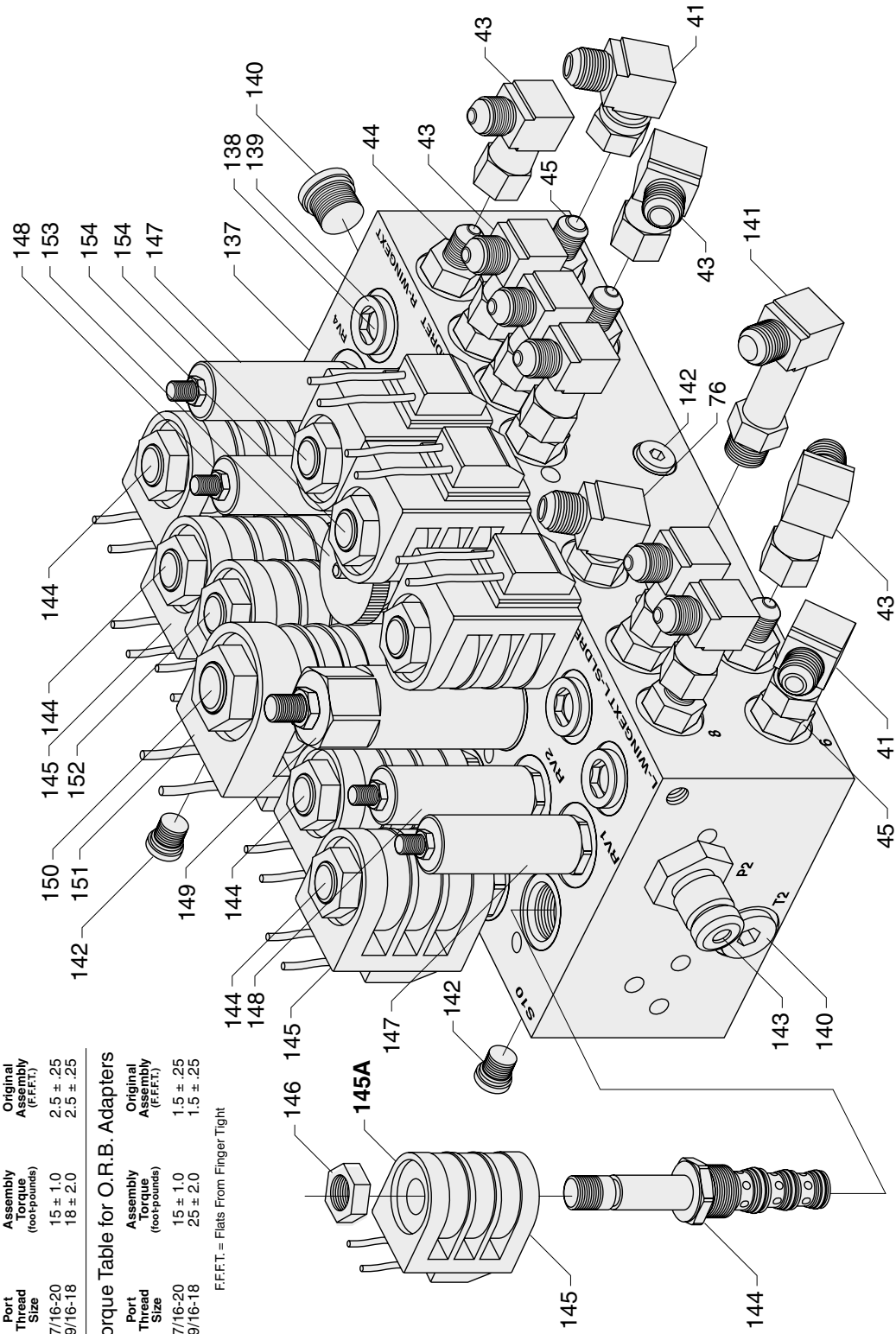



# BLIZZARD<sup>®</sup> POWER PLOW 2001/02

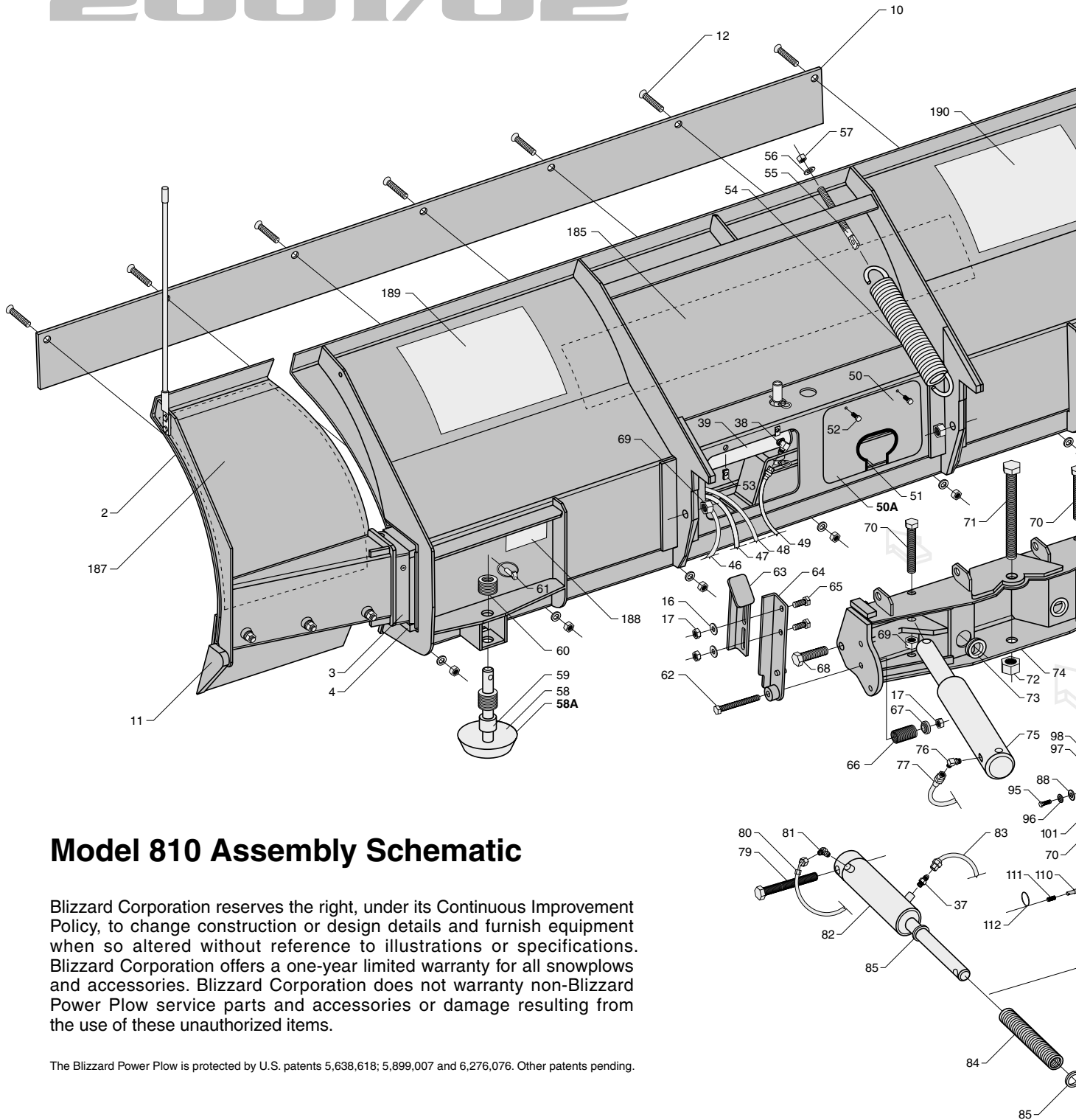

## Model 810 Assembly Schematic

Blizzard Corporation reserves the right, under its Continuous Improvement Policy, to change construction or design details and furnish equipment when so altered without reference to illustrations or specifications. Blizzard Corporation offers a one-year limited warranty for all snowplows and accessories. Blizzard Corporation does not warranty non-Blizzard Power Plow service parts and accessories or damage resulting from the use of these unauthorized items.

The Blizzard Power Plow is protected by U.S. patents 5,638,618; 5,899,007 and 6,276,076. Other patents pending.



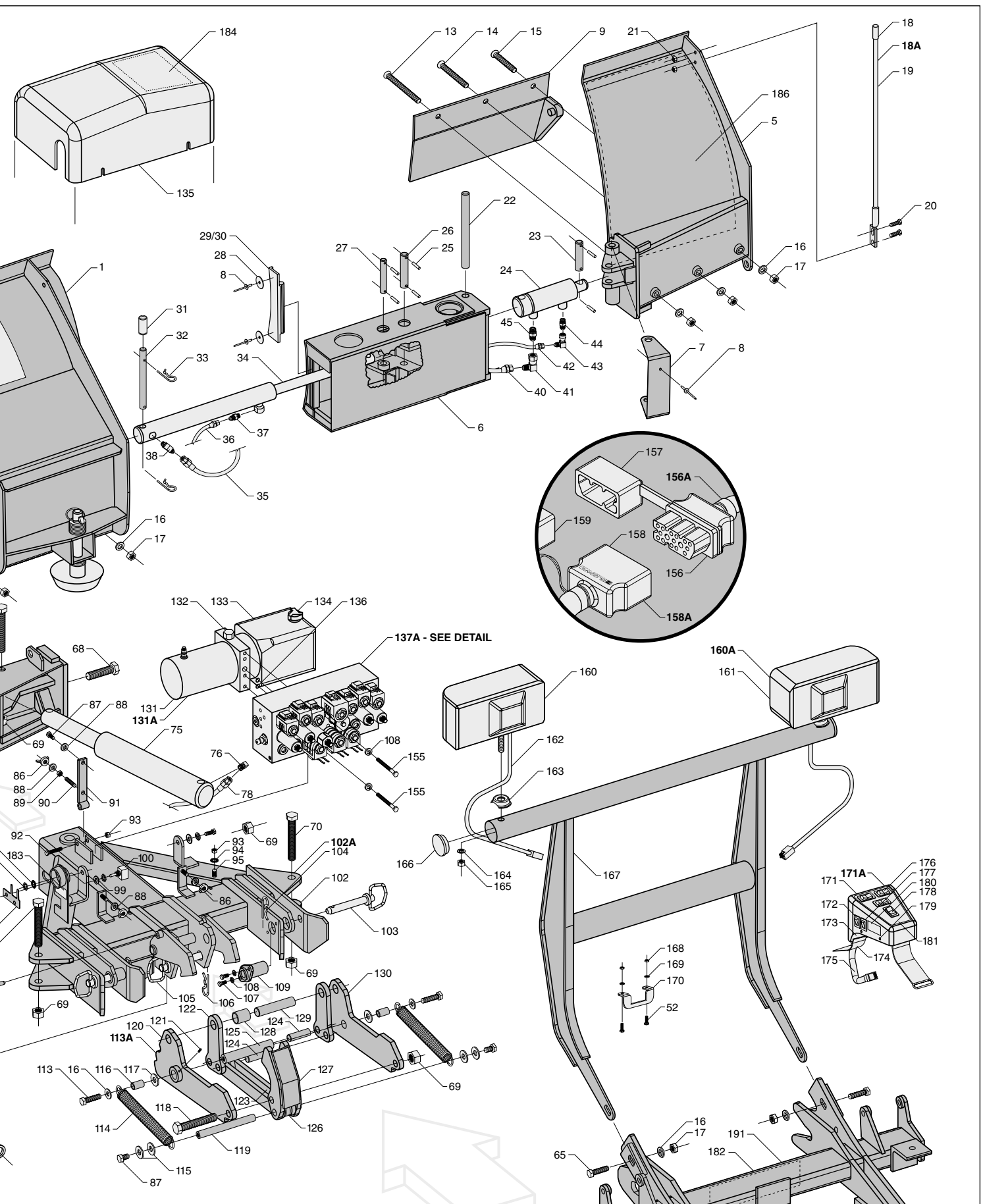

CONNECTS TO M5  
SEE SCHEMATIC ON PAGE 27

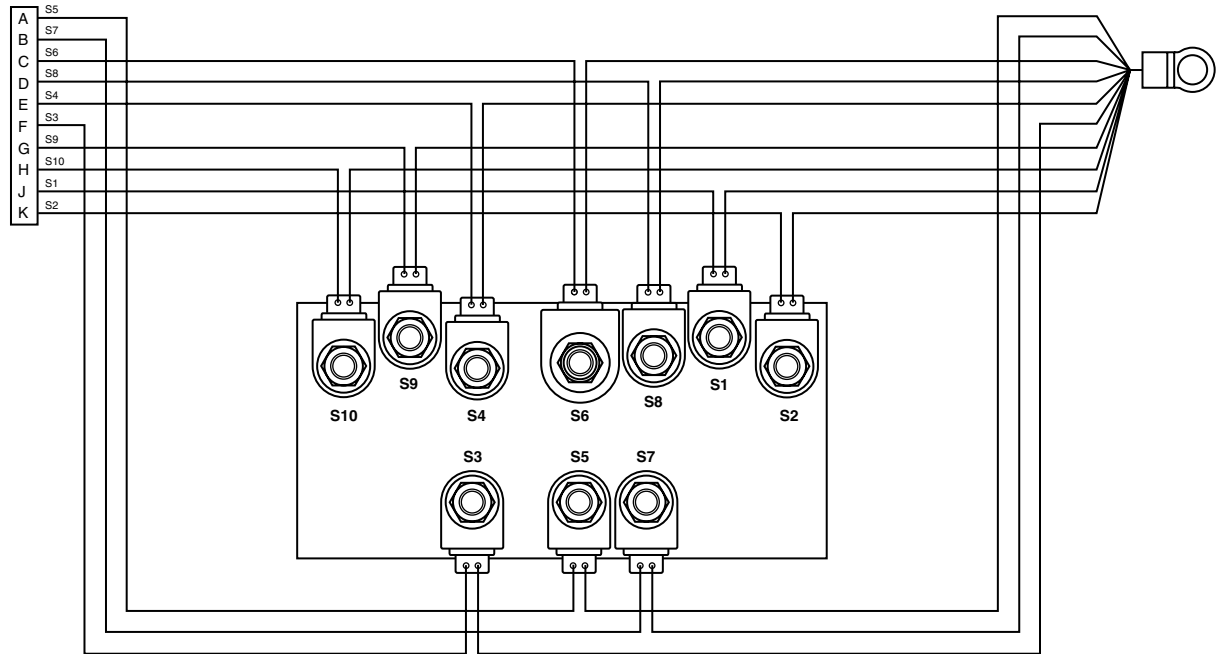

**MODEL 810 COIL HARNESS (P/N 62120) WIRE SCHEMATIC (2001-2002)**

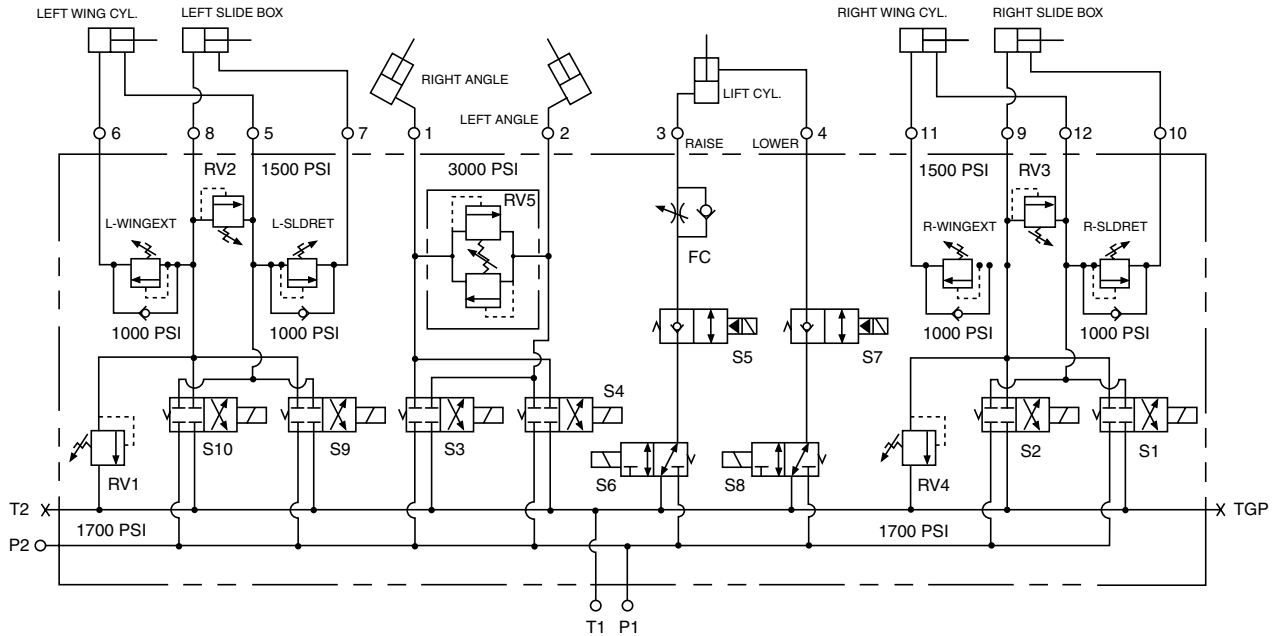

**MODEL 810 HYDRAULIC MANIFOLD SCHEMATIC**

**BLIZZARD HARNESS PLUG (VEHICLE)  
UNIVERSAL 14 + 2 MOLD**

PIN NO.	COLOR	FUNCTION	AWG
1	BLACK	GROUND	4
	BLACK	GROUND	18
2	RED	12 VOLT DC (+)	4
3	BROWN/WHITE	PUMP SOLENOID TO RING	18
	BROWN	PUMP SOLENOID TO MOLEX	18
4	RED/WHITE	RIGHT SLIDE BOX EXTEND	18
5	RED/BLACK	RIGHT SLIDE BOX RETRACT	18
6	BLUE/WHITE	LEFT SLIDE BOX EXTEND	18
7	BLUE/BLACK	LEFT SLIDE BOX RETRACT	18
8	BLUE	LEFT ANGLE	18
9	GREEN	RIGHT ANGLE	18
10	WHITE	LIFT	18
11	ORANGE	FLOAT	18
12	N/A	N/A	N/A
13	N/A	N/A	N/A
14	N/A	N/A	N/A
15	PINK/BLACK	12 (+) VDC FUSED	18
16	N/A	N/A	18

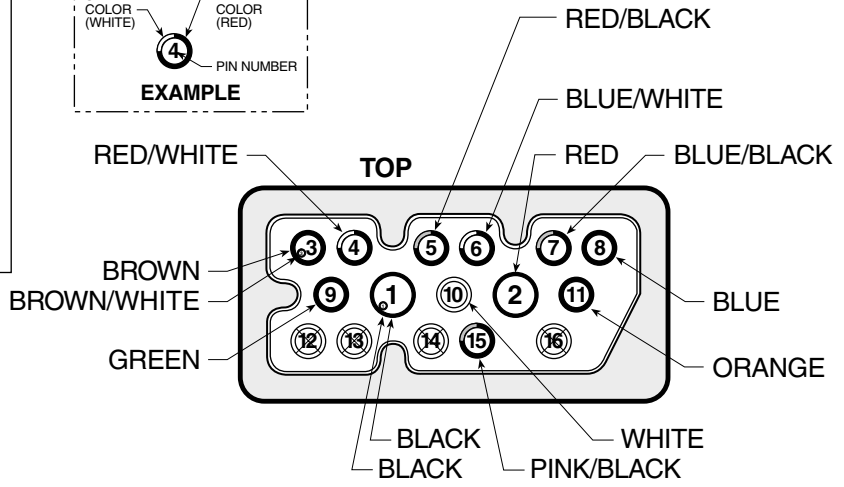
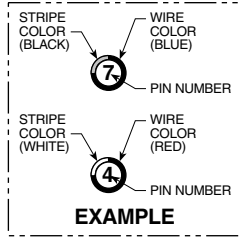
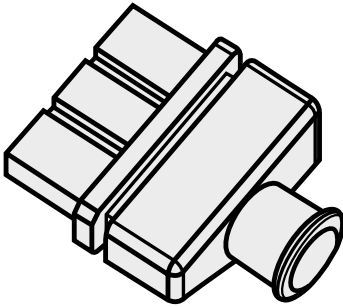

**VEHICLE HARNESS PLUG (2001-2002)**  
END VIEW LOOKING AT FEMALE CONNECTOR  
FEMALE TERMINALS

**BLIZZARD HARNESS PLUG (PLOW)  
UNIVERSAL 14 + 2 MOLD**

PIN NO.	COLOR	FUNCTION	AWG
1	BLACK	GROUND	4
	N/A	N/A	N/A
2	RED	12 VOLT DC (+)	4
3	BROWN	PUMP SOLENOID	18
4	RED/WHITE	RIGHT SLIDE BOX EXTEND	18
5	RED/BLACK	RIGHT SLIDE BOX RETRACT	18
6	BLUE/WHITE	LEFT SLIDE BOX EXTEND	18
7	BLUE/BLACK	LEFT SLIDE BOX RETRACT	18
8	BLUE	LEFT ANGLE	18
9	GREEN	RIGHT ANGLE	18
10	WHITE	LIFT	18
11	ORANGE	FLOAT	18
12	N/A	N/A	N/A
13	N/A	N/A	N/A
14	N/A	N/A	N/A
15	PINK/BLACK	12 (+) VDC FUSED	18
16	N/A	N/A	18

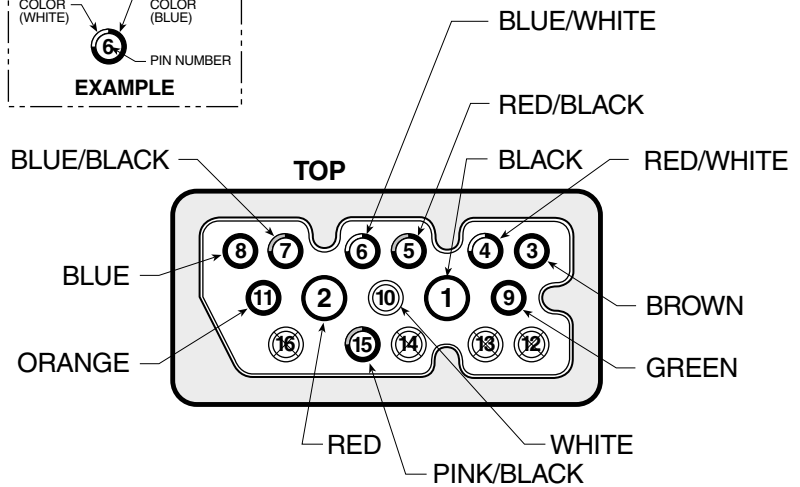
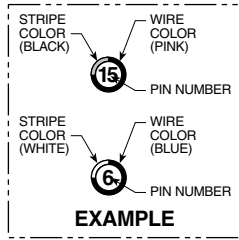
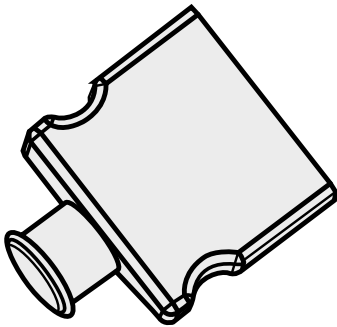

**PLOW HARNESS PLUG (2001-2002)**  
END VIEW LOOKING AT MALE CONNECTOR  
MALE TERMINALS

PIN NO.	COLOR	FUNCTION	AWG
1	BLACK	GROUND	4
2	RED	N/A	N/A
3	RED	12VDC (+)	4
4	RED/WHITE	RIGHT BOX EXTEND	18
5	RED/WHITE	RIGHT BOX RETRACT	18
6	BLUE/WHITE	LEFT BOX EXTEND	18
7	BLUE/WHITE	LEFT BOX RETRACT	18
8	BLUE	RIGHT ANGLE	18
9	GREEN	LEFT ANGLE	18
10	WHITE	LIFT	18
11	ORANGE	LIFT	18
12	N/A	N/A	N/A
13	N/A	N/A	N/A
14	N/A	N/A	N/A
15	ORANGE/BLACK	N/A	N/A
16	N/A	N/A	N/A

**BLIZZARD PLUG (VEHICLE)  
UNIVERSAL 14 + 2 MOLD**

**PACKARD GT 280 ELECTRIC CONNECTOR (PLOW)**

PIN NO.	COLOR	FUNCTION	AWG
A	ORANGE/BLACK	(S5) LOWER/FLOAT	18
B	ORANGE/WHITE	(S7) LEFT/FLOAT	18
C	WHITE	(S6) LIFT	18
D	ORANGE/RED	(S8) HITCH LOWER	18
E	GREEN	(S4) ANGLE RIGHT	18
F	BLUE	(S3) ANGLE LEFT	18
G	BLUE/BLACK	(S9) LEFT SLIDE BOX RET.	18
H	BLUE/WHITE	(S10) LEFT SLIDE BOX EXT.	18
J	RED/BLACK	(S1) RIGHT SLIDE BOX RET.	18
K	RED/WHITE	(S2) RIGHT SLIDE BOX EXT.	18

**OTTO CONNECTOR AMP TERMINALS (18-14 AWG) (TWO 18-14 AWG)**

Terminal	Color	Function
1	(5) PINK/BLACK	
2	(6) PINK/BLACK	
3	(3) WHITE	
4	(1) BROWN	
5	(2) BROWN	
6	(4) ORANGE/RED	
7	(7) AND (8) NOT USED	

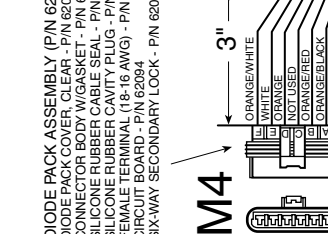
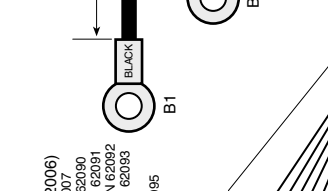
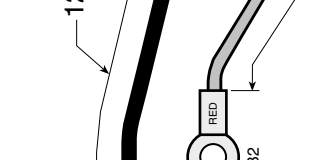
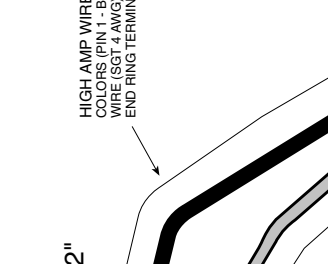

DIODE PACK ASSEMBLY (P/N 62006)  
 DIODE PACK COVER, CLEAR - P/N 62007  
 CONNECTOR BODY W/GASKET - P/N 62090  
 SILICONE RUBBER CABLE SEAL - P/N 62091  
 SILICONE RUBBER CAVITY PLUG - P/N 62092  
 CIRCUIT BOARD - P/N 62093  
 SIX-WAY SECONDARY LOCK - P/N 62095

NOT DRAWN TO SCALE  
 UNLESS OTHERWISE SPECIFIED  
 ALL DIMENSIONS IN INCHES

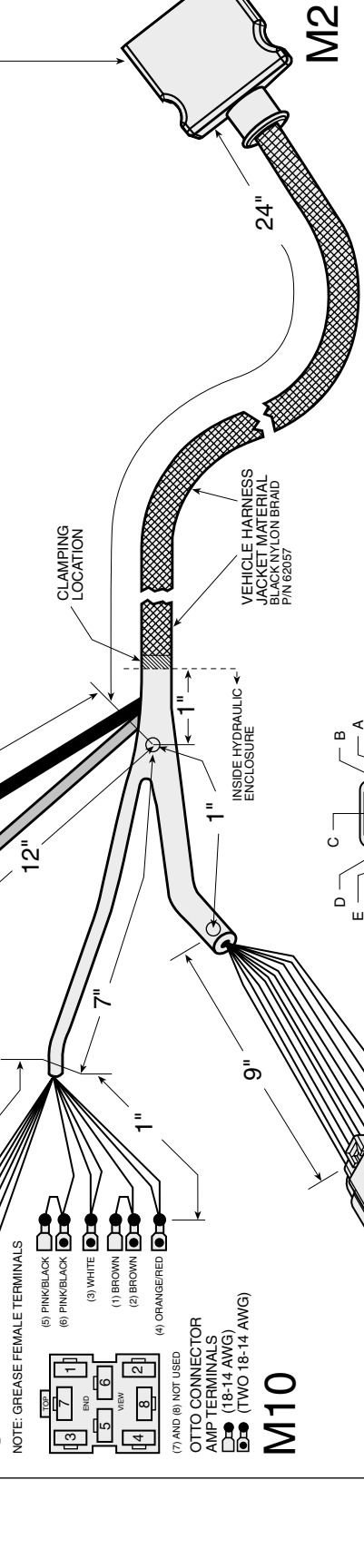

NOT DRAWN TO SCALE  
 UNLESS OTHERWISE SPECIFIED  
 ALL DIMENSIONS IN INCHES

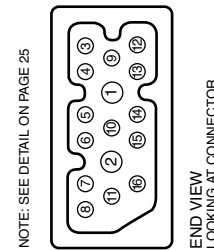

NOTE: SEE DETAIL ON PAGE 25



NOTE: SEE DETAIL ON PAGE 25



NOTE: SEE DETAIL ON PAGE 25

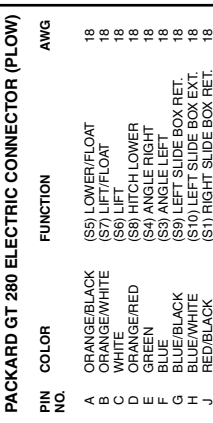

NOTE: SEE DETAIL ON PAGE 25

**PLOW HARNESS (2000-2002)  
WITH MOLDED PLUG  
P/N 62039**

NOT DRAWN TO SCALE  
 UNLESS OTHERWISE SPECIFIED  
 ALL DIMENSIONS IN INCHES

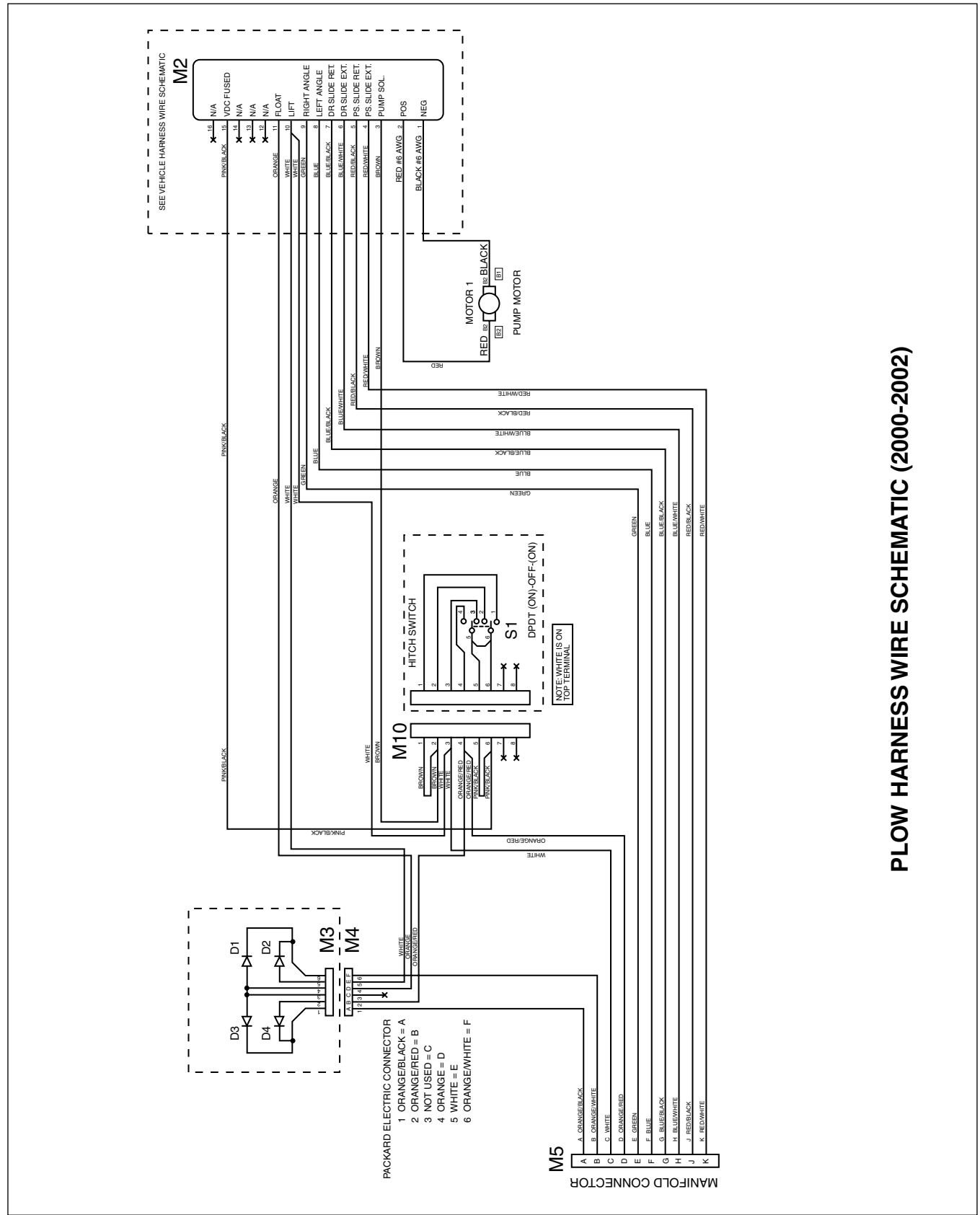

**PLOW HARNESS WIRE SCHEMATIC (2000-2002)**

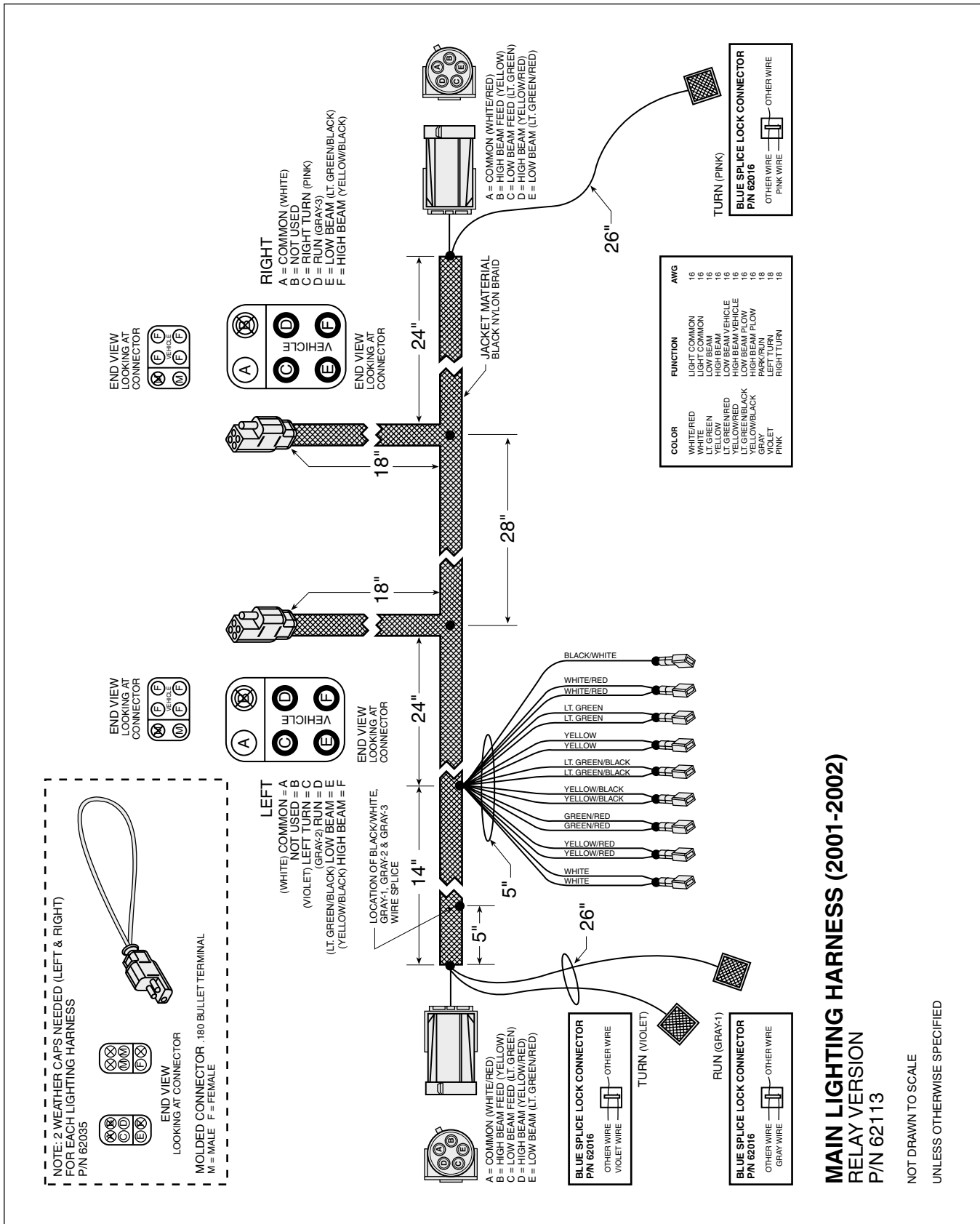

**MAIN LIGHTING HARNESS (2001-2002)**  
**RELAY VERSION**  
**P/N 62113**

NOT DRAWN TO SCALE  
UNLESS OTHERWISE SPECIFIED

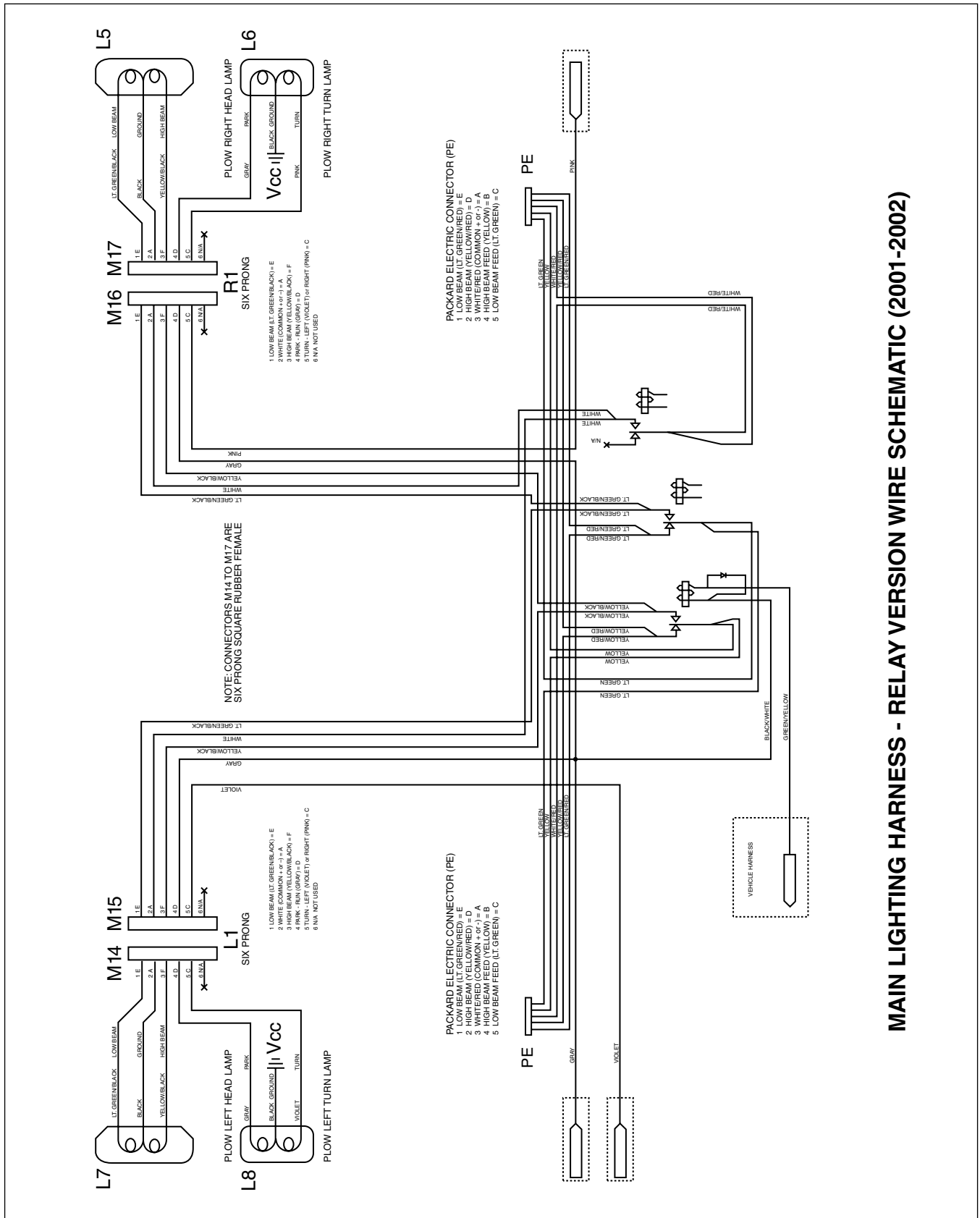

**MAIN LIGHTING HARNESS - RELAY VERSION WIRE SCHEMATIC (2001-2002)**

PIN NO.	COLOR	FUNCTION	AWG
1	BLACK	GROUND	4
2	RED	GROUND	18
3	BROWN/WHITE	PUMP (C)	18
4	BROWN	PUMP SOLENOID TO MOLEX	18
5	RED/WHITE	RIGHT BOX EXTEND	18
6	RED/BLACK	RIGHT BOX RETRACT	18
7	BLUE/BLACK	LEFT BOX EXTEND	18
8	BLUE	LEFT BOX RETRACT	18
9	WHEN	RIGHT ANGLE	18
10	WHEN	RIGHT ANGLE	18
11	ORANGE	FLOAT	18
12	N/A	N/A	N/A
13	N/A	N/A	N/A
14	N/A	N/A	N/A
15	PINK/BLACK	12VDC (H) FUSED	18
16	N/A	N/A	N/A

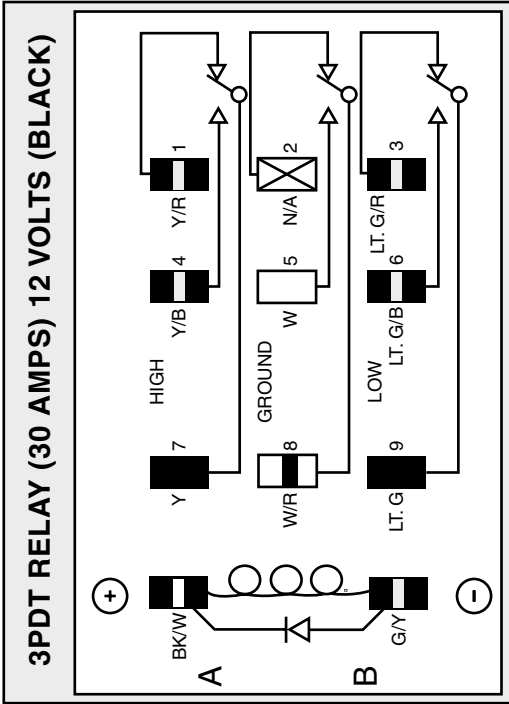

PIN NO.	COLOR	FUNCTION	AWG
1	RED/WHITE	RIGHT SLIDE BOX EXTEND	18
2	RED	RIGHT SLIDE BOX RETRACT	18
3	ORANGE	FLOAT	18
4	RED/WHITE	LEFT SLIDE BOX EXTEND	18
5	RED/BLACK	LEFT SLIDE BOX RETRACT	18
6	BLACK	GROUND	18
7	WHITE	LIFT	18
8	BROWN	JUMP SOLENOID	18
9	BROWN	RIGHT ANGLE	18
10	GREEN	RIGHT ANGLE	18
11	BLUE	RIGHT ANGLE	18
12	BLUE	RIGHT ANGLE	18

AAS-3 HEADLIGHT RELAY  
w/SURGE SUPPRESSION  
VENDOR P/N 90-9055-00-B-TR/SS  
BLIZZARD P/N 62125

NOTE: GREASE FEMALE TERMINALS

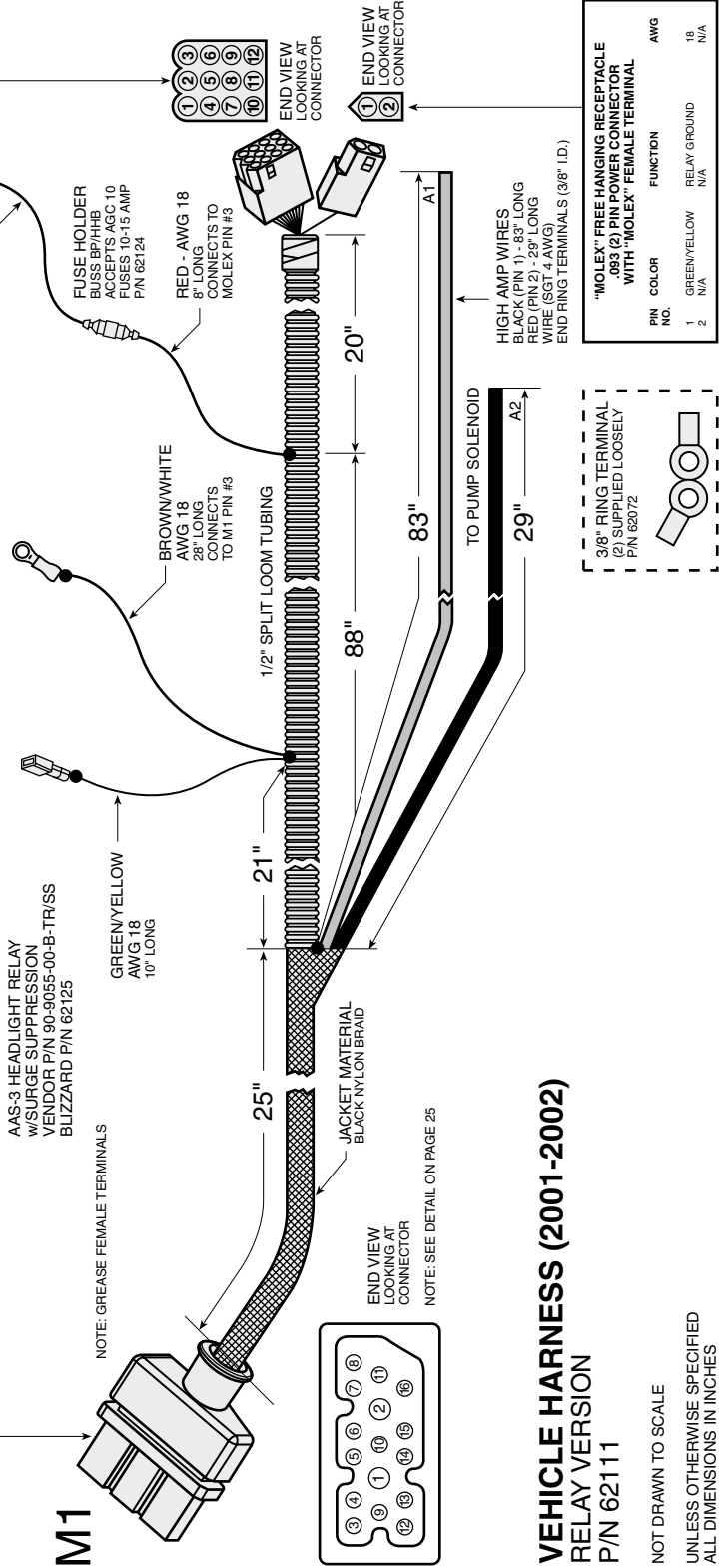

**VEHICLE HARNESS (2001-2002)**  
**RELAY VERSION**  
**P/N 62111**

NOT DRAWN TO SCALE  
UNLESS OTHERWISE SPECIFIED  
ALL DIMENSIONS IN INCHES

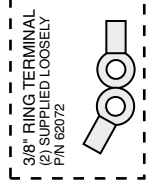

PIN NO.	COLOR	FUNCTION	AWG
1	GREEN/YELLOW	RELAY GROUND	18
2	N/A	N/A	N/A



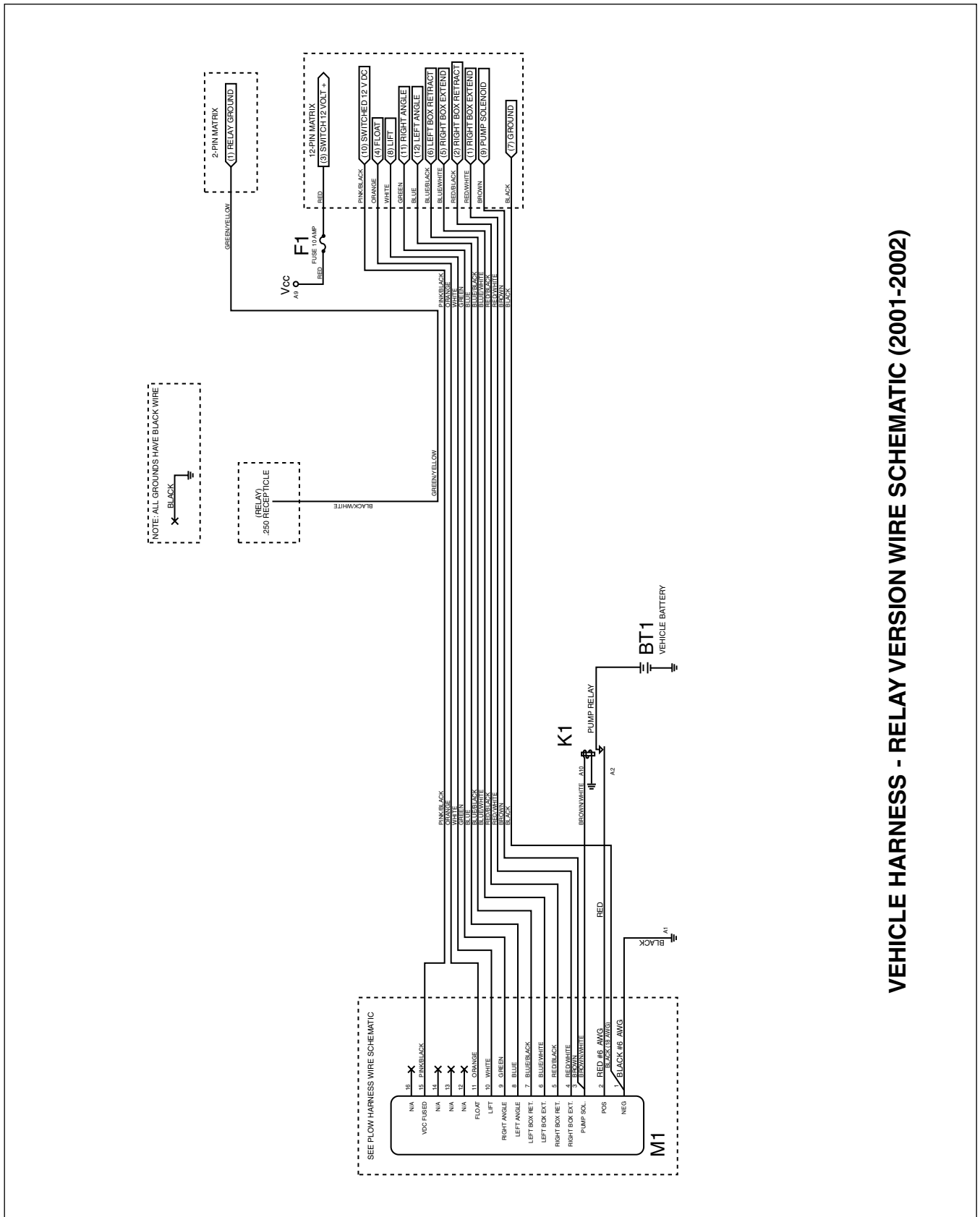

**VEHICLE HARNESS - RELAY VERSION WIRE SCHEMATIC (2001-2002)**

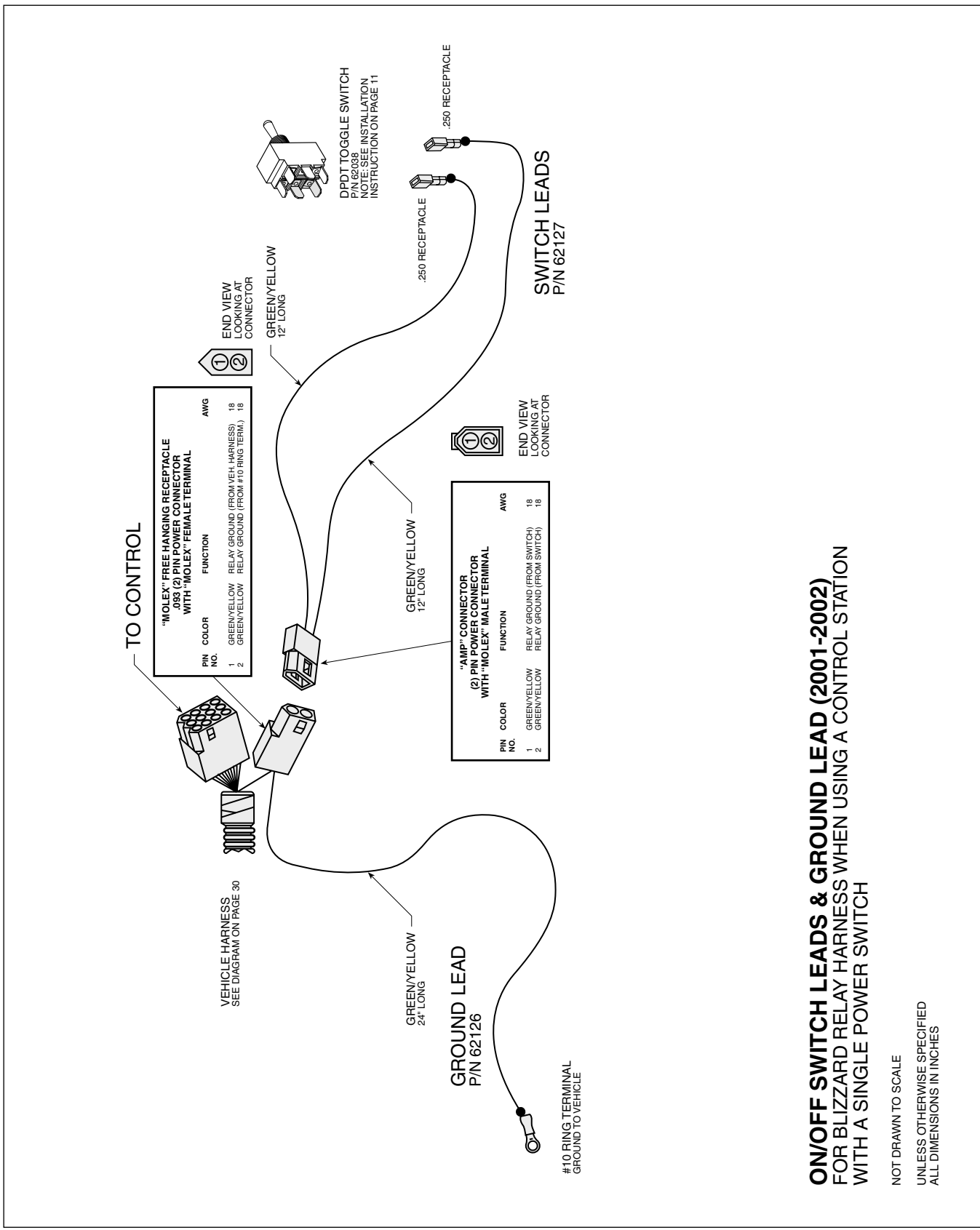

**ON/OFF SWITCH LEADS & GROUND LEAD (2001-2002)**  
 FOR BLIZZARD RELAY HARNESS WHEN USING A CONTROL STATION  
 WITH A SINGLE POWER SWITCH

NOT DRAWN TO SCALE  
 UNLESS OTHERWISE SPECIFIED  
 ALL DIMENSIONS IN INCHES

# TECHNICAL SERVICE BULLETIN

## All Blizzard Snowplows

Issued November 27, 2000

This Technical Service Bulletin (TSB) has been issued for all 2001 Model year Ford Super Duty F-250, F-350, F-450, and F-550 snowplow undercarriage installations. These vehicles (starting in October 2000) contain a front BLOCKER BEAM™ as standard equipment. This beam is designed to prevent a car from sliding beneath the higher riding front truck bumper during a frontal collision.

**WARNING:** Removal of the Blocker Beam™, without the installation of the snowplow undercarriage, may affect air bag deployment in a crash. The vehicle should not be operated without either the snowplow undercarriage or the Blocker Beam™ in place. Should a Blocker Beam™ be removed from the front of a Ford Super Duty truck to accommodate the installation of a snowplow, it should be tagged, packaged and supplied to the customer with the completed vehicle, along with reinstallation instructions (see diagram).

1. To install your Blizzard undercarriage on a Ford F-250, F-350, F-450 or F-550 vehicle, first tag the BLOCKER BEAM™ that is to be removed. This tag will serve as a reminder to re-install the beam should the customer ever remove the snowplow undercarriage. *Note: Tags are being added to all applicable undercarriage kits as a running change. Contact Customer Service toll free at 1-888-680-8600 should you wish to receive tags for undercarriages in inventory.*
2. Loosen the Blocker Beam™ from both SPRING BRACKETS by removing the three fasteners at each end of the Blocker Beam™. Re-attach the fasteners to either end of the Blocker Beam™ for storage.

### BLOCKER BEAM™ TAG

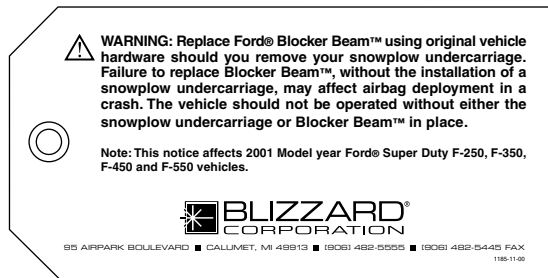

### DRIVER'S SIDE ILLUSTRATION

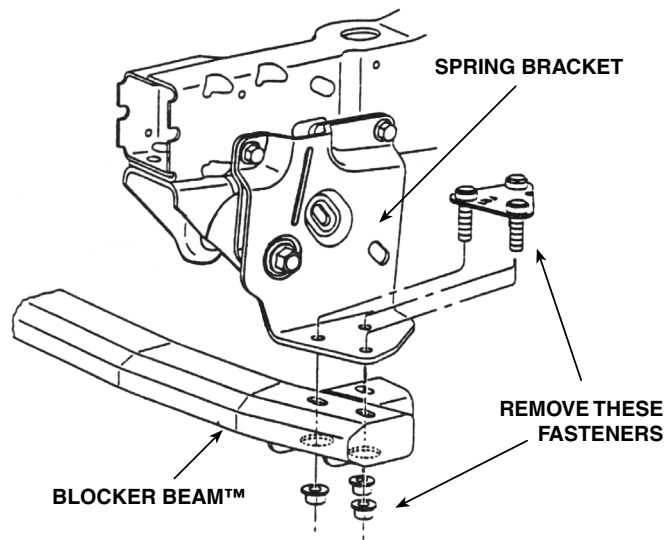

### PUSH BEAM LABEL

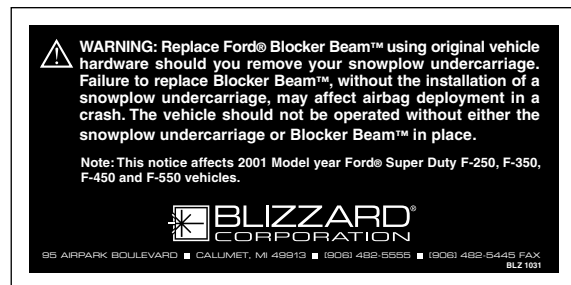

95 AIRPARK BOULEVARD ■ CALUMET, MI 49913 ■ [906] 482-5555 ■ [906] 482-5445 FAX

1183-11-00

# 1987-1991 FORD F-250 & F-350 SERIES UNDERCARRIAGE

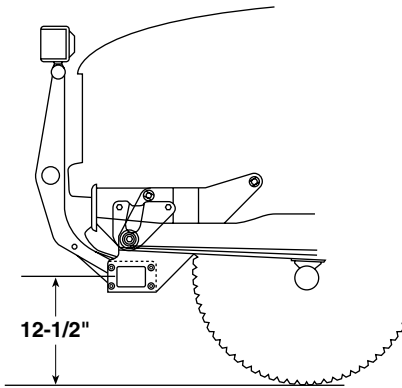

The recommended push beam height for all undercarriage assemblies is 12-1/2" from the center of the push beam to level ground. DO NOT exceed 14" in height for any undercarriage.



**WARNING:** Most new trucks are equipped with driver and passenger's side air bags. DO NOT remove, disable, or reposition any sensory equipment related to the safe operation of the air bags.

ALWAYS follow the vehicle manufacturer's recommendations for installing snowplowing equipment.

Failure to comply with the above warning may result in serious injury or death.



**CAUTION:** If your vehicle is equipped with oversize tires, they may come into contact with the undercarriage hanger plates when turning the vehicle.

The problem may be resolved by setting the steering stops on the vehicle. If this does not correct the problem, the original tires will need to be installed on the vehicle.

1. Begin the undercarriage assembly by removing the front bumper of the vehicle. There are two mounting plates with four M12-1.75 x 45 flanged hex head screws and M12-1.75 nuts to be removed. These are located on the inside of the truck frame rail.
2. Match the holes in each of the HANGER PLATES to those located on the outside of the truck frame rail. Insert one 5/8"-11 x 4" bolt through the rear hole in the hanger plate and truck frame rail. Position one 5/8"-11 top locking nut with 14" welded stock inside of the truck frame rail and fasten. *Note: Loosely attach all nuts until all undercarriage plates are positioned.*
3. Position the hanger plate cut-outs over the spring shackle bolt and leaf spring clamp mounts. Align the front mounting hole on the plate with the hole in the truck frame. Fasten the plate to the vehicle with one 5/8"-11 x 2-3/4" bolt and top lock nut.
4. Complete the hanger plate installation by positioning one 5/8"-11 x 4-1/2" bolt through the middle mounting hole in the plate. Secure the screw with one 5/8" top lock nut.
5. Repeat steps #2 through #4 for the opposite hanger plate. *Note: If your vehicle is equipped with oversize tires, the steering stop may need to be adjusted to prevent the tire from hitting the hanger plate.*
6. Mount the PUSH BEAM to the hanger plates using eight 1/2"-13 x 1-1/2" bolts and 1/2"-13 top lock nuts. *Note: The proper height for the push beam is approximately 12-1/2" from the ground to the center of the push beam.*
7. Once all of the undercarriage plates have been positioned and the proper push beam height is set, proceed to tighten all top lock nuts. Reference the chart on page 4 for maximum bolt torque.
8. Replace the bumper using the existing hardware.
9. Position the LIGHT TOWER into the accepting pockets on the push beam and tighten using two 1/2"-13 x 1-1/4" bolts with washers. Secure each bolt with a 1/2" top locking nut. Mount each PLOW HEADLIGHT to the light tower with the hardware kit provided.

Complete the assembly by plugging the connectors from the lights into the connectors on the vehicle wire harness.

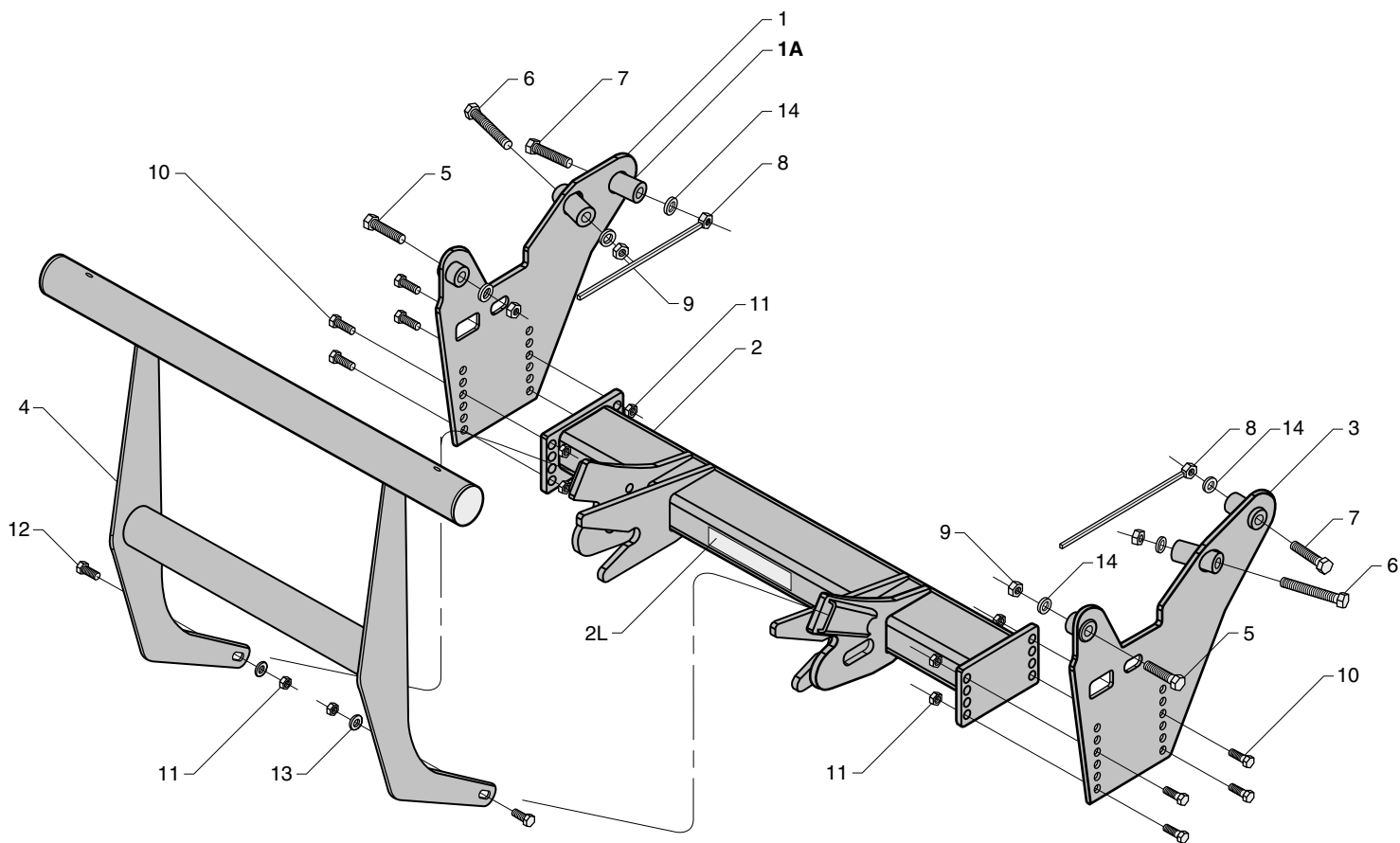

### 1987-1991 FORD F-250 & F-350 SERIES UNDERCARRIAGE PARTS LIST

Ref. No.	Part No.	Qty.	Part Description
<b>1A</b>	<b>31041</b>	<b>1</b>	<b>1987-1991 Ford F-250 &amp; F-350 Series Undercarriage Assembly (Nos. 1-14)</b>
1	31042	1	Passenger's Side Hanger Plate (1987-91 Ford F-250 & F-350)
2	31045	1	41-5/8" Push Beam (1987-91 Ford F-250 & F-350)
2L	61085	1	2-1/8" x 13-1/8" Push Beam Decal
3	31043	1	Driver's Side Hanger Plate (1987-91 Ford F-250 & F-350)
4	39032	1	Light Tower, Round Mounting Tube
5	61061	2	5/8"-11 x 2-3/4" Grade 8 YZ Hex Head Cap Screw
6	61065	2	5/8"-11 x 4-1/2" Grade 8 YZ Hex Head Cap Screw
7	61155	2	5/8"-11 x 4" Grade 8 YZ Hex Head Cap Screw
8	61161	2	5/8"-11 Grade C Z Top Lock Nut with Welded 14" Square Stock
9	61063	4	5/8"-11 Grade C Z Top Lock Nut
10	61055	8	1/2"-13 x 1-1/2" Grade 8 YZ Hex Head Cap Screw
11	61020	10	1/2"-13 Grade C Z Top Lock Nut
12	61057	2	1/2"-13 x 1-1/4" Grade 8 YZ Hex Head Cap Screw
13	61026	2	1/2", 1-1/16" O.D., 17/32" I.D. YZ SAE Mil-Carb High-Strength Washer
14	61064	6	5/8", 1-5/16" O.D., 21/32" I.D., YZ SAE Mil-Carb High-Strength Washer
<b>N/A</b>	<b>61157</b>	<b>1</b>	<b>1987-1991 Ford F-250 &amp; F-350 Series Undercarriage Hardware Kit - Kit Includes: Nos. 5 - 14</b>

Note: The reference numbers listed identify parts shown in the illustration above. These numbers are specific to this illustration only and do not correspond with other diagrams issued. Always review the part number given for proper component identification.

# 1992-1998 FORD F-250 & F-350 SERIES UNDERCARRIAGE

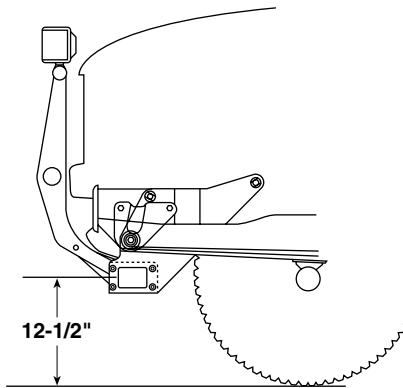

The recommended push beam height for all undercarriage assemblies is 12-1/2" from the center of the push beam to level ground. DO NOT exceed 14" in height for any undercarriage.



**WARNING:** Most new trucks are equipped with driver and passenger's side air bags. DO NOT remove, disable, or reposition any sensory equipment related to the safe operation of the air bags.

ALWAYS follow the vehicle manufacturer's recommendations for installing snowplowing equipment.

Failure to comply with the above warning may result in serious injury or death.



**CAUTION:** If your vehicle is equipped with oversize tires, they may come into contact with the undercarriage hanger plates when turning the vehicle.

The problem may be resolved by setting the steering stops on the vehicle. If this does not correct the problem, the original tires will need to be installed on the vehicle.

1. Begin the assembly by removing the four nuts from the FRONT BUMPER MOUNT. Remove the bumper.
2. Position the DRIVER'S SIDE HANGER PLATE on the outside of the truck frame rail. Attach one 5/8"-11 x 1-3/4" bolt through the front mount on the hanger plate and truck frame rail. Secure the bolt with one 5/8" washer and top lock nut on the inside of the frame rail. *Note: Use the opening at the end of the frame rail to access the nut and washer.*
3. Position one 5/8"-11 x 3-1/4" bolt through the rear mount on the hanger plate and truck frame rail. Secure the bolt with one 5/8" washer and top lock nut on the inside of the frame rail. *Note: Use an original opening cut into the frame rail behind the mounting hole to position the nut and washer.*
4. Position one 5/8"-11 x 2-3/4" bolt through the middle mount on the hanger plate and truck frame rail. Secure the bolt with one 5/8" washer and top lock nut on the inside of the frame rail. *Note: Use an original opening on the inside of the truck frame rail opposite of the mount to position the nut and washer.*
5. Repeat all three procedures above to securely mount the PASSENGER'S SIDE HANGER PLATE.
6. Mount the PUSH BEAM to each hanger plate using four 1/2"-13 x 1-1/2" bolts and top lock nuts. *Note: The proper height for the push beam is approximately 12-1/2" from the ground to the center of the beam.*
7. Once all of the undercarriage plates have been positioned and the proper push beam height is set, proceed to tighten all top lock nuts. Reference the chart on page 4 for maximum bolt torque.
8. Position the LIGHT TOWER into the accepting pockets on the push beam and tighten using two 1/2"-13 x 1-1/4" bolts with washers. Secure each bolt with a 1/2" top lock nut. Mount each PLOW HEADLIGHT to the light tower with the hardware kit provided.

Complete the assembly by plugging the connectors from the lights into the connectors on the vehicle wire harness.

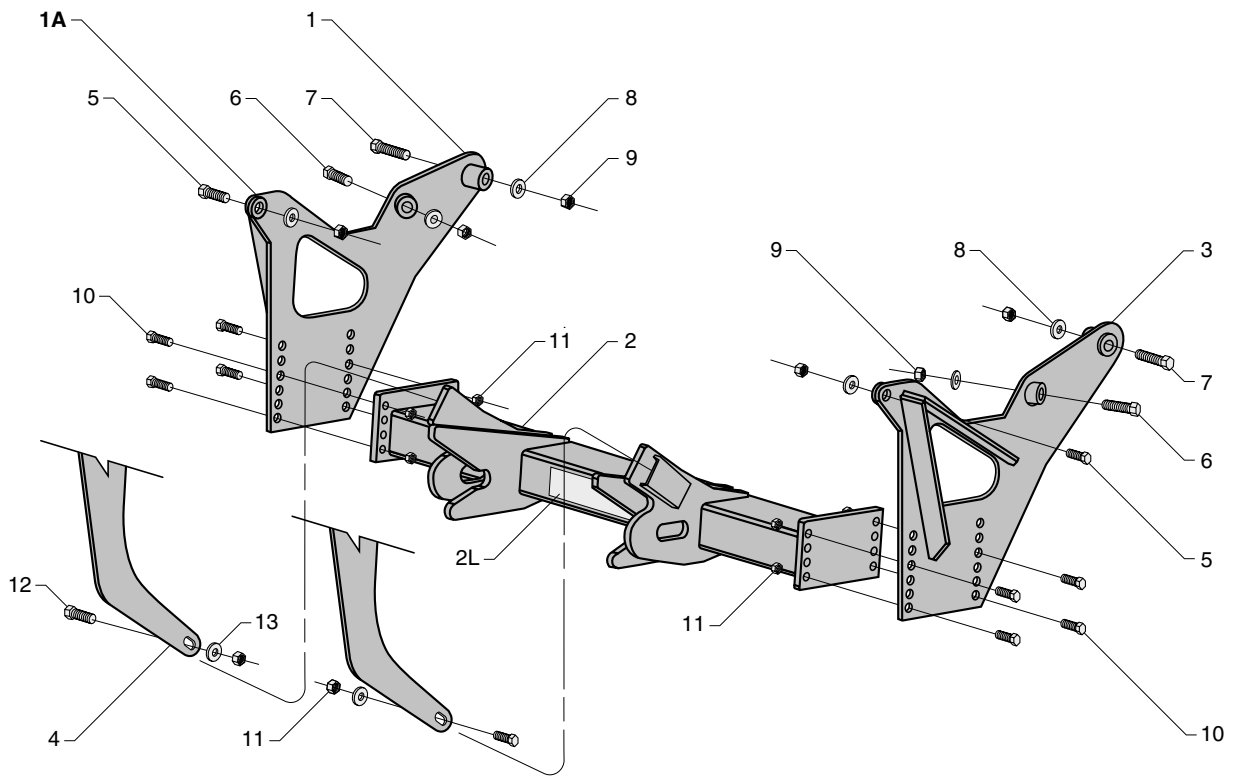

### 1992-1998 FORD F-250 & F-350 SERIES UNDERCARRIAGE PARTS LIST

Ref. No.	Part No.	Qty.	Part Description
<b>1A</b>	<b>31036</b>	<b>1</b>	<b>1992-1998 Ford F-250 &amp; F-350 Series Undercarriage Assembly (Nos. 1-13)</b>
1	31013	1	Passenger's Side Hanger Plate (1992-1998 Ford F-250 & F-350)
2	31019	1	40-5/8" Push Beam (1992-1998 Ford F-250 & F-350)
2L	61085	1	2-1/8" x 13-1/8" Push Beam Decal
3	31011	1	Driver's Side Hanger Plate (1992-1998 Ford F-250 & F-350)
4	39032	1	Light Tower, Round Mounting Tube
5	61060	2	5/8"-11 x 1-3/4" Grade 8 YZ Hex Cap Screw
6	61061	2	5/8"-11 x 2-3/4" Grade 8 YZ Hex Cap Screw
7	61062	2	5/8"-11 x 3-1/4" Grade 8 YZ Hex Cap Screw
8	61064	6	5/8", 1-5/16" O.D., 21/32" I.D., YZ SAE Mil-Carb High-Strength Washer
9	61063	6	5/8"-11 Grade C Z Top Lock Nut
10	61055	8	1/2"-13 x 1-1/2" Grade 8 YZ Hex Head Cap Screw
11	61020	10	1/2"-13 Grade C Z Top Lock Nut
12	61057	2	1/2"-13 x 1-1/4" Grade 8 YZ Hex Head Cap Screw
13	61026	2	1/2", 1-1/16" O.D., 17/32" I.D. YZ SAE Mil-Carb High-Strength Washer
<b>N/A</b>	<b>61080</b>	<b>1</b>	<b>1992-1998 Ford F-250 &amp; F-350 Series Undercarriage Hardware Kit - Kit Includes: Nos. 5 - 13</b>

Note: The reference numbers listed identify parts shown in the illustration above. These numbers are specific to this illustration only and do not correspond with other diagrams in the manual. Always review the part number given for proper component identification.

# 1999-2002 FORD F-250 & F-350 SERIES UNDERCARRIAGE

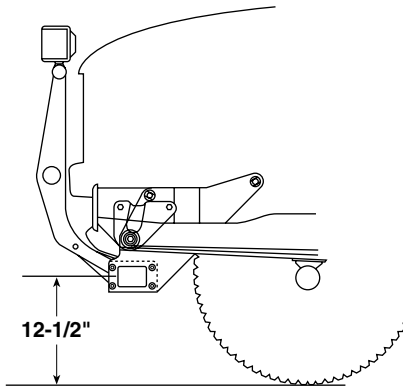

The recommended push beam height for all undercarriage assemblies is 12-1/2" from the center of the push beam to level ground. DO NOT exceed 14" in height for any undercarriage.



**WARNING:** Most new trucks are equipped with driver and passenger's side air bags. DO NOT remove, disable, or reposition any sensory equipment related to the safe operation of the air bags.

ALWAYS follow the vehicle manufacturer's recommendations for installing snowplowing equipment.

Failure to comply with the above warning may result in serious injury or death.



**CAUTION:** If your vehicle is equipped with oversize tires, they may come into contact with the undercarriage hanger plates when turning the vehicle.

The problem may be resolved by setting the steering stops on the vehicle. If this does not correct the problem, the original tires will need to be installed on the vehicle.



If your vehicle is equipped with a Blocker Beam™ review the Technical Service Bulletin on page 33.

1. Begin the undercarriage assembly by removing the front bumper of the vehicle. There are four 1/2"-13 x 1-3/4" acorn head bolts with 1/2" washers, two nut plates and two bumper shim plates to remove. *Note: The bumper shim plate prohibits the proper mounting bolts from being installed. Either discard the plate or increase the size of the holes located on the front.*

*Note: If your vehicle is equipped with a Blocker Beam™, review the Technical Service Bulletin on page 33.*

2. Attach each HANGER PLATE (2) to the truck frame rails using two 1/2"-13 x 1-1/4" bolts and washers. Secure all bolts using a 1/2"-13 top lock nut. *Note: Loosely attach all nuts until all undercarriage plates are positioned.*
3. Rest both ZEE BRACKETS on the truck frame rail and fasten two 1/2"-13 x 1-1/2" bolts with washers to the hanger plate. Loosely tighten 1/2"-13 top lock nuts to all bolts.
4. Install one 9/16"-12 x 1-1/2" bolt with a 9/16" washer inside of the truck frame bumper bracket to the side zee bracket ear. Loosely thread a 9/16"-12 top lock nut to each bolt.
5. Mount the PUSH BEAM to the hanger plate using two 1/2"-13 x 1-1/2" bolts and top lock nuts. *Note: The proper height for the push beam is approximately 12-1/2" from the ground to the center of the beam.*
6. Remove the M12-1.75 x 35 (10.9 Gr.) rear spring shackle bolt with tabbed nut on the outside of the frame rail. Position each HANGER SUPPORT PLATE on the outside of the hanger plate and truck frame rail. *Note: If your vehicle does not have a Blocker Beam™ installed on it, you will need to add three 1/2" washers between the plate and the truck frame rail. The washers are not needed if your vehicle came with the Blocker Beam™ installed.* Reattach an M12-1.75 x 60 (10.9 Gr.) bolt and the original tabbed nut. Bolt the support plate into the truck frame rail using two 1/2"-13 x 2" bolts. Secure the support plate to the hanger plate and push beam using two 1/2"-13 x 2-1/4" bolts and lock nuts.
7. Once all of the undercarriage plates have been positioned and the proper push beam height is set, proceed to tighten all top lock nuts. Reference the chart on page 4 for maximum bolt torque.
8. Replace the bumper using the existing hardware.
9. Position the LIGHT TOWER into the accepting pockets on the push beam and tighten using two 1/2"-13 x 1-1/4" bolts with washers. Secure each bolt with a 1/2" top locking nut. Mount each PLOW HEADLIGHT to the light tower with the hardware kit provided.

Complete the assembly by plugging the connectors from the lights into the connectors on the vehicle wire harness.



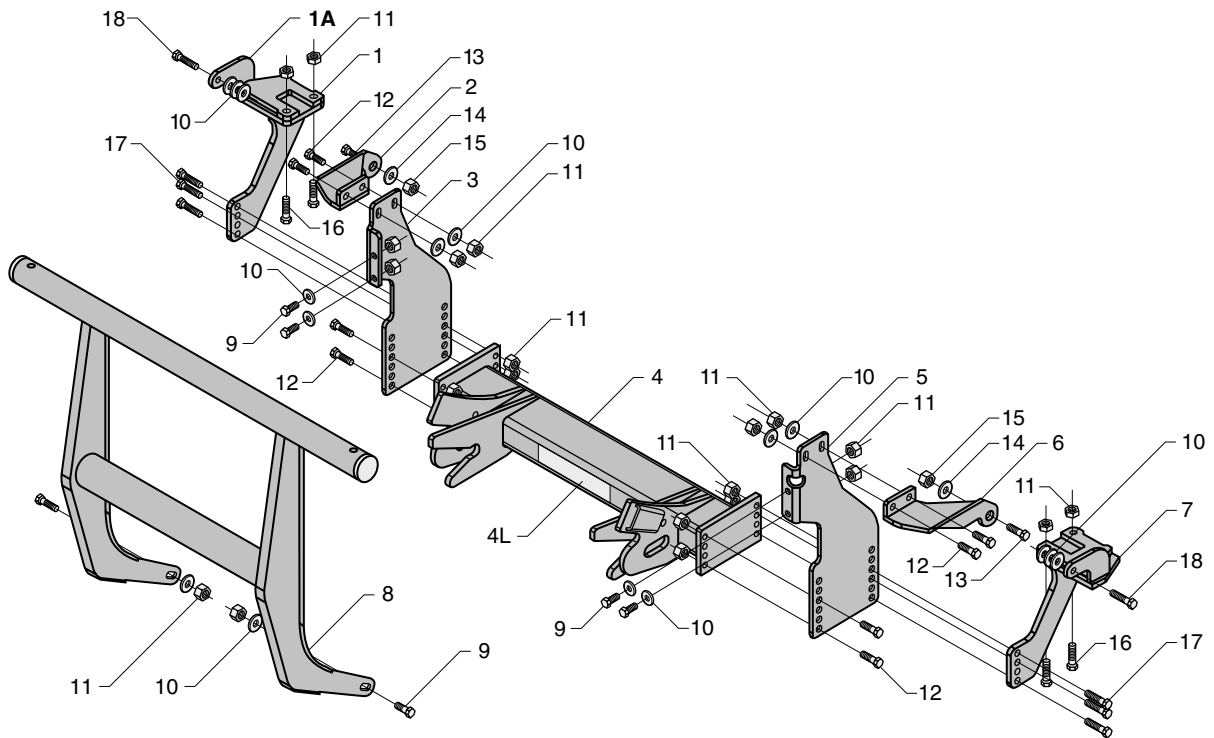

### 1999-2002 FORD F-250 & F-350 SERIES UNDERCARRIAGE PARTS LIST

Ref. No.	Part No.	Qty.	Part Description
<b>1A</b>	<b>31090</b>	<b>1</b>	<b>1999-2002 Ford F-250 &amp; F-350 Series Undercarriage Assembly (Nos. 1 - 18)</b>
1	31089	1	Passenger's Side Push Beam Support Arm (1999-2002 Ford F-250 & F-350)
2	31086	1	Passenger's Side Zee Bracket (1999-2002 Ford F-250 & F-350)
3	31091	1	Passenger's Side Hanger Plate (1999-2002 Ford F-250 & F-350)
4	31021	1	32-1/2" Push Beam (1999-2002 Ford F-250 & F-350)
4L	61085	1	2-1/8" x 13-1/8" Push Beam Decal
5	31092	1	Driver's Side Hanger Plate (1999-2002 Ford F-250 & F-350)
6	31034	1	Driver's Side Zee Bracket (1999-2002 Ford F-250 & F-350)
7	31088	1	Driver's Side Push Beam Support Arm (1999-2002 Ford F-250 & F-350)
8	39032	1	Light Tower, Round Mounting Tube
9	61057	6	1/2"-13 x 1-1/4" Grade 8 YZ Hex Head Cap Screw
10	61026	16	1/2", 1-1/16" O.D., 17/32" I.D. YZ SAE Mil-Carb High-Strength Washer
11	61020	24	1/2"-13 Grade C Z Top Lock Nut
12	61055	8	1/2"-13 x 1-1/2" Grade 8 YZ Hex Head Cap Screw
13	61056	2	9/16"-12 x 1-1/2" Grade 8 YZ Hex Cap Screw
14	61059	2	9/16", 1-3/16" O.D., 19/32" I.D. YZ SAE Mil-Carb High-Strength Washer
15	61058	2	9/16"-12 Grade C Z Top Lock Nut
16	61018	4	1/2"-13 x 2" Grade 8 YZ Hex Head Cap Screw
17	61054	6	1/2"-13 x 2-1/4" Grade 8 YZ Hex Head Cap Screw
18	61311	2	M12-1.75 x 60 Grade 10.9 Z Hex Head Cap Screw
<b>N/A</b>	<b>61079</b>	<b>1</b>	<b>1999-2002 Ford F-250 &amp; F-350 Series Undercarriage Hardware Kit - Kit Includes: Nos. 9 -18</b>

Note: The reference numbers listed identify parts shown in the illustration above. These numbers are specific to this illustration only and do not correspond with other diagrams in the manual. Always review the part number given for proper component identification.

# 1999-2002 FORD F-450 & F-550 SERIES UNDERCARRIAGE

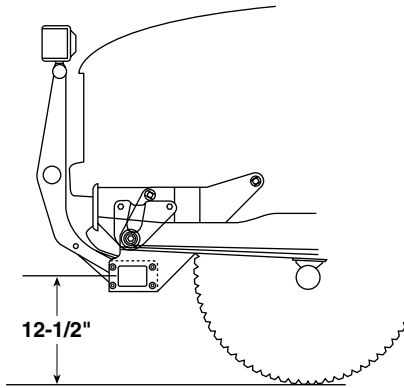

The recommended push beam height for all undercarriage assemblies is 12-1/2" from the center of the push beam to level ground. DO NOT exceed 14" in height for any undercarriage.



**WARNING:** Most new trucks are equipped with driver and passenger's side air bags. DO NOT remove, disable, or reposition any sensory equipment related to the safe operation of the air bags.

ALWAYS follow the vehicle manufacturer's recommendations for installing snowplowing equipment.

Failure to comply with the above warning may result in serious injury or death.



**CAUTION:** If your vehicle is equipped with oversize tires, they may come into contact with the undercarriage hanger plates when turning the vehicle.

The problem may be resolved by setting the steering stops on the vehicle. If this does not correct the problem, the original tires will need to be installed on the vehicle.



If your vehicle is equipped with a Blocker Beam™ review the Technical Service Bulletin on page 33.

*Note: If your vehicle is equipped with a Blocker Beam™, review the Technical Service Bulletin on page 33.*

1. Begin the assembly by positioning the DRIVER'S SIDE HANGER PLATE on the outside of the truck frame rail and in front of the shock mount. In this position, the plate will locate above the front spring shackle. Attach one 5/8"-11 x 3" bolt and washer through the top rear mount. Secure the bolt with one 5/8" top lock nut. *Note: There are two original openings cut into the frame rail. Use the rear opening to position a top lock nut for the 3" bolt inserted in the front opening.*
2. Position one 5/8"-11 x 4-1/2" bolt and washer through the top front mount. Use a 1" box end wrench to position one 5/8" top lock nut through the truck frame rail opening at the tow hook and securely fasten.
3. Repeat both of the procedures above for the PASSENGER'S SIDE HANGER PLATE.
4. Mount the PUSH BEAM to each hanger plate using four 1/2"-13 x 2" bolts and top lock nuts. *Note: The proper height for the push beam is approximately 12-1/2" from the ground to the center of the beam.*
5. Once all of the undercarriage plates have been positioned and the proper push beam height is set, proceed to tighten all top locking nuts. Reference the chart on page 4 for maximum bolt torque.
6. Position the LIGHT TOWER into the accepting pockets on the push beam and tighten using two 1/2"-13 x 1-1/4" bolts with washers. Secure each bolt with a 1/2" top locking nut. Mount each PLOW HEADLIGHT to the light tower with the hardware kit provided.

Complete the assembly by plugging the connectors from the lights into the connectors on the vehicle wire harness.

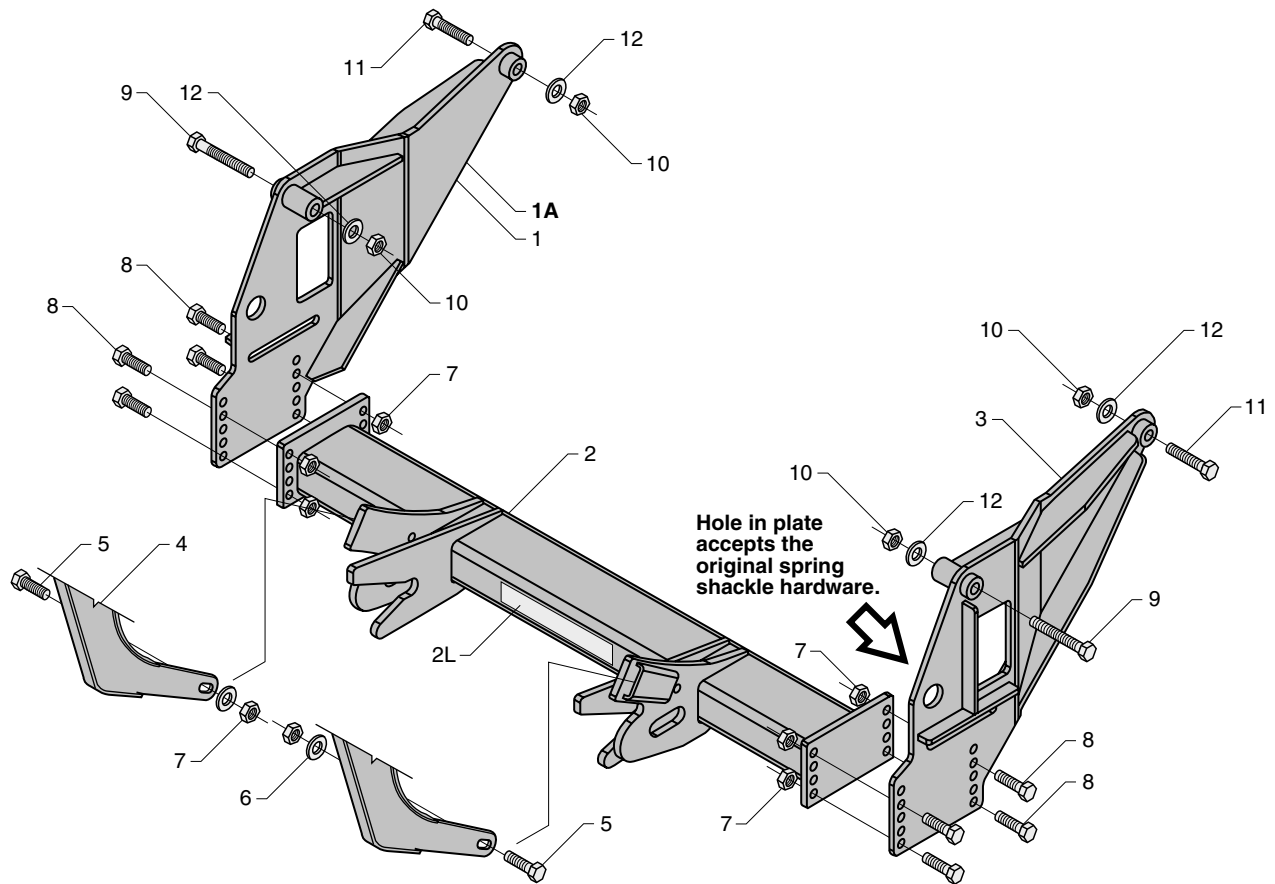

### 1999-2002 FORD F-450 & F-550 SERIES UNDERCARRIAGE PARTS LIST

Ref. No.	Part No.	Qty.	Part Description
<b>1A</b>	<b>31037</b>	<b>1</b>	<b>1999-2002 Ford F-450 &amp; F-550 Series Undercarriage Assembly (Nos. 1 - 12)</b>
1	31027	1	Passenger's Side Hanger Plate (1999-2002 Ford F-450 & F-550)
2	31032	1	46" Push Beam (1999-2002 Ford F-450 & F-550)
2L	61085	1	2-1/8" x 13-1/8" Push Beam Decal
3	31026	1	Driver's Side Hanger Plate (1999-2002 Ford F-450 & F-550)
4	39032	1	Light Tower, Round Mounting Tube
5	61057	2	1/2"-13 x 1-1/4" Grade 8 YZ Hex Head Cap Screw
6	61026	2	1/2", 1-1/16" O.D., 17/32" I.D. YZ SAE Mil-Carb High-Strength Washer
7	61020	10	1/2"-13 Grade C Z Top Lock Nut
8	61018	8	1/2"-13 x 2" Grade 8 YZ Hex Head Cap Screw
9	61065	2	5/8"-11 x 4-1/2" Grade 8 YZ Hex Cap Screw
10	61063	4	5/8"-11 Grade C Z Top Lock Nut
11	61066	2	5/8"-11 x 3" Grade 8 YZ Hex Cap Screw
12	61064	4	5/8", 1-5/16" O.D., 21/32" I.D., YZ SAE Mil-Carb High-Strength Washer
<b>N/A</b>	<b>61081</b>	<b>1</b>	<b>1999-2002 Ford F-450 &amp; F-550 Series Undercarriage Hardware Kit - Kit Includes: Nos. 5 -12</b>

Note: The reference numbers listed identify parts shown in the illustration above. These numbers are specific to this illustration only and do not correspond with other diagrams in the manual. Always review the part number given for proper component identification.

# 1982-1987 CHEVROLET/GMC C20/C30 & K20/K30 UNDERCARRIAGE

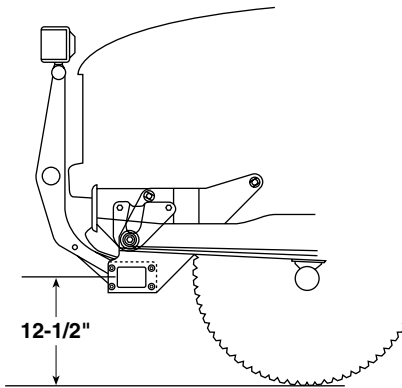

The recommended push beam height for all undercarriage assemblies is 12-1/2" from the center of the push beam to level ground. DO NOT exceed 14" in height for any undercarriage.



**WARNING:** Most new trucks are equipped with driver and passenger's side air bags. DO NOT remove, disable, or reposition any sensory equipment related to the safe operation of the air bags.

ALWAYS follow the vehicle manufacturer's recommendations for installing snowplowing equipment.

Failure to comply with the above warning may result in serious injury or death.



**CAUTION:** If your vehicle is equipped with oversize tires, they may come into contact with the undercarriage hanger plates when turning the vehicle.

The problem may be resolved by setting the steering stops on the vehicle. If this does not correct the problem, the original tires will need to be installed on the vehicle.

1. Begin the assembly by removing (if applicable) both 1/2"-13 x 2-1/2" bolts with washers and nuts that attach each tow hook to the truck frame rail. Discard all hardware.
2. Next, remove both 7/16"-14 x 1-1/4" bolts and 3/8" lock washers from the rear mount of each bumper support bracket. *Note: Each hole contains a welded nut on the inside of the truck frame rail eliminating the need for new hardware; however, top lock nuts and washers are provided should the welded nuts be corroded or the threads have been damaged.*
3. Position the DRIVER'S SIDE HANGER PLATE on the inside of the truck frame rail and in front of the sway bar crossmember. *Note: The bushings should rest against the frame and the gussets should face the vehicle's tires.* Align the top and bottom rear bushings with the holes for the bumper support bracket. Secure the plate with two 7/16"-14 x 4-1/2" bolts. If needed, replace the welded nuts on the frame with the 7/16" washers and top lock nuts provided.
4. Align the three front bushings on the hanger plate with the holes for the tow hook mounts located in the truck frame rail. Position one 1/2"-13 x 4-1/2" bolt through each bushing and secure with one 1/2" washer and top lock nut.
5. Repeat steps #3 & #4 to install the PASSENGER'S SIDE HANGER PLATE.
6. Mount the PUSH BEAM to each hanger plate using two 1/2"-13 x 1-1/2" bolts and top lock nuts at the front of the beam. The rear push beam mount holes receive 1/2"-13 x 2" bolts. *Note: The proper height for the push beam is approximately 12-1/2" from the ground to the center of the push beam.*
7. Next, align the top hole on the PASSENGER'S SIDE HANGER PLATE SUPPORT ARM with the top hole on the *inside* of the push beam. Fit the support arm against the truck frame rail and mark the hole locations on the frame. Drill two holes into the truck frame to properly mount the support plate. Attach the support plate to the vehicle using two 1/2"-13 x 1-1/2" bolts with washers and top lock nuts. Complete the same installation for the DRIVER'S SIDE HANGER PLATE SUPPORT ARM. The support arm mounts to the *outside* of the hanger plate. Align the top hole on the support to the top hole on the hanger plate.
8. Once all of the undercarriage plates have been positioned and the proper push beam height is set, proceed to tighten all top lock nuts. Reference the chart on page 4 for maximum bolt torque.
9. Position the LIGHT TOWER into the accepting pockets on the push beam and tighten using two 1/2"-13 x 1-1/4" Grade 8 YZ hex cap screws with washers. Secure each bolt with a 1/2" top locking nut. Mount each PLOW HEADLIGHT to the light tower with the hardware kit provided.

Complete the assembly by plugging the connectors from the lights into the connectors on the vehicle wire harness.

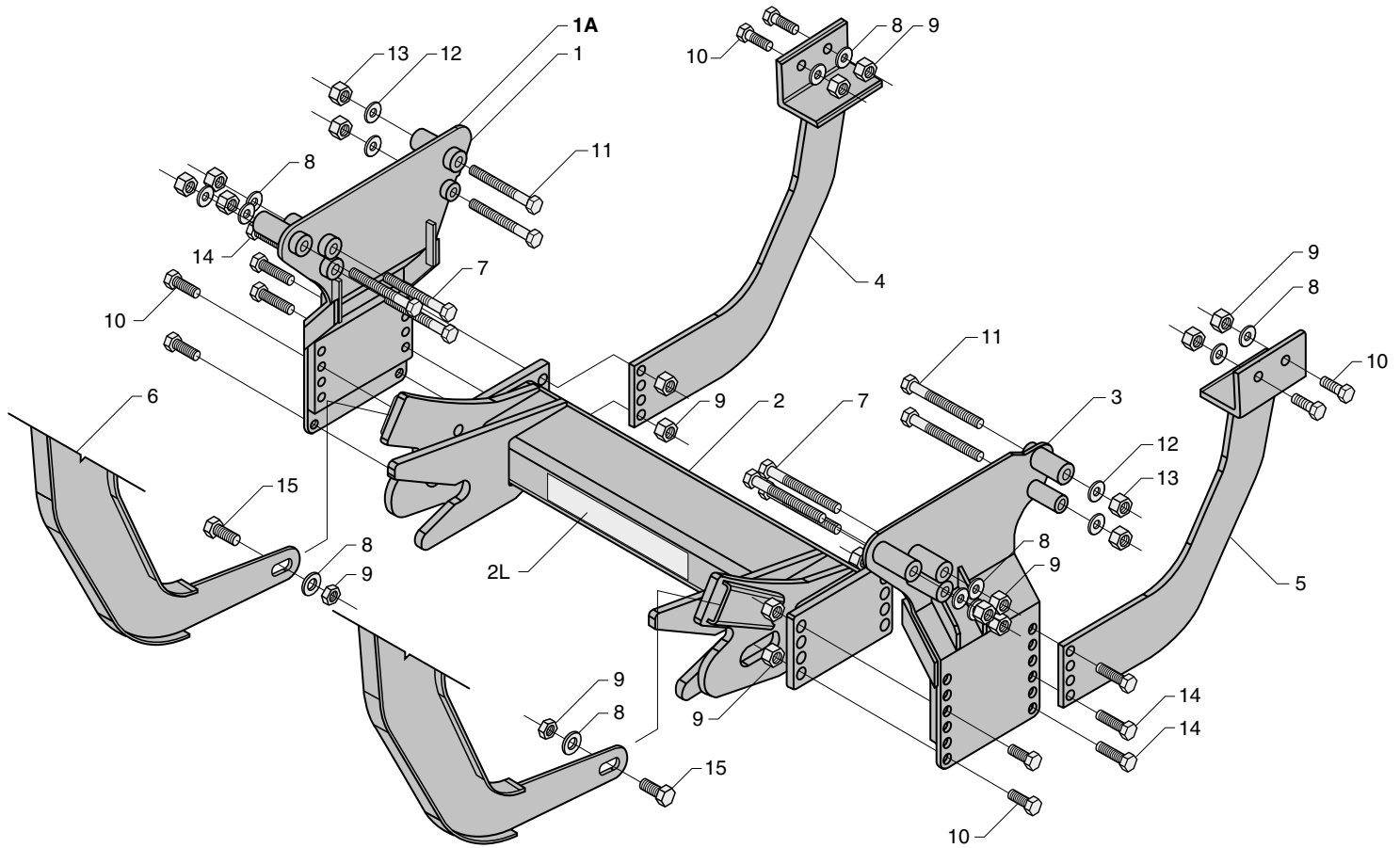

### 1982-1987 CHEVROLET/GMC C20/C30 & K20/K30 UNDERCARRIAGE PARTS LIST

Ref. No.	Part No.	Qty.	Part Description
<b>1A</b>	<b>30055</b>	<b>1</b>	<b>1982-1987 Chevrolet/GMC C20/C30 &amp; K20/K30 Undercarriage Assembly (Nos. 1 - 15)</b>
1	30048	1	Passenger's Side Hanger Plate (1982-87 Chevrolet/GMC C20/C30 & K20/K30)
2	30053	1	26-1/4" Push Beam (1982-87 Chev/GMC C20/C30 & K20/K30 & 1979-93 Dodge 2500 & 3500)
2L	61085	1	2-1/8" x 13-1/8" Push Beam Decal
3	30046	1	Driver's Side Hanger Plate (1982-87 Chevrolet/GMC C20/C30 & K20/K30)
4	30124	1	Passenger's Side Hanger Plate Support Arm
5	30120	1	Driver's Side Hanger Plate Support Arm
6	39032	1	Light Tower, Round Mounting Tube
7	61152	6	1/2"-13 x 4-1/2" Grade 8 YZ Hex Head Cap Screw
8	61026	12	1/2", 1-1/16" O.D., 17/32" I.D. YZ SAE Mil-Carb High-Strength Washer
9	61020	22	1/2"-13 Grade C Z Top Lock Nut
10	61055	8	1/2"-13 x 1-1/2" Grade 8 YZ Hex Head Cap Screw
11	61153	4	7/16"-14 x 4-1/2" Grade 8 YZ Hex Head Cap Screw
12	61162	4	7/16", 59/64" O.D., 15/32" I.D. YZ SAE Mil-Carb High-Strength Washer
13	61154	4	7/16"-14 Grade C Z Top Lock Nut
14	61018	6	1/2"-13 x 2" Grade 8 YZ Hex Head Cap Screw
15	61057	2	1/2"-13 x 1-1/4" Grade 8 YZ Hex Head Cap Screw
<b>N/A</b>	<b>61156</b>	<b>1</b>	<b>1982-1987 Chevrolet/GMC C20/C30 &amp; K20/K30 Undercarriage Hardware Kit - Kit Includes: Nos. 7 - 15</b>

Note: The reference numbers listed identify parts shown in the illustration above. These numbers are specific to this illustration only and do not correspond with other diagrams issued. Always review the part number given for proper component identification.

# 1988-1998 CHEVROLET/GMC 2500 & 3500 SERIES, 1999-2000 CHEV/GMC 3500 SERIES UNDERCARRIAGE

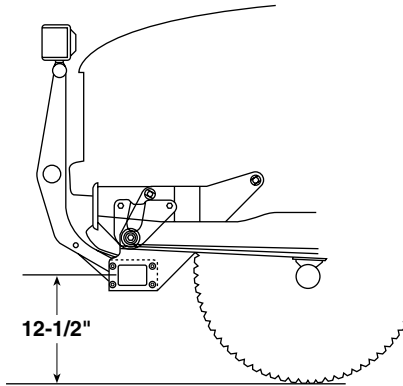

The recommended push beam height for all undercarriage assemblies is 12-1/2" from the center of the push beam to level ground. DO NOT exceed 14" in height for any undercarriage.



**WARNING:** Most new trucks are equipped with driver and passenger's side air bags. DO NOT remove, disable, or reposition any sensory equipment related to the safe operation of the air bags.

ALWAYS follow the vehicle manufacturer's recommendations for installing snowplowing equipment.

Failure to comply with the above warning may result in serious injury or death.



**CAUTION:** If your vehicle is equipped with oversize tires, they may come into contact with the undercarriage hanger plates when turning the vehicle.

The problem may be resolved by setting the steering stops on the vehicle. If this does not correct the problem, the original tires will need to be installed on the vehicle.

1. Begin the assembly by removing the three metric bolts and washers that attach to the CORE SUPPORT MOUNT BRACKET and TRUCK FRAME RAIL on both sides of the truck. Discard all bolts and washers.
2. Position the DRIVER'S SIDE HANGER PLATE on the outside of the truck frame rail and core support mount bracket. Secure three M14 x 2.0 x 45 (8.8 Gr.) bolts with M14 washers through each of the holes. *Note: Each hole contains a welded nut on the inside of the truck frame rail eliminating the need for new hardware. Repeat the same installation for the PASSENGER'S SIDE HANGER PLATE.*
3. Mount the PUSH BEAM to each hanger plate using four 1/2"-13 x 1-1/2" bolts and top lock nuts. *Note: The proper height for the push beam is approximately 12-1/2" from the ground to the center of the beam.*
4. Position the PUSH BEAM SUPPORT ARMS on the inside of the mounting brackets at the rear of the push beam. Secure each arm with two 1/2"- 13 x 1-3/4" bolts and 1/2" top lock nuts.
5. Secure the push beam support arms to the TRUCK FRAME CROSS-MEMBER with two 5/8"-11 x 2" bolts with washers and 5/8" nuts. *Note: The washers and nuts need to be positioned inside of the truck frame crossmember. Access to the interior of the crossmember can be found either behind the crossmember (older models) or to either side of it (newer models) depending on the date of manufacture.*
6. Once all of the undercarriage plates have been positioned and the proper push beam height is set, proceed to tighten all top lock nuts. Reference the chart on page 4 for maximum bolt torque.
7. Position the LIGHT TOWER into the accepting pockets on the push beam and tighten using two 1/2"-13 x 1-1/4" bolts with washers. Secure each bolt with a 1/2" top locking nut. Mount each PLOW HEADLIGHT to the light tower with the hardware kit provided.

Complete the assembly by plugging the connectors from the lights into the connectors on the vehicle wire harness.

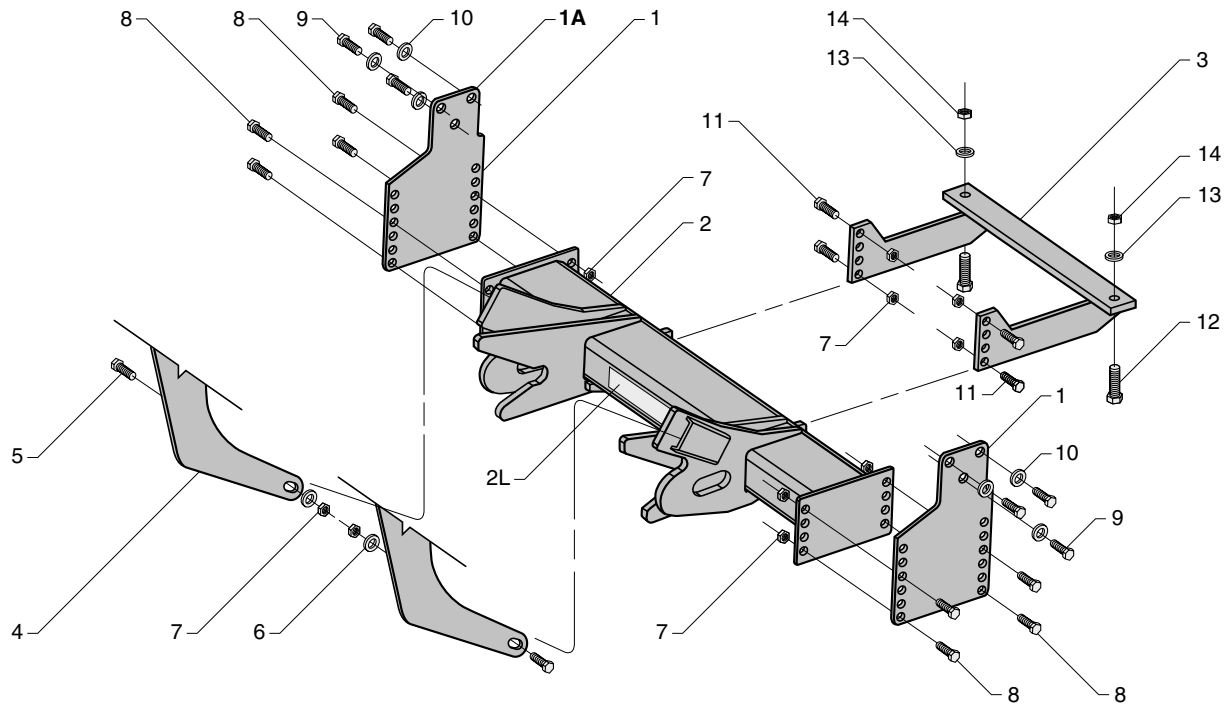

**1988-98 CHEV/GMC 2500 & 3500 SERIES, 1999-2000 3500 SERIES UNDERCARRIAGE PARTS LIST**

Ref. No.	Part No.	Qty.	Part Description
<b>1A</b>	<b>30043</b>	<b>1</b>	<b>1988-1998 Chevrolet/GMC 2500 &amp; 3500 Series, 1999-2000 Chev/GMC 3500 Series Undercarriage Assembly (Nos. 1 - 14)</b>
1	30032	2	Passenger's & Driver's Side Hanger Plate (1988-98 Chev/GMC 1500, 2500 & 3500, 1999-2000 Chev/GMC 3500)
2	30033	1	34-3/32" Push Beam (1988-98 Chev/GMC 2500 & 3500, 1999-2000 Chev/GMC 3500)
2L	61085	1	2-1/8" x 13-1/8" Push Beam Decal
3	30038	1	Push Beam Support Arm (1988-98 Chev/GMC 1500, 2500 & 3500, 1999-2000 Chev/GMC 3500)
4	39032	1	Light Tower, Round Mounting Tube
5	61057	2	1/2"-13 x 1-1/4" Grade 8 YZ Hex Head Cap Screw
6	61026	2	1/2", 1-1/16" O.D., 17/32" I.D. YZ SAE Mil-Carb High-Strength Washer
7	61020	14	1/2"-13 Grade C Z Top Lock Nut
8	61055	8	1/2"-13 x 1-1/2" Grade 8 YZ Hex Head Cap Screw
9	61072	6	M14-2.0 x 45 Grade 8.8 Z Hex Head Cap Screw
10	61074	6	M14 I.D., 28 O.D. Z Flat Washer
11	61150	4	1/2"-13 x 1-3/4" Grade 8 YZ Hex Head Cap Screw
12	61071	2	5/8"-11 x 2" Grade 8 YZ Hex Cap Screw
13	61064	2	5/8", 1-5/16" O.D., 21/32" I.D., YZ SAE Mil-Carb High-Strength Washer
14	61063	2	5/8"-11 Grade C Z Top Lock Nut
<b>N/A</b>	<b>61077</b>	<b>1</b>	<b>1988-1998 Chevrolet/GMC 1500, 2500 &amp; 3500 Series, 1999-2000 Chevrolet/GMC 3500 Series Undercarriage Hardware Kit - Kit Includes: Nos. 5 - 14</b>

Note: The reference numbers listed identify parts shown in the illustration above. These numbers are specific to this illustration only and do not correspond with other diagrams in the manual. Always review the part number given for proper component identification.

# 1988-2000 CHEV/GMC 1 TON HEAVY-DUTY 2WD

## UNDERCARRIAGE

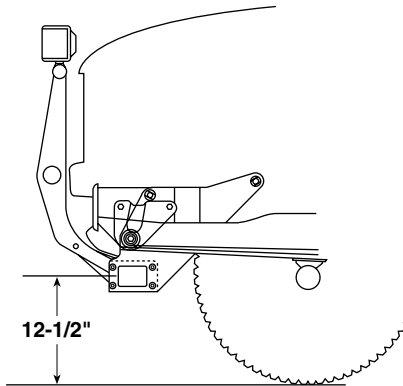

The recommended push beam height for all undercarriage assemblies is 12-1/2" from the center of the push beam to level ground. DO NOT exceed 14" in height for any undercarriage.



**WARNING:** Most new trucks are equipped with driver and passenger's side air bags. DO NOT remove, disable, or reposition any sensory equipment related to the safe operation of the air bags.

ALWAYS follow the vehicle manufacturer's recommendations for installing snowplowing equipment.

Failure to comply with the above warning may result in serious injury or death.



**CAUTION:** If your vehicle is equipped with oversize tires, they may come into contact with the undercarriage hanger plates when turning the vehicle.

The problem may be resolved by setting the steering stops on the vehicle. If this does not correct the problem, the original tires will need to be installed on the vehicle.

1. Begin the assembly by removing both M12-1.75 x 35 (8.8 Gr.) bolts with washers and flanged nuts from the rear mount of each bumper support bracket. Discard all hardware.
2. Next, position the DRIVER'S SIDE HANGER PLATE on the outside of the truck frame rail and into the core support mount on the frame. *Note: The cut-out in the hanger plate fits over the leaf spring clamp bolt.* Align the holes from the bumper support bracket mount to those on the hanger plate and secure using two 1/2"-13 x 1-1/2" bolts and 1/2" top lock nuts. Secure two additional 1/2"-13 x 1-1/2" bolts and nuts opposite the bumper support mount hardware.
3. Complete the hanger plate installation by installing two 1/2"-13 x 1-1/2" bolts with welded tabs through the middle mount holes. Attach a thin gauge wire to each screw and feed the wire through the opening in the frame at the spring shackle bolt. Pull the wire and hex cap screw through the bottom mount hole in the frame and hanger plate. Secure the cap screw with a 1/2" top lock nut. Repeat the same procedure for the top mount hole.
4. Repeat steps #2 & #3 to install the PASSENGER'S SIDE HANGER PLATE.
5. Mount the PUSH BEAM to the front hanger plate mount holes using four 1/2"-13 x 1-1/2" bolts and top lock nuts. *Note: The proper height for the push beam is approximately 12-1/2" from the ground to the center of the push beam.*
6. Align the hole in the DRIVER'S SIDE PUSH BEAM SUPPORT ARM to the mount hole on the frame in front of the vehicle shock mount. Secure the support arm by "snaking" a 1/2"-13 x 1-1/2" bolt with welded tab through the opening in the frame at the spring shackle bolt. Pull the wire and bolt through the mount hole in the frame and support arm. Secure the bolt with a 1/2" top lock nut. Next, align the holes in the support arm to the rear mount holes on the hanger plate and push beam. Secure the plates using two 1/2"-13 x 2-1/4" bolts and 1/2" top lock nuts. Position a third bolt (1/2"-13 x 1-1/2") through the bottom mount hole in the hanger plate and push beam and secure with one 1/2" top lock nut.
7. Repeat step #6 to install the PASSENGER'S SIDE PUSH BEAM SUPPORT ARM.
8. Once all of the undercarriage plates have been positioned and the proper push beam height is set, proceed to tighten all top lock nuts. Reference the chart on page 4 for maximum bolt torque.
9. Position the LIGHT TOWER into the accepting pockets on the push beam and tighten using two 1/2"-13 x 1-1/4" Grade 8 YZ hex cap screws with washers. Secure each bolt with a 1/2" top locking nut. Mount each PLOW HEADLIGHT to the light tower with the hardware kit provided.

Complete the assembly by plugging the connectors from the lights into the connectors on the vehicle wire harness.



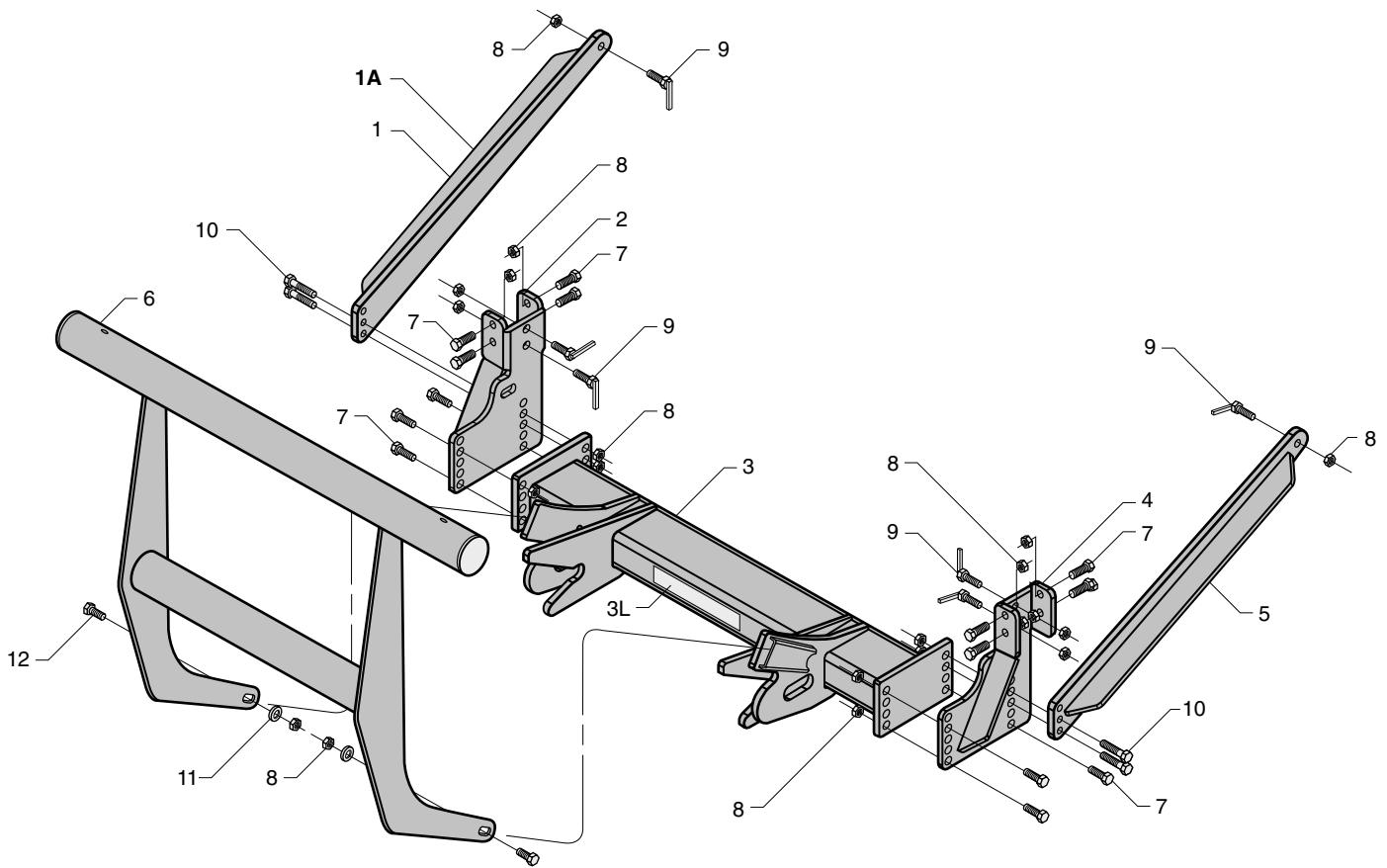

**1988-2000 CHEVROLET/GMC 1 TON HD 2WD UNDERCARRIAGE PARTS LIST**

Ref. No.	Part No.	Qty.	Part Description
<b>1A</b>	<b>30071</b>	<b>1</b>	<b>1988 - 2000 Chevrolet/GMC 1 Ton Heavy-Duty 2WD Undercarriage Assembly (Nos. 1 - 12)</b>
1	30063	1	Passenger's Side Push Beam Support Arm (1988-2000 Chev/GMC 1 Ton HD 2WD)
2	30064	1	Passenger's Side Hanger Plate (1988-2000 Chev/GMC 1 Ton HD 2WD)
3	30070	1	37" Push Beam (1988-2000 Chev/GMC 1 Ton HD 2WD)
3L	61085	1	2-1/8" x 13-1/8" Push Beam Decal
4	30065	1	Driver's Side Hanger Plate (1988-2000 Chev/GMC 1 Ton HD 2WD)
5	30067	1	Driver's Side Push Beam Support Arm (1988-2000 Chev/GMC 1 Ton HD 2WD)
6	39032	1	Light Tower, Round Mounting Tube
7	61055	14	1/2"-13 x 1-1/2" Grade 8 YZ Hex Head Cap Screw
8	61020	26	1/2"-13 Grade C Z Top Lock Nut
9	61151	6	1/2"-13 x 1-1/2" Grade 8 YZ Hex Head Cap Screw with Welded Tab
10	61054	4	1/2"-13 x 2-1/4" Grade 8 YZ Hex Head Cap Screw
11	61026	8	1/2", 1-1/16" O.D., 17/32" I.D. YZ SAE Mil-Carb High-Strength Washer
12	61057	2	1/2"-13 x 1-1/4" Grade 8 YZ Hex Head Cap Screw
<b>N/A</b>	<b>61160</b>	<b>1</b>	<b>1988 - 2000 Chevrolet/GMC 1 Ton Heavy-Duty 2WD Undercarriage Hardware Kit - Kit Includes: Nos. 7 - 12</b>

*Note: The reference numbers listed identify parts shown in the illustration above. These numbers are specific to this illustration only and do not correspond with other diagrams issued. Always review the part number given for proper component identification.*

# 1999-2002 CHEVROLET/GMC 2500 SERIES UNDERCARRIAGE

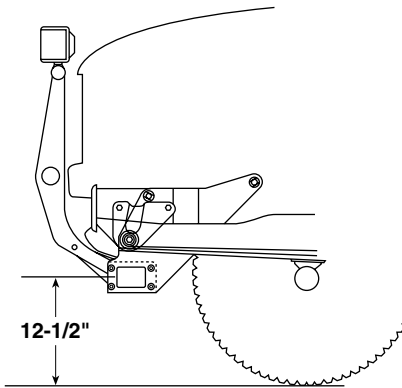

The recommended push beam height for all undercarriage assemblies is 12-1/2" from the center of the push beam to level ground. DO NOT exceed 14" in height for any undercarriage.



**WARNING:** Most new trucks are equipped with driver and passenger's side air bags. DO NOT remove, disable, or reposition any sensory equipment related to the safe operation of the air bags.

ALWAYS follow the vehicle manufacturer's recommendations for installing snowplowing equipment.

Failure to comply with the above warning may result in serious injury or death.



**CAUTION:** If your vehicle is equipped with oversize tires, they may come into contact with the undercarriage hanger plates when turning the vehicle.

The problem may be resolved by setting the steering stops on the vehicle. If this does not correct the problem, the original tires will need to be installed on the vehicle.

1. Begin the installation by removing the PLASTIC AIRFOIL mounted to the bottom of the front bumper. *Note: The airfoil will need to be permanently removed or notched to accommodate the undercarriage assembly.*
2. Remove and discard the three bolts that secure each tow hook to the truck frame. The tow hooks should remain in the same position.
3. Align the UNDERCARRIAGE MOUNTING POCKETS (at each end of the PUSH BEAM) with the tow hook mounting brackets on the vehicle. *Note: Use a hydraulic floor jack to help facilitate the installation procedure.*
4. Install two M12 x 1.75 x 45 (8.8 Gr.) bolts with M12 washers to the SIDE TOW HOOK MOUNT for each end of the assembly. *Note: Loosely attach all nuts until the remaining hardware is in position.*
5. Proceed to install one M12 x 1.75 x 40 (8.8 Gr.) bolt with an M12 washer through the TRUCK FRAME and REAR TOW HOOK MOUNT for each side of the push beam. Both bolts will tighten into the existing tow hook.
6. Install the the two 5/8"-11 x 2-1/4" bolts and 5/8" washers through the REAR SUPPORT ARMS and TRUCK FRAME CROSSMEMBER. Secure each bolt with a 5/8"-11 top lock nut.
7. Once the undercarriage is positioned with the appropriate hardware, tighten all top lock nuts. Reference the chart on page 4 for maximum bolt torque.
8. Position the LIGHT TOWER into the accepting pockets on the push beam and tighten using two 1/2"-13 x 1-1/4" bolts with washers. Secure each bolt with a 1/2" top lock nut. Mount each PLOW HEADLIGHT to the light tower with the hardware kit provided.

Complete the assembly by plugging the connectors from the lights into the connectors on the vehicle wire harness.

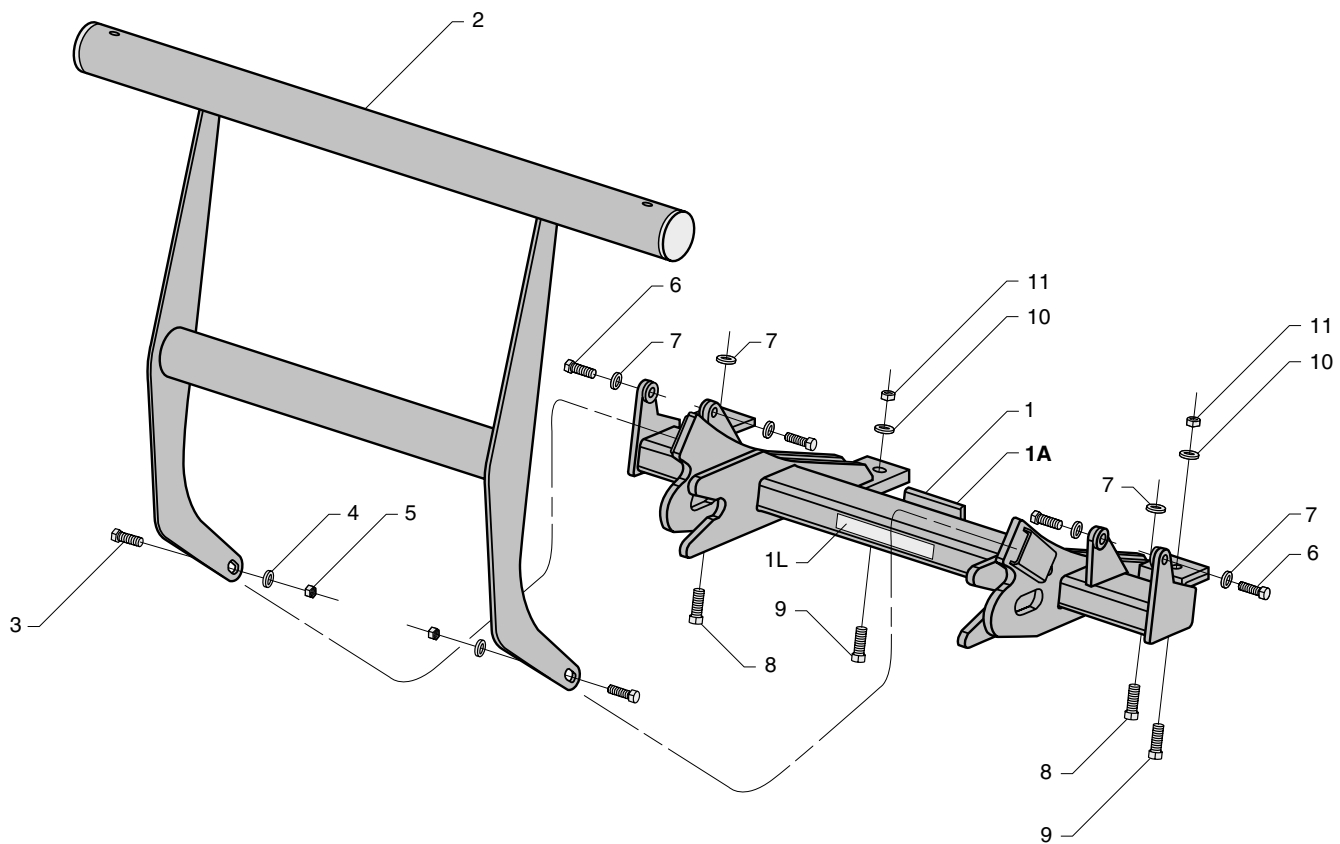

### 1999-2002 CHEVROLET/GMC 2500 SERIES UNDERCARRIAGE PARTS LIST

Ref. No.	Part No.	Qty.	Part Description
<b>1A</b>	<b>30042</b>	<b>1</b>	<b>1999-2002 Chevrolet / GMC 2500 Series Undercarriage Assembly (Nos. 1 - 11)</b>
1	30037	1	37" Push Beam (1999-2002 Chev/GMC 2500 Series)
1L	61128	1	1-1/2" x 9" Push Beam Decal
2	39032	1	Light Tower, Round Mounting Tube
3	61057	2	1/2"-13 x 1-1/4" Grade 8 YZ Hex Head Cap Screw
4	61026	2	1/2", 1-1/16" O.D., 17/32" I.D. YZ SAE Mil-Carb High-Strength Washer
5	61020	2	1/2"-13 Grade C Z Top Lock Nut
6	61068	4	M12-1.75 x 45 Grade 8.8 Z Hex Head Cap Screw
7	61070	6	M12 I.D., 24 O.D. Z Flat Washer
8	61069	2	M12-1.75 x 40 Grade 8.8 Z Hex Head Cap Screw
9	61067	2	5/8"-11 x 2-1/4" Grade 8 YZ Hex Cap Screw
10	61064	2	5/8", 1-5/16" O.D., 21/32" I.D., YZ SAE Mil-Carb High-Strength Washer
11	61063	2	5/8"-11 Grade C Z Top Lock Nut
<b>N/A</b>	<b>61076</b>	<b>1</b>	<b>1999-2002 Chevrolet / GMC 2500 Series Undercarriage Hardware Kit - Kit Includes: Nos. 3 - 11</b>

Note: The reference numbers listed identify parts shown in the illustration above. These numbers are specific to this illustration only and do not correspond with other diagrams in the manual. Always review the part number given for proper component identification.

# 1979-1993 DODGE 2500 & 3500 SERIES UNDERCARRIAGE

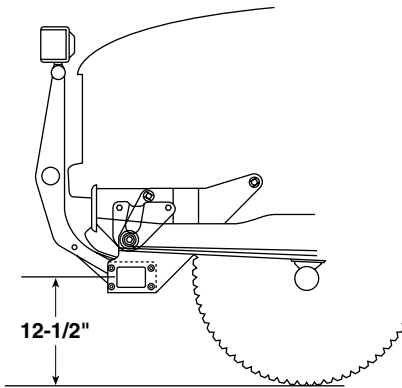

The recommended push beam height for all undercarriage assemblies is 12-1/2" from the center of the push beam to level ground. DO NOT exceed 14" in height for any undercarriage.



**WARNING:** Most new trucks are equipped with driver and passenger's side air bags. DO NOT remove, disable, or reposition any sensory equipment related to the safe operation of the air bags.

ALWAYS follow the vehicle manufacturer's recommendations for installing snowplowing equipment.

Failure to comply with the above warning may result in serious injury or death.



**CAUTION:** If your vehicle is equipped with oversize tires, they may come into contact with the undercarriage hanger plates when turning the vehicle.

The problem may be resolved by setting the steering stops on the vehicle. If this does not correct the problem, the original tires will need to be installed on the vehicle.

1. Begin the assembly by mounting the HANGER PLATE WELDMENT to the front crossmember. *Note: Depending on the model of your vehicle, the hole locations in the crossmember may be different. Review the diagram to the right for proper bushing and/or spacer mount positions.* Once you have determined the mount locations for the hanger plate, insert the STEPPED BUSHINGS and SPACERS (if needed) into position. Secure the hanger plate to the crossmember using four 5/8"-11 x 2" Grade 8 YZ hex cap screws with washers and top lock nuts.
2. Mount the PUSH BEAM to the front hanger plate mount holes using four 1/2"-13 x 1-1/2" bolts and top lock nuts. *Note: The proper height for the push beam is approximately 12-1/2" from the ground to the center of the push beam.*
3. Align the hole in the DRIVER'S SIDE PUSH BEAM SUPPORT ARM to the mount hole on the frame located behind the steering box. *Note: The support arm mounts on the inside of the truck frame rail and leaf spring.* Secure the arm to the frame with one 5/8"-11 x 4" bolt, washer and top lock nut. Complete the support arm installation by aligning the holes in the arm to the rear mount holes on the inside of the hanger plate and push beam. Secure the arm with two 1/2"-13 x 1-3/4" bolts and top lock nuts.
4. Next, position the PASSENGER'S SIDE PUSH BEAM SUPPORT ARM on the outside of the truck frame rail and inside of the leaf spring. Align the hole in the support arm with the mount hole on the frame located approximately 14" back from the core support mount. Secure the arm to the frame with one 5/8"-11 x 1-3/4" bolt, washer and top lock nut. Complete the mount by fastening the arm to the rear mount holes on the inside of the hanger plate with two 1/2"-13 x 1-3/4" bolts and top lock nuts.
5. Once all of the undercarriage plates have been positioned and the proper push beam height is set, proceed to tighten all top lock nuts. Reference the chart on page 4 for maximum bolt torque.
6. Position the LIGHT TOWER into the accepting pockets on the push beam and tighten using two 1/2"-13 x 1-1/4" Grade 8 YZ hex cap screws with washers. Secure each bolt with a 1/2" top lock nut. Mount each PLOW HEADLIGHT to the light tower with hardware kit provided.

Complete the assembly by plugging the connectors from the lights into the connectors on the vehicle wire harness.

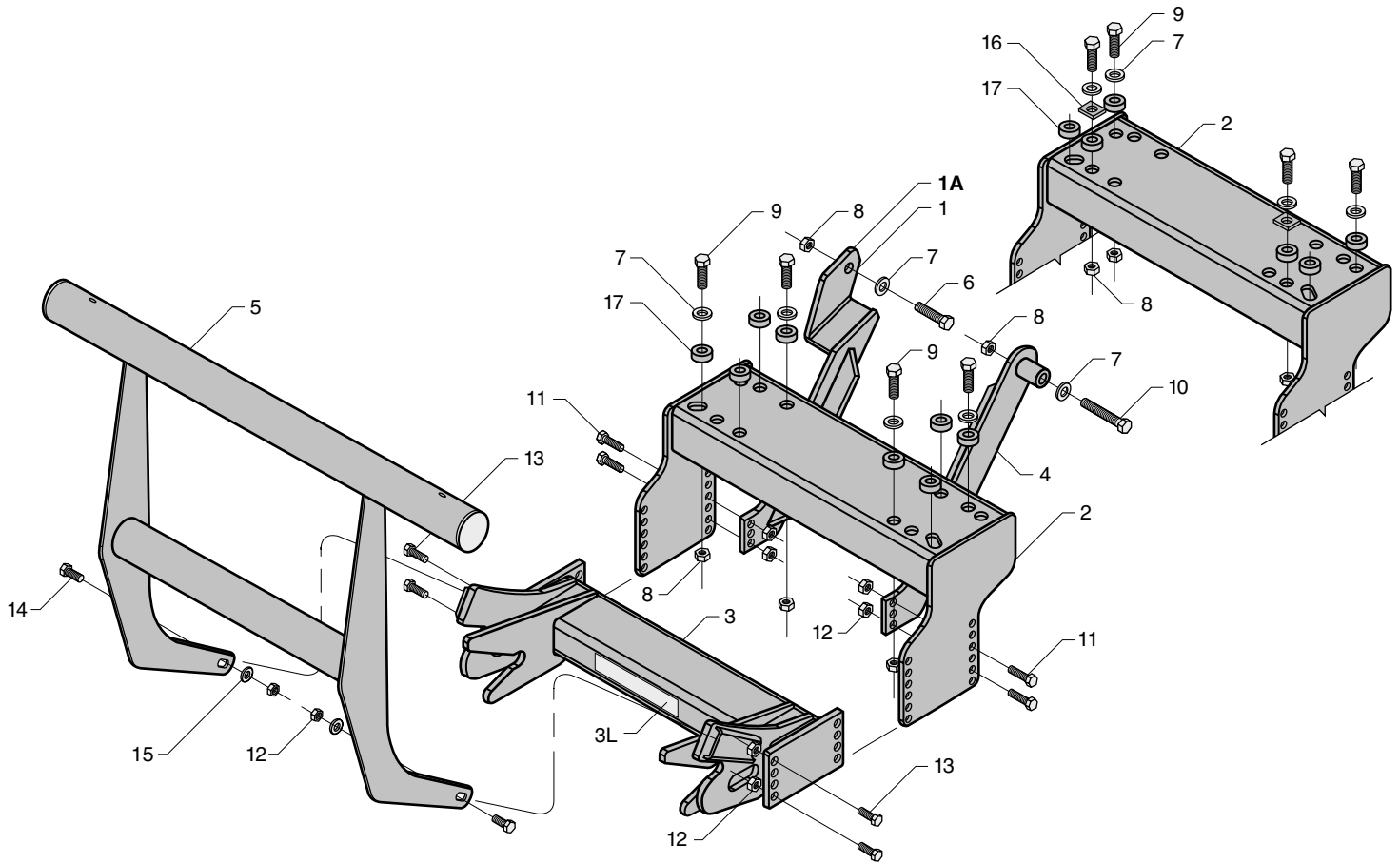

### 1979-1993 DODGE 2500 & 3500 SERIES UNDERCARRIAGE PARTS LIST

Ref. No.	Part No.	Qty.	Part Description
<b>1A</b>	<b>32034</b>	<b>1</b>	<b>1979-1993 Dodge 2500 &amp; 3500 Series Undercarriage Assembly (Nos. 1 - 17)</b>
1	32031	1	Passenger's Side Hanger Plate Support Arm (1979-93 Dodge 2500 & 3500)
2	32023	1	Passenger's Side & Driver's Side Hanger Plate Weldment (1979-93 Dodge 2500 & 3500)
3	30053	1	26-1/4" Push Beam (1979-93 Dodge 2500 & 3500 & 1982-87 Chev/GMC)
3L	61085	1	2-1/8" x 13-1/8" Push Beam Decal
4	32032	1	Driver's Side Hanger Plate Support Arm (1979-93 Dodge 2500 & 3500)
5	39032	1	Light Tower, Round Mounting Tube
6	61060	1	5/8"-11 x 1-3/4" Grade 8 YZ Hex Head Cap Screw
7	61064	6	5/8", 1-5/16" O.D., 21/32" I.D., YZ SAE Mil-Carb High-Strength Washer
8	61063	6	5/8"-11 Grade C Z Top Lock Nut
9	61071	4	5/8"-11 x 2" Grade 8 YZ Hex Head Cap Screw
10	61155	1	5/8"-11 x 4" Grade 8 YZ Hex Head Cap Screw
11	61150	4	1/2"-13 x 1-3/4" Grade 8 YZ Hex Head Cap Screw
12	61020	10	1/2"-13 Grade C Z Top Lock Nut
13	61055	4	1/2"-13 x 1-1/2" Grade 8 YZ Hex Head Cap Screw
14	61057	2	1/2"-13 x 1-1/4" Grade 8 YZ Hex Head Cap Screw
15	61026	2	1/2", 1-1/16" O.D., 17/32" I.D. YZ SAE Mil-Carb High-Strength Washer
*16	32035	2	1-1/2" x 1/4" x 1-1/4" Spacer with 11/16" Dia. Hole
**17	52011	8	1-1/2" O.D., 5/8" I.D., 3/4" Stepped Bushing
N/A	32036	1	1979-93 Dodge Bushing & Spacer Kit - Kit Includes: No. 16 - 17
<b>N/A</b>	<b>61158</b>	<b>1</b>	<b>1979-93 Dodge 2500 &amp; 3500 Series Undercarriage Hardware Kit - Kit Includes: Nos. 6 - 17</b>

\* Both spacers are used on the front, inside stepped bushings located on top of the hanger plate weldment. These are only needed for the Dodge (1 ton) undercarriage.

\*\* Depending on the vehicle, the quantity and location of the stepped bushings to be used can change. The (3/4 ton) requires 8 stepped bushings and the (1 ton) has 6. Refer to the diagram above for proper bushing orientation.

Note: The reference numbers listed identify parts shown in the illustration above. These numbers are specific to this illustration only and do not correspond with other diagrams issued. Always review the part number given for proper component identification.

# 1994-2001 DODGE 2500 & 3500 SERIES UNDERCARRIAGE

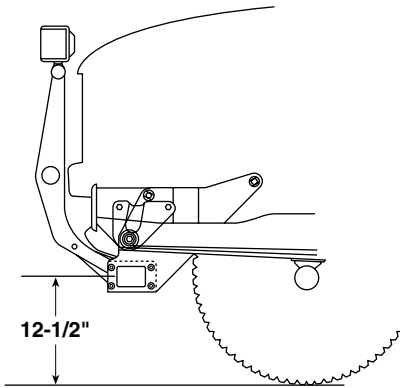

The recommended push beam height for all undercarriage assemblies is 12-1/2" from the center of the push beam to level ground. DO NOT exceed 14" in height for any undercarriage.



**WARNING:** Most new trucks are equipped with driver and passenger's side air bags. DO NOT remove, disable, or reposition any sensory equipment related to the safe operation of the air bags.

ALWAYS follow the vehicle manufacturer's recommendations for installing snowplowing equipment.

Failure to comply with the above warning may result in serious injury or death.



**CAUTION:** If your vehicle is equipped with oversize tires, they may come into contact with the undercarriage hanger plates when turning the vehicle.

The problem may be resolved by setting the steering stops on the vehicle. If this does not correct the problem, the original tires will need to be installed on the vehicle.

1. Begin the undercarriage assembly by removing the metric bolts that attach the bumper to the TRUCK FRAME RAIL and both bolts from the BUMPER SUPPORT ARMS.
2. Proceed to install each HANGER PLATE to the outside of the truck frame rail using three 1/2"-13 x 1-1/2" bolts with 1/2" washers and top lock nuts.
3. Attach the bumper support arms to the rear hanger plate mount using one M12-1.75 x 45 bolt with M12 washers and top lock nuts.
4. Install the PASSENGER'S SIDE PUSH BEAM SUPPORT ARM to the truck frame rail in front of the engine crossmember (bottom hole). Secure with one 5/8"-11 x 4-1/2" bolt, washer and a top lock nut.
5. Install the DRIVER'S SIDE PUSH BEAM SUPPORT ARM to the truck frame rail and crossmember located under the steering shaft. Mount one 1/2"-13 x 5" bolt and washer from the underside of the crossmember and secure with one top lock nut.
6. Proceed to install one 1/2"-13 x 1-1/2" bolt with welded tab on the driver side support arm to the truck frame rail. "Snake" the welded bolt through the access hole behind the support arm on the truck frame rail using a stiff wire. Position the bolt through the hole with the welded tab on the interior of the rail. *Note: The welded tab will prohibit the bolt from turning while tightening the 1/2" nut and washer.*
7. Attach the PUSH BEAM to each hanger plate using eight 1/2"-13 x 1-1/2" bolts. Attach both push beam support arms to the brackets at the rear of the push beam using four 1/2"-13 x 1-1/2" bolts. Secure all bolts with 1/2" top lock nuts.
8. Once the undercarriage is positioned with the appropriate hardware, tighten all top lock nuts. Reference the chart on page 4 for maximum bolt torque.
9. Replace the bumper and bumper support arms with the original hardware.
10. Position the LIGHT TOWER into the accepting pockets on the push beam and tighten using two 1/2"-13 x 1-1/4" bolts with washers. Secure each bolt with a 1/2" top lock nut. Mount each PLOW HEADLIGHT to the light tower with the hardware kit provided.

Complete the assembly by plugging the connectors from the lights into the connectors on the vehicle wire harness.

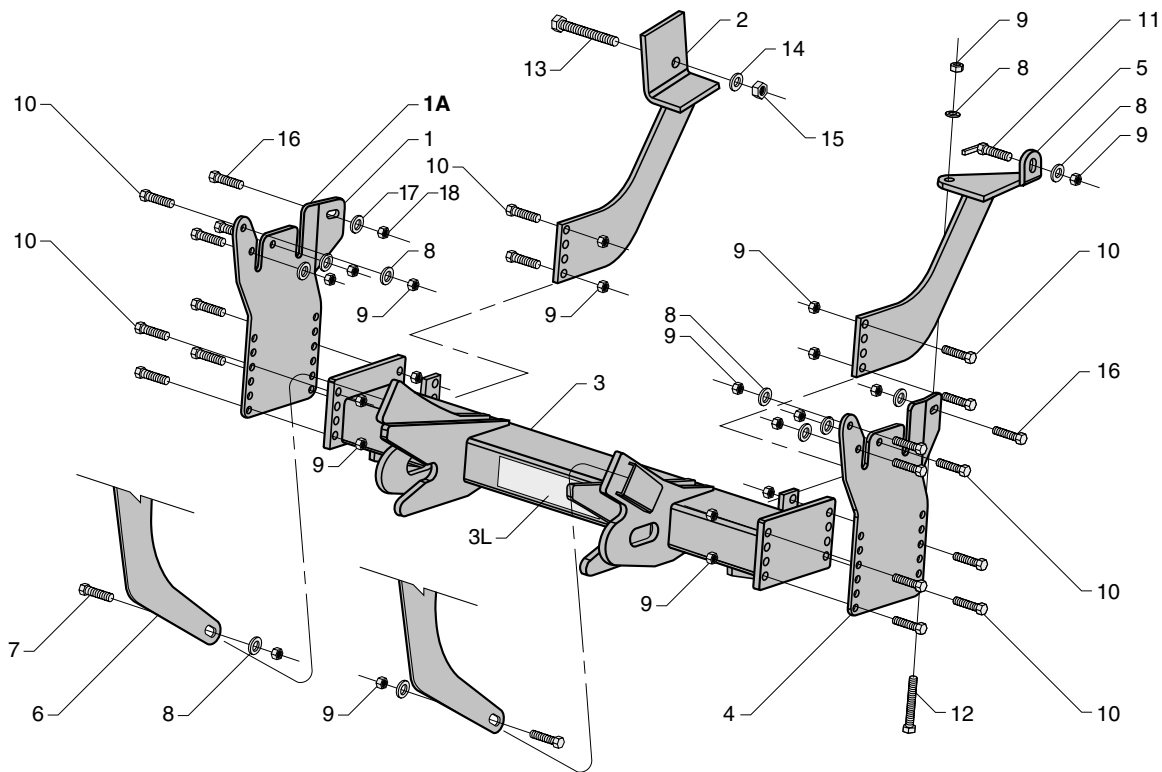

### 1994-2001 DODGE 2500 & 3500 SERIES UNDERCARRIAGE PARTS LIST

Ref. No.	Part No.	Qty.	Part Description
<b>1A</b>	<b>32013</b>	<b>1</b>	<b>1994-2001 Dodge 2500 &amp; 3500 Series Undercarriage Assembly (Nos. 1 - 18)</b>
1	32019P	1	Passenger's Side Hanger Plate (1994-2001 Dodge 2500 & 3500)
2	32014	1	Passenger's Side Push Beam Support Arm (1994-2001 Dodge 1500, 2500 & 3500)
3	32005	1	36-1/4" Push Beam (1994-2001 Dodge 2500 & 3500)
3L	61085	1	2-1/8" x 13-1/8" Push Beam Decal
4	32019D	1	Driver's Side Hanger Plate (1994-2001 Dodge 2500 & 3500)
5	32017	1	Driver's Side Push Beam Support Arm (1994-2001 Dodge 1500, 2500 & 3500)
6	39032	1	Light Tower, Round Mounting Tube
7	61057	2	1/2"-13 x 1-1/4" Grade 8 YZ Hex Head Cap Screw
8	61026	10	1/2", 1-1/16" O.D., 17/32" I.D. YZ SAE Mil-Carb High-Strength Washer
9	61020	22	1/2"-13 Grade C Z Top Lock Nut
10	61055	18	1/2"-13 x 1-1/2" Grade 8 YZ Hex Head Cap Screw
11	61151	1	1/2"-13 x 1-1/2" Grade 8 YZ Hex Head Cap Screw with Welded Tab
12	61075	1	1/2"-13 x 5" Grade 8 YZ Hex Head Cap Screw
13	61065	1	5/8"-11 x 4-1/2" Grade 8 YZ Hex Cap Screw
14	61064	1	5/8", 1-5/16" O.D., 21/32" I.D., YZ SAE Mil-Carb High-Strength Washer
15	61063	1	5/8"-11 Grade C Z Top Lock Nut
16	61068	2	M12-1.75 x 45 Grade 8.8 Z Hex Head Cap Screw
17	61070	2	M12 I.D., 24 O.D. Z Flat Washer
18	61271	2	M12-1.75 Class C Top Lock Nut
<b>N/A</b>	<b>61078</b>	<b>1</b>	<b>1994-2001 Dodge 1500, 2500 &amp; 3500 Series Hardware Kit - Kit Includes: Nos. 7 - 18</b>

Note: The reference numbers listed identify parts shown in the illustration above. These numbers are specific to this illustration only and do not correspond with other diagrams in the manual. Always review the part number given for proper component identification.

# TROUBLESHOOTING GUIDE

Prior to diagnosing your Power Plow, verify that all connectors (plow and vehicle wire harness plugs, headlight adapters, control box, fused hot lead, draw latch switch, solenoid ground wire harness, coil wire lead harness, plow headlight harnesses) are free of corrosion and are well lubricated with white lithium grease. Insuring that all connectors are in good working order will save time in determining your snowplow's service needs.

Problem	Probable Cause(s)	Suggested Remedy
Pump will not run.	Plow wire harness and vehicle wire harness may not be properly connected.	Verify the wire harness is properly connected. Review the instruction on pages 8-11.
	Ground cables to the battery, manifold or solenoid may not be properly connected.	Properly connect all cables. Clean and lubricate with white lithium grease.
Pump will not run, no power to the solenoid.	The red, power wire and brown/white, activation wire on the solenoid are not properly connected.	Properly connect both cables. Test for power by initiating any rocker switch function except the float. Note: The POWER rocker switch must be in the "ON" position to properly test any plow function. No power, diagnose plow & truck wire harness.
Pump will not run with power to the solenoid.	The red, hot wire to the pump motor is not properly connected.	Connect red wire. If problem is not resolved, the solenoid could be seized or the pump motor may be worn. Replace solenoid.
Pump will not turn off.	Pump solenoid may be damaged.	Disconnect the brown activation wire from the solenoid. If the problem is not resolved, replace the solenoid.
	Diode pack may be corroded.	Clean diode pack thoroughly and/or replace.
	Short in the control box or wire harness.	Disconnect the control box in the cab. If the solenoid turns off, there is a short in the electrical system.
Pump runs but plow functions are slow.	Fluid level in the pump reservoir is low. Fluid is leaking.	Add fluid to within 3/4" from the top of the tank. Check for leaks around the pump, manifold and cylinders.
	System pressure may be set too low.	Adjust the pressure. Remove the hex cap on top of the pump and turn the screw clockwise 1/8 turn. Proper system pressure should be set at 1800 PSI. Test functions and repeat procedure as needed.
	Voltage from the vehicle's alternator is too low.	Repair or replace vehicle alternator. Voltage must be no less than 11.8 volts.
	Pump filter may be clogged.	Remove the pump tank and thoroughly clean the filter.
A-frame latch will not move.	Draw latch is binding the A-frame latch.	Lift the draw latch to relieve binding on the A-frame latch and reposition the A-frame latch as needed.
Plow will not lift. Pump works properly.	Control station in the cab may not be properly connected.	Connect the power connector from the control to the vehicle wire harness.
	A-frame latch is in the (down) locked position.	Lift the A-frame latch into the raised position.
	Solenoid may be damaged.	Remove both S6 & S7 solenoids from the cartridge valves. Position a screwdriver inside of the solenoid and push the draw latch connect/disconnect toggle switch upward. The solenoid should be magnetically drawn to the screwdriver. Replace solenoid if there is no action.



Problem	Probable Cause(s)	Suggested Remedy
	Hydraulic lock in the manifold.	Loosen cartridge valve S5 or S8 to relieve pressure and retighten. DO NOT OVERTIGHTEN!
	Solenoid cartridge valve may be contaminated.	Remove any foreign objects that may be obstructing proper valve operation. Replace if not operating properly after cleaning.
Wing will not stay angled when plowing.	The wing pressure relief valve is set too low. NOTE: Increasing the pressure relief valve will cause damage to your plow. Do not set the pressure relief greater than 1500 PSI.	Test the wing pressure relief. Attach a T-fitting with a fluid PSI gauge to the base end of the wing cylinder. Pressure relief should not be greater than 1500 PSI. Review the illustration below to increase the pressure relief settings.
Plow will not stay angled when plowing.	The angle pressure relief valve is set too low. NOTE: Increasing the pressure relief valve will cause damage to your plow. Do not set the pressure relief greater than 3000 PSI.	Follow the guidelines indicated above; however, the PSI setting should not exceed 3000 PSI. NOTE: If the plow is floating back when angled to the right, adjust the left pressure relief valve and vice versa.
Wing will not move, pump works.	Control station, wire harness or cables may be loose or improperly connected.	Verify control station, wire harness and all cables are securely connected. Clean if necessary.
	Hydraulic lock in manifold.	Loosen cartridge valves S9 & S10 or S1 & S2 to relieve pressure and retighten. DO NOT OVERTIGHTEN!
	No power to the solenoid.	Verify solenoids S1 & S2 (passenger's side slide box retract and extend) and S9 & S10 (driver's side slide box retract and extend) are connected properly. Diagnose the wire harness. Review the plow wire schematic on page 27 and the vehicle wire schematic on pages 29-31. If power is present, review the next step.
	Solenoids are not receiving power.	Verify that the solenoids are magnetizing. Position a screwdriver inside of the solenoid. When the respective function is activated, the screwdriver is drawn to the side of the solenoid. If the solenoid is not drawn to the screwdriver, replace the solenoid. If power is present, review the next step.
	Solenoid cartridge may be contaminated or damaged. A bent cartridge will not allow the valve to move freely inside of the cartridge.	Determine a damaged cartridge valve by reversing the driver's side and passenger's side cartridge valves. Replace valve if necessary.
Plow will not angle, pump works.	Review all probable causes above.	NOTE: Verify solenoids S3 & S4 for angle functions.

Should your snowplow develop other problems not indicated in the Troubleshooting Guide, contact your local dealer for technical assistance and/or replacement parts. Technical support can also be obtained calling our Customer Service Department at 1-888-680-8600, Monday - Friday, 8AM - 5PM EST.

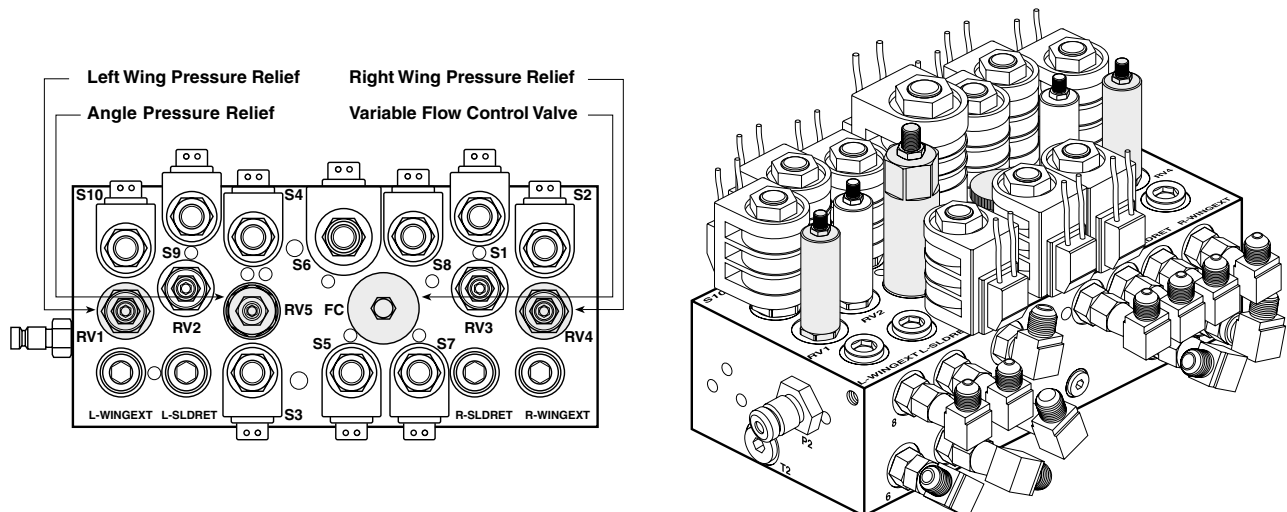



## LIMITED CONSUMER WARRANTY

This warranty covers defects in material and workmanship except as set forth below.

### WARRANTED PARTY:

This warranty applies only to the "Original Purchaser" who purchased this plow from an Authorized Blizzard Dealer, for personal, family or household use.

### TERM OF WARRANTY:

This Blizzard Power Plow is warranted for the following period:  
Parts and labor are warranted for one year from date of purchase.

### BLIZZARD CORPORATION'S WARRANTY REMEDY:

Blizzard Corporation will, at its sole discretion, repair or replace defective parts at no charge.

### CUSTOMERS RESPONSIBILITY:

To obtain warranty service, the purchaser must return the defective snowplow to any Authorized Blizzard Dealer. The purchaser must verify the original purchase date. Transportation costs to and from the dealer will be the responsibility of the purchaser.

### ITEMS NOT COVERED UNDER THIS WARRANTY:

This limited warranty does not cover the following:

1. Expendable parts such as cutting edges, plow shoes, hoses, fasteners, blade guides, paint finish, etc.
2. Any snowplow or part thereof which has been repaired or altered by anyone other than an Authorized Blizzard Dealer.
3. Any snowplow or part thereof which has been subject to neglect, misuse, accident, improper installation, maintenance, or storage. This includes, but is not limited to, corrosion of any electrical components.
4. Snowplows mounted on vehicles other than those for whom Blizzard Corporation has provided a specific undercarriage system.
5. Blizzard Corporation does not assume liability for damage to the purchaser's vehicle resulting from the attachment and use of a Blizzard Power Plow. Vehicle risk is the sole responsibility of the purchaser.

### WARRANTY LIMITATIONS:

THIS WARRANTY IS OFFERED IN LIEU OF ANY OTHER EXPRESS WARRANTY.

THE DURATION OF ALL IMPLIED WARRANTIES, INCLUDING BUT NOT LIMITED TO THE IMPLIED WARRANTIES OF MERCHANTABILITY AND FITNESS FOR A PARTICULAR PURPOSE, ARE LIMITED TO THE DURATION OF THIS WARRANTY.

BLIZZARD CORPORATION'S LIABILITY IS EXPRESSLY LIMITED TO REPAIR OR REPLACEMENT OF DEFECTIVE PARTS. BLIZZARD CORPORATION SHALL NOT BE LIABLE FOR CONSEQUENTIAL, INCIDENTAL OR CONTINGENT DAMAGES WHATSOEVER, EVEN IF DAMAGES ARE CAUSED BY THE NEGLIGENCE OR FAULT OF BLIZZARD CORPORATION.

**State Laws:** Some states do not allow exclusion of incidental or consequential damages or the limitations on how long an implied warranty lasts, so these limitations or exclusions may not apply to you. This warranty gives you specific legal rights and you may also have other rights which vary from state to state.

This warranty does not apply if you purchased your snowplow for other than personal, family, or household use. If purchased for other than personal, family or household use, refer to the Blizzard Power Plow Commercial Warranty.



95 AIRPARK BOULEVARD ■ CALUMET, MICHIGAN 49913 ■ (906) 482-5555

1029-7-99 REV 8/01



## COMMERCIAL WARRANTY

This warranty covers defects in material and workmanship except as set forth below.

### WARRANTED PARTY:

This warranty applies only to the "Original Purchaser" who purchased this plow from an Authorized Blizzard Dealer, for commercial use.

### TERM OF WARRANTY:

This Blizzard Power Plow is warranted for the following period:  
Parts and labor are warranted for one year from date of purchase.

### BLIZZARD CORPORATION'S WARRANTY REMEDY:

Blizzard Corporation will, at its sole discretion, repair or replace defective parts at no charge.

### CUSTOMERS RESPONSIBILITY:

To obtain warranty service, the purchaser must return the defective snowplow to any Authorized Blizzard Dealer within the warranty period. The purchaser must verify the original purchase date. Transportation costs to and from the Dealer will be the responsibility of the purchaser.

### ITEMS NOT COVERED UNDER THIS WARRANTY:

This warranty does not cover the following:

1. Expendable parts such as cutting edges, plow shoes, hoses, fasteners, blade guides, paint finish, etc.
2. Any snowplow or part thereof which has been repaired or altered by anyone other than an Authorized Blizzard Dealer.
3. Any snowplow or part thereof which has been subject to neglect, misuse, accident, improper installation, maintenance, or storage. This includes, but is not limited to, corrosion of any electrical components.
4. Snowplows mounted on vehicles other than those for whom Blizzard Corporation has provided a specific undercarriage system.
5. Blizzard Corporation does not assume liability for damage to the purchaser's vehicle resulting from the attachment and use of a Blizzard Power Plow. Vehicle risk is the sole responsibility of the purchaser.

### LIMITS OF BLIZZARD CORPORATION'S LIABILITIES:

BLIZZARD CORPORATION'S LIABILITY IS EXPRESSLY LIMITED TO REPAIR OR REPLACEMENT OF DEFECTIVE PARTS. BLIZZARD CORPORATION SHALL NOT BE LIABLE FOR CONSEQUENTIAL, INCIDENTAL OR CONTINGENT DAMAGES WHATSOEVER, EVEN IF DAMAGES ARE CAUSED BY THE NEGLIGENCE OR FAULT OF BLIZZARD CORPORATION.

THE FOREGOING WARRANTIES ARE EXCLUSIVE AND IN LIEU OF ALL OTHER EXPRESSED AND IMPLIED WARRANTIES INCLUDING, BUT NOT LIMITED TO, THE IMPLIED WARRANTIES OF MERCHANTABILITY AND FITNESS FOR A PARTICULAR PURPOSE.

This warranty does not apply if you purchased your snowplow for personal, family, or household use. In this case, refer to the Blizzard Power Plow Limited Consumer Warranty.



95 AIRPARK BOULEVARD ■ CALUMET, MICHIGAN 49913 ■ [906] 482-5555

1030-7-99 REV 8/01



95 Airpark Boulevard  
Calumet, MI 49913  
[888] 680-8600  
[906] 482-5555  
[906] 482-5445 Fax  
[www.blizzardplows.com](http://www.blizzardplows.com)

Blizzard, Power Plow, WidePass, BucketBlade and Seat Cinch are trademarks of Blizzard Corporation. Blizzard is registered in the United States Patent and Trademark Office. The Blizzard Power Plow snowplow is protected by U.S. patents 5,638,618; 5,899,007 & 6,276,076. Other patents pending. Copyright © 2001 Blizzard Corporation. All rights reserved. Made and printed in the USA. 1226-9-01