



95330
Hopper and Drive Components
Model 500
Low-Profile Tailgate Spreader
Parts List

This Parts List is for WESTERN® Model 500 Low-Profile Tailgate Spreaders with serial numbers beginning with 030101 and higher.

MODEL 500 LOW-PROFILE TAILGATE SPREADER

HOPPER COMPONENTS

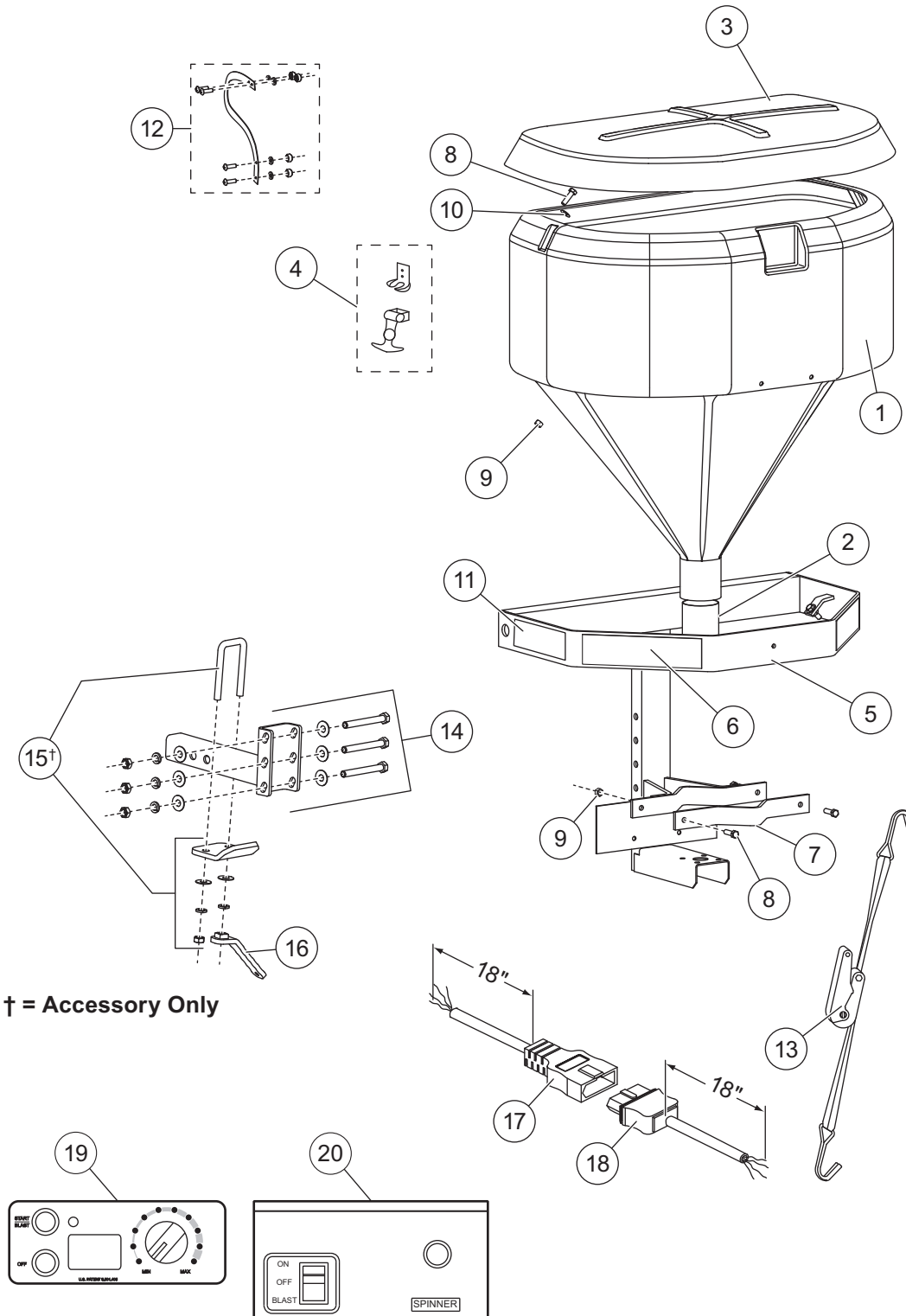

Controls sold separately.

MODEL 500 LOW-PROFILE TAILGATE SPREADER

Hopper Components							
Item	Part	Qty	Description	Item	Part	Qty	Description
1	95327	1	Hopper Assembly, Red w/Throat Liner	7	95313	1	Tub Brace
2	P2003	1	Throat Liner	8	98378	4	3/8-16 x 1-1/4 Hex Cap Screw SS
3	95329	1	Hopper Lid (No Hardware)	9	91333	4	3/8-16 Hex Locknut
ns	95456	1	Lid w/Latch Kit (Incl. 95329 & P3045)	10	M2017*	2	3/8" Flat Washer
4	P3045	1	Lid Latch Kit (Incl. straps, hooks and all hardware)	11	94426	2	Label, Information – Receiver Hitch
5	95310	1	Main Frame	12	94534	2	Nylon Strap Kit
6	68584	2	Label Information (Warning)	ns	95336	1	Parts Kit, Model 500 Spreader
				ns	76068	1	Label, "UP" Tailgate Spreader Hitch
95336 Parts Kit, Model 500 Spreader							
13	68789	2	Ratchet Strap Assembly	15 [†]	48852	1	Receiver Clamp Kit
14	95318-1	1	Hitch Insert w/Hardware				
Item 14	95318-1 Hitch Insert w/Hardware						
	1		Hitch Insert		3		1/2" Lock Washer Spring SS
	3		1/2-13 x 4-1/2 Hex Cap Screw G5		3		1/2-13 Hex Nut SS
	6		1/2" Flat Washer Wide SS				
Item 15 [†]	48852 Receiver Clamp Kit						
	1		Clamp Plate		2		1/2" Lock Washer Spring SS
	1		1/2-13 U-Bolt SS		1		1/2-13 Hex Nut SS
	2		1/2" Flat Washer Wide SS	16	96263	1	1/2-13 Nut Handle
ns = not shown		SS = Stainless Steel		† = Accessory Only		G = Grade	
* available as part of service parts kit only (5 pieces per package)							

Hopper Electrical Components							
Item	Part	Qty	Description	Item	Part	Qty	Description
ns	63634	1	Harness, Spreader – 4 Pin	ns	63633	1	Harness, Vehicle – 4 Pin
17	63693	1	Harness, Spreader End Kit (use w/3- or 4-Pin Connectors)	18	63692	1	Harness, Vehicle End Kit (use w/3- or 4-Pin Connectors)
ns = not shown							

Hopper Controls – Sold Separately							
Item	Part	Qty	Description	Item	Part	Qty	Description
19	28866	1	Variable Speed (PWM) Control	20	67070	1	ON/OFF Control

MODEL 500 LOW-PROFILE TAILGATE SPREADER

DRIVE COMPONENTS

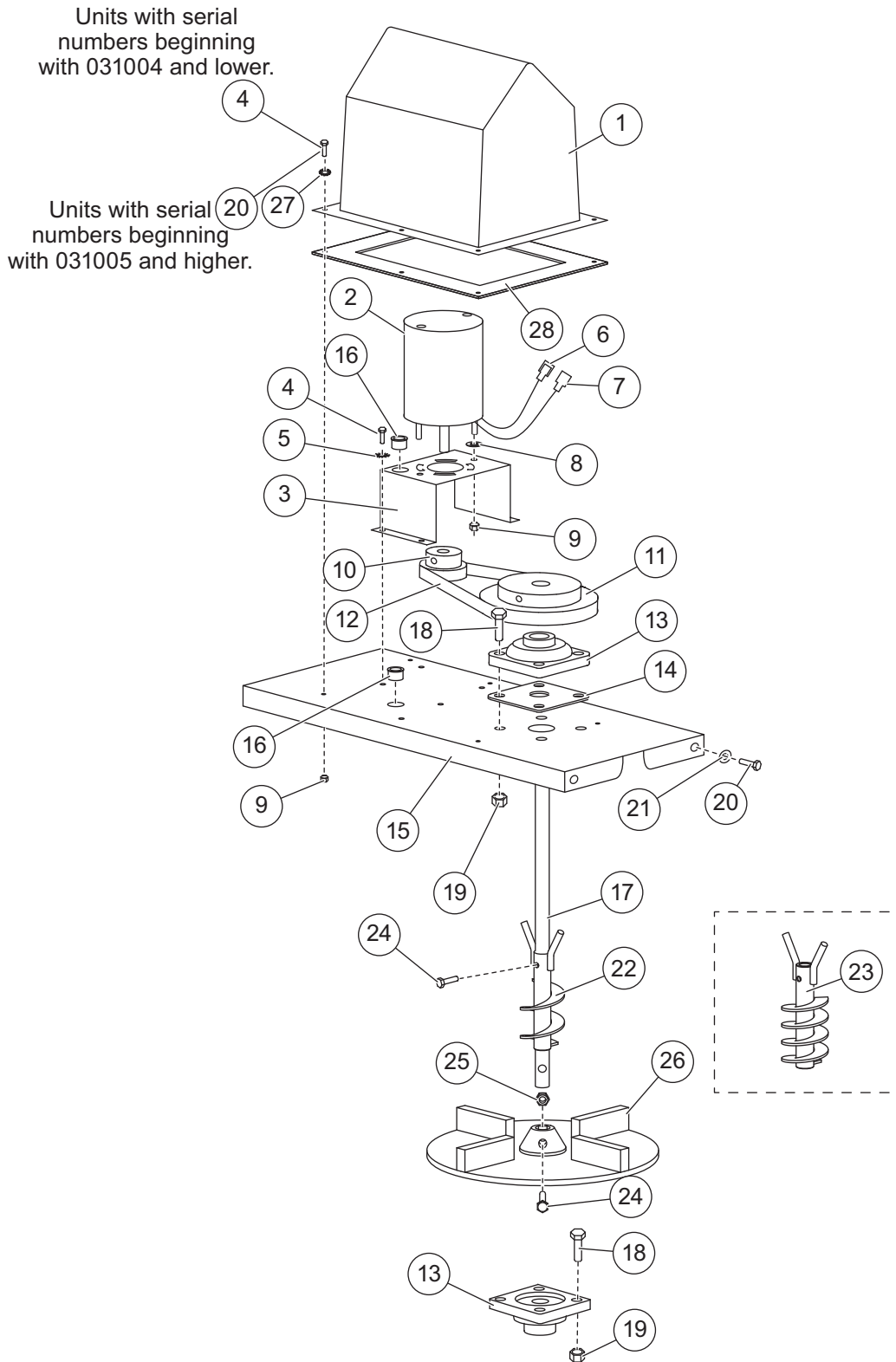

MODEL 500 LOW-PROFILE TAILGATE SPREADER

Drive Components							
Item	Part	Qty	Description	Item	Part	Qty	Description
1	P2121Y	1	Motor Cap Assembly	16	M1362	2	Grommet
2	P3035	1	Motor 12V DC 1/3 HP	17	P3046	1	Drive Shaft
3	P2010	1	Motor Pedestal	18	98378	8	3/8-16 x 1-1/4 Hex Cap Screw SS
4	68512	10	#10-32 x 5/8 Machine Screw SS	19	91333	8	3/8-16 Hex Locknut GB
5	68513	4	#10 External Lock Washer SS	20	90381	10	1/4-20 x 3/4 Hex Cap Screw SS
6	M1458*	1	1/4" Insulated Blade Terminal	21	91013	4	1/4" Flat Washer Narrow SS
7	M1459*	1	1/4" Fully Insulated Receptacle	22	29995	1	Auger, 3-Flight (Standard – For Coarse Material)
8	M2052	2	M5 Flat Washer	23	P2028	1	Auger, 5-Flight (Optional – For Fine Material)
9	68511	8	#10-32 Hex Locknut GB SS	24	94496	2	1/4-20 x 2 Hex Cap Screw SS
10	P2100	1	Pulley, Drivegear – 12T	25	67076	2	1/4-20 Hex Locknut GB SS
11	P2101	1	Gear Belt Pulley 40T	26	94510	1	Spinner Kit (Polyurethane)
12	M1355	1	Gear Belt	27	67083	6	1/4" External Lock Washer SS
13	68662	2	5/8" 4-Bolt Flange Bearing	28	95333	1	Gasket, Low Pro Motor Cap
14	P2095	1	Neoprene Gasket				
15	68807	1	Motor Base Plate, Service Part				
G = Grade				SS = Stainless Steel			
* available as part of service parts kit only (5 pieces per package)							

MODEL 500 LOW-PROFILE TAILGATE SPREADER

Copyright © 2011 Douglas Dynamics, L.L.C. All rights reserved. This material may not be reproduced or copied, in whole or in part, in any printed, mechanical, electronic, film or other distribution and storage media, without the written consent of Western Products. Authorization to photocopy items for internal or personal use by Western Products outlets or spreader owner is granted.

Western Products reserves the right under its product improvement policy to change construction or design details and furnish equipment when so altered without reference to illustrations or specifications used. Western Products or the vehicle manufacturer may require or recommend optional equipment for spreaders. Do not exceed vehicle ratings with a spreader. Western Products offers a limited warranty for all spreaders and accessories. See separately printed page for this important information. The following is a registered (®) trademark of Douglas Dynamics, L.L.C.: WESTERN®.

Printed in U.S.A.
